



# Kent Academic Repository

**Wang, Lijuan, Liu, Jinyu, Yan, Yong, Wang, Xue and Wang, Tao (2017) *Mass flow measurement of two-phase carbon dioxide using Coriolis flowmeters*. In: Instrumentation and Measurement Technology Conference (I2MTC), 2017 IEEE International. Proceedings of IEEE International Instrumentation and Measurement Technology Conference (I2MTC 2017). . ISBN 978-1-5090-3597-7. E-ISBN 978-1-5090-3596-0.**

## Downloaded from

<https://kar.kent.ac.uk/61896/> The University of Kent's Academic Repository KAR

## The version of record is available from

<https://doi.org/10.1109/I2MTC.2017.7969891>

## This document version

Author's Accepted Manuscript

## DOI for this version

## Licence for this version

UNSPECIFIED

## Additional information

## Versions of research works

### Versions of Record

If this version is the version of record, it is the same as the published version available on the publisher's web site. Cite as the published version.

### Author Accepted Manuscripts

If this document is identified as the Author Accepted Manuscript it is the version after peer review but before type setting, copy editing or publisher branding. Cite as Surname, Initial. (Year) 'Title of article'. To be published in *Title of Journal*, Volume and issue numbers [peer-reviewed accepted version]. Available at: DOI or URL (Accessed: date).

## Enquiries

If you have questions about this document contact [ResearchSupport@kent.ac.uk](mailto:ResearchSupport@kent.ac.uk). Please include the URL of the record in KAR. If you believe that your, or a third party's rights have been compromised through this document please see our [Take Down policy](https://www.kent.ac.uk/guides/kar-the-kent-academic-repository#policies) (available from <https://www.kent.ac.uk/guides/kar-the-kent-academic-repository#policies>).

# Mass Flow Measurement of Two-phase Carbon Dioxide Using Coriolis Flowmeters

Lijuan Wang<sup>a,b</sup>, Jinyu Liu<sup>b</sup>, Yong Yan<sup>b</sup>, Xue Wang<sup>c</sup>, Tao Wang<sup>d</sup>

<sup>a</sup> School of Control and Computer Engineering

North China Electric Power University, Beijing 102206, China

<sup>b</sup> School of Engineering and Digital Arts

University of Kent, Canterbury, Kent CT2 7NT, U.K.

<sup>c</sup> School of Mathematics, Statistics and Actuarial Science

University of Kent, Canterbury, Kent CT2 7NF, U.K.

<sup>d</sup> KROHNE Ltd., 34-38 Rutherford Drive, Wellingborough NN8 6AE, U.K.

**Abstract**—Carbon Capture and Storage (CCS) is considered as an important technology to reduce CO<sub>2</sub> emission from electrical power generation and other industrial processes. In the CCS chain, i.e. from capture to storage via transportation, it is essential to realize accurate measurement of CO<sub>2</sub> flows for the purpose of accounting and potential leakage detection. However, there are some significant challenges for the current flow metering technologies to achieve the specified 1.5% measurement uncertainty in the EU-ETS (European Union - Emissions Trading Scheme) for all expected flow conditions. Moreover, there are very few CO<sub>2</sub> flow test and calibration facilities that can recreate CCS conditions particularly two-phase CO<sub>2</sub> flow in pipelines together with accurate measurement standards. As one of the most potential flowmeters that may be used in the CCS chain, Coriolis flowmeters have the advantages of direct measurement of mass flow rate regardless of its state (liquid, gas, gas/liquid two-phase or supercritical) in addition to the measurement of temperature and density of CO<sub>2</sub> for the characterization of flow conditions. This paper assesses the performance of Coriolis flowmeters incorporating a soft-computing correction method for gas-liquid two-phase CO<sub>2</sub> flow measurement. The correction method includes a pre-trained backpropagation neural network. Experimental work was conducted on a purpose-built 25 mm bore two-phase CO<sub>2</sub> flow test rig for liquid mass flowrate between 300 kg/h and 3050 kg/h and gas mass flowrate from 0 to 330 kg/h under the fluid temperature of 19~21 °C and pressure of 54~58 bar. Experimental results suggest that the Coriolis flowmeters with the developed correction method are capable of providing the mass flow rate of gas-liquid CO<sub>2</sub> flow with errors mostly within  $\pm 2\%$  and  $\pm 1.5\%$  on horizontal and vertical pipelines, respectively.

**Keywords**—CCS; gas-liquid CO<sub>2</sub> flow; flow measurement; Coriolis mass flowmeter; gas volume fraction;

## I. INTRODUCTION

Carbon capture and storage (CCS) is an effective technology to reduce CO<sub>2</sub> emissions into the atmosphere and thus mitigate global warming and ocean acidification. For the commercial and regulatory purposes, the accurate measurement and accounting of CO<sub>2</sub> is essential throughout the CCS chain.

Pipelines are considered to be the most viable method for onshore transportation of high volume of CO<sub>2</sub> from capture facilities to storage sites through long distances. The typical range of pressure and temperature of a CO<sub>2</sub> pipeline under CCS conditions is between 85 and 150 bar, and between 13°C to 44°C, respectively, to ensure a stable single phase flow through the pipeline [1]. However, it is extremely difficult to regulate the pressure and temperature over long distances and during transitions (e.g. start-up of the transportation). Moreover, the CO<sub>2</sub> transition boundaries between phases are very close and lie around ambient conditions. For these reasons very small variations in temperature and pressure may lead to rapid and substantial changes in the CO<sub>2</sub> physical properties (gas, liquid, two-phase or supercritical). This also imposes significant challenges to the measurement and control of CO<sub>2</sub> flows in CCS pipelines.

With regard to CO<sub>2</sub> flow metering, Orifice plate meters and turbine meters have been used in general single-phase CO<sub>2</sub> measurement in Enhanced Oil Recovery (EOR) projects for many years [2]. However, the Orifice plate and differential-pressure metering used for slugging two-phase mixture measurement at the well-head is reported to give errors up to 80% [3]. Coriolis flowmeters, as one of the most accurate single-phase mass flowmeters, were applied to gas or liquid CO<sub>2</sub> single-phase flow measurement [4, 5]. In recent years, some researchers have attempted to use Coriolis flowmeters for two-phase or multiphase flow measurement. Coriolis flowmeters incorporating with a bubble-effect model, a neural network, a fuzzy inference system and additional meters such as an ultrasonic flowmeter were proposed for air-water two-phase flow measurement [6-13]. However, gas-liquid two-phase CO<sub>2</sub> flow is more difficult to measure than air-water two-phase flow as the phase transition between liquid and gas may take place during the measurement. For two-phase CO<sub>2</sub> flow measurement, commercial Coriolis mass flowmeters were field-tested with slugging two-phase CO<sub>2</sub> flow and the difference between the Coriolis flowmeters under test and the reference meter was 5% [3]. However, the characteristics of the two-phase CO<sub>2</sub> flow were not described and the effect of flow patterns on the performance of the Coriolis flowmeters was not quantitatively reported.

---

The authors would like to acknowledge the financial support of the UK CCS Research Centre ([www.ukccsrc.ac.uk](http://www.ukccsrc.ac.uk)) in carrying out this work. The UKCCSRC is funded by the EPSRC as part of the RCUK Energy Programme.

In this study, the performance of Coriolis flowmeters manufactured by KROHNE (OPTIMASS 6400 S15) to measure gas-liquid CO<sub>2</sub> flow was investigated through a series of experimental tests. The original errors of Coriolis flowmeters on horizontal and vertical installations are presented and interpreted. Two parameters of interest from the Coriolis flowmeters, i.e. including apparent mass flowrate and density drop, are analyzed over a range of mass flowrates of liquid CO<sub>2</sub> and entrained gaseous CO<sub>2</sub>. Based on the experimental data, two backpropagation neural networks with three layers are established as the soft-computing correction methods for the Coriolis flowmeter in horizontal and vertical installations respectively. The corrected errors of the Coriolis flowmeters for two-phase CO<sub>2</sub> flow measurement on both positions are reported.

## II. METHODOLOGY

The basic principle and structure of the measurement system is shown in Fig. 1. The Coriolis flowmeter provides mass flow rate and density of the fluid through analyzing and processing the internal vibration signals [6]. Even though the mass flow rate and density from the flowmeter are erroneous under two-phase flow conditions, the apparent mass flowrate and observed density drop still can reflect the variations of true flowrate and gas volume fraction to some extent. The correction method to be incorporated in the flowmeter to correct the apparent mass flow rate of two-phase CO<sub>2</sub> is based on a pre-trained BP-ANN (Backpropagation-Artificial Neural Network).

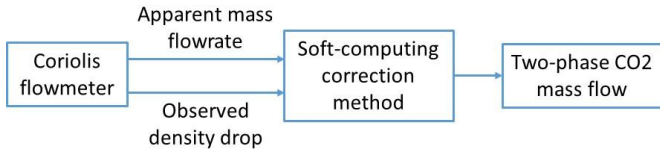

Fig. 1. Principle and structure of the measurement system.

The structure of the BP-ANN consists of an input layer, a hidden layer and an output layer. The apparent mass flowrate and observed density drop from the flowmeter are the two input variables for the BP-ANN. The number of neurons ( $N^H$ ) in the hidden layer is determined using the equations below, as proposed by Hecht-Nielson and Rogers and Dowla [14]:

$$N^H \leq 2N^I + 1 \quad (1)$$

$$N^H \leq \frac{N^{TR}}{N^I + 1} \quad (2)$$

where  $N^I$  and  $N^{TR}$  are the numbers of input variables and training samples, respectively. However, equations (1) and (2) give only the range of  $N^H$ . The exact  $N^H$  for a NN can be selected through a trial-and-error test and trade-off between minimizing errors and achieving good generalization capability of the NN. The output layer has only one node which is the mass flowrate of two-phase CO<sub>2</sub> flow. The transfer function between the input and hidden layers is the hyperbolic tangent sigmoid transfer function. The pure linear function is taken as

the transfer function connecting the hidden layer to the output layer. The training function is the Bayesian regularization whilst the learning function is gradient descent with momentum weight and bias learning function. Training stops when the maximum number of epochs is reached or the performance is minimized to the goal.

## III. EXPERIMENTAL RESULTS AND DISCUSSION

### A. Test Facility and Test Conditions

Fig. 2 shows the schematic of the two-phase CO<sub>2</sub> flow test facility. As shown in Fig. 3, two independent Coriolis flowmeters were installed before the mixer to provide references for the individual mass flow rates of the liquid and gas CO<sub>2</sub> phases. The reference Coriolis flowmeters equipped on the facility offer uncertainties of 0.16% for CO<sub>2</sub> liquid flows and 0.3% for CO<sub>2</sub> gas flows [15]. In the downstream, two additional Coriolis flowmeters of the same type were installed in the horizontal and vertical test sections, respectively. These are the meters under test to assess their performance of the developed correction method. In view of the effects of gravity and buoyancy on two-phase fluid, both horizontal and vertical installations of the meters are considered. Temperature, pressure and DP transducers were also installed to record the flow conditions in the pipelines.

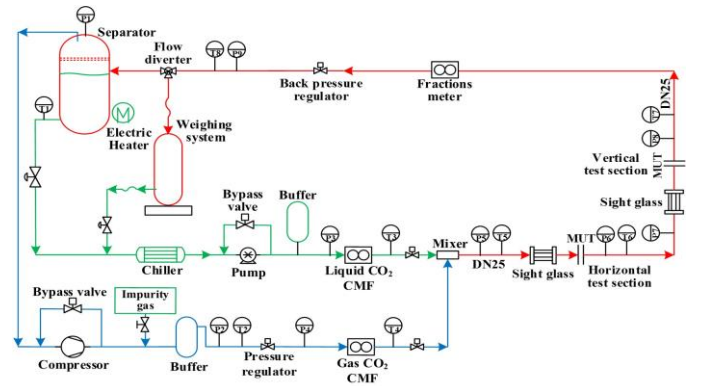

Fig. 2. Schematic of the two-phase CO<sub>2</sub> flow test facility.

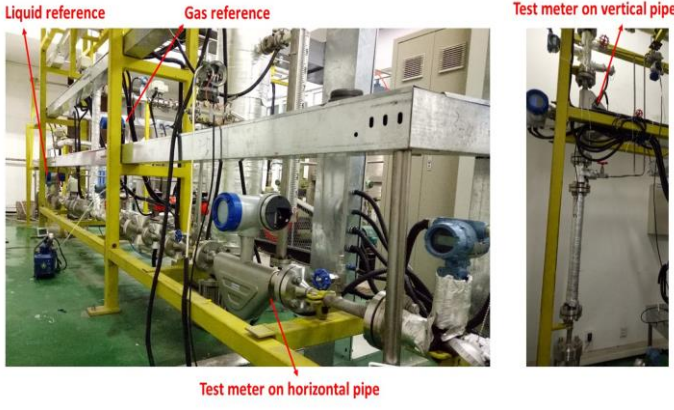

Fig. 3. Photos of part of the test facility.

Experimental work was conducted under the fluid temperature of 19~21 °C and pressure of 54~58 bar. The liquid and gas CO<sub>2</sub> mass flowrates range from 300 kg/h to 3050 kg/h and from 0 to 330 kg/h, respectively. The test points in terms of liquid CO<sub>2</sub> mass flowrate and gas CO<sub>2</sub> mass flowrate are plotted in Fig. 4. A total of 128 data sets (circular markers in Fig. 4, representing liquid flowrates of 400, 800, 1300, 1800, 2300 and 3050 kg/h) were collected for the purpose of training the neural networks whilst 55 data sets (triangular markers in Fig. 4, presenting liquid flowrates of 300, 550, 1050, 1550, 2050 and 2550 kg/h) for testing the networks. Each data set represents the average of all recorded values within an approximate window of 100 seconds. On the horizontal test section three typical flow regimes were observed, including stratified flow, intermittent flow and dispersed flow. The flow pattern on the vertical test section includes bubbly flow, intermittent flow and dispersed flow.

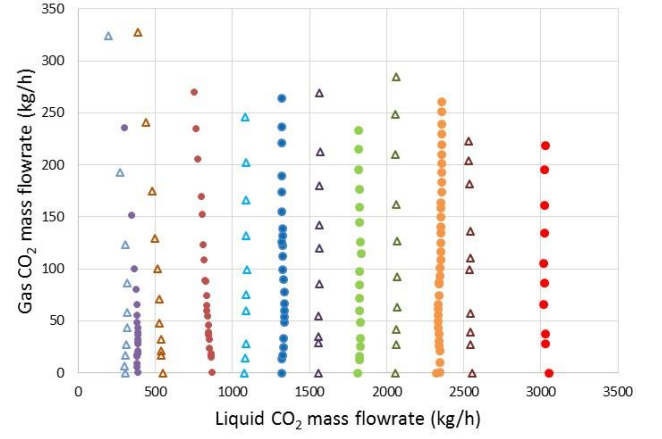

Fig. 4. Experimental test points of gas-liquid CO<sub>2</sub> two-phase flow.

### B. Sensor Parameters

Several parameters including gas volume fraction, reference mass flowrate, apparent mass flowrate and observed density drop are analyzed to quantify the behavior of two-phase CO<sub>2</sub> flow.

Gas volume fraction  $\alpha$  in the process pipe is defined as the quantity of gas CO<sub>2</sub> entrained into liquid CO<sub>2</sub> flows and calculated from

$$\alpha = \frac{q_{v,g}}{q_{v,l} + q_{v,g}} \times 100\% \quad (3)$$

where  $q_{v,l}$  and  $q_{v,g}$  are the volume flowrates of liquid and gas phases from the reference flowmeters. According to the experimental conditions set in Section III A, the gas volume fraction can go up to 87% at the liquid CO<sub>2</sub> flowrate of 300 kg/h.

Reference mass flowrate ( $q_{m,r}$ ) is defined as the sum of liquid and gas CO<sub>2</sub> mass flowrate, which is calculated by

$$q_{m,r} = q_{m,l} + q_{m,g} \quad (4)$$

where  $q_{m,l}$  and  $q_{m,g}$  are the mass flow rates of liquid and gas phases from the reference flowmeters. In the following analysis the reference mass flowrate is regarded as the expected mass flow to calculate the relative error of the mass flowrate from a Coriolis flowmeter under test.

The apparent mass flowrate is the direct output from a Coriolis flowmeter. The Coriolis flowmeter has enjoyed much success in measuring single-phase flow. However, due to the influence of the entrained gas, the apparent mass flowrate is no longer the expected mass flow rate of the mixture flow, but the error has been found reproducible. Fig. 5 depicts how the

apparent mass flowrates from the Coriolis flowmeters on horizontal and vertical sections changes with the reference values of the liquid mass flowrate and gas volume fraction. The apparent and reference mass flowrates are somehow related.

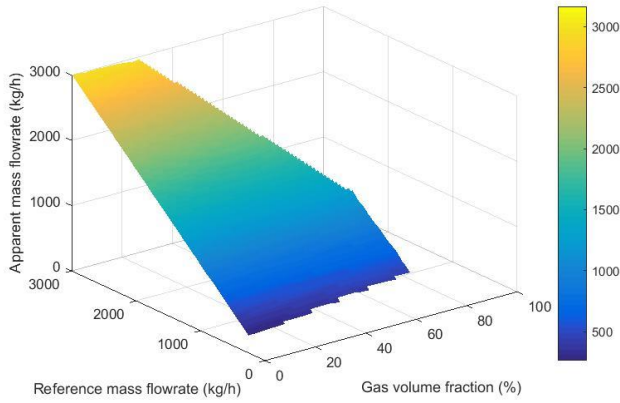

(a) Coriolis flowmeter in horizontal installation.

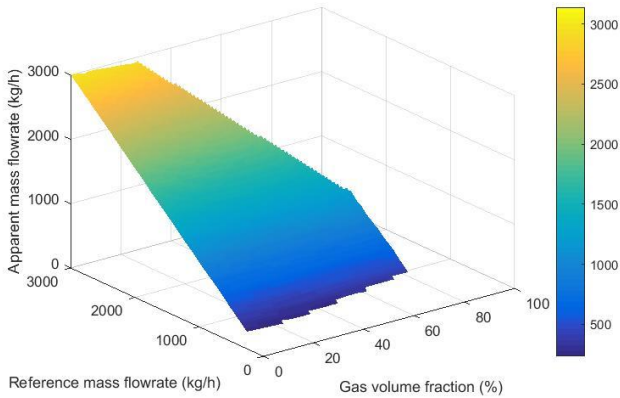

(b) Coriolis flowmeter in vertical installation.

Fig. 5. Apparent mass flowrate under two-phase CO<sub>2</sub> flow.

The observed density deviates dramatically from the liquid density as the gas CO<sub>2</sub> entrained into the liquid CO<sub>2</sub> flow. The observed density deviation (or drop) is determined from the density of the single liquid flow ( $\rho_l$ ) and the apparent density ( $\rho$ ) from the Coriolis flowmeter under test:

$$d = \frac{\rho_l - \rho}{\rho_l} \times 100\% \quad (5)$$

Fig. 6 shows observed density drop as a function of the liquid mass flowrate and gas volume fraction of CO<sub>2</sub> flow. As more gas is fed into the pipe, the gas volume fraction goes up and density drops quickly. Although the density is also subject to similar errors as the mass flow measurement due to the nature of the two-phase flow, it however can be used as an indicator of gas volume fraction.

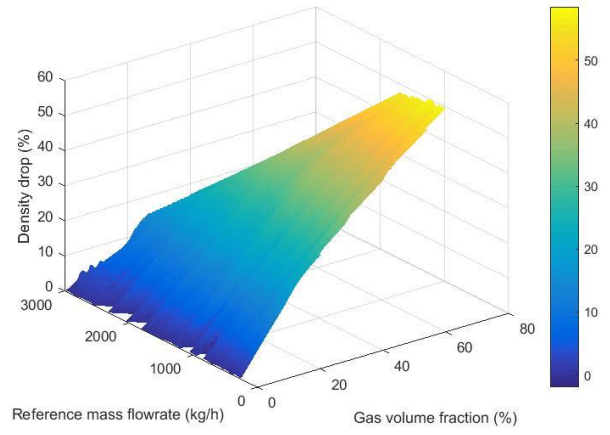

(a) Coriolis flowmeter in horizontal installation.

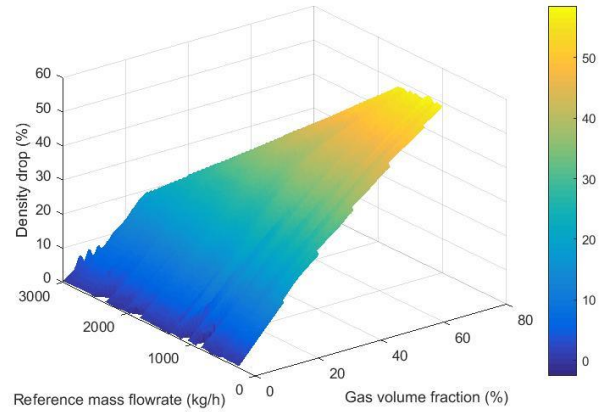

(b) Coriolis flowmeter in vertical installation.

Fig. 6. Observed density drop under two-phase CO<sub>2</sub> flow conditions.

### C. Mass Flowrate Correction

The typical uncorrected mass flow errors of the Coriolis flowmeters on horizontal and vertical test sections are plotted in Fig. 7. When the liquid mass flowrate is lower than 800 kg/h, gas and liquid are completely separated and form stratified flow in the horizontal test pipe. The high volume of gas in the liquid makes the Coriolis flowmeter on the horizontal position produces large positive errors. The flowmeter on the vertical position gives smaller errors as bubbles go upwards in the liquid. The intermittent flow with high liquid flowrate and less gas entrainment has little effect on the performance of Coriolis flowmeters on both horizontal and vertical positions. As gas CO<sub>2</sub> increases, the two Coriolis flowmeters generate negative errors for the dispersed flow. Different flow patterns of the two-phase flow tend to show different trends on the error curves due to the chaotic nature of the gas phase distribution within the liquid. The meter orientation also affects the phase distribution in the flow tubes. In the horizontal installation, the flow tubes are in downward position and bubbles may get trapped on the inlet side at low rates due to the buoyancy effect. Consequently, the mass flow errors of Coriolis flowmeters are either positive or negative and have different trends from horizontal and vertical installations.



Thanks to the new generation flow transmitter, the results for the same installation are reproducible [7].

Each neural network was trained with 128 data sets and then employed on additional 55 test data sets. As shown in Fig. 4, the test data are different from the training data in terms of liquid CO<sub>2</sub> mass flowrate and gas CO<sub>2</sub> entrainment. The training and test data were acquired from the same test rig (see Fig. 3) with a pipe diameter of 25 mm. Coriolis flowmeters were tested on both horizontal and vertical positions and the flow patterns covered stratified flow, intermittent flow and dispersed flow on the horizontal section and bubbly flow, intermittent flow and dispersed flow on the vertical section.

Each pre-trained neural network consists of an input layer, a hidden layer and an output layer. The input layer accepts two inputs, i.e. apparent mass flowrate and observed density drop. The hidden layer has five neurons, which is determined according to equations (1) and (2) and a trial-and-error test. The output layer is the estimated two-phase CO<sub>2</sub> mass flowrate.

The mass flow errors in Fig. 8 are the results processed through the correction method, i.e. the original errors have been corrected via the established neural network. For the horizontal installation, the relative errors of the corrected mass flowrates are mostly reduced to  $\pm 2\%$ , except for some large errors at lower flowrate (below 550 kg/h) due to large original errors at the low flowrate. The performance of the Coriolis flowmeter on the vertical section outperforms the one on the horizontal installation as the relative errors are mostly within  $\pm 1.5\%$ .

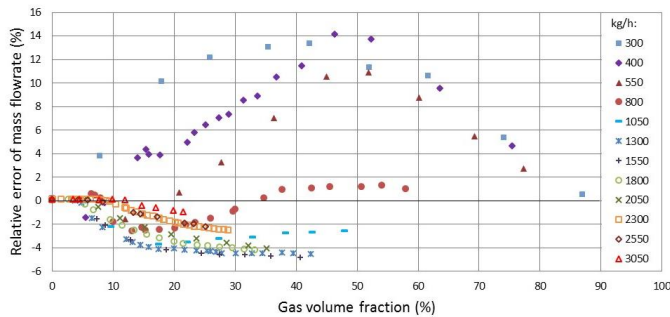

(a) Coriolis flowmeter in horizontal installation.

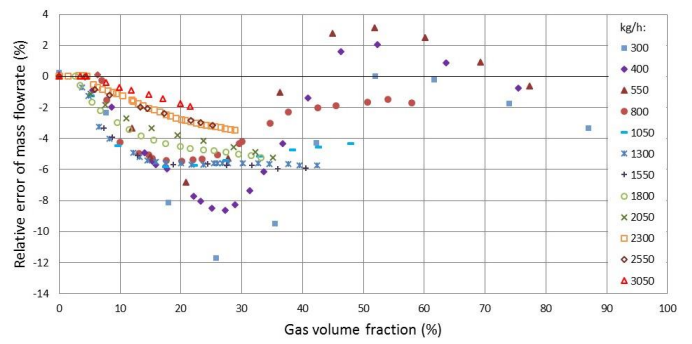

(b) Coriolis flowmeter in vertical installation.

Fig. 7. Relative errors of mass flowrate from Coriolis flowmeters without the correction method.

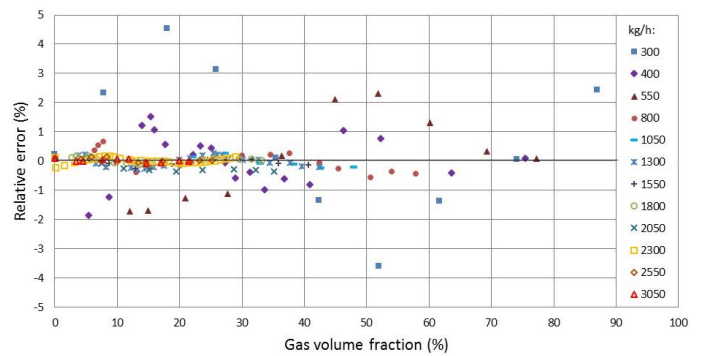

(a) Coriolis flowmeter in horizontal installation.

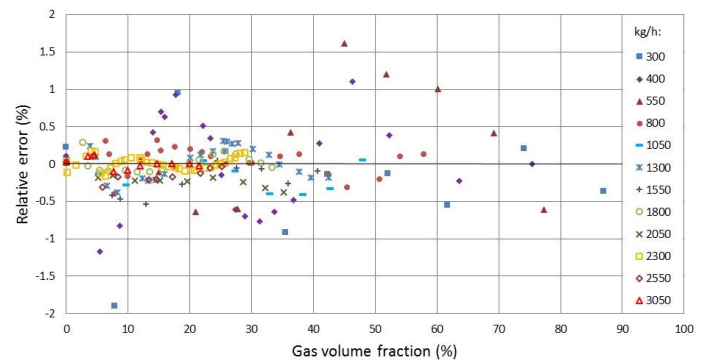

(b) Coriolis flowmeter in vertical installation.

Fig. 8. Relative errors of mass flowrate from Coriolis flowmeters with the correction method.

#### IV. CONCLUSIONS

The performance of Coriolis flowmeters with a BP-ANN based correction method has been studied for gas-liquid two-phase CO<sub>2</sub> flow measurement under different installation conditions. The validity of the proposed method has been verified through a range of experimental tests on a purpose-built two-phase CO<sub>2</sub> test rig. Experimental results presented have suggested that the relative errors of mass flowrate from the Coriolis flowmeters with the correction method are mostly within  $\pm 2\%$  and  $\pm 1.5\%$ , respectively, for the horizontal and vertical installations. In comparison with the original uncorrected errors, this approach has provided significant improvement in measurement accuracy under two-phase CO<sub>2</sub> flow conditions. This outcome has effectively extended the applicability of Coriolis mass flowmeters from single-phase flow measurement to two-phase CO<sub>2</sub> flow measurement under CCS conditions. Effort will be made in the future to measure multiphase CO<sub>2</sub> flows with impurities.

#### REFERENCES

- [1] D. Leung, G. Garamanna, M. Maroto-Valer, "An overview of current status of carbon dioxide capture and storage technologies," *Renew. Sust. Energ. Rev.*, vol. 39, pp. 426-443, Nov. 2014.
- [2] L. Hunter and G. Leslie, "National physical laboratory (NPL): A study of measurement issues for carbon capture and storage (CCS)," TUV NEL Ltd, Glasgow, U.K., Tech. Rep. 2009/54, 2009.
- [3] T. Green, M. Reese and M. Henry, "Two-phase CO<sub>2</sub> measurement and control in the Yates oil field," *Measurement and Control*, vol. 41, no. 7, pp. 205-207, Sep. 2008.
- [4] K. Adefila, Y. Yan, L. Sun and T. Wang, "Calibration of an averaging pitot tube for gaseous CO<sub>2</sub> flowmetering," *IEEE Trans. Instrum. Meas.*, vol. 64, no. 5, pp. 1240-1249, May 2015.
- [5] C. Lin, A. Bhattacharji, G. Spicer and M. Maroto-Valer, "Coriolis Metering Technology for CO<sub>2</sub> Transportation for Carbon Capture and Storage," *Energy Procedia*, vol. 63, pp. 2723-2726, 2014.
- [6] T. Wang and R. Baker, "Coriolis flowmeters: a review of developments over the past 20 years, and an assessment of the state of the art and likely future directions," *Flow Meas. Instrum.*, vol. 40, pp. 99-123, Sep. 2014.
- [7] J. W. Kunze, R. Storm and T. Wang, "Coriolis mass flow measurement with entrained gas," in *Proc. of Sensors and Measuring Systems 2014*; 17. ITG/GMA Symposium, Nürnberg, 2014.
- [8] J. Hemp and G. Sultan, "On the theory and performance of Coriolis mass flowmeters," in *Proc. of the International Conference on Mass flow measurement Direct and Indirect*, 1989.
- [9] R. Liu, M. Fuent, M. Henry and M. Duta, "A neural network to correct mass flow errors caused by two-phase flow in a digital Coriolis mass flowmeter," *Flow Meas. Instrum.*, vol. 12, no. 1, pp. 53-63, Sep. 2001.
- [10] B. Safarinejadian, M. Tajeddini and L. Mahmoodi, "A new fuzzy based method for error correction of Coriolis mass flow meter in presence of two-phase fluid," in *Proc. of International Conference on Artificial Intelligence and Image Processing*, pp. 192-196, 2012.
- [11] Q. Hou, K. Xu, M. Fang, Y. Shi, B. Tao and R. Jiang, "Gas-liquid two-phase flow correction method for digital CMF," *IEEE Trans. Instrum. Meas.*, vol. 63, no. 10, pp. 2396-2404, Mar. 2014.
- [12] L. Xing, Y. Geng, C. Hua, H. Zhu and A. Rieder, "A combination method for metering gas-liquid two-phase flows of low liquid loading applying ultrasonic and Coriolis flowmeters," *Flow Meas. Instrum.*, vol. 37, pp. 135-143, Jan. 2014.
- [13] L. Wang, J. Liu, Y. Yan, X. Wang and T. Wang, "Gas-liquid two-phase flow measurement using Coriolis flowmeters incorporating neural networks," in *Proc. of IEEE Int. Instrum. Meas. Technol. Conf.*, pp. 747-751, Taipei, Taiwan, 23-26 May 2016.
- [14] G. Bowden, H. Maier and G. Dandy, "Input determination for neural network models in water resources applications. Part 2. Case study: forecasting salinity in a river," *J. Hydrol.*, vol. 301, no. 1-4, pp. 93-107, 2005.
- [15] [On-line] CO<sub>2</sub> flow metering through multi-modal sensing and statistical data fusion, Autumn 2016 Biannual Meeting, Edinburgh, 14-15, Sep. 2016.  
[https://ukccsrc.ac.uk/sites/default/files/documents/event/edinburghBASEp16/edinburgh\\_biannual\\_sep16\\_proceedings\\_final.pdf](https://ukccsrc.ac.uk/sites/default/files/documents/event/edinburghBASEp16/edinburgh_biannual_sep16_proceedings_final.pdf) Accessed 28 October 2016