



# Kent Academic Repository

Zhang, Kangkang, Jiang, Bin, Yan, Xinggang and Mao, Zehui (2016) *Incipient sensor fault estimation and accommodation for inverter devices in electric railway traction systems*. *International Journal of Adaptive Control and Signal Processing*, 31 (5). pp. 785-804. ISSN 0890-6327.

## Downloaded from

<https://kar.kent.ac.uk/58507/> The University of Kent's Academic Repository KAR

## The version of record is available from

<https://doi.org/10.1002/acs.2730>

## This document version

Author's Accepted Manuscript

## DOI for this version

## Licence for this version

UNSPECIFIED

## Additional information

## Versions of research works

### Versions of Record

If this version is the version of record, it is the same as the published version available on the publisher's web site. Cite as the published version.

### Author Accepted Manuscripts

If this document is identified as the Author Accepted Manuscript it is the version after peer review but before type setting, copy editing or publisher branding. Cite as Surname, Initial. (Year) 'Title of article'. To be published in *Title of Journal*, Volume and issue numbers [peer-reviewed accepted version]. Available at: DOI or URL (Accessed: date).

## Enquiries

If you have questions about this document contact [ResearchSupport@kent.ac.uk](mailto:ResearchSupport@kent.ac.uk). Please include the URL of the record in KAR. If you believe that your, or a third party's rights have been compromised through this document please see our [Take Down policy](https://www.kent.ac.uk/guides/kar-the-kent-academic-repository#policies) (available from <https://www.kent.ac.uk/guides/kar-the-kent-academic-repository#policies>).

# Incipient Sensor Fault Estimation and Accommodation for Inverter Devices in Electric Railway Traction Systems

Kangkang Zhang<sup>1,2</sup>, Bin Jiang<sup>1,2,\*</sup>, Xing-Gang Yan<sup>3</sup>, Zehui Mao<sup>1,2</sup>

## Abstract

This paper proposes an incipient sensor fault estimation and accommodation method for three-phase PWM inverter devices in electric railway traction systems. First, the dynamics of inverters and incipient voltage sensor faults are modelled. Then, for the augmented system formed by original inverter system and incipient sensor faults, an optimal adaptive unknown input observer is proposed to estimate the inverter voltages, currents and the incipient sensor faults. The designed observer guarantees that the estimation errors converge to the minimal invariant ellipsoid. Moreover, based on the output regulator via internal model principle, the fault accommodation controller is proposed to ensure that the  $v_{od}$  and  $v_{oq}$  voltages track the desired reference voltages with the tracking error converging to the minimal invariant ellipsoid. Finally, simulations based on the traction system in CRH2 (China Railway High-speed) are presented to verify the effectiveness of the proposed method.

**keywords:** Incipient sensor faults, fault estimation and accommodation, inverter devices, railway traction system.

## I. INTRODUCTION

Safety is the first concern in high-speed railway operation, which is greatly dependent on the reliability of information control systems of high-speed trains. The traction drive subsystem is the core of information control systems in high-speed train systems, which plays an important

<sup>1</sup>College of Automation Engineering, Nanjing University of Aeronautics and Astronautics, Nanjing 210016, China, (e-mail: KangZhang359@163.com; binjiang@nuaa.edu.cn; zehuimao@nuaa.edu.cn).

<sup>2</sup>Jiangsu Key Laboratory of Internet of Things and Control Technologies (Nanjing Univ. of Aeronautics and Astronautics).

<sup>3</sup>School of Engineering and Digital Arts, University of Kent, Canterbury, Kent CT2 7NT, United Kingdom, (e-mail: x.yan@kent.ac.uk).

\* Corresponding author. Email: binjiang@nuaa.edu.cn

role in electric railway running safety. Therefore, the fault diagnosis and FTC (fault-tolerant control) mechanism are necessary for modern high-speed railway systems, especially for the traction subsystems.

Modern railway traction power systems are fed by  $2 \times 25\text{KV}/50\text{Hz}$  single phase ac current sources in [1] or by  $1500\text{V}$  dc voltage from electric railway substations in [2]. A typical ac/dc/ac power system used for electrical traction drives is shown in Fig. 1 (see, e.g. [3]), which includes a catenary, a voltage transformer, a single phase PWM rectifier, a three-phase PWM inverter and driving motors. In the traction systems, the electric power is transmitted to the drive motors

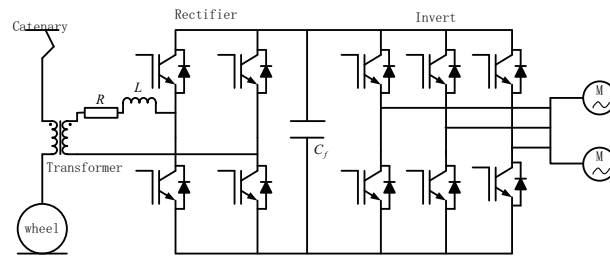

Fig. 1. Railway traction circuit schematic diagram.

through catenaries, voltage transformers, single phase PWM rectifiers and three-phase PWM inverters. The inverter is driven by the dc link voltage, provided by the rectifier, while the driving motors are driven directly by the three-phase PWM inverter which affects the motion performance of the driving motors greatly. Over a long period of time, aging components, such as electrolyte loss effectiveness of electrolytic capacitors, in the current sensors and voltage sensors, may deduce incipient faults, and further develop to serious failures, which would degrade performance of the total traction systems seriously. Therefore, early incipient sensor fault diagnosis and FTC should be designed and achieved to improve the reliability of the electric traction system.

Typically, abrupt faults affect safety-relevant systems where hard-failures have to be detected early enough so that catastrophic consequences can be avoided by early system reconfiguration. On the other end, incipient faults are closely related to maintenance problems and early detection of worn equipment is necessary. In this case, the incipient faults are typically small and not easy to be detected (see, e.g. [4] and [5]). In order to well plan maintenance in advance, it is necessary to estimate the incipient faults as accurately as possible. In addition, fault estimation (FE) is one of the most important components in active fault-tolerant control (AFTC), and work on FE is discussed extensively in literature: see for example [5], [6], [7], [16], [19], [22] and [30]. Most of AFTC schemes require ‘precise’ fault estimation as in [8] and [10]. Nevertheless, ‘precise’

estimation of incipient faults is very challenging since incipient faults are so small that can be drowned by disturbances and uncertainties. Therefore, it is significant to minimize the effect of disturbances and uncertainties on incipient fault estimation.

During the past several decades, there are many results about the incipient fault estimation, such as [11], [12] [13], [14], [15], [16] and [17]. Different adaptive fault estimation modules are proposed to estimate the fault parameters in [14], [15] and [22]. However, it is still very challenging to apply these adaptive approaches to estimate incipient faults, especially in the presence of disturbances and uncertainties. In [18], the adaptive approach and  $\mathcal{H}_\infty$  theory are combined together such that the estimated parameters satisfy the optimal performance index under the  $\mathcal{L}_2$  disturbances. In [31], an invariant ellipsoid method is proposed to deal with  $\mathcal{L}_\infty$  disturbances, which motivates us to combine the adaptive approach and invariant ellipsoid method to estimate incipient fault parameters. In terms of sensor FTC, fault estimation can be used directly to ‘correct’ the sensor measurement before the erroneous information is used by the controller [23]. However, in inverter systems, there are unmatched unknown inputs which cannot be compensated through input channels directly. The output regulator [24] via adaptive internal model principle proposed in [25] provides an efficient method to reject the unmatched unknown inputs in the output channels. Therefore, this work will develop an adaptive fault estimation module and a fault-tolerant controller to ensure that the estimation errors and voltage tracking errors converge into minimal invariant ellipsoids in the presence of disturbances.

In this paper, the incipient voltage sensor faults in inverter devices are considered. The invariant ellipsoid method, adaptive unknown input observer and output regulator are combined to develop an optimal sensor fault estimation module and incipient sensor fault accommodation method for the inverter devices. The main contribution of this paper is summarized as follows.

- 1) An optimal adaptive unknown input observer is designed such that the estimation errors converge to the minimal invariant ellipsoid.
- 2) A novel optimal fault-tolerant controller is proposed to “correct” faulty sensor outputs such that the tracking errors converge to the minimal invariant ellipsoid.
- 3) The designed optimal fault estimation method and optimal fault accommodation (FA) method are applied to the practical three-phase PWM inverter system successfully.

The rest parts of this paper are organized as follows. In Section II, the dynamics of three-phase PWM inverters with incipient sensor faults are modelled. Preliminaries and assumptions are presented. In Section III, an optimal adaptive unknown input observer is designed based on the system decomposition. The incipient sensor fault is estimated in Section IV. In Section V,

the optimal fault-tolerant controller based on the output regulator and internal model principle is proposed. In section VI, the designed adaptive unknown input observer and fault-tolerant controller are applied to the three-phase PWM inverter of the traction system in China Railway High-speed to verify the effectiveness of the obtained results. Section VII concludes this paper.

## II. PROBLEM FORMULATION

### A. Dynamic Modeling of Inverter

The topology structure of the inverter device used in the CRH2's traction system is shown in Fig. 2, where  $L_f$ ,  $C_f$  and  $r$  are the filter inductor, capacitor and equivalent resistance, respectively,  $V_{dc}$  is the dc voltage source,  $v_{jn}$ ,  $j = a, b, c$  are the inverter bridge voltages,  $v_{oj}$  and  $i_{oj}$ ,  $j = a, b, c$  are the load voltages and currents, respectively. From Fig.2, based on the Kirchoff current and

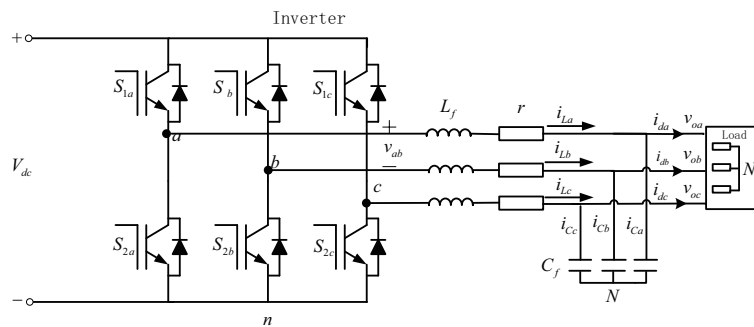

Fig. 2. Three-phase PWM inverter topology

voltage principles, the currents and voltages of  $a, b, c$  phases satisfy

$$i_{La} + i_{Lb} + i_{Lc} = 0, \quad (1)$$

$$L_f \frac{di_{Lj}}{dt} + ri_{Lj} + v_{oj} = v_{jN} + v_{jn}, \quad (2)$$

$$C_f \frac{dv_{oj}}{dt} = i_{Lj} - i_{oj}, \quad j = a, b, c \quad (3)$$

where

$$v_{jn} = S_j V_{dc}, \quad (4)$$

$$v_{jN} = -\frac{1}{3} \sum_{r=a,b,c} S_r V_{dc}, \quad j = a, b, c, \quad (5)$$

with  $S_j$  being IGBT's switching control signals. Then the inverter system is expressed by

$$\frac{dv_{oj}}{dt} = \frac{i_{Lj}}{C_f} - \frac{i_{oj}}{C_f}, \quad (6)$$

$$\frac{di_{Lj}}{dt} = -\frac{ri_{Lj}}{L_f} + \frac{v_{oj}}{L_f} + \frac{V_{dc}}{L_f}u, \quad j = a, b, c, \quad (7)$$

$$e_{yr} = v_o - y_r \quad (8)$$

where  $u = \left( S_j - \frac{1}{3} \sum_{r=a,b,c} S_r \right)$ ,  $v_o = \text{col}(v_{oa}, v_{ob}, v_{oc})$  and  $y_r$  is output voltage reference signal.

By introducing the Clarke and Park coordinate transformation  $x_{dq} = T_{dq}x_{abc}$  where the expression of  $T_{dq}$  refers to [26], Eqs. (6), (7) and (8) become

$$\dot{x} = Ax + Bu + Ei_o, \quad (9)$$

$$e_{yr} = Cx - y_r$$

where  $x = \text{col}(v_{od}, v_{oq}, i_{Ld}, i_{Lq})$ ,  $i_o = \text{col}(i_{od}, i_{oq})$ ,

$$A = \begin{bmatrix} 0 & \omega_0 & \frac{1}{C_f} & 0 \\ -\omega_0 & 0 & 0 & \frac{1}{C_f} \\ -\frac{1}{L_f} & 0 & -\frac{r}{L_f} & \omega_0 \\ 0 & -\frac{1}{L_f} & -\omega_0 & -\frac{r}{L_f} \end{bmatrix}, \quad B = \begin{bmatrix} 0 & 0 \\ 0 & 0 \\ \frac{V_{dc}}{L_f} & 0 \\ 0 & \frac{V_{dc}}{L_f} \end{bmatrix}, \quad E = \begin{bmatrix} -\frac{1}{C_f} & 0 \\ 0 & -\frac{1}{C_f} \\ 0 & 0 \\ 0 & 0 \end{bmatrix}$$

and

$$C = \begin{bmatrix} 1 & 0 & 0 & 0 \\ 0 & 1 & 0 & 0 \end{bmatrix}$$

with  $\omega_0$  being constant operation frequency of the inverter device.

**Remark 1.** It should be pointed out that the outputs  $S_j$ ,  $j = a, b, c$  of PWM producer in (4) and (5) are measurable, which implies that  $u$  in (9) are measurable. Also, the load currents  $i_o$  in inverter system (9) are measurable. Therefore, both the control signals  $u$  and the load currents  $i_o$  in (9) can be used in observer design and will not affect fault signal estimation.  $\nabla$

### B. Incipient Sensor Fault Modeling

Since incipient faults are small in amplitude, piecewise continuous and develop slowly, they can be modeled based on the following lemma.

**Lemma 1.** [21] For any piecewise continuous vector function  $f : \mathcal{R}^+ \rightarrow \mathcal{R}^q$ , and a stable  $q \times q$  matrix  $A_f$ , there always exists an input vector  $\xi \in \mathcal{R}^q$  such that  $\dot{f} = A_f f + \xi$ .

From Lemma 1, incipient faults  $f(t)$  can be modeled by

$$\dot{f} = A_f f + \xi, \quad f(0) = 0 \quad (10)$$

where  $A_f$  is a stable matrix with appropriate dimensions, and  $\xi = [\xi_1^T, \dots, \xi_q^T]^T \in \mathcal{R}^q$  is an unknown vector. Taking the Laplace transformation on Eq. (10), it is clear to see that in the frequency domain,  $f(s) = (sI - A_f)^{-1}\xi$ , which shows that the fault signal  $f$  is determined by  $\xi$  completely. It should be noted that  $A_f$  is not the designed parameter and that only the fault modeled by (10) is considered in this paper, which may limit the application of the developed results. However, such a class of faults widely exists in reality such as flight control systems and electric motor systems, and it has been well studied in [5] and [27].

### C. Preliminaries and Assumptions

Consider a class of linear systems described by

$$\begin{aligned} \dot{x} &= Ax + Bu + Ei_0 + Ed, \\ e_{yr} &= Cx + Ff - y_r \end{aligned} \quad (11)$$

where  $x \in \mathcal{R}^n$  is state vector,  $u \in \mathcal{R}^m$  is control,  $i_0 \in \mathcal{R}^h$  is the real value of currents and  $d \in \mathcal{R}^h$  is the current noises. The signal  $f \in \mathcal{R}^q$  represents the incipient sensor fault. It is assumed throughout this paper that  $n \geq p \geq q$ . Matrices  $A$ ,  $B$ ,  $C$ ,  $E$  and  $F$  are known constant with  $C$  being full row rank and  $F$  full column rank.

Let  $x_a := \text{col}(x, f)$ . System (11) and incipient sensor faults (10) can be represented in an augmented form

$$\begin{aligned} \dot{x}_a &= A_a x_a + B_a u + E_a i_0 + E_a d + D_a \xi, \\ e_{yr} &= C_a x_a - y_r \end{aligned} \quad (12)$$

where

$$A_a = \begin{bmatrix} A & \\ & A_f \end{bmatrix} \in \mathcal{R}^{(n+q) \times (n+q)}, \quad B_a = \begin{bmatrix} B_0 \\ 0 \end{bmatrix} \in \mathcal{R}^{(n+q) \times m}, \quad E_a = \begin{bmatrix} B_0 \\ 0 \end{bmatrix} \in \mathcal{R}^{(n+q) \times h},$$

$$D_a = \begin{bmatrix} 0 \\ I_q \end{bmatrix} \in \mathcal{R}^{(n+q) \times q}, \quad C_a = \begin{bmatrix} C & F \end{bmatrix} \in \mathcal{R}^{p \times (n+q)}. \quad \text{Suppose that } F \text{ in (11) has the form}$$

$$F = \begin{bmatrix} 0_{(p-q) \times q} \\ I_q \end{bmatrix}. \quad (13)$$

Then  $\text{rank}(C_a D_a) = q$  and  $\text{rank}(D_a) = q$ , which implies the relative degree of the triple  $(A_a, D_a, C_a)$  is inherently one.

**Assumption 1.** The invariant zeros of the triple  $(A_a, D_a, C_a)$  (if any) lie in the left half plane.

**Assumption 2.** All the incipient fault parameters  $\xi$ ,  $\dot{\xi}$  and disturbance  $d$  satisfy that

$$\xi^T Q_\xi \xi \leq \xi_0, \quad \dot{\xi}^T Q_{\dot{\xi}} \dot{\xi} \leq \xi_1, \quad d^T Q_d d \leq d_0 \quad (14)$$

where the positive definite matrices  $Q_\xi \in \mathcal{R}^{q \times q}$ ,  $Q_{\dot{\xi}} \in \mathcal{R}^{q \times q}$ ,  $Q_d \in \mathcal{R}^{h \times h}$  and the positive constants  $\xi_0, \xi_1, d_0$  are known.

**Remark 2.** Assumption 1 is necessary for the unknown input observer design (see, e.g. [9], [29] and [28]). It has proved in [20] that the unobservable modes of the pair  $(A, C)$  are the invariant zeros of the triple  $(A_a, D_a, C_a)$ . Therefore, in order to check Assumption 1, it only requires to check whether all the unobservable modes of the pair  $(A, C)$  lie in the left-half plane. Assumption 2 means  $\xi$ ,  $\dot{\xi}$  and  $d$  are bounded. Therefore, both the fault signal  $f$ , and its developing rate are assumed to be bounded, which are in consistence with the practical case.  $\nabla$

To reject the bounded exogenous disturbances, the invariant ellipsoid concept is introduced.

**Definition 1.** The ellipsoid

$$\varepsilon(P) = \{x : x^T P x < 1\}, P > 0 \quad (15)$$

with the center in the origin and a radius matrix  $P$ , is said to be an invariant ellipsoid for the systems  $\dot{x} = Ax + D\omega$  with respect to the bounded disturbances  $\omega$

- if  $x(0) \in \varepsilon(P)$ , then  $x(t) \in \varepsilon(P)$  for all  $t \geq 0$ ;
- and if  $x(0) \notin \varepsilon(P)$ , then  $x(t) \rightarrow \varepsilon(P)$  for  $t \rightarrow \infty$ .

From definition 1, it follows that any trajectory of the system starting in the invariant ellipsoid will stay in it for all  $t > 0$ , while a trajectory starting outside of the invariant ellipsoid will converge to this ellipsoid (asymptotically or in finite time).

The tasks of fault detection and isolation (FDI) are to determine the occurrence of a fault in the functional units of the process, and to determine the location and fault type. The fault estimation (FE) is used to estimate the size and behavior of a fault or parameters. In this paper, an optimal adaptive FE is developed to estimate the parameters of incipient sensor faults, and then an optimal fault-tolerant controller is proposed to complete the tracking task, which is able to tolerate the incipient sensor faults.



### III. ADAPTIVE UNKNOWN INPUT OBSERVER DESIGN

In this section, an adaptive unknown input observer will be designed to estimate the system states  $x$  and the unknown inputs  $\xi$  in (12) such that the estimation errors converge to an invariant ellipsoid.

Based on [28], since the relative degree of the triple  $(A_a, D_a, C_a)$  is one, there exists a coordinate transformation for augmented system (12) such that the triple  $(A_a, D_a, C_a)$  in the new coordinates can be described by

$$\left( \begin{bmatrix} A_{a11} & A_{a12} \\ A_{a21} & A_{a22} \end{bmatrix}, \begin{bmatrix} 0_{(n+q-p) \times q} \\ D_{a2} \end{bmatrix}, \begin{bmatrix} 0_{p \times (n+q-p)} & C_{a2} \end{bmatrix} \right), D_{a2} = \begin{bmatrix} 0_{(p-q) \times q} \\ D_{a22} \end{bmatrix} \quad (16)$$

where  $A_{a11} \in \mathcal{R}^{(n+q-p) \times (n+q-p)}$ ,  $C_{a2} \in \mathcal{R}^{p \times p}$  is orthogonal and  $D_{a22} \in \mathcal{R}^{q \times q}$  is nonsingular.

Under Assumption 1, it follows from [30] that there exists a matrix  $L \in \mathcal{R}^{(n+q-p) \times p}$ , described by

$$L = [L_1, 0] \quad (17)$$

with  $L_1 \in \mathcal{R}^{(n+q-p) \times (p-q)}$ , such that  $A_{a11} + LA_{a21}$  is stable.

Denote  $x_a = \text{col}(x_1, x_2)$  with  $x_1 \in \mathcal{R}^{n+q-p}$  and  $x_2 \in \mathcal{R}^p$ . It is assumed without loss of generality, that the system (12) has the form

$$\begin{aligned} \dot{x}_1 &= A_{a11}x_1 + A_{a12}x_2 + B_{a1}u + E_{a1}i_0 + E_{a1}d, \\ \dot{x}_2 &= A_{a21}x_1 + A_{a22}x_2 + B_{a2}u + E_{a2}i_0 + E_{a2}d + D_{a2}\xi, \\ e_{yr} &= C_{a2}x_2 - y_r, \end{aligned} \quad (18)$$

where  $B_{a1}$  and  $B_{a2}$  can be obtained from [30].

Then there exists a linear coordinate transformation  $z = Tx_a$  where

$$T = \begin{bmatrix} I_{n+q-p} & L \\ 0 & C_{a2} \end{bmatrix} \quad (19)$$

with  $L$  given in (17) such that the system (12) can be described by

$$\begin{aligned} \dot{z}_1 &= \hat{A}_{11}z_1 + \hat{A}_{12}z_2 + \hat{B}_1u + \hat{E}_1i_0 + \hat{E}_1d, \\ \dot{z}_2 &= \hat{A}_{21}z_1 + \hat{A}_{22}z_2 + \hat{B}_2u + \hat{E}_2i_0 + \hat{E}_2d + \hat{D}_2\xi, \\ e_{yr} &= z_2 - y_r, \end{aligned} \quad (20)$$

where  $z := \text{col}(z_1, z_2)$  with  $z_1 \in \mathcal{R}^{n+q-p}$  and  $z_2 \in \mathcal{R}^p$ ,  $\hat{A}_{11} = A_{a11} + LA_{a21}$  is stable,  $\hat{A}_{12} = -(A_{a11} + LA_{a21})LC_{a2}^{-1} + (A_{a12} + LA_{a22})C_{a2}^{-1}$ ,  $\hat{A}_{21} = C_{a2}A_{a21}$ ,  $\hat{A}_{22} = C_{a2}(A_{a22} - A_{a21}L)C_{a2}^{-1}$ ,  $\hat{B}_1 = B_{a1} + LB_{a2}$ ,  $\hat{B}_2 = C_{a2}^{-1}B_{a2}$ ,  $\hat{E}_1 = E_{a1} + LE_{a2}$ ,  $\hat{E}_2 = C_{a2}^{-1}E_{a2}$  and  $\hat{D}_2 = C_{a2}^{-1}D_{a2}$ .

It should be pointed out that [28] has constructed the constraint Lyapunov matrix

$$P := \begin{bmatrix} P_1 & P_1 L \\ L^T P_1 & P_2 + L^T P_2 L \end{bmatrix} \quad (21)$$

where  $L$  is given in (17), and

$$(T^{-1})^T P T^{-1} = \begin{bmatrix} P_1 \\ P_0 \end{bmatrix} \quad (22)$$

where  $P_1 \in \mathcal{R}^{(n+q-p) \times (n+q-p)}$  and  $P_0 = C_{a2} P_2 C_{a2}^T \in \mathcal{R}^{p \times p}$ .

For system (20), an adaptive unknown input observer is proposed as

$$\dot{\hat{z}}_1 = \hat{A}_{11} \hat{z}_1 + \hat{A}_{12} \hat{z}_2 + K_1 (z_2 - \hat{z}_2) + \hat{B}_1 u + \hat{E}_1 i_0, \quad (23)$$

$$\dot{\hat{z}}_2 = \hat{A}_{21} \hat{z}_1 + \hat{A}_{22} \hat{z}_2 + K_2 (z_2 - \hat{z}_2) + \hat{B}_2 u + \hat{E}_2 i_0 + \hat{D}_2 \hat{\xi}(t), \quad (24)$$

$$\dot{\hat{\xi}} = \Gamma \hat{D}_2^T P_0 (z_2 - \hat{z}_2) - \sigma \Gamma \hat{\xi}, \quad (25)$$

$$\hat{e}_{yr} = \hat{z}_2 - y_r \quad (26)$$

where  $K_1$  is chosen as  $K_1 = \hat{A}_{12} + G_1$  with  $G_1 \in \mathcal{R}^{(n+q-p) \times p}$ . The matrix  $K_2$  is chosen as  $K_2 = \hat{A}_{22} + G_2$  with  $G_2 \in \mathcal{R}^{p \times p}$ . The gain matrices  $G_1, G_2$ , the constant  $\sigma > 0$  and the weighting matrix  $\Gamma = \Gamma^T > 0$  are determined later. The update law (25) is the proposed adaptive law used to estimate the unknown input  $\xi$ .

Let  $e_1 = z_1 - \hat{z}_1$ ,  $e_y = z_2 - \hat{z}_2$  and  $e_\xi = \xi - \hat{\xi}$ . Then by comparing (20) and (23)-(26), the error dynamical system is given by

$$\begin{aligned} \dot{e}_1 &= \hat{A}_{11} e_1 - G_1 e_y + \hat{E}_1 d, \\ \dot{e}_y &= \hat{A}_{21} e_1 - G_2 e_y + \hat{E}_2 d + \hat{D}_2 e_\xi, \\ \dot{\hat{\xi}} &= \Gamma \hat{D}_2^T P_0 (z_2 - \hat{z}_2) - \sigma \Gamma \hat{\xi}. \end{aligned} \quad (27)$$

Consider the ellipsoid

$$\varepsilon(\mathcal{P}) = \{\text{col}(e_1, e_y, e_\xi) : \text{col}(e_1, e_y, e_\xi)^T \mathcal{P} \text{col}(e_1, e_y, e_\xi) < 1\} \quad (28)$$

where  $\mathcal{P} = \text{diag}\{P_1, P_0, \Gamma^{-1}\} > 0$ . Then the following theorem is ready to be presented.

**Lemma 2.** *Under Assumptions 1 and 2, for certain  $\sigma > 0$  and some  $\alpha > 0$ , the set  $\varepsilon(\mathcal{P})$  is an invariant ellipsoid for error system (27), if there exist SPD matrices  $P_1 \in \mathcal{R}^{(n+q-p) \times (n+q-p)}$ ,*

$P_0 \in \mathcal{R}^{p \times p}$  in (22) and  $\Gamma^{-1} \in \mathcal{R}^{q \times q}$  in (25), and matrices  $Y_1 \in \mathcal{R}^{(n+q-p) \times p}$ ,  $W_1 \in \mathcal{R}^{(n+q-p) \times p}$  and  $W_2 \in \mathcal{R}^{p \times p}$  such that

$$P_0 > 0, P_1 > 0, \Gamma^{-1} > 0, \quad (29)$$

$$\begin{bmatrix} \Theta_{11} + \alpha P_1 & \Theta_{12} & 0 & 0 & 0 & \Theta_{16} \\ * & \Theta_{22} + \alpha P_0 & 0 & 0 & 0 & \Theta_{26} \\ * & * & -2\sigma I + \alpha \Gamma^{-1} & \sigma I & \Gamma^{-1} & 0 \\ * & * & * & -\frac{\alpha}{\gamma} Q_\xi & 0 & 0 \\ * & * & * & * & -\frac{\alpha}{\gamma} Q_\xi & 0 \\ * & * & * & * & * & -\frac{\alpha}{\gamma} Q_d \end{bmatrix} < 0 \quad (30)$$

where  $\Theta_{11} = He(P_1 A_{a11} + Y_1 A_{a21})$ ,  $\Theta_{12} = -W_1 + (C_{a2} A_{a21})^T P_0$ ,  $\Theta_{16} = P_1 E_{a1} + Y_1 E_{a2}$ ,  $\Theta_{22} = -He(W_2)$ ,  $\Theta_{26} = P_0 C_{a2}^{-1} E_{a2}$  and  $\gamma = \max\{\xi_0, \xi_1, d_0\}$ . Then, the gain matrices  $L = P_1^{-1} Y_1$ ,  $G_1 = P_1^{-1} W_1$  and  $G_2 = P_0^{-1} W_2$ .

*Proof:* From (22), the function  $V = e_1^T P_1 e_1 + e_y^T P_0 e_y + e_\xi^T \Gamma^{-1} e_\xi$  can be chosen as the Lyapunov candidate function. Note that  $\dot{e}_\xi = \dot{\xi} - \hat{\xi}$ . Then the time derivative of  $V$  along the trajectory of system (27) is

$$\begin{aligned} \dot{V} &= e_1^T (P_1 \hat{A}_{11} + \hat{A}_{11}^T P_1) e_1 - 2e_1^T P_1 G_1 e_y + 2e_1^T P_1 \hat{E}_1 d \\ &\quad + 2e_y^T P_0 \hat{A}_{21} e_1 - e_y^T (P_0 G_2 + G_2^T P_0) e_y + 2e_y^T P_0 \hat{D}_2 e_\xi + 2e_y^T P_0 \hat{E}_2 d \\ &\quad - 2e_\xi^T \hat{D}_2^T P_0 e_y - 2\sigma e_\xi^T e_\xi + 2\sigma e_\xi^T \xi + 2e_\xi^T \Gamma^{-1} \dot{\xi} \\ &= \begin{bmatrix} e_1 \\ e_y \\ e_\xi \\ \xi \\ \dot{\xi} \\ d \end{bmatrix}^T \begin{bmatrix} \Xi_{11} & \Xi_{12} & 0 & 0 & 0 & \Xi_{16} \\ * & \Xi_{22} & 0 & 0 & 0 & \Xi_{26} \\ * & * & -2\sigma I & \sigma I & \Gamma^{-1} & 0 \\ * & * & * & 0 & 0 & 0 \\ * & * & * & * & 0 & 0 \\ * & * & * & * & * & 0 \end{bmatrix} \begin{bmatrix} e_1 \\ e_y \\ e_\xi \\ \xi \\ \dot{\xi} \\ d \end{bmatrix} \end{aligned} \quad (31)$$

where  $\Xi_{11} = He(P_1 \hat{A}_{11})$ ,  $\Xi_{12} = -P_1 G_1 + \hat{A}_{21}^T P_0$ ,  $\Xi_{16} = P_1 \hat{E}_1$ ,  $\Xi_{22} = -He(P_0 G_2)$ ,  $\Xi_{26} = P_0 \hat{E}_2$ .

Obviously, the  $\varepsilon(\mathcal{P})$  is an invariant ellipsoid if and only if  $\dot{V} < 0$ , for any  $(e_1, e_y, e_\xi)$  satisfying  $(e_1, e_y, e_\xi)^T \mathcal{P}(e_1, e_y, e_\xi) \geq 1$  and for  $\text{col}(\xi, \dot{\xi}, d)$  satisfying Assumption 2.

From Assumption 2,  $\xi$ ,  $\dot{\xi}$  and  $d$  satisfy

$$\frac{1}{\gamma} \begin{bmatrix} e_1 \\ e_y \\ e_\xi \\ \xi \\ \dot{\xi} \\ d \end{bmatrix}^T \begin{bmatrix} 0 & 0 & 0 & 0 & 0 & 0 \\ * & 0 & 0 & 0 & 0 & 0 \\ * & * & 0 & 0 & 0 & 0 \\ * & * & * & Q_\xi & 0 & 0 \\ * & * & * & * & Q_{\dot{\xi}} & 0 \\ * & * & * & * & * & Q_d \end{bmatrix} \begin{bmatrix} e_1 \\ e_y \\ e_\xi \\ \xi \\ \dot{\xi} \\ d \end{bmatrix} \leq 1. \quad (32)$$

Define

$$A_0 := \begin{bmatrix} \Xi_{11} & \Xi_{12} & 0 & 0 & 0 & \Xi_{16} \\ * & \Xi_{22} & 0 & 0 & 0 & \Xi_{26} \\ * & * & -2\sigma I & \sigma I & \Gamma^{-1} & 0 \\ * & * & * & 0 & 0 & 0 \\ * & * & * & * & 0 & 0 \\ * & * & * & * & * & 0 \end{bmatrix}, \quad A_1 := \begin{bmatrix} -P_1 & 0 & 0 & 0 & 0 & 0 \\ * & -P_0 & 0 & 0 & 0 & 0 \\ * & * & -\Gamma^{-1} & 0 & 0 & 0 \\ * & * & * & 0 & 0 & 0 \\ * & * & * & * & 0 & 0 \\ * & * & * & * & * & 0 \end{bmatrix},$$

$$A_2 := \begin{bmatrix} 0 & 0 & 0 & 0 & 0 & 0 \\ * & 0 & 0 & 0 & 0 & 0 \\ * & * & 0 & 0 & 0 & 0 \\ * & * & * & \frac{1}{\gamma} Q_\xi & 0 & 0 \\ * & * & * & * & \frac{1}{\gamma} Q_{\dot{\xi}} & 0 \\ * & * & * & * & * & \frac{1}{\gamma} Q_d \end{bmatrix}$$

and  $f_i(\zeta) := \zeta^T A_i \zeta$  where  $\zeta = \text{col}(e_1, e_y, e_\xi, \xi, \dot{\xi}, d)$ .

According to the S-procedure, the inequalities  $f_1(\zeta) \leq -1$  and  $f_2(\zeta) \leq 1$  imply  $f_0(\zeta) < 0$  if and only if there exist  $\tau_1, \tau_2 \geq 0$  such that  $A_0 < \tau_1 A_1 + \tau_2 A_2$  and  $0 \geq -\tau_1 + \tau_2$ . Since the minimal ellipsoid is concerned,  $\tau_2 = \tau_{2max} = \tau_1$ .

Hence, by letting  $\tau_1 = \alpha$ , the result follows. ■

**Remark 3.** In fact, if the adaptive law in (27) is constructed as  $\dot{\hat{\xi}} = -\Gamma \hat{D}_2^T P_2 (z_2 - \hat{z}_2)$ , then  $e_1$  and  $e_y$  can be constructed accurately in steady stage case. However, the unknown inputs  $\xi$  cannot be estimated because of “parameter drift”. The  $\sigma$ -modification adaptive law in (27) is used to reject the “parameter drift”.  $\nabla$

It follows from Lemma 2 that the estimation error  $(e_1, e_y, e_\xi)$  converges to an invariant ellipsoid. From a qualitative point of view, a “big” radius matrix  $\mathcal{P}$  provides a “small” ellipsoid. Hence, an optimal problem will be proposed to minimize the estimation error to reconstruct states more accurately.

Given the ellipsoid

$$\varepsilon(\mathcal{Q}^{-1}) = \{\text{col}(e_1, e_y, e_\xi) : \text{col}(e_1, e_y, e_\xi)^T \mathcal{Q}^{-1} \text{col}(e_1, e_y, e_\xi) < 1\}, \quad \mathcal{Q} \in \mathcal{R}^{(n+q) \times (n+q)} > 0. \quad (33)$$

The following results are obtained.

**Theorem 1.** *Under Assumptions 1 and 2, for certain  $\sigma > 0$  and some  $\alpha > 0$ , the ellipsoid  $\varepsilon(\mathcal{Q}^{-1})$  is the minimal invariant ellipsoid with respect to  $\text{col}(e_1, e_y, e_\xi)$ , if there exist SPD matrices  $P_1, P_0, \Gamma^{-1}$  and  $\mathcal{Q} \in \mathcal{R}^{(n+q) \times (n+q)}$ , matrices  $Y_1, W_1$  and  $W_2$  such that*

$$\text{tr}(\mathcal{Q}) \rightarrow \min \quad (34)$$

subject to (29), (30) and

$$\begin{bmatrix} \mathcal{P} & I \\ I & \mathcal{Q} \end{bmatrix} \geq 0, \quad \mathcal{Q} > 0. \quad (35)$$

*Proof:* From Lemma 2, the set  $\varepsilon(\mathcal{P})$  is an invariant ellipsoid with respect to  $\text{col}(e_1, e_y, e_\xi)$ . Hence, if  $\mathcal{Q}$  satisfies

$$\mathcal{Q}^{-1} \leq \mathcal{P}, \quad (36)$$

then  $\varepsilon(\mathcal{Q}^{-1})$  is an invariant ellipsoid with respect to  $\text{col}(e_1, e_y, e_\xi)$ . Finally, the Schur component provides the inequality (35).  $\blacksquare$

It should be pointed out that  $\varepsilon(\mathcal{P})$  and  $\varepsilon(\mathcal{Q}^{-1})$  are both invariant ellipsoid with respect to  $\text{col}(e_1, e_y, e_\xi)$  and  $\varepsilon(\mathcal{P}) \subset \varepsilon(\mathcal{Q}^{-1})$ .

#### IV. INCIPIENT FAULT ESTIMATION

In this section, the incipient fault will be estimated. From  $x_a = \text{col}(x, f)$ , it follows that

$$f = C_f x_a \quad (37)$$

where  $C_f = [0, I_q]$ , and

$$f = C_f T^{-1} z \quad (38)$$

where  $T$  is given in (19). Further partition  $C_{a2}^{-1}$  in (16) as

$$C_{a2}^{-1} = \begin{bmatrix} \bar{C}_{a21} \\ \bar{C}_{a22} \end{bmatrix} \quad (39)$$

where  $\bar{C}_{a21} \in \mathcal{R}^{(p-q) \times p}$  and  $\bar{C}_{a22} \in \mathcal{R}^{q \times p}$ . Then the incipient fault  $f$  is constructed as  $f = \bar{C}_{a22} z_2$ . Based on the proposed observer (23)-(26), it follows that  $\hat{f} = \bar{C}_{a22} C_{z_2} \text{col}(z, \xi)$  and the estimation error  $e_f$  is expressed by

$$e_f = \bar{C}_{a22} C_{z_2} \text{col}(e_1, e_y, e_\xi) \quad (40)$$

where  $C_{z_2} = [0_{p \times (n+q-p)}, I_p, 0_{p \times q}]$ .

Define an ellipsoid as

$$\varepsilon(Z^{-1}) = \{e_f : e_f^T Z^{-1} e_f < 1\} \quad (41)$$

where  $Z \in R^{q \times q}$ ,  $Z > 0$ .

The objective here is to choose appropriate gains  $\Gamma$ ,  $L$ ,  $G_1$  and  $G_2$  to minimize the invariant ellipsoid  $\varepsilon(Z^{-1})$  to further minimize  $e_f$ . The following theorem is ready to be presented.

**Theorem 2.** *Under Assumptions 1 and 2, for certain  $\sigma > 0$  and some  $\alpha > 0$ , the ellipsoid  $\varepsilon(Z)$  is the minimal invariant ellipsoid with respect to  $e_f$  given in (40), if there exist SPD matrices  $P_1$ ,  $P_0$ ,  $\Gamma^{-1}$  and  $Z \in R^{q \times q}$ , and matrices  $Y_1$ ,  $W_1$ ,  $W_2$  such that*

$$\text{tr}(Z) \rightarrow \min \quad (42)$$

subject to (29), (30) and

$$\begin{bmatrix} \mathcal{P} & (\bar{C}_{a22} C_{z_2})^T \\ \bar{C}_{a22} C_{z_2} & Z \end{bmatrix} \geq 0, \quad Z > 0. \quad (43)$$

*Proof:* The ellipsoid  $\varepsilon(Z^{-1})$  defined in (41) can be presented by

$$e_f^T Z^{-1} e_f = (\text{col}(e_1, e_y, e_\xi))^T (\bar{C}_{a22} C_{z_2})^T Z^{-1} \bar{C}_{a22} C_{z_2} \text{col}(e_1, e_y, e_\xi) < 1. \quad (44)$$

From Lemma 1,  $\varepsilon(\mathcal{P})$  is an invariant ellipsoid with respect to  $\text{col}(e_1, e_y, e_\xi)$ . Thus, if  $Z$  satisfies

$$(\bar{C}_{a22} C_{z_2})^T Z^{-1} \bar{C}_{a22} C_{z_2} \leq \mathcal{P}, \quad (45)$$

then  $\varepsilon(Z^{-1})$  is an invariant ellipsoid with respect to  $e_f$ . Finally, the Schur component provides inequality (43). ■

## V. FAULT-TOLERANT CONTROLLER DESIGN

In this section, an output feedback fault-tolerant controller will be designed based on the observer (23)-(26), which would ensure that the voltage tracking errors converge to the minimal invariant ellipsoid.

Let  $\hat{\omega} = \text{col}(\hat{\xi}, y_r, i_0) \in \mathcal{R}^{q+p+h}$  be the estimation of  $\omega = \text{col}(\xi, y_r, i_0)$ . Then the tracking error  $e_{yr}$  in (12) can be written as

$$e_{yr} = z_2 - y_r = C_0 z + D_0 \omega = C_0 z + D_0 \hat{\omega} \quad (46)$$

where  $C_0 = [0_{p \times (n+q-p)}, I_p]$  and  $D_0 = [0_{p \times q}, -I_p, 0_{p \times h}]$ .

Note that  $e_y = y - \hat{y} = z_2 - \hat{z}_2 = e_{yr} - \hat{e}_{yr}$ . Based on the designed observer (23)-(26), the regulator is designed as

$$\begin{aligned} \dot{\hat{z}} &= (\hat{A} - H_1 C_0) \hat{z} - H_1 D_0 \hat{\omega} + N \hat{\omega} + \hat{B} u + H_1 e_{yr}, \\ \dot{\hat{\xi}} &= -\Gamma \hat{D}_2^T P_0 C_0 \hat{z} - \sigma \Gamma \hat{\xi} - \Gamma \hat{D}_2^T P_0 D_0 \hat{\omega} + \Gamma \hat{D}_2^T P_0 e_{yr}, \\ \dot{y}_r &= M_{yr} y_r, \quad \dot{i}_0 = M_{i_0} i_0 \end{aligned} \quad (47)$$

where  $M_{i_0}$  and  $M_{yr}$  are matrices dependent on the  $i_0$  and  $y_r$ , and

$$\hat{A} = \begin{bmatrix} \hat{A}_{11} & \hat{A}_{12} \\ \hat{A}_{21} & \hat{A}_{22} \end{bmatrix}, \quad \hat{B} = \begin{bmatrix} \hat{B}_1 \\ \hat{B}_2 \end{bmatrix}, \quad H_1 = \begin{bmatrix} -K_1 \\ -K_2 \end{bmatrix}, \quad N = [\hat{D}, 0, \hat{E}]$$

with

$$\hat{D} = \begin{bmatrix} 0 \\ \hat{D}_2 \end{bmatrix}, \quad \hat{E} = \begin{bmatrix} \hat{E}_1 \\ \hat{E}_2 \end{bmatrix}.$$

Let  $\hat{z}_c = \text{col}(\hat{z}, \hat{\omega})$ . Then it follows from (47) that

$$\dot{\hat{z}}_c = A_{c0} \hat{z}_c + B_c u + H e_{yr} \quad (48)$$

where

$$A_{c0} = \begin{bmatrix} A_{c011} & A_{c012} \\ A_{c021} & A_{c022} \end{bmatrix}, \quad B_c = \begin{bmatrix} B_{c1} \\ B_{c2} \end{bmatrix}, \quad H = \begin{bmatrix} H_1 \\ H_2 \end{bmatrix} \quad \text{and} \quad M = \begin{bmatrix} -\sigma \Gamma & 0 & 0 \\ 0 & M_{yr} & 0 \\ 0 & 0 & M_{i_0} \end{bmatrix}$$

with  $H_2 = \text{col}(\Gamma \hat{D}_2^T P_2, 0, 0)$ ,  $A_{c011} = \hat{A} - H_1 C_0$ ,  $A_{c012} = N - H_1 D_0$ ,  $A_{c021} = -H_2 C_0$ ,  $A_{c022} = M - H_2 D_0$ ,  $B_{c1} = \hat{B}$ ,  $B_{c2} = 0$ .

Let  $F_c = [F_u, F_\omega]$  with  $F_u \in \mathcal{R}^{m \times n}$  and  $F_\omega \in \mathcal{R}^{m \times (q+p+h)}$ . The fault-tolerant controller is designed as

$$u = -F_u \hat{z} - F_\omega \hat{\omega} = -F_c \hat{z}_c \quad (49)$$

where  $F_u$  is the related to stabilization of the original system (20) and  $F_\omega$  is the disturbance compensation gain. Then it follows that the output regulator (48) is described by

$$\dot{\hat{z}}_c = A_c \hat{z}_c + H e_{yr} \quad (50)$$

where

$$A_c = \begin{bmatrix} \hat{A} - H_1 C_0 - \hat{B} F_u & N - H_1 D_0 - \hat{B} F_\omega \\ -H_2 C_0 & M - H_2 D_0 \end{bmatrix}.$$

Denote  $e_z = z - \hat{z}$ ,  $e_\omega = \omega - \hat{\omega}$ . Substituting the output regulator (50) and controller (49) into system (20) yields the closed-loop system

$$\underbrace{\begin{bmatrix} \dot{z} \\ \dot{z}_c \end{bmatrix}}_{\dot{z}_L} = \underbrace{\begin{bmatrix} \hat{A} - \hat{B} F_u & 0 \\ H C_0 & A_c \end{bmatrix}}_{A_L} \underbrace{\begin{bmatrix} z \\ z_c \end{bmatrix}}_{z_L} + \underbrace{\begin{bmatrix} N - \hat{B} F_\omega \\ H D_0 \end{bmatrix}}_{N_L} \omega + \underbrace{\begin{bmatrix} \hat{B} F_c \\ 0 \end{bmatrix}}_{R_L} \underbrace{\begin{bmatrix} e_z \\ e_\omega \end{bmatrix}}_{e_L} + \underbrace{\begin{bmatrix} \hat{E} \\ 0 \end{bmatrix}}_{E_L} \underbrace{\begin{bmatrix} d \\ 0 \end{bmatrix}}_{d_L}, \quad (51)$$

$$e_{yr} = C_L z_L + D_L \omega \quad (52)$$

where  $e_z = z - \hat{z}$ ,  $e_\omega = \omega - \hat{\omega}$ ,  $C_L = [C_0, 0]$  and  $D_L = D_0$ . It should be noted that  $C_L D_L^T = 0$ .

Define the ellipsoid

$$\varepsilon(\mathcal{R}^{-1}) = \{e_{yr} : e_{yr}^T \mathcal{R}^{-1} e_{yr} < 1\}, \quad \mathcal{R} \in \mathcal{R}^{q \times q}, \quad \mathcal{R} > 0. \quad (53)$$

Then the following theorem is ready to be presented.

**Theorem 3.** *For the closed-loop systems (51) and (52), the ellipsoid  $\varepsilon(\mathcal{R}^{-1})$  given in (53) is the minimal invariant ellipsoid with respect to the tracking error  $e_{yr}$  if there exist matrices  $J$  and  $Q$  such that*

$$\hat{A}J - JM + \hat{B}Q = N, \quad (54)$$

$$A_c S - SM = 0, \quad (55)$$

$$C_0 J = D_0, \quad (56)$$



and for any  $\alpha > 0$ ,  $\mu > 0$  and  $P_{z\omega} = P_{z\omega}^T > 0$  satisfying that

$$\begin{bmatrix} I \\ J^T \end{bmatrix} P_{z\omega} \begin{bmatrix} I & J \end{bmatrix} \leq \begin{bmatrix} \mathcal{P} & \\ & Q_\omega \end{bmatrix}, \quad (57)$$

there exist SPD matrices  $X \in \mathcal{R}^{(n+q) \times (n+q)}$ ,  $\mathcal{R} \in \mathcal{R}^{p \times p}$ , and matrix  $Y_u \in \mathcal{R}^{m \times (n+q)}$  such that

$$\text{tr}(\mathcal{R}) \rightarrow \min \quad (58)$$

subject to

$$(P_{z\omega})^{-1} \leq X, \quad (59)$$

$$\begin{bmatrix} X & Y_u^T \\ * & \mu^2 I \end{bmatrix} \geq 0, \quad (60)$$

$$\begin{bmatrix} \hat{A}X + X\hat{A}^T - \hat{B}Y_u - Y_u^T\hat{B}^T + \alpha X & \hat{B} & \hat{B}Q & \hat{E} \\ * & -\frac{\alpha}{\mu^2}I & 0 & 0 \\ * & * & -\alpha Q_\omega & 0 \\ * & * & * & -\alpha Q_d \end{bmatrix} \leq 0, \quad (61)$$

$$\begin{bmatrix} Q_\omega & D_0^T \\ & \mathcal{R} \end{bmatrix} \geq 0, \quad \begin{bmatrix} X & XC_0^T \\ * & \mathcal{R} \end{bmatrix} \geq 0, \quad \mathcal{R} > 0. \quad (62)$$

where  $S = [J^T, -I]^T$ ,  $Q = -F_c S$ ,  $\mathcal{P}$  is determined by Theorem 1 and  $Q_d$  can be obtained through Assumption 2,  $Q_\omega$  is determined later. Then  $P_L = X^{-1}$ ,  $F_u = Y_u P_L$  and  $F_\omega = Q + F_u J$ .

*Proof:* There are four disturbances in system (51):  $N_L\omega$ ,  $R_L e_L$ ,  $E_L d_L$  and  $D_L\omega$ . Based on linear superposition property, the effects of the disturbances on  $e_{yr}$  can be divided as  $e_{yr} = e_{yr1} + e_{yr2}$  where  $e_{yr1} = C_L z_{L1} + D_L\omega$  and  $e_{yr2} = C_L z_{L2}$  with  $z_L = z_{L1} + z_{L2}$ ,  $z_{L1}$  and  $z_{L2}$  will be given later.

a) : In the presence of  $N_L\omega$  and  $D_L\omega$ , the equations (51) and (52) are written as

$$\underbrace{\begin{bmatrix} \dot{z} \\ \dot{z}_c \end{bmatrix}}_{z_{L1}} = \underbrace{\begin{bmatrix} \hat{A} - \hat{B}F_u & 0 \\ HC_0 & A_c \end{bmatrix}}_{A_L} \underbrace{\begin{bmatrix} z \\ z_c \end{bmatrix}}_{z_{L1}} + \underbrace{\begin{bmatrix} N - \hat{B}F_\omega \\ HD_0 \end{bmatrix}}_{N_L} \omega, \quad (63)$$

$$e_{yr1} = C_L z_{L1} + D_L\omega.$$

Let  $W = [J^T, S^T]^T$ . Then it follows that

$$C_L W = \begin{bmatrix} C_0 & 0 \end{bmatrix} \begin{bmatrix} J \\ S \end{bmatrix} = C_0 J = D_0$$

and

$$A_L W - W M = \begin{bmatrix} \hat{A} - \hat{B}F_u & 0 \\ HC_0 & A_c \end{bmatrix} \begin{bmatrix} J \\ S \end{bmatrix} - \begin{bmatrix} J \\ S \end{bmatrix} M = \begin{bmatrix} \hat{A}J - \hat{B}F_u J - JM \\ HC_0 J + A_c S - SM \end{bmatrix} = N_L.$$

Hence, based on Lemma 1.4 in [24], if  $F_u$  is designed such that  $\hat{A} - \hat{B}F_u$  is Hurwitz and  $F_\omega = Q + F_u J$ , then in the presence of  $N_L \omega$  and  $D_L \omega$ ,  $e_{yr1} = 0$ .

b) : In the presence of  $R_L e_L$  and  $E_L d_L$ , the tracking error  $e_{yr2}$  depends entirely on  $z$  which can be obtained from (51) and expressed by

$$\dot{z} = (\hat{A} - \hat{B}F_u) z + \hat{B}F_u e_z + \hat{B}F_\omega e_\omega + \hat{E}d, \quad (64)$$

$$e_{yr2} = C_0 z \quad (65)$$

where  $C_0$  is given in (46). From  $F_\omega = F_u J + Q$ , the equation (64) can be written as

$$\dot{z} = (\hat{A} - \hat{B}F_u) z + \hat{B}F_u e_{z\omega} + \hat{B}Q e_\omega + \hat{E}d. \quad (66)$$

where  $e_{z\omega} = \begin{bmatrix} I & J \end{bmatrix} \begin{bmatrix} e_z \\ e_\omega \end{bmatrix}$ .

In fact, from (47),  $e_\omega = [e_\xi^T, 0_{p+h}]^T$ . According to the invariant ellipsoid  $\varepsilon(\mathcal{P})$  in Theorem 1, the radius matrix of the invariant ellipsoid with respect to  $e_\omega$  is expressed by

$$Q_\omega = \begin{bmatrix} \Gamma^{-1} & \\ & \Gamma_{+\infty} \end{bmatrix} \quad (67)$$

where  $\Gamma_{+\infty}$  is a diagonal matrix with appropriate dimension and its eigenvalues tend to  $+\infty$ . Also, the radius matrix is expressed by  $\text{diag}\{\mathcal{P}, Q_\omega\}$  of  $\text{col}(e_z, e_\omega)$ . Then it follows from (57) and (66) that

$$\begin{bmatrix} e_z^T & e_\omega^T \end{bmatrix} \begin{bmatrix} I \\ J^T \end{bmatrix} P_{z\omega} \begin{bmatrix} I & J \end{bmatrix} \begin{bmatrix} e_z \\ e_\omega \end{bmatrix} \leq \begin{bmatrix} e_z^T & e_\omega^T \end{bmatrix} \begin{bmatrix} \mathcal{P} & \\ & Q_\omega \end{bmatrix} \begin{bmatrix} e_z \\ e_\omega \end{bmatrix} < 1. \quad (68)$$

Based on [31], the control input  $F_u z$  is constrained by  $\|F_u z\| \leq \mu^2$  if

$$z^T F_u^T F_u z \leq \mu^2, \quad \forall z : z^T P_L z \leq 1, \quad (69)$$

which holds if and only if (60) holds. It follows from (59) that  $P_{z\omega} \geq P_L$ . Thus, it yields that

$$e_{z\omega}^T F_u^T F_u e_{z\omega} \leq \mu^2, \quad \forall e_{z\omega} : e_{z\omega}^T P_{z\omega} e_{z\omega} \leq 1, P_{z\omega} \geq P_L. \quad (70)$$

Therefore, the inequality (59) and (60) can guarantee that the control input  $F_u z$  and disturbance  $F_u e_{z\omega}$  are bounded. Based on [31] and [32], it can be inferred that the solution of the optimization problem (58) subject to (59)- (61) provides a minimal invariant ellipsoid  $\varepsilon(\mathcal{R}^{-1})$  of  $e_{yr2}$ .

Combining V-0a and V-0b, it infers that  $e_{yr}$  will converge to the minimal invariant ellipsoid  $\varepsilon(\mathcal{R}^{-1})$ .

Hence, the result follows. ■

**Remark 4.** In (51), the undesired term  $R_L e_L$  comes from the estimation error  $\text{col}(e_1, e_y, e_\xi)$  of the designed observer (23)-(26) and the estimation error  $\text{col}(e_1, e_y, e_\xi)$  is guaranteed to converge to the minimal invariant ellipsoid  $\varepsilon(\mathcal{Q}^{-1})$ . In the presence of  $R_L e_L$ , the parameters  $F_u$  and  $F_\omega$  in Theorem 3 are optimized such that the tracking errors converge to the minimal invariant ellipsoid  $\varepsilon(\mathcal{R}^{-1})$ . ▽

## VI. SIMULATION

To verify the effectiveness of the designed adaptive unknown input observer and fault-tolerant controller for inverter device used in traction system, simulation one the case that only one incipient sensor fault occurs, is considered first and then the case that two incipient sensor faults occurs simultaneously, follows. The practical parameters of the three-phase PWM inverter in CRH2 from CRRC ZHUZHOU INSTITUTE CO., LTD are provided in the following table.

TABLE I  
PARAMETERS OF THE INVERTER IN CRH2.

Parameter	Value	Unit
$r$	0.144	$\Omega$
$L_f$	$1.417 \times 10^{-3}$	$H$
$C_f$	$6000 \times 10^{-6}$	$F$
$V_{dc}$	3600	$V$
$\omega_0$	314	$rad/s$

### A. One Incipient fault on $v_{oq}$ voltage sensor

When only one incipient fault occurs in the  $v_{oq}$  voltage sensor, the fault distribution matrix is described by  $F = [0, 1]^T$ . As in [21], the incipient sensor fault considered here is assumed to be generated by  $\dot{f} = -100f + \xi$ ,  $f(0) = 0$  where

$$\xi = \begin{cases} 0, & 0 \leq t < 1s, \\ 2000 \sin(3t), & 1s \leq t. \end{cases} \quad (71)$$

The bounded noise is given by

$$d = \begin{bmatrix} 1.5 \sin(10t) \\ 2.0 \sin(10t) \end{bmatrix}. \quad (72)$$

Thus, from (71) and (72),  $Q_\xi$ ,  $Q_{\dot{\xi}}$ ,  $Q_d$ ,  $\xi_0$ ,  $\xi_1$  and  $d_0$  in Assumption 2 can be obtained, and the augmented system can be established as (12). It can be verified that the augmented system satisfies Assumption 1. Let  $\sigma = 0.1$  and  $\alpha = 0.5$  in Theorem 1. It is calculated that the optimal value  $\min\{\text{trace}(\mathcal{Q})\} = 2243.783328$ . Furthermore, the designed parameters in the proposed observer (23)-(26) are given by

$$\Gamma = 489.1435, \quad P_1 = \begin{bmatrix} 0.2006 & -0.0010 & -0.0584 \\ -0.0010 & 0.2265 & -0.0175 \\ -0.0584 & -0.0175 & 0.0844 \end{bmatrix}, \quad P_0 = \begin{bmatrix} 1.0575 & -0.0003 \\ -0.0003 & 1.0579 \end{bmatrix}$$

$$L = \begin{bmatrix} -0.4180 & 0 \\ -0.1691 & 0 \\ -2.1364 & 0 \end{bmatrix}, \quad G_1 = \begin{bmatrix} -13.0 & -267.4 \\ 5.7 & 706.3 \\ -57.5 & -6978.0 \end{bmatrix} \quad \text{and} \quad G_2 = \begin{bmatrix} 6387.8 & -442.4 \\ -442.4 & 6291.3 \end{bmatrix}.$$

Since only 3D curve can be plotted by Matlab toolbox, the output estimation error  $e_y$  and unknown input estimation error  $e_\xi$  are selected to be shown in Fig. 3.

It can be seen from Fig. 3 that in the presence of disturbances (72), the estimation error  $\text{col}(e_y, e_\xi)$  is bounded and converges to the invariant ellipsoid  $\varepsilon(\mathcal{Q}^{-1})$ .

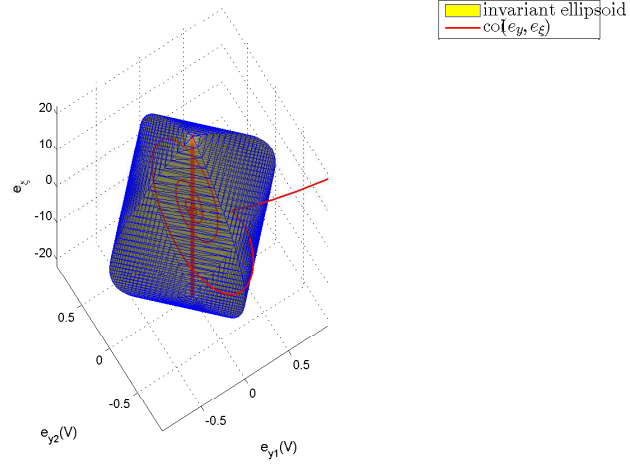

Fig. 3. Invariant ellipsoid  $\varepsilon(\mathcal{Q}^{-1})$  and estimation error  $\text{col}(e_y, e_\xi)$ .

With the calculated observer parameters, the matrices  $J$  and  $Q$  are calculated as

$$J = \begin{bmatrix} -0.1033 & 101.8857 & 5.2779 & -1.0000 & 0.0000 \\ -0.0057 & 6.3047 & 0.0000 & 0 & -1.0000 \\ -0.0277 & 27.3004 & 1.4142 & 0.0000 & 0.0000 \\ 0 & -1.0000 & 0 & 0.0000 & 0 \\ 0 & -0.0000 & -1.0000 & 0 & 0 \end{bmatrix},$$

$$Q = \begin{bmatrix} 0.0000 & -0.0014 & -0.0002 & 0.0000 & -0.0003 \\ 0.0000 & -0.0304 & -0.0015 & 0.0003 & 0.0000 \end{bmatrix}.$$

Let  $\alpha = 53$ ,  $\mu = 10$  and

$$P_{z\omega} = \begin{bmatrix} 0.0833 & -0.0013 & -0.0252 & 0.0000 & 0.0000 \\ -0.0013 & 0.1132 & -0.0086 & 0.0000 & -0.0000 \\ -0.0252 & -0.0086 & 0.0413 & -0.0000 & -0.0000 \\ 0.0000 & 0.0000 & -0.0000 & 0.5288 & -0.0001 \\ 0.0000 & -0.0000 & -0.0000 & -0.0001 & 0.5290 \end{bmatrix}.$$

Then the fault-tolerant controller parameters are calculated based on Theorem 3 as follows

$$F_u = \begin{bmatrix} 0.0048 & -0.0027 & -0.0166 & 0.9079 & -0.8161 \\ -0.0013 & 0.0029 & 0.0027 & -0.4232 & 0.4727 \\ -0.0000 & -0.8885 & 0.8181 & -0.0048 & 0.0030 \\ 0.0000 & 0.4087 & -0.4744 & 0.0010 & -0.0029 \end{bmatrix},$$

$$F_\omega = \begin{bmatrix} 0.0000 & -0.8885 & 0.8181 & -0.0048 & 0.0030 \\ 0.0000 & 0.4087 & -0.4744 & 0.0010 & -0.0029 \end{bmatrix}.$$

The time responses are shown in Figs. 4 and 5. It can be seen from Figs. 4 and 5 that even

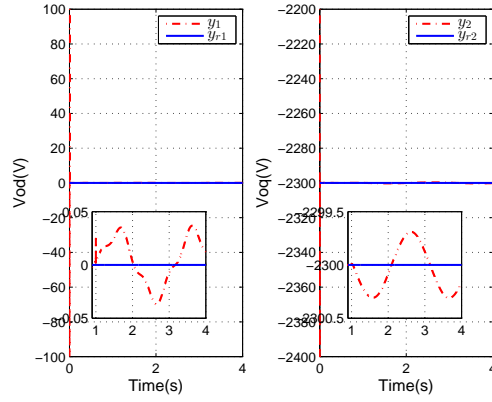

Fig. 4. Time response of the output voltages  $v_{od}$  and  $v_{oq}$ .

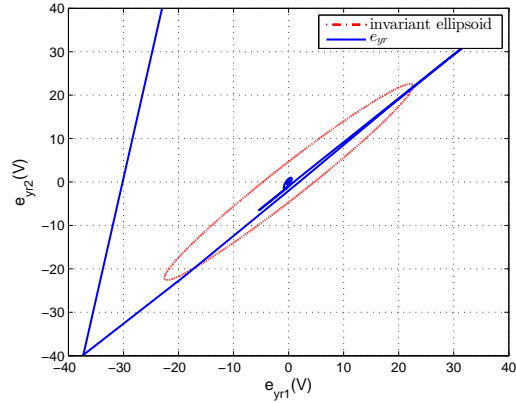

Fig. 5. Invariant ellipsoid  $\varepsilon(\mathcal{R}^{-1})$  and the voltage tracking error  $e_{yr} = \text{col}(e_{yr1}, e_{yr2})$ .

in the presence of disturbances and the incipient  $v_{oq}$  voltage sensor fault, the output voltages of the inverter track the given reference signals with the voltage errors converging to the invariant ellipsoid  $\varepsilon(\mathcal{R}^{-1})$ .

On the other hand, to estimate fault signals more accurately, another unknown input observer is designed based on Theorem 2. By direct calculation the optimal value,  $\min\{\text{trace}(Z)\} = 997.237035$ . The actual incipient sensor fault signal (blue and dot line) and its estimation (red an solid line) are given in Fig. 6, and the fault estimation error is given in Fig. 7. It can be seen

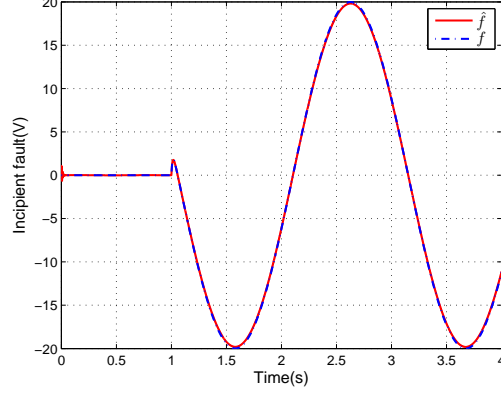

Fig. 6. Time response of the fault estimation curve of  $\hat{f}$  and actual fault curve  $f$ .

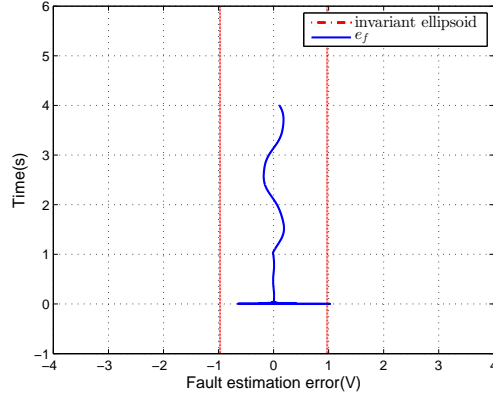

Fig. 7. Invariant ellipsoid  $\varepsilon(Z^{-1})$  and  $v_{oq}$  incipient sensor fault estimation error  $e_f$ .

from Figs. 6 and 7 that the fault estimation error  $e_f$  also converges to the invariant ellipsoid  $\varepsilon(Z^{-1})$ .

The simulation of a single incipient fault occurring on  $v_{od}$  voltage sensor is similar to the case that single incipient fault occurs on  $v_{oq}$  voltage sensor, which is omitted here. The next part will provide simulation for the case when two incipient faults occur on  $v_{oq}$  and  $v_{od}$  voltage sensors simultaneously.

### B. Two incipient faults on $v_{oq}$ and $v_{od}$ voltage sensors simultaneously

When two incipient faults occur on the  $v_{od}$  and  $v_{oq}$  voltage sensors simultaneously, the fault distribution matrix  $F$  is described by

$$F = \begin{bmatrix} 1 & 0 \\ 0 & 1 \end{bmatrix}. \quad (73)$$

The incipient sensor faults are assumed to be generated by

$$\dot{f} = \begin{bmatrix} -100 & \\ & 20 \quad -100 \end{bmatrix} f + \begin{bmatrix} \xi_1 \\ \xi_2 \end{bmatrix}, f(0) = 0 \quad (74)$$

where

$$\xi_1 = \begin{cases} 0, & 0 \leq t < 1s, \\ 2000 \sin(3t), & 1s \leq t, \end{cases} \quad \xi_2 = \begin{cases} 0, & 0 \leq t < 1s, \\ 1000 \sin(3t), & 1s \leq t. \end{cases} \quad (75)$$

The disturbances are described by (72).

Since  $p = q$ , it follows that  $L = 0$  in Theorem 1. Giving appropriate parameters in Theorems 1 and 3, and calculating designed parameters, the simulation results are shown in Figs. 8-12.

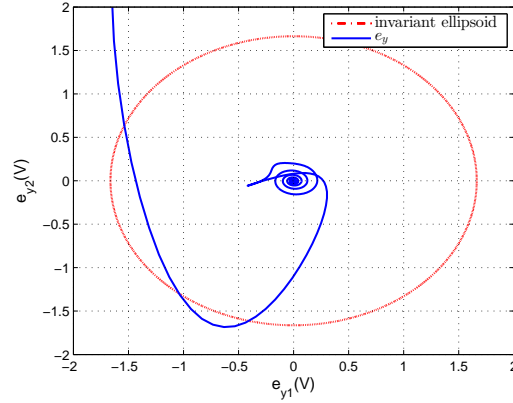

Fig. 8. Invariant ellipsoid  $\varepsilon(\mathcal{Q}^{-1})$  and estimation error  $e_y = \text{col}(e_{y1}, e_{y2})$ .

Fig. 8 confirms that the designed unknown input observer ensures that the estimation error  $\text{col}(e_1, e_y, e_\xi)$  converges to the invariant ellipsoid  $\varepsilon(\mathcal{Q}^{-1})$  even in the presence of disturbance  $d$  and time varying  $\xi$ . It is verified from Figs. 9 and 10 that the proposed fault-tolerant controller guarantees that the output voltages  $v_{od}$  and  $v_{oq}$  track the given voltage values with the tracking errors converging to the invariant ellipsoid  $\varepsilon(\mathcal{R}^{-1})$  given by Theorem 3. Moreover, after incipient



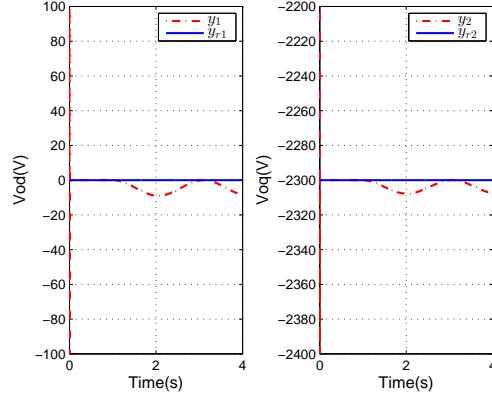

Fig. 9. Time response of the output voltages  $v_{od}$  and  $v_{oq}$ .

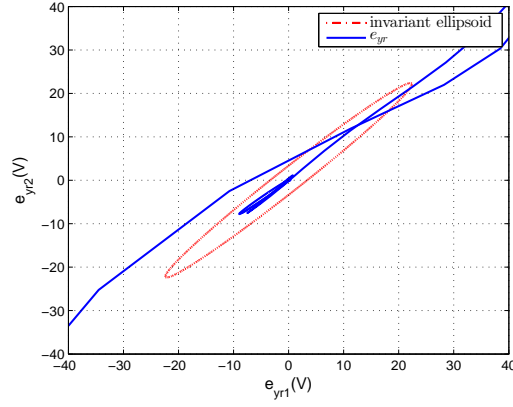

Fig. 10. Invariant ellipsoid  $\varepsilon(\mathcal{R}^{-1})$  and the voltage tracking error  $e_{yr} = \text{col}(e_{yr1}, e_{yr2})$ .

sensor faults occur, the tracking errors will stay in the invariant ellipsoid. It can be seen from Figs. 11 and 12 that the incipient fault signals are estimated by the proposed adaptive laws, and the estimation error converges to the invariant ellipsoid  $\varepsilon(Z^{-1})$ .

## VII. CONCLUSIONS

An incipient sensor fault estimation and accommodation method has been proposed for the three-phase PWM inverters used in the electric railway traction systems. An adaptive unknown input observer has been designed to estimate the inverter voltages, currents and incipient sensor faults. The inverter incipient sensor fault accommodation method also been developed to guarantee that the output voltages of the inverter system track the reference voltages irrespective

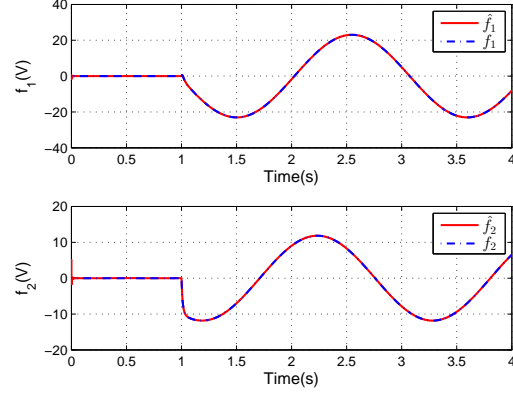

Fig. 11. Time response of the incipient sensor fault curves  $f = \text{col}(f_1, f_1)$  and fault estimation curves  $\hat{f} = \text{col}(\hat{f}_1, \hat{f}_1)$ .

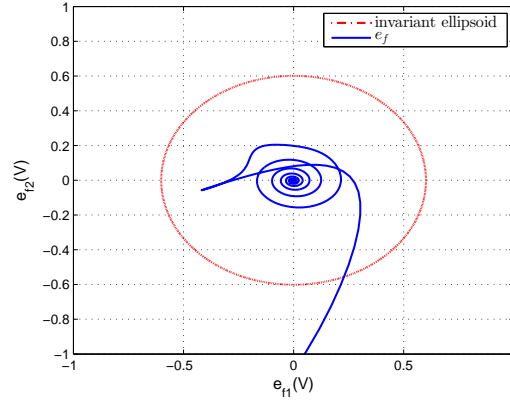

Fig. 12. Invariant ellipsoid  $\varepsilon(Z^{-1})$  and  $v_{oq}, v_{od}$  incipient sensor fault estimation error  $e_f = \text{col}(e_{f1}, e_{f2})$ .

of sensor faults occurrence. In the presence of disturbances, the invariant ellipsoid has been introduced such that the estimation errors and the voltage tracking errors converge to the corresponding invariant ellipsoid.

### VIII. ACKNOWLEDGEMENTS

This work is supported in part by the National Natural Science Foundation of China (Grant 61490703 and 61573180), Fundamental Research Funds for the Central Universities (NO. NE2014202) and the Priority Academic Program Development of Jiangsu Higher Education Institutions.

## REFERENCES

- [1] Brenna M, Foiadelli F. Analysis of the filters installed in the interconnection points between different railway supply systems. *IEEE Transactions on Smart Grid* 2012; 3(1): 551-558.
- [2] Bae C, Jang D, Kim Y. Calculation of regenerative energy in DC 1500V electric railway substations. *7th International IEEE Conference on Power Electronics* 2007; 801-805.
- [3] Youssef AB, Khil E, Khojet S. State observer-based sensor fault detection and isolation, and fault-tolerant control of a single-phase PWM rectifier for electric railway traction. *IEEE Transactions on Power Electronics* 2013; 28(12): 5842-5853.
- [4] Frank PM. Fault diagnosis in dynamic systems using analytical and knowledge-based redundancy: A survey and some new results. *Automatica* 1990; 26(3): 459-474.
- [5] Chen J, Patton RJ. *Robust Model-Based Fault Diagnosis for Dynamic Systems*. Springer Science Business Media, 2012.
- [6] Zhang Y, Jiang J. Bibliographical review on reconfigurable fault-tolerant control systems. *Annual Reviews in Control* 2008; 32(2): 229-252.
- [7] Wei X, Verhaegen M. LMI solutions to the mixed  $\mathcal{H}_2 - \mathcal{H}_\infty$  fault detection observer design for linear parameter varying systems. *International Journal of Adaptive Control and Signal Processing* 2011; 25(2): 114-136.
- [8] Lan J, Patton R J. Integrated design of robust fault estimation and fault-tolerant control for linear systems[C]//Decision and Control (CDC), 2015 IEEE 54th Annual Conference on. IEEE, 2015: 5105-5110.
- [9] Edwards C, Spurgeon SK, Patton RJ. Sliding mode observers for fault detection and isolation. *Automatica* 2000; 36(4): 541-553.
- [10] Tan CP, Edwards C. Sliding mode observers for detection and reconstruction of sensor faults. *Automatica* 2002; 38(10): 1815-1821.
- [11] Zhang J. Improved on-line process fault diagnosis through information fusion in multiple neural networks. *Computers chemical engineering* 2006; 30(3): 558-571.
- [12] Demetriou M, Polycarpou MM. Incipient fault diagnosis of dynamical systems using online approximators. *IEEE Transactions on Automatic Control* 1998; 43(11): 1612-1617.
- [13] Polycarpou MM, Trunov AB. Learning approach to nonlinear fault diagnosis: detectability analysis. *IEEE Transactions on Automatic Control* 2000; 45(4): 806-812.
- [14] X. Zhang, M.M. Polycarpou and T. Parisini, Fault diagnosis of a class of nonlinear uncertain systems with Lipschitz nonlinearities using adaptive estimation, *Automatica*, 2010; 46(2): 290-299.
- [15] X. Zhang, Sensor bias fault detection and isolation in a class of nonlinear uncertain systems using adaptive estimation, *IEEE Transactions on Automatic Control*, 2011; 56(5): 1220-1226.
- [16] Chen W, Chowdhury FN. Analysis and detection of incipient faults in post-fault systems subject to adaptive fault-tolerant control. *International Journal of Adaptive Control and Signal Processing* 2008; 22(9): 815C832.
- [17] Alwi H, Edwards C, Tan CP. Sliding mode estimation schemes for incipient sensor faults. *Automatica* 2009; 45(7): 1679-1685.
- [18] Yang G H, Ye D. Reliable control of linear systems with adaptive mechanism. *IEEE Transactions on Automatic Control*, 2010, 55(1): 242-247.
- [19] Gao Z, Ding SX. Actuator fault robust estimation and fault-tolerant control for a class of nonlinear descriptor systems. *Automatica* 2007; 43(5): 912-920.
- [20] Upchurch JM, González OR, Joshi SM. Identifiability of additive time-varying actuator and sensor faults by state augmentation. *Old Dominion University*, 2013.
- [21] Saif M, Guan Y. A new approach to robust fault detection and identification. *IEEE Transactions on Aerospace and Electronic Systems* 1993; 29(3): 685-695.

- [22] Jiang B, Staroswiecki M, Cocquempot V. Fault accommodation for nonlinear dynamic systems. *IEEE Transactions on Automatic Control* 2006; 51(9): 1578.
- [23] Edwards C, Tan CP. Sensor fault-tolerant control using sliding mode observers. *Control Engineering Practice* 2006; 14(8): 897-908.
- [24] Byrnes CI, Priscoli FD, Isidori A. *Output Regulation of Uncertain Nonlinear Systems*. Springer Science Business Media, 2012.
- [25] Marino R, Tomei P. Output regulation for linear systems via adaptive internal model. *IEEE Transactions on Automatic Control*, 2003, 48(12): 2199-2202.
- [26] Chattopadhyay S, Mitra M, Sengupta S. *Electric Power Quality*. Springer Netherlands, 2011.
- [27] Isermann R. *Fault-diagnosis systems: an introduction from fault detection to fault tolerance*. Springer Science Business Media, 2006.
- [28] Edwards C, Yan XG, Spurgeon SK. On the solvability of the constrained Lyapunov problem. *IEEE Transactions on Automatic Control* 2007; 52(10): 1982-1987.
- [29] Tan CP, Edwards C. Sliding mode observers for robust detection and reconstruction of actuator and sensor faults. *International Journal of Robust and Nonlinear Control* 2003; 13(5): 443-463.
- [30] Yan XG, Edwards C. Nonlinear robust fault reconstruction and estimation using a sliding mode observer. *Automatica* 2007; 43(9): 1605-1614.
- [31] Nazin S A, Polyak B T, Topunov M V. Rejection of bounded exogenous disturbances by the method of invariant ellipsoids. *Automation and Remote Control*, 2007, 68(3): 467-486.
- [32] Polyakov A, Poznyak A. Invariant ellipsoid method for minimization of unmatched disturbances effects in sliding mode control. *Automatica*, 2011, 47(7): 1450-1454.