



# Kent Academic Repository

**Wang, Lijuan, Liu, Jinyu, Yan, Yong, Wang, Xue and Wang, Tao (2016) *Gas-liquid Two-phase Flow Measurement Using Coriolis Flowmeters Incorporating Neural Networks*. In: *Proceedings of IEEE International Instrumentation and Measurement Technology Conference (I2MTC 2016)*. . pp. 747-751. IEEE ISBN 978-1-4673-9221-1. E-ISBN 978-1-4673-9220-4.**

## Downloaded from

<https://kar.kent.ac.uk/55769/> The University of Kent's Academic Repository KAR

## The version of record is available from

<https://doi.org/10.1109/I2MTC.2016.7520458>

## This document version

Author's Accepted Manuscript

## DOI for this version

## Licence for this version

UNSPECIFIED

## Additional information

## Versions of research works

### Versions of Record

If this version is the version of record, it is the same as the published version available on the publisher's web site. Cite as the published version.

### Author Accepted Manuscripts

If this document is identified as the Author Accepted Manuscript it is the version after peer review but before type setting, copy editing or publisher branding. Cite as Surname, Initial. (Year) 'Title of article'. To be published in *Title of Journal*, Volume and issue numbers [peer-reviewed accepted version]. Available at: DOI or URL (Accessed: date).

## Enquiries

If you have questions about this document contact [ResearchSupport@kent.ac.uk](mailto:ResearchSupport@kent.ac.uk). Please include the URL of the record in KAR. If you believe that your, or a third party's rights have been compromised through this document please see our [Take Down policy](https://www.kent.ac.uk/guides/kar-the-kent-academic-repository#policies) (available from <https://www.kent.ac.uk/guides/kar-the-kent-academic-repository#policies>).

# Gas-liquid Two-phase Flow Measurement Using Coriolis Flowmeters Incorporating Neural Networks

Lijuan Wang<sup>a</sup>, Jinyu Liu<sup>a</sup>, Yong Yan<sup>a</sup>, Xue Wang<sup>b</sup>, Tao Wang<sup>c</sup>

<sup>a</sup> School of Engineering and Digital Arts

University of Kent, Canterbury, Kent CT2 7NT, U.K.

<sup>b</sup> School of Mathematics, Statistics and Actuarial Science

University of Kent, Canterbury, Kent CT2 7NF, U.K.

<sup>c</sup> KROHNE Ltd., 34-38 Rutherford Drive, Wellingborough NN8 6AE, U.K.

**Abstract**—Coriolis flowmeters are commonly used to measure single phase flow. In recent years attempts are being made to apply Coriolis flowmeters to measure two-phase flows. This paper presents a neural network based approach that has been applied to Coriolis flowmeters to measure both the liquid flow rate and the gas void fraction of a two-phase flow. Experimental tests were conducted on a purpose-built two-phase flow test rig on both horizontal and vertical pipelines. The mass flow rate ranges from 700 kg/h to 14500 kg/h whilst the gas volume fraction is between 0 and 30%. A set of variables, including observed density, apparent mass flow, pressure of the fluid and signals to maintain flow tube oscillation, are considered as inputs to a neural network. Two neural networks are established through training with experimental data obtained from the flow rig on horizontal and vertical pipelines, respectively. The performance of both neural networks is assessed in comparison with the reference readings. Experimental results suggest that the relative errors of the corrected mass flow rate of liquid for the vertical and horizontal installations are no greater than  $\pm 1.5\%$  and  $\pm 2.5\%$ , respectively. The gas volume fraction is predicted with relative errors of less than  $\pm 10\%$  and  $\pm 20\%$ , respectively, for vertical and horizontal installations in most cases.

**Keywords**—two-phase flow; flow measurement; Coriolis mass flowmeter; gas volume fraction; neural network

## I. INTRODUCTION

Coriolis flowmeters for single-phase mass flow measurement have been successfully applied to a range of industrial applications particularly in oil field, food processing and chemical industries. In recent years, many researchers have attempted to use Coriolis flowmeters for two-phase or multiphase flow measurement. However, despite recent progress in sensor and transmitter technologies [1], the accuracy for liquid flow measurement with entrained gas in the liquid still remains a challenge. A bubble effect model was proposed to study gas-liquid two-phase flow for Coriolis flowmeters [2], but it cannot deal with positive errors in the mass flow measurement. Subsequently, Liu et al [3] used a neural network to correct mass flow errors in a Coriolis mass flowmeter which was based on a horizontal flow tube and the flow rate was limited to 1.5~3.6 kg/s. Although the mass flow errors were reduced to within 2%, the gas entrainment was not quantified and different installation conditions were not considered. A method based on fuzzy systems was proposed to

correct the mass flow errors of a Coriolis mass flowmeter for the measurement of two-phase flow [4]. Xing et al [5] applied Coriolis flowmeters in combination with an ultrasonic flowmeter to measure the individual mass flowrate of gas-liquid two-phase flow under low liquid loading. The root-mean-square errors of gas and liquid mass flowrates were 3.09% and 12.78%, respectively. Very little research has been undertaken to estimate the gas volume fraction (GVF) – an important characteristic parameter in a gas-liquid mixture, from the outputs of a Coriolis flowmeter.

In this paper, the principles of the measurement of liquid mass flow rate and GVF and using Coriolis flowmeters in conjunction with neural networks are described in detail. A range of experimental tests were conducted on a purpose-built two-phase flow rig on both horizontal and vertical pipelines. The characteristics of the original mass flow errors from Coriolis flowmeters are analyzed. Through a selection process, a set of variables that may be used as inputs to the neural network is considered. A three-layer neural network is established for the Coriolis flowmeter on each pipeline. In order to further improve the performance of the neural network, the initial weights and thresholds between the layers are optimized using a genetic algorithm. Experimental results suggest that the neural network based soft computing method is feasible and cost-effective for the measurement of the liquid mass flow rate as well as the gas volume fraction under two-phase flow conditions.

## II. METHODOLOGY

Neural Network (NN) is a common soft-computing method for modelling a nonlinear system with multiple inputs and outputs and has been widely used for a range of prediction and forecasting applications. In this study, a BP (back propagation) neural network is established for each Coriolis flowmeter under two-phase flow conditions for the correction of the measured liquid mass flow rate and the prediction of gas volume fraction. A BP NN comprises input layer, hidden layer and output layer. The input layer accepts variables from a Coriolis flowmeter and other sensors (differential pressure transducers in this study) while the output layer gives the corrected mass flow rate and predicted gas volume fraction. The hidden layer connects the input and output layers and represents their quantitative

relationships. Fig.1 shows the basic principle and structure of the measurement system.

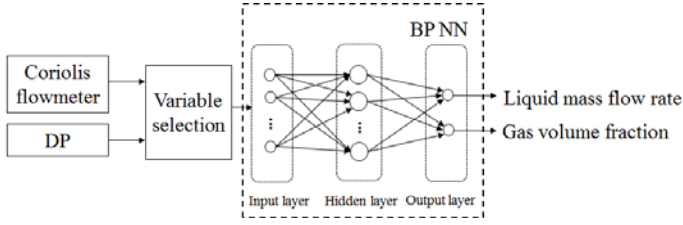

Fig. 1. Principle and structure of the measurement system.

The candidate inputs usually include variables which might be irrelevant to the target or redundant. Irrelevant inputs add noise and complexity to the model, while redundancy can increase the dimensionality of the model without providing any additional predictive benefit. Consequently, a key step before establishing the internal structure of a NN is to select the input variables, which affects the performance of the NN significantly. Forward selection is a classic and effective approach to variable selection in statistics. It is realized through adding variables to the NN one by one until no remaining variables (outside the model) can add anything significantly to the dependent variables [6-7]. In this study, five variables are considered, as listed in Table 1. The first four variables are from the Coriolis flowmeter while the last one is from a Differential Pressure (DP) transducer.

Table 1 Variables and corresponding symbols

Symbol	Variable
$x_1$	Observed density drop
$x_2$	Apparent mass flow
$x_3$	Sensor A / Sensor B ratio
$x_4$	Drive level / Sensor ratio
$x_5$	Differential Pressure

Normalized Root-Mean-Square Deviation (NRMSD) is used to assess the sensitivity of each variable on the performance of a NN. NRMSD is defined as

$$NRMSD = \frac{1}{\bar{y}} \sqrt{\frac{1}{n} \sum_{i=1}^n (y_i - \hat{y}_i)^2} \quad (1)$$

where  $y_i$  is the reference mass flow rate of the liquid phase or GVF,  $\bar{y}$  is the mean of  $y_i$ ,  $\hat{y}_i$  is the corrected mass flow rate or predicted GVF from the NN accordingly, and  $n$  is the number of samples used.

Apart from the input variables, initial weights and thresholds between the three layers affect the performance of the NN as well. The initial weights and threshold are produced randomly, which can fall into the local extreme points easily during the training process and cause slow convergence [8]. In order to determine an optimal set of initial weights and thresholds for the NN, a genetic algorithm is deployed, which is a powerful optimisation technique based on the underlying principles of natural evolution and selection [9-10]. The genetic algorithm used for NN optimization normally comprises five steps, including population initialization, fitness function, selection, crossover and mutation. All the members of the initial population are evaluated by an objective function and the

corresponding fitness values are used to determine the quality of the chromosome. In this study, the objective function  $f_o$  is defined as the norm of an error matrix between the predicted values and expected values, i.e.

$$f_o = \|\hat{Y} - Y\|_2 \quad (2)$$

where  $\hat{Y}$  is the matrix of the output variable sets, corrected mass flow rate  $\hat{y}_{1i}$  and predicted GVF  $\hat{y}_{2i}$ , i.e.  $\hat{Y} = (\hat{y}_{1i}, \hat{y}_{2i})$ ;  $Y$  is the matrix of the reference mass flow rate  $y_{1i}$  and GVF  $y_{2i}$ , i.e.  $Y = (y_{1i}, y_{2i})$ .

The fitness function is the ordered output from the objective function. A subset of chromosomes with the highest performance is selected from the set of fitness values as parent generation through a selection procedure. The genes of the parent generation are exchanged and recombined in a mating pool to form offspring for the next generation. The new chromosomes have superior characteristics than the previous generation. Once the evolution of all generations is completed, the optimal weights and thresholds are obtained.

### III. EXPERIMENTAL RESULTS AND DISCUSSION

#### A. Test Conditions

Fig.2 shows the schematic of the two-phase flow rig that was used in this study. The measurement data obtained on this test rig and subsequent conclusions drawn from the data are expected to be transportable to other liquid-gas two-phase flow conditions. Two independent Coriolis flowmeters were installed before the mixer to provide references for the individual mass flow rates of the liquid and gas phases. In the downstream, two additional Coriolis flowmeters of the same type were installed in the vertical and horizontal test sections, respectively. These are the meters under test to assess the performance of the NN approach. The mass flow accuracy of gas reference meter (mini CORI-FLOW™ M15) is  $\pm 0.5\%$  [11]. The Coriolis flowmeter on the water flow section was calibrated with the weighing scale before the test and the relative error was 0.0437%. In view of the effects of gravity and buoyancy on two-phase fluid, both horizontal and vertical installations of the meters are considered. A DP transducer was used to record the DP value across each flowmeter under test.

Two series of experimental tests, Tests I and Tests II, were conducted for the liquid mass flow rate ranging from 700 kg/h to 14500 kg/h and GVF from 0 to 30%, the latter corresponds to the observed density drop from 0 to 50%. The fluid temperature during the tests was around 20°C. For the purpose of NN training, 237 data sets were collected from Tests I while 23 data sets recorded from Tests II for testing the performance of the NN.

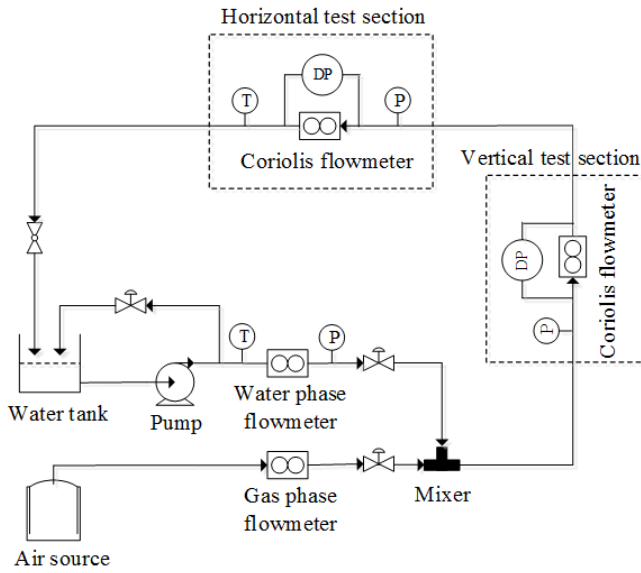

Fig. 2. Schematic of the two-phase flow rig.

### B. Variable selection

Tables 2 and 3 outline the logical steps and outcomes of the variable selection process for the mass flow rate correction and GVF prediction respectively. The most sensitive variables in each selection stage are underlined. From the two tables, we can see that variables  $x_1$ ,  $x_2$  and  $x_5$  affect the performance of the NN more significantly than the other two. The NRMSD is reduced slightly when variable  $x_4$  is added. At the Step IV in Table 2,  $x_3$  has negative effect on the performance of the model. Consequently,  $x_1$ ,  $x_2$ ,  $x_4$  and  $x_5$  are selected as the input variables to the NN for the correction of the mass flow rate as well as prediction of GVF.

Table 2 Variable selection for mass flow rate correction (NRMSD: %)

I	$x_1$	$x_2$	$x_3$	$x_4$	$x_5$
NRMSD	79.07	<u>5.72</u>	54.07	60.67	6.51
II	$x_1, x_2$	$x_2, x_3$	$x_2, x_4$	$x_2, x_5$	
NRMSD	<u>0.69</u>	4.45	1.19	4.42	
III	$x_1, x_2, x_3$	$x_1, x_2, x_4$	$x_1, x_2, x_5$		
NRMSD	0.73	0.62	<u>0.39</u>		
IV	$x_1, x_2, x_3, x_5$	$x_1, x_2, x_4, x_5$			
NRMSD	0.40	<u>0.35</u>			
V	$x_1, x_2, x_3, x_4, x_5$				
NRMSD	<u>0.37</u>				

Table 3 Variable selection for gas volume fraction prediction (NRMSD: %)

I	$x_1$	$x_2$	$x_3$	$x_4$	$x_5$
NRMSD	<u>26.41</u>	81.41	69.02	82.47	70.32
II	$x_1, x_2$	$x_1, x_3$	$x_1, x_4$	$x_1, x_5$	
NRMSD	<u>6.85</u>	10.61	12.18	12.85	
III	$x_1, x_2, x_3$	$x_1, x_2, x_4$	$x_1, x_2, x_5$		
NRMSD	8.05	9.74	<u>5.75</u>		
IV	$x_1, x_2, x_3, x_5$	$x_1, x_2, x_4, x_5$			
NRMSD	6.07	<u>5.66</u>			

### C. Experimental results

The typical uncorrected mass flow errors of the Coriolis flowmeters under test in Tests I are plotted in Fig. 3 and Fig. 4,

respectively. The Coriolis flowmeter on the vertical section gives negative errors at the flow rate below 4000 kg/h. At the higher flow rate, the mass flow errors become positive and crossing the zero line and then return to negative errors again. This is believed to be due to the effects of flow regime. At a lower flowrate, the flow was nearly plug flow as observed during test while the flow regime became gradually to dispersed bubble flow as the flowrate and entrained gas increase. For the Coriolis flowmeter on the horizontal pipeline, the range of mass flow error is larger than that on the vertical pipeline due to the effect of gravity and buoyancy. Positive errors occur under the condition of the mass flow rate of 700 kg/h and 1000 kg/h and observed density below 10%. For the same installation, the results are generally reproducible thanks to the new generation flow transmitter [12]. The mass flow errors in Figs. 5 and 6 are the results from Test II and have similar trend to Figs.3 and 4 respectively.

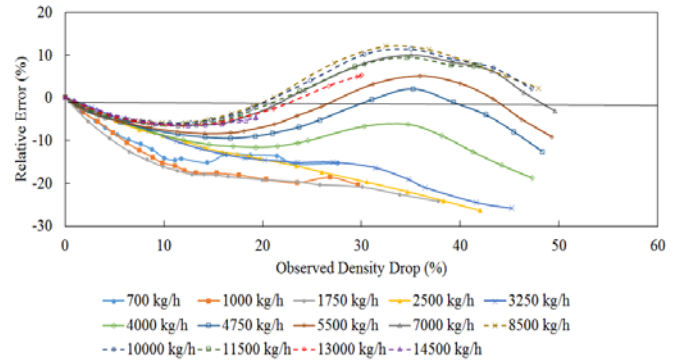

Fig. 3. Uncorrected mass flow errors on the vertical pipeline from Test I.

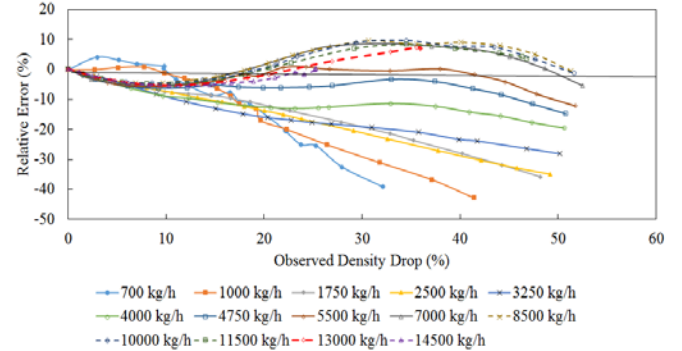

Fig. 4. Uncorrected mass flow errors on the horizontal pipeline from Test I.

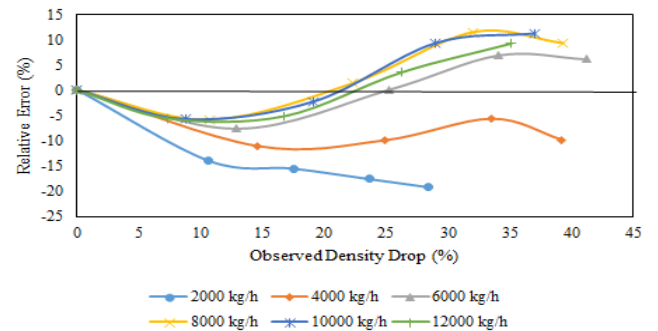

Fig. 5. Uncorrected mass flow errors on the vertical pipeline from Test II

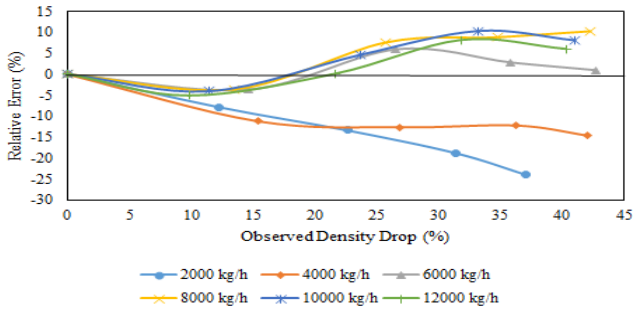
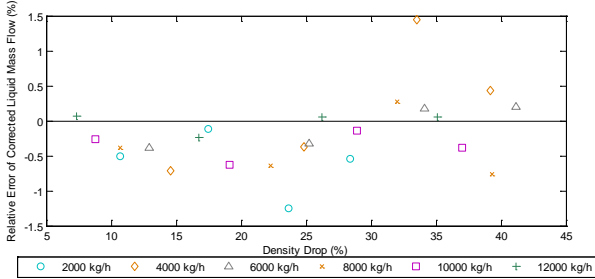
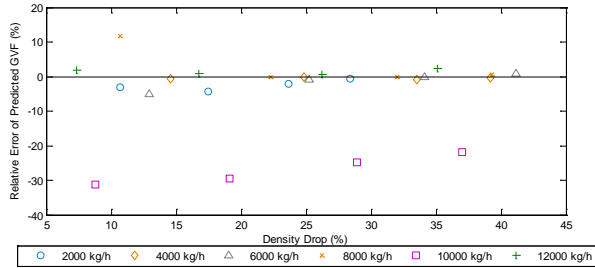

Fig. 6. Uncorrected mass flow errors on the horizontal pipeline from Test II

The experimental data from Test I are used to train the neural networks while the data from Test II was used for testing the performance of the networks. Figs. 7 and 8 depict the errors of the corrected mass flow rate and predicted GVF for vertical and horizontal installations, separately. The relative error of the corrected mass flow rate is found to be no greater than  $\pm 1.5\%$  for the vertical installation and  $\pm 2.5\%$  for the horizontal installation. Moreover, the large errors normally exist at lower mass flow rates. The error of the predicted GVF is within  $\pm 10\%$  and  $\pm 20\%$  for vertical and horizontal installations under the majority of the conditions.



(a) Corrected mass flow rate errors



(b) Predicted gas volume fraction errors

Fig. 7. Results from the neural network for the vertical installation.

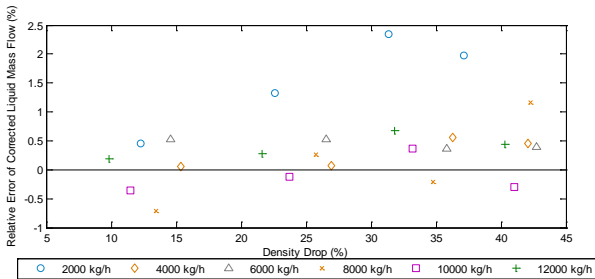

(a) Corrected mass flow rate errors

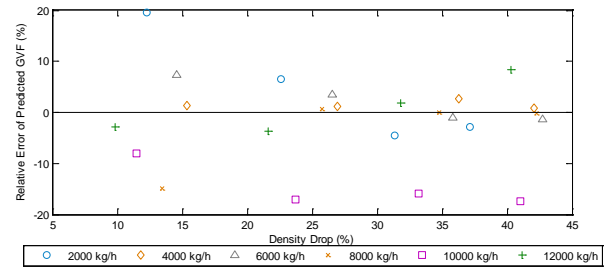

(b) Predicted gas volume fraction errors

Fig.8. Results from the neural network for the horizontal installation.

#### IV. CONCLUSIONS

A neural network based soft-computing method has been applied to measure gas-liquid two-phase flow rate using Coriolis mass flowmeters under different installation conditions. The effectiveness of this method has been verified through a range of experimental tests. Based on the experimental data from each meter, the relative error of the corrected mass flow rate is no greater than  $\pm 1.5\%$  and  $\pm 2.5\%$ , respectively, for the vertical and horizontal installations. In comparison with the original uncorrected errors, this approach has provided significant improvement in measurement accuracy. Additionally, the gas volume fraction is also predicted through the same NN and the relative error of the prediction is less than  $\pm 10\%$  and  $\pm 20\%$  for the vertical and horizontal installations in most cases. It must be stressed that the reduced errors in mass flow rate measurements from the Coriolis mass flowmeters and gas volume fraction predictions are achieved by using the existing data from the Coriolis flowmeters and a simple differential-pressure transducer without the use of any other devices. This outcome has effectively extended the applicability of Coriolis mass flowmeters such as liquid flow measurement with a significant volume of entrained gas. Effort will be made in future to improve the accuracy in GVF prediction. Meanwhile, the neural network approach will be extended to the measurement of other liquids with different viscosities under two-phase or multi-phase flow conditions.

#### REFERENCES

- [1] T. Wang and R. Baker, "Coriolis flowmeters: a review of developments over the past 20 years, and an assessment of the state of the art and likely future directions," *Flow Meas. Instrum.*, vol. 40, pp. 99-123, Sep. 2014.
- [2] J. Hemp and G. Sultan, "On the theory and performance of Coriolis mass flowmeters," in *Proc. of the International Conference on Mass flow measurement Direct and Indirect*, 1989.
- [3] R. Liu, M. Fuent, M. Henry and M. Duta, "A neural network to correct mass flow errors caused by two-phase flow in a digital Coriolis mass flowmeter," *Flow Meas. Instrum.*, vol. 12, no. 1, pp. 53-63, Sep. 2001.
- [4] B. Safarinejadian, M. Tajeddini and L. Mahmoodi, "A new fuzzy based method for error correction of Coriolis mass flow meter in presence of two-phase fluid," in *Proc. of International Conference on Artificial Intelligence and Image Processing*, pp. 192-196, 2012.
- [5] L. Xing, Y. Geng, C. Hua, H. Zhu and A. Rieder, "A combination method for metering gas-liquid two-phase flows of low liquid loading applying ultrasonic and Coriolis flowmeters," *Flow Meas. Instrum.*, vol. 37, pp. 135-143, Jan. 2014.
- [6] I. Guyon and A. Elisseeff, "An introduction to variable and feature selection," *J. Mach. Learn. Res.*, vol. 3, pp. 1157-1182, Mar. 2003.

- [7] B. Ratner, "Variable selection methods in regression: Ignorable problem, outing notable solution," *Journal of Targeting, Measurement and Analysis for Marketing*, vol. 18, pp. 65-75, 2010.
- [8] J. Jiang, "BP neural network algorithm optimized by genetic algorithm and its simulation," *International Journal of Computer Science Issues*, vol. 10, no. 2, pp. 516-519, 2013.
- [9] K. Ghosh, S. K. Parui and P. Majumder, "Learning combination weights in data fusion using genetic algorithms," *Information Processing and Management*, vol. 51, pp. 306-328, Jan. 2015.
- [10] S. M. Elsayed, R. A. Sarker and D. L. Essam, "A new genetic algorithm for solving optimization problems," *Engineering Application of Artificial Intelligence*, vol. 27, pp. 57-69, Oct, 2013.
- [11] [On-line] mini CORI-FLOW™ M15, [http://www.bronkhorst.com/files/coriolis/downloads/brochures-en/mini\\_cori-flow\\_m15.pdf](http://www.bronkhorst.com/files/coriolis/downloads/brochures-en/mini_cori-flow_m15.pdf), Accessed 3 January 2016.
- [12] J. W. Kunze, R. Storm and T. Wang, "Coriolis mass flow measurement with entrained gas," in *Proc. of Sensors and Measuring Systems 2014; 17. ITG/GMA Symposium, Nürnberg, 2014*.