



# Kent Academic Repository

**Qian, XC, Huang, XB, Hu, YH and Yan, Yong (2016) *Measurement of the Mass Flow Distribution of Pulverized Coal in Primary Air Pipes Using Electrostatic Sensing Techniques*. In: *Proceedings of IEEE International Instrumentation and Measurement Technology Conference (I2MTC 2016)*. . pp. 488-492. IEEE**

## Downloaded from

<https://kar.kent.ac.uk/55766/> The University of Kent's Academic Repository KAR

## The version of record is available from

<https://doi.org/10.1109/I2MTC.2016.7520412>

## This document version

Author's Accepted Manuscript

## DOI for this version

## Licence for this version

UNSPECIFIED

## Additional information

## Versions of research works

### Versions of Record

If this version is the version of record, it is the same as the published version available on the publisher's web site. Cite as the published version.

### Author Accepted Manuscripts

If this document is identified as the Author Accepted Manuscript it is the version after peer review but before type setting, copy editing or publisher branding. Cite as Surname, Initial. (Year) 'Title of article'. To be published in *Title of Journal*, Volume and issue numbers [peer-reviewed accepted version]. Available at: DOI or URL (Accessed: date).

## Enquiries

If you have questions about this document contact [ResearchSupport@kent.ac.uk](mailto:ResearchSupport@kent.ac.uk). Please include the URL of the record in KAR. If you believe that your, or a third party's rights have been compromised through this document please see our [Take Down policy](https://www.kent.ac.uk/guides/kar-the-kent-academic-repository#policies) (available from <https://www.kent.ac.uk/guides/kar-the-kent-academic-repository#policies>).

# Measurement of the Mass Flow Distribution of Pulverized Coal in Primary Air Pipes Using Electrostatic Sensing Techniques

Xiangchen Qian, Xiaobin Huang Yonghui Hu  
School of Control and Computer Engineering  
North China Electric Power University  
Beijing 102206, China  
xqian@ncepu.edu.cn

Yong Yan  
School of Engineering and Digital Arts  
University of Kent  
Canterbury, Kent CT2 7NT, UK  
y.yan@kent.ac.uk

**Abstract**—On-line measurement of pulverized fuel (PF) distribution between primary air pipes on a coal-fired power plant is of great importance to achieve balanced fuel supply to the boiler for increased combustion efficiency and reduced pollutant emissions. An instrumentation system using multiple electrostatic sensing heads are developed and installed on 510 mm bore primary air pipes of a 600 MW coal-fired boiler for the measurement of mass flow distribution of PF. An array of electrostatic electrodes with different axial widths is housed in a sensing head. An electrode with a greater axial width and three narrower electrodes are used to derive the electrostatic signals for the determination of PF mass flow rate and velocity, respectively. The measured PF velocity is used for the calibration of coal mass flow rate. On-plant comparison trials of the developed system were conducted under typical operating conditions. Isokinetic sampling equipment is used to obtain reference data to evaluate the performance of the system. Experimental data demonstrate that the developed system is effective and reliable for the on-line continuous measurement of PF mass flow distribution between the primary air pipes of the same mill.

**Keywords**—Pulverized coal; fuel distribution; power plant; electrostatic sensor; gas-solid two-phase flow

## I. INTRODUCTION

About 40% of the electricity in the world was generated from coal in 2014, and the demand for coal will increase 2.1% annually in the coming five years [1]. However, coal-fired power stations face challenges to enhance energy conversion efficiency and to produce less pollutant emissions. Measurement techniques have an important part to play to combat the above challenges. On-line measurement of the mass flow rate of pulverized coal in a fuel injection pipeline is of primary importance for the control of fuel transportation, balancing fuel distribution between primary air pipes, and optimization of the combustion process.

The mass flow measurement of PF has been recognized as a long-standing industrial problem because the PF particles in a primary air pipe are very dilute with a volumetric concentration of less than 0.1% and are inhomogeneously distributed in the pipe with a highly irregular velocity profile. Very few sensing techniques are available to cover the whole cross-section of a primary air pipe with a diameter ranging from 400 mm to 650

mm. Therefore, instruments based on ultrasonic, microwave and imaging techniques have never performed satisfactorily on power stations due to their inherent limitations in sensing principles and applicability [2]. Electrostatic induction based ring-shaped sensors offer a prospective solution to the measurement problem due to its advantages for industrial use, such as robustness, non-intrusiveness in installation, large cross-sectional sensing volume, low cost and less maintenance requirements [3]. The electrostatic sensing principle has been known for over three decades [4]–[6]. Substantial effort has been made to relate the characteristics of electrostatic signals from various types of electrostatic sensors to the mass flow rate of pneumatically conveyed particles through both laboratory tests [7]–[12] and industrial trials [11]–[12]. The root-mean-square (rms) magnitude (rms charge level) of an electrostatic signal is used as an indication of the volumetric concentration of particles under steady, dilute-phase flow conditions [8]–[11]. Gajewski suggested that the rms value of an electrostatic signal can be used to directly measure the mass flow rate of PVC dust over the velocity range below 20 m/s if the effect of particle velocity has been compensated [5]. Zhang proposed a theory that the rms charge level of pneumatically conveyed fillite particles and its mass flow rate have a second order polynomial relationship when the air-to-solids ratio between 1.92 and 3.86 [9]. Qian et al developed an arc-shaped electrostatic sensor array based pulverized coal flow monitoring system for on-line measurement of fuel particle velocity and fuel mass ration among the fuel pipes of the same mill [11]. Jurjevčič et al used a matrix of rod electrostatic sensors to determine the mass flow distribution in the cross-section of a duct that feeds the pulverized lignite to four burner nozzles by measuring the transferred electrostatic charge and velocity of coal particles [12]. However, it is still challenging to develop a reliable system that is operational on a full-scale power plant because the above techniques are based either on complicated calibration tests or on localized and intrusive measurement.

In this study, an instrumentation system comprising five independent electrostatic sensing heads and a central data analysis station was implemented and installed on 510 mm bore primary air pipes from the same pulverizing mill of a 600 MW coal-fired boiler unit. Comparison trials of the developed system were undertaken under a range of flow conditions for

the mass flow distribution measurement of PF. Isokinetic sampling equipment was used to obtain reference data and calibrate the system under test.

## II. MEASUREMENT PRINCIPLES

In coal-fired power stations, bulk coal is pulverized into fine particles and then pneumatically conveyed towards a matrix of burners via a primary air pipe network. Pulverized coal particles become electrically charged during pneumatic transportation in primary air pipes. As the charged particles move through the sensing zone of a measurement sensor, induced electrostatic charge will appear on the surface of the sensor. As an indication of volumetric concentration ( $\beta_s$ ) of PF particles, the rms charge level is more sensitive to the particle velocity than the mass flow rate and other parameters [4],[5],[8]–[11]. Thus, the accurate measurement of the particle velocity is vital for mass flow rate measurement.

Fig. 1 shows the basic principle and structural design of the latest model of the PF flow measurement system. As can be seen from Fig. 1, three identical narrow electrodes and one wider electrode are used to derive the electrostatic signals from the PF flow. The narrow electrodes yield a wider signal bandwidth and are used to measure PF velocities through cross-correlation velocimetry [4],[10]–[11]. The use of three narrow electrodes is a trade-off between fast system response, measurement reliability and compactness of the sensing head. The transit time taken by PF particles to move from the upstream electrode  $i$  to the downstream electrode  $j$  is determined from the location of the dominant peak ( $r_{ij}$ ,  $i, j = 1, 2$  or  $3$ ) in the correlation function [11]. Since the spacing between the two corresponding electrodes is known, the individual PF velocity ( $v_{ij}$ ) is then derived. The weighted average PF velocity ( $v_c$ ) is determined by fusing the three individual velocities:

$$v_c = (r_{12}v_{12} + r_{23}v_{23} + r_{13}v_{13}) / (r_{12} + r_{23} + r_{13}) \quad (1)$$

The wide electrode, which has a larger sensing volume and better spatial filtering effect [4], is applied to infer the volumetric concentration of PF. Digital signal processing algorithms are applied to optimize the non-uniform spatial sensitivity of the sensing field.

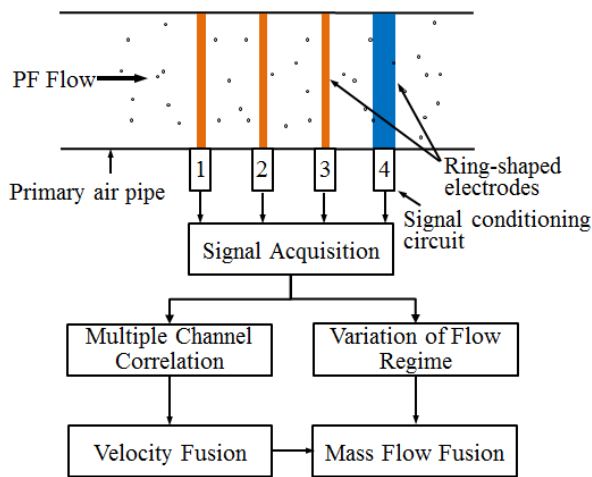

Fig. 1. Structure and principle of the measurement system.

The mass flow rate of PF particles is derived from the rms charge level and the cross-sectionally averaged velocity of PF:

$$q_{m,s} = A_p \rho_s v_c \beta_s = a v_c^b A_{rms} \quad (2)$$

where  $A_p$  is the cross-sectional area of the pipe,  $\rho_s$  is the true density of coal,  $A_{rms}$  is the rms charge level of the electrostatic signal,  $a$  is a proportionality coefficient that mainly relates to fuel properties and coefficient  $b$  represents the dependence of the rms value on particle velocity and variation of flow regime. Coefficients  $a$  and  $b$  are determined through a calibration process using isokinetic sampling equipment [11]. Since the properties of PF particles in the pipes from the same pulverizing mill are very similar, the fuel distribution between the primary air pipes of the same mill is presented by the percentage share of each individual mass flow rate normalized to the total mass flow rate of that mill.

## III. SYSTEM IMPLEMENTATION AND INSTALLATION

Fig. 2 shows the implementation and installation of the sensing heads on the 510 mm bore primary air pipes of the pulverizing mill of a 600 MW boiler. Three identical narrow electrodes and one wider ring-shaped electrodes are embedded in the stainless steel sensing head base and insulated from each other using wear-resistant insulation material. The inner surface of the sensing head is made flush with the inner pipe wall. An embedded electronic circuit is used for the conditioning and processing of the electrostatic signals. The weak current signals from the electrodes are transformed to voltage signals and amplified and filtered by the signal conditioning module. The analog signals are then converted into a digital form via a synchronous sampling analog-to-digital convertor for the flow parameter calculation by a signal processing module.

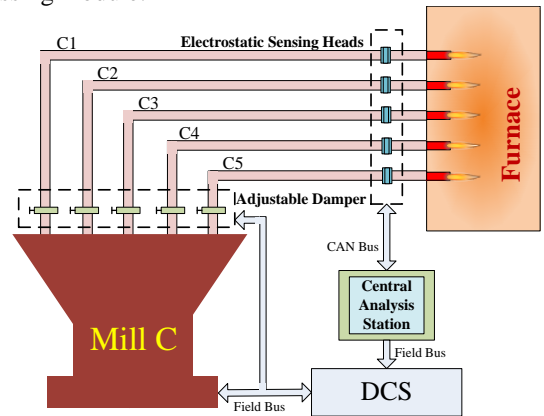

(a) Installation of the instrumentation system on the plant.

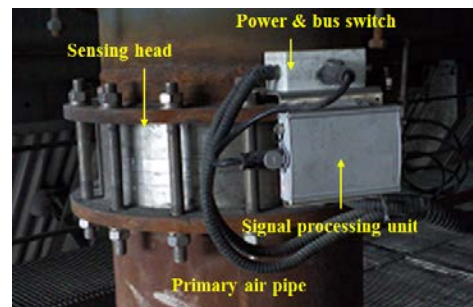

(b) Implementation and installation of a sensing head.

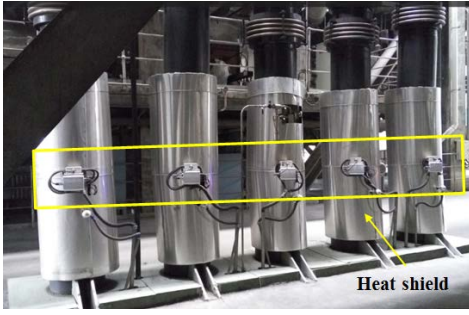

(c) Installation of five sensing heads on mill C.

Fig. 2. Implementation and installation of the PF measurement system.

As can be seen from Fig. 2(a), the electronic circuit is enclosed in a grounded metal box to receive the weak electrostatic signal from the electrodes through grounded shield cables. In order to determine fuel distribution between the PF pipes from the same mill, all the mechanical and electrical components of the sensing heads are made identically to each other. The flow parameters determined by each sensing head are transmitted to the central data analysis station through a controller area network (CAN). The central data analysis station is also used to control the operation parameters of the sensing heads. The measurement data are sent to the distributed control system (DCS) of the power plant for automated control of the mill and fuel supply system.

#### IV. MEASUREMENT RESULTS AND DISCUSSION

##### A. System Calibration Tests

System calibration tests were undertaken on primary air pipe C1 under six different conditions. The test conditions are summarized in TABLE I. The mass flow rate of PF and primary air velocity in the pipe were kept steady during each test stage. The coefficients  $a$  and  $b$  in equation (2) were derived for the measurement data from the developed system and the flow parameters measured by isokinetic sampling equipment. With the use of the isokinetic sampling equipment, as shown in Fig. 3, the PF mass flow rate was obtained for 15 seconds at each of the 49 sampling points over the cross-section of the pipe. The total duration of collecting the data over the pipe cross section was about 15 mins. The cross-sectionally averaged velocity of the primary air was calculated based on the air velocities measured at ninth points across the diameter of the pipe cross-section.

Fig. 4 shows the measured PF velocity, rms charge level and mass flow rate using the developed system (during a selective period of time in each test stage), along with the primary air velocity and PF mass flow rate measured from the isokinetic sampling equipment. Fig. 4(a) compares the conveying air velocity with PF velocity. It is evident that the PF velocity is consistent with the trend of the air velocity. The variation of PF mass flow rate has less effect on the PF velocity than that of air velocity because the volumetric concentration of PF in the two-phase flow is as dilute as about 0.05%. The averaged slip velocity between the PF and the conveying air in each test stage is between 0.79 m/s and 1.71 m/s and the maximum relative deviation between them is 4.73%. As shown in Fig. 4(b), the rms charge level fluctuates when either the

coal mass flow rate or air velocity changes. When either of the two factors is fixed, the rms charge level follows the variation trend of the other. In the short transition stage IV, the RMS charge level is steady as the coal mass flow rate and air velocity vary contrarily.

TABLE I. CALIBRATION TEST CONDITIONS

Test Conditions	Test stages					
	I	II	III	IV	V	VI
PF Mass Flow (t/h)	8.0	8.0	8.0	8.0→9.0	9.0	7.0
Air Velocity (m/s)	23.8	21.4	26.0	26.0→23.6	23.6	23.6

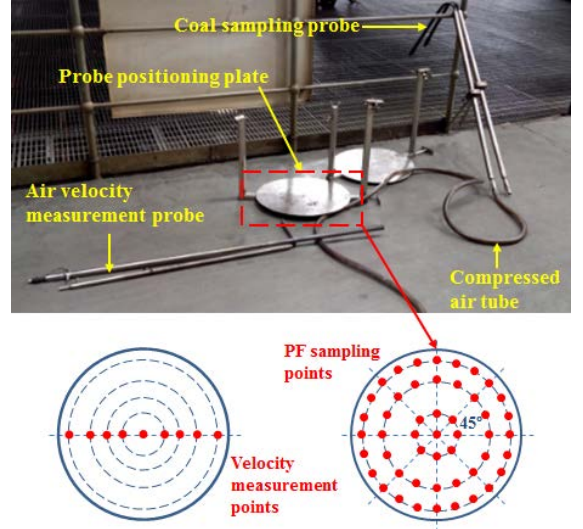
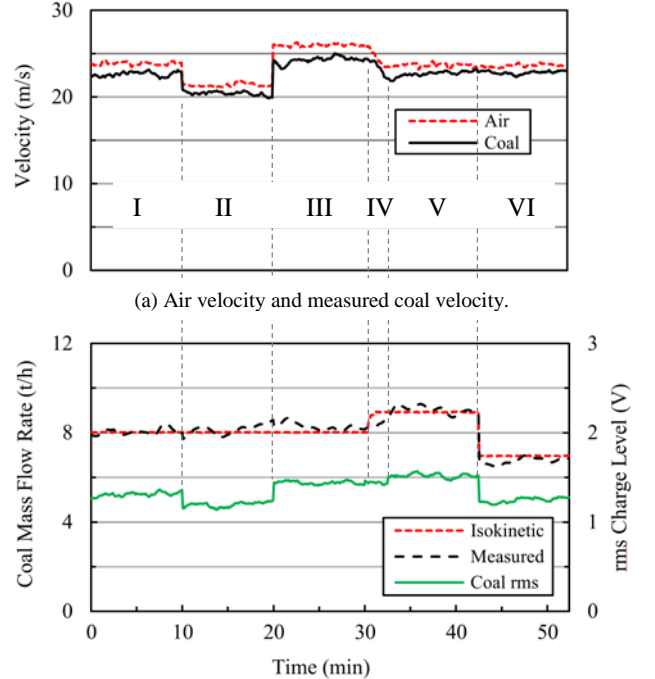

Fig. 3. Isokinetic sampling equipment.



(b) Coal mass flow rates with corresponding rms charge level.

Fig. 4. Test results for variable coal and air flow rate.

The measured PF mass flow rate using equation (2) matches closely the coal mass flow rate obtained from the isokinetic sampling equipment with a mean relative error of less than 2.54%.

### B. Comparison Trials

The comparison trials on five primary air pipes of mill C were undertaken using the developed instrumentation system and the isokinetic equipment under three different flow conditions (as shown in TABLE II). The mass flow rates of air and PF were both set constant in the DCS of the plant during each test stage. The measured PF mass flow distributions using the two different methods are illustrated in Fig. 5. The proportional relations of PF in the five primary air pipes determined from the developed system and the isokinetic sampling equipment are very similar under all three test stages.

TABLE II. CONDITIONS FOR COMPARISON TRIALS

Test Conditions	Test stages		
	VII	VIII	IX
PF Mass Flow (t/h)	35.0	40.0	40.0
Air Mass Flow (t/h)	100.0	100.0	110.0
Mass Flow Ratio of Air to PF	2.86	2.50	2.75
$R_{90}^a$	20.7	19.4	23.0

<sup>a</sup>. Percentage of the coal particles with an equivalent diameter greater than 90  $\mu\text{m}$ .

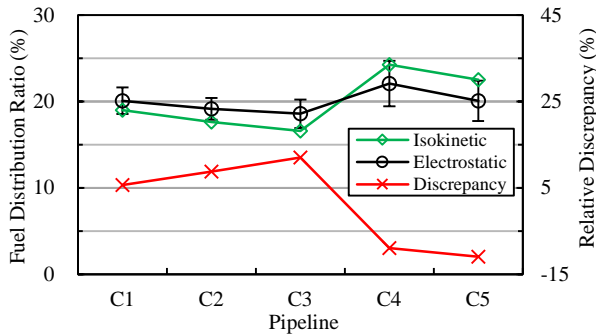

(a) Test results for coal flow rate 35 t/h and air flow rate 100 t/h.

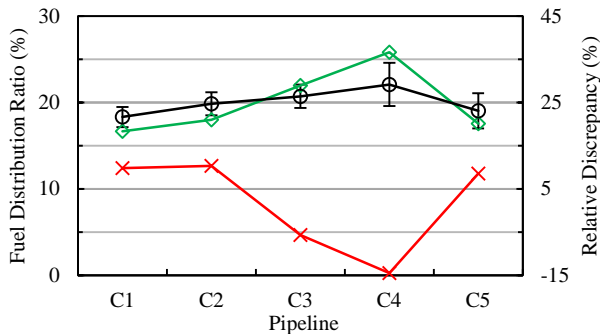

(b) Test results for coal flow rate 40 t/h and air flow rate 100 t/h.

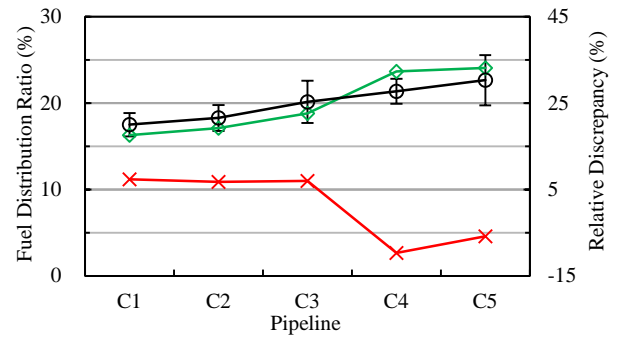

(c) Test results for coal flow rate 40 t/h and air flow rate 110 t/h.

Fig. 5. Comprison of PF distribution under three different flow conditons.

Due to the difference in measurement principles and practical operation between the two methods, the discrepancy between the highest and the lowest distribution ratio (7.67%, 9.14% and 7.77%) measured from the isokinetic sampling equipment is greater than that from the electrostatic system (3.51%, 3.76 and 5.16%). The relative error in mass flow distribution measurements between the electrostatic system and the isokinetic sampling equipment is no greater than  $\pm 15\%$ , and the averaged absolute deviation is within 9%. The averaged standard deviations of measured PF mass flow rate of pipes C1 to C5 during test stages VII, VIII and IX are 1.76%, 1.59% and 1.69%, respectively. By comparing these values with the corresponding air to PF ratio, we can infer that the PF flow rate fluctuates slightly more significantly as the solids phase in the flow becomes more dilute.

### V. CONCLUSIONS

The developed instrumentation system with five sensing heads has been implemented and installed on a 600 MW boiler unit of a commercial power station. The on-plant comparison trials that using the developed system and the isokinetic sampling equipment were conducted under typical operating conditions after a series of system calibration tests. The results from the comparison trials have demonstrated that effective and reliable mass flow distribution measurement of pulverized coal between the primary air pipes of the same mill is realized under a range of real industrial conditions. The results have indicated that the maximum relative deviation between the PF and the conveying air is 4.73%, the mean relative error of the measured PF mass flow rate is less than 2.54%, and the relative error in mass flow distribution measurements is no greater than  $\pm 15\%$ . It is envisioned that the deployment of the system will enable the plant operators to achieve on-line monitoring of fuel distribution between primary air pipes and allow the plant operators to control and optimize the fuel supply under variable operating conditions.

### ACKNOWLEDGMENT

Acknowledgments are made to the Chinese Ministry of Science and Technology (No. 2012CB215203) and the Chinese Ministry of Education (No. B13009) for funding this research. The authors would also like to thank technical staff at Changzhou Power Station, China Guodian Co. and Xi'an Thermal Power Research Institute, China, for their assistance during the on-plant trials.

## REFERENCES

- [1] International Energy Agency, Coal Medium-Term Market Report 2014, Organization for Economic Co-operation and Development (OECD), 2014.
- [2] Y. Zheng and Q. Liu, "Review of techniques for the mass flow rate measurement of pneumatically conveyed solids," *Measurement*, vol. 44, pp. 589-604, 2011.
- [3] Department of Trade and Industry (DTI). Multiphase flow technologies in coal-fired power plants, Technical Report, London, 2004.
- [4] Y. Yan, B. Byrne, S. Woodhead, and J. Coulthard, "Velocity measurement of pneumatically conveyed solids using electrodynamic sensors," *Meas. Sci. Technol.*, vol. 6, pp. 515-537, 1995.
- [5] J.B. Gajewski, "Electrostatic nonintrusive method for measuring the electric charge, mass flow rate, and velocity of particulates in the two phase gas-solid pipe flows—Its only or as many as 50 years of historical evolution," *IEEE Trans. Ind. Appl.*, vol. 44, pp. 1418-1430, 2008.
- [6] C. Xu, S. Wang, G. Tang, D. Yang, and B. Zhou, "Sensing characteristics of electrostatic inductive sensor for flow parameters measurement of pneumatically conveyed particles," *J. Electrostat.*, vol. 65, pp. 582-92, 2007.
- [7] Y. Yan, B. Byrne, and J. Coulthard, "Sensing field homogeneity in mass flow rate measurement of pneumatically conveyed solids," *Flow Meas. Instrum.*, vol. 8, pp. 115-119, 1995.
- [8] Y. Yan, "Mass flow measurement of bulk solids in pneumatic pipelines," *Meas. Sci. Technol.*, vol. 7, pp. 1687-1706, 1996.
- [9] J. Zhang, "Air-solids flow measurement using electrostatic techniques," in *Electrostatics*, H. Canbolat, Ed. Rijeka, Croatia: InTech, 2012, pp. 61-80.
- [10] X. Qian and Y. Yan, "Flow measurement of biomass and blended biomass fuels in pneumatic conveying pipelines using electrostatic sensor-arrays," *IEEE Trans. Instrum. Meas.*, vol. 61, pp. 1343-1352, 2012.
- [11] X. Qian, X. Huang, Y. Hu, and Y. Yan, "Pulverized coal flow metering on a full-scale power plant using electrostatic sensor arrays," *Flow Meas. Instrum.*, vol. 40, pp. 185-191, 2014.
- [12] B. Jurjevčič, A. Senegačnik, B. Drobinč, and I. Kuštrin, "The characterization of pulverized-coal pneumatic transport using an array of intrusive electrostatic sensors," *IEEE Trans. Instrum. Meas.*, in press.
- [13] H.L. Hu, J. Dong, J. Zhang, Y.J. Cheng, and T.M. Xu, "Identification of gas/solid two-phase flow regimes using electrostatic sensors and neural-network techniques," *Flow Meas. Instrum.*, vol. 22, pp. 4852-4857, 2011.
- [14] W. Zhang, C. Wang, and H. Wang, "Hilbert-huang transform-based electrostatic signal analysis of ring-shape electrodes with different widths," *IEEE Trans. Instrum. Meas.*, vol. 61, pp. 1209-1217, 2012.