



Kent Academic Repository

D'Elia, Samuel C (2016) *The Spray/Load and Dative Alternations: Aligning VP Structure and Contextual Effects*. Doctor of Philosophy (PhD) thesis, University of Kent,.

Downloaded from

<https://kar.kent.ac.uk/54773/> The University of Kent's Academic Repository KAR

The version of record is available from

This document version

UNSPECIFIED

DOI for this version

Licence for this version

UNSPECIFIED

Additional information

Versions of research works

Versions of Record

If this version is the version of record, it is the same as the published version available on the publisher's web site. Cite as the published version.

Author Accepted Manuscripts

If this document is identified as the Author Accepted Manuscript it is the version after peer review but before type setting, copy editing or publisher branding. Cite as Surname, Initial. (Year) 'Title of article'. To be published in *Title of Journal*, Volume and issue numbers [peer-reviewed accepted version]. Available at: DOI or URL (Accessed: date).

Enquiries

If you have questions about this document contact ResearchSupport@kent.ac.uk. Please include the URL of the record in KAR. If you believe that your, or a third party's rights have been compromised through this document please see our [Take Down policy](https://www.kent.ac.uk/guides/kar-the-kent-academic-repository#policies) (available from <https://www.kent.ac.uk/guides/kar-the-kent-academic-repository#policies>).

The Spray/Load and Dative Alternations:
Aligning VP Structure and Contextual
Effects.

by

Samuel C. D'Elia

A Thesis Submitted in Partial Fulfilment of the
Requirements for the Degree of

DOCTOR OF PHILOSOPHY

in

Linguistics

School of European Culture and Languages, University of Kent

ACKNOWLEDGEMENTS

The process of writing this thesis has involved the support of many people on many different levels. I took this journey voluntarily but I at no point have I ever had to endure it alone. Without the unwavering support of those around me I would not in the position that I am now. I owe thanks to so many people who have blessed me with their expertise, guidance, encouragement, and emotional support.

On this venture, the guidance, infinite patience, and expertise of my primary supervisor have been indispensable. Vikki Janke has inspired me since I was an undergraduate. She was the first to introduce me to syntax and the world of experimental linguistics, and this has been my passion ever since. Vikki has never let me be complacent with my knowledge and has encouraged me to push the boundary of what I thought I was capable of. There are too many things to thank her for here so I will list but a few. Vikki has always given me her time without question, and has always been ready to meet and discuss any readings, questions or drafts that I have submitted. She has meticulously read and reread all my writing to which I am incredibly appreciative. Her approach is always positive which without doubt has helped me immensely. She also has a talent for asking the kind of questions that are required to hone ones knowledge and reasoning skills. She has gone beyond the call on many occasions to help me to network with leading scholars and to support me through setbacks and doubtful times that I have had. I found her no nonsense approach refreshing and inspirational. I could not have completed my research without her.

I was also privileged to have Laura Bailey as my second supervisor at the end of my first year. Laura is an inspirational example whose dedication to the field is admirable. She has always offered me an open door, and has always been happy to meet with me. She has helped me in the preparation of a number of abstracts and conference presentations, and has always read any work that I have given her. Her advice is always erudite and she has shown amazing patience with me throughout. As a supervisory unit, I could not have asked for better.

I also want to thank Ad Neeleman, Christoph Scheepers, Jason Merchant, and Mira Ariel who offered guidance, and gave up their time for tutorials at various stages of my research. Their time and knowledge has been invaluable.

I especially want to thank my family – my wife Liat and my children Imogen, Noah, and Sebastian. They give me motivation every day to keep pushing on and have allowed me the freedom to research. Their dedication to my cause at times has shadowed my own. Their interest in my work and the excitement at my completion has helped to make this endeavour such a worthwhile enterprise. They have shared in the highs and suffered in the lows which I have experienced in writing this thesis. They have lived the student life with me without question, and I cannot express how much that I owe them for their emotional support. Every day they remind me to love and appreciate the life that I have and the wonderful people that I have around me. I am truly blessed to have such love and support which has been essential in keeping me on this path; even if this was just a smile when things were difficult, or a late night mug of tea as I frantically hammered away at the keyboard. I would also like to thank my mum, Terri and dad, Roger and my parents-in-law, Uri and Dorit who have loved and supported me and my family throughout this journey. I owe a special thanks to my father-in-law Uri who was dedicated to keeping me focussed by injecting me with realism, and he has demonstrated that he has had my back throughout this time.

I would like to express my appreciation to the University of Kent for their support. The university awarded me a generous scholarship to carry out my research without which I would not be here.

Without this unique package of support from such a wonderful group of people I would not be here today. I hope that my work in some way reflects the dedication of all of these people.

Declaration

I declare that this thesis is my own work carried out under normal terms of supervision.

Abstract

The theoretical and experimental work presented in this thesis investigates the spray/load and dative alternations. The purpose is to provide a comprehensive analysis of the alternations in terms of their syntactic structures and to account for how contextual information drives differences in the linear order of their VP arguments. This analysis shows that the syntactic structures of the spray/load and dative alternations are identical; each variant in an alternation is characterised by one of two available structures proposed in Janke and Neeleman (2012). Each structure is shown to respect a novel thematic hierarchy that is based on the value of binary feature clusters (Reinhart, 2000) rather than by direct reference to semantic labels. The choice of a particular structure is demonstrated to be affected by the non-semantic context in which the spray/load or dative sentence is generated. This is a consequence of the limited processing capacity of Working Memory and the allocation of attentional resources to a stimulus. Experimental data from an as yet untested variable of the visual context – the egocentric perception of distance – is found to interact with word order preferences of the alternations. I conclude that non-semantic contextual information interacts with the encoding of an event which ultimately has consequences for syntactic choices.

TABLE OF CONTENTS

CHAPTER 1	Background	1
1.1	Introduction	1
1.2	What is an alternation?.....	3
1.3	What is a double complement alternation?.....	4
1.4	Properties of double complement structure	5
1.5	The spray/load alternation	6
1.6	The dative alternation	7
1.7	Thematic roles	10
CHAPTER 2	Literature review	14
2.1	Theta roles and argument structure	14
2.2	Conditions on theta role assignment	15
2.3	Uniqueness	17
2.4	Syntactic restrictions on theta-assigned arguments	18
2.5	The ‘Thematic Hierarchy’	18
2.6	The Theta System	21
2.6.1	Goal/recipients and goal/locations.....	24
2.6.2	Conflating possessors and recipients	25
2.7	Rules that govern the co-occurrence of theta clusters	28
2.8	The mapping of theta relations to syntax	30
2.9	A feature cluster hierarchy.....	34
2.9.1	The ordering of values	35
2.10	The syntax of double-complements.....	40
2.11	The structures of double complement structures	41
2.11.1	A uniformly ascending tree structure and its problems	42
2.11.2	A uniformly descending tree structure	52
2.11.3	Problems with Larson’s analysis	63
2.12	Ascending and descending verb phrases in English	68
2.13	The general pattern for anaphoric dependency	73
2.14	The feature cluster hierarchy and double-complement structures	79
2.15	Semantics and Construction Grammar	84
2.15.1	What is a construction?.....	87
2.15.2	The fusion of verb and construction	88
2.16	Constructing constructions	93
2.16.1	Constructing the cause-motion construction	93
2.16.1.1	Semantic compatibility and the cause-motion construction	95
2.16.1.2	Spray/load verbs and the cause-motion construction.....	98
2.16.2	Constructing the cause-to-receive construction	100
2.16.2.1	Semantic compatibility and the cause-to-receive construction.....	103
2.16.3	The change-of-state-plus-adjunct construction	106
2.16.3.1	Semantic compatibility and the change-of-state construction	106
2.17	Problems with the Construction Grammar approach	110
2.17.1	Problems with the fusion of verb and construction roles	110

2.17.2	Problems with the compatibility of verb and construction	115
2.17.3	Problems with the Construction Grammar account of the <i>with</i> -variant construction	122
2.17.3.1	Problems with an <i>instrument</i> analysis	122
2.17.3.2	Problems with an <i>adjunct</i> analysis	127
2.18	The effect of context on argument order	133
2.18.1	Working memory	134
2.18.1.1	Attention and the selection of information	135
2.18.2	The egocentric perception of distance	137
2.18.2.1	Relative size	139
2.18.2.2	Height in the visual field	139
2.18.3	The egocentric perception of distance and its effect on attention.....	140
2.19	Chapter summary	143
CHAPTER 3	Comparing structures	146
3.1	Comparing structures from the spray/load alternation with structures from the dative alternation.....	146
3.2	Comparing the locative construction with the dative construction	146
3.3	Comparing the <i>with</i> -variant construction with the double-object construction	150
3.4	Evidence for Parallelism	153
3.4.1	Scope	153
3.4.1.1	Quantifier scope	153
3.4.1.2	The unavailability of pair-list readings in <i>wh</i> -questions	154
3.4.1.3	Failure of variable binding	155
3.4.2	Passive formation	156
3.4.3	Deverbal nominalisations	159
3.4.4	Ellipsis	163
3.4.4.1	Sluicing	163
3.4.4.2	<i>Do so</i> anaphora	167
3.4.5	Floating quantifiers	170
3.5	Evidence against parallelism	174
3.5.1	Unaccusative sentences	174
3.5.2	Synthetic compounds	178
3.5.3	<i>Right</i> and verb particles	180
3.5.4	A-bar movement	182
3.5.4.1	Wh-movement	183
3.5.4.2	<i>Tough</i> Movement	186
3.5.4.4	Relativisation	188
3.6	Chapter summary	191
CHAPTER 4	Establishing a baseline preference for the spray/load and the dative alternations	192
4.1	Introduction	192
4.1.1	The linguistic context	193
4.1.2	Animacy and referring expressions	194
4.1.3	Phonological weight	195

4.1.4	Number	196
4.1.5	Definiteness, definite and indefinite articles	197
4.2	Method	200
4.2.1	Participants	200
4.2.2	Materials and procedure	200
4.2.3	Sentences tested	201
4.3	Results	205
4.3.1	Group Comparisons	205
4.3.2	Individual comparisons	207
4.4	Discussion	209
4.5	Chapter summary	212
CHAPTER 5	The effect of the egocentric perception of distance on preferences in the spray/load and dative alternations	213
5.1	Introduction	213
5.1.1	The visual context	215
5.1.2	Colour	216
5.1.3	Novelty and surprise	217
5.1.4	Animacy and visual attention	218
5.2	Method	219
5.2.1	Participants	219
5.2.2	Materials and procedure	219
5.2.3	Images	221
5.2.4	Sentences tested	222
5.2.5	Fillers and practice items	225
5.2.6	Results	226
5.2.6.1	Group comparisons	227
5.2.7.2	Individual and between group comparisons	232
5.8	Discussion	234
CHAPTER 6	The analysis of the spray/load and dative alternations	236
6.1	Introduction	236
6.2	Key points	237
6.3	The analysis of the spray/load alternation	242
6.4	Distinguishing hierarchical from linear assembly: Merge versus online production	244
6.5	Areas for future research	248
6.5.1	Accounting for the variable presence of <i>with</i> in the <i>with</i> -variant and double-object constructions.....	248
6.5.2	Unifying double-complement alternations	256
6.5.3	Aligning grammatical theory and language processing	257
6.6	Summary and final remarks	258
Bibliography	261
Appendices	287
Appendix 1	Baseline survey	287
Appendix 2	Experiment 1 data – spray/load alternation responses	290
Appendix 3	Experiment 1 data – dative alternation responses	291

Appendix 4	Experiment 2 data: spray/load alternation responses	292
Appendix 5	Experiment 2 data: dative alternation responses	293
Appendix 6	Post-experiment information for participants in experiment 1.....	294
Appendix 7	Examples of visual stimuli for experiment 2.....	295

List of Figures

Figure 1.	Critical trial verbs and their matched referring expressions	201
Figure 2.	Frequency list of verbs by lemma: occurrences per million	203
Figure 3.	Total number and percentage of responses in the spray/load alternation	206
Figure 4.	Total number and percentage of responses in the dative alternation	207
Figure 5.	Total number and percentage of individual preferences for a construction from the spray/load alternation	208
Figure 6.	Total number and percentage of individual preferences for a construction from the dative alternation	209
Figure 7.	An example of the four critical trial image variants	222
Figure 8.	Frequency list of verbs by lemma: overall occurrences per million	223
Figure 9.	Critical trial verbs and their matched referring expressions	224
Figure 10.	An example of four variants of a filler trial	225
Figure 11.	Number and percentage of locative and with-variant responses in condition 1	227
Figure 12.	Number and percentage of locative and with-variant responses from condition 2	228
Figure 13.	Comparison of with-variant responses from condition 1 and 2	229
Figure 14.	Number and percentage of dative and double-object construction responses from condition 1	230
Figure 15.	Number and percentage of dative and double-object construction responses from condition 2	230
Figure 16.	Comparison of double-object responses from condition 1 and 2	231
Figure 17.	Total number and percentage of overall individual preferences in condition 2 for the spray/load alternation	232
Figure 18.	Total number and percentage of overall individual preferences in condition 2 for the dative alternation	233

List of Tables

Table 1.	Spray/load alternating verbs in Levin (1993)	7
Table 2.	Dative alternating verbs in Levin (1993)	9

Chapter 1. Background

1.1. Introduction

This thesis investigates double-complement alternations, with a view to providing a first comprehensive analysis of the spray/load alternation as presented in (1).

- (1) a. Sarah will load luggage onto aeroplanes.
b. Sarah will load aeroplanes with luggage.

The spray/load alternation is one of the so-called Locative groups of argument alternations (Fillmore, 1968). As can be seen in (1a) and (1b), the constructions in the spray/load alternation differ in the word order of their grammatical objects as well as in the accompanying prepositional material. Previous analyses of the constructions in the spray/load alternation have focussed chiefly on their semantic interpretation (e.g. Partee, 1965; Anderson, 1971; Goldberg, 1995; Beavers, 2006). The purpose of this thesis is to provide a more comprehensive analysis of the alternation in terms of its syntactic structures and to examine how contextual information can drive the direction of the word order of arguments. With respect to syntax, the structure of the spray/load alternation has received far less attention than another double-complement construction, namely the dative alternation, as illustrated in (2).

- (2) a. Sarah will feed the zebra to the lion.
b. Sarah will feed the lion the zebra.

Throughout this thesis, the constructions involved in the spray/load alternation are examined against the constructions involved in the dative alternation. What I aim to show is that the dative alternation structures parallel those in the spray/load alternation; specifically that (1a) matches (2a), and (1b)

matches (2b). This will be achieved by providing a range of standard syntactic tests that are used to reveal a sentence's syntactic structure. Contemporary analyses of the spray/load alternation tend to view the alternation as semantically driven, in the sense that the sentences in (1a) and (1b) describe different yet related events. However, we will see that predictions made by these approaches do not consistently account for the data. It is as yet unclear whether and what additional factors contribute to the selection of either (1a) or (1b). I intend to bring new evidence to bear on this issue and provide some additional answers as to the motivation for the alternation. It will be shown that context, specifically visual context, is a driving force. The contextual variable that will be introduced is the egocentric perception of distance, which has not previously received attention in the literature on object order differences. On the basis of two experiments, it will be argued that preferences for one or other of the constructions in both the spray/load and dative alternations are sensitive to this variable. Together with the syntactic tests to be presented, these experimental results not only provide a more fine-grained analysis of the spray/load construction but also show that a purely semantic account of the constructions in (1) cannot provide a complete analysis. Specifically, these approaches cannot account for the effect of contextual motivations.

This thesis will use the base-generated theory of Janke and Neeleman (2012) for the structures of the spray/load alternation in (1) and the dative alternation in (2). I show the structures that represent the constructions in the spray/load alternation are essentially the same as the structures that underlie the constructions in the dative alternation. This base-generated account will be argued to be advantageous as it provides a means of capturing real-time structure-building processes which are influenced by the effects of context, particularly the way that visual information is processed (Posner and Peterson, 1990) and reported (Myachykov et al., 2011).

This chapter provides a general introduction to alternations in double-complement structures, before moving on to the spray/load and dative alternation in particular. I first provide the relevant terminology to be used throughout the thesis so that the constructions in the spray/load and dative alternations can be clearly distinguished. Having set out the terminology, an initial observation of the surface properties of these constructions will be given. A list of the verbs that are said to take part in the spray/load alternation and the dative alternation will follow, as it is from this set that the many of the subsequent examples to be analysed and tested are taken. I then discuss the thematic structure of the constructions. Some specific issues of the spray/load alternation will naturally arise from this first description and these will be highlighted for further discussion. To begin, I describe what is meant by an alternation.

1.2. What is an alternation?

An alternation is a term that is used to describe a verb or class of verbs that seem to participate in more than one subcategorisation frame. A subcategorisation frame manifests as a distinct sentence construction in which the verb's arguments appear in a particular linear order. A different subcategorisation frame will have arguments that appear in a different linear order. Each distinct construction will be referred to as a variant. This is illustrated in (3) with the distinction between the active and passive voice, and in (4), which shows the so-called *swarm* alternation. Here we see a difference in terms of which argument functions as the sentential subject.

- (3) a. The dog chased the man.
 $\exists e(\text{chase}, e) \wedge \text{AGENT}(\text{the dog}, e) \wedge \text{PATIENT}(\text{the man}, e)$
- b. The man was chased by the dog.
 $\exists e(\text{chase}, e) \wedge \text{AGENT}(\text{the dog}, e) \wedge \text{PATIENT}(\text{the man}, e)$
- (4) a. The bees swarmed in the garden.
 $\exists e(\text{swarm}, e) \wedge \text{AGENT}(\text{bees}, e) \wedge \text{AT}(\text{the garden}, e)$
- b. The garden swarmed with bees.
 $\exists s(\text{swarm with bees}, s) \wedge \text{In}(\text{the garden}, s)$

The examples in (3) exhibit the same underlying meaning for each of their variants as shown by their semantic representation. In (3) the difference is usually said to be a difference in emphasis between the arguments in the sentence. In (3a) it is *the dog* which is emphasised, whereas in (3b) it is *the man*. In (4) however, there is a semantic difference in the kind of event that is described, as shown by their distinct semantic representations. In (4a) *the bees* are the actors in a swarming event, whereas in (4b) the swarming (*with bees*) is a predicate that describes a complex property of *the garden* (cf. Dowty, 1999, 2000, 2001). I now turn to verbs that select a double-complement which exhibit an alternation of their object arguments before looking specifically at the spray/load and dative alternations.

1.3. What is a double-complement alternation?

These are the alternations of concern to this thesis, particularly the spray/load alternation in (5) and the dative alternation in (6). They are called double-complement constructions because they obligatorily select two complements. At a purely descriptive level, the constructions introduced in (5) and (6) are classified as double-complement alternations on the basis of their exhibiting a difference in the linear order of their object arguments, whereas the verbs and the sentential subjects are not altered.

- (5) a. John sprayed the paint onto the wall.
b. John sprayed the wall with the paint.

(The spray/load alternation)

- (6) a. Bill sent the letter to Mary.
b. Bill sent Mary the letter.

(The dative alternation)

So far, we have only seen what a spray/load alternation and a dative alternation is. We now turn to the properties of each of the constructions in the spray/load and dative alternations. Our first step will be to classify the complements after which we can begin with a more detailed description of each of the constructions.

1.4. Properties of double-complement structures

Before we can proceed, the objects in these sentences require labelling. Traditionally the complements in a double-complement structure have been referred to as a direct object and an indirect object.¹ However, I shall identify the two complements in a double-complement structure as NP1 and NP2. This is purely descriptive labelling, the aim of which is to abstract away from problems with the classification of grammatical labels (cf. Perlmutter and Postal, 1977; Chomsky, 1981; Perlmutter, 1983; Hoekstra, 1984; Williams, 1984; and especially Herriman and Seppänen, 1996). The kind of labelling in (7) is common (e.g. Barss and Lasnik, 1986; Larson, 1988; Bruening, 2001; Larson, 2014; Levin, 2014; a.o.) Here, NP1 corresponds to the objects in (7) that immediately follow their verb, and NP2 corresponds to the objects embedded in the locative preposition (as indicated with subscript). The argument that corresponds to the subject is not of direct concern; we are chiefly interested in the internal arguments of the verb phrase (VP). As such I shall follow convention by referring to this argument as *subject* throughout.

- (7) a. David passed the ball_{NP1} to John_{NP2}.
b. John loaded the boxes_{NP1} onto the truck_{NP2}.

In order to maintain consistency when describing the complements of a double-complement structure, the argument that is marked as NP1 in a sentence like (7a) will still be described as NP1 in a sentence like (8) even though its linear position has changed; it no longer immediately follows the verb. Similarly, the argument that corresponds to NP2 in (7a) will also be described as NP2 in (8), even though this argument now appears in the immediate post-verbal position.

- (8) David passed John_{NP2} the ball_{NP1}.

¹ These are notoriously difficult terms to define without resort to semantic definitions (e.g. Huddleston and Pullum, 2005; Mathews, 2007; Radford, 2004).

Just as with the double-complement structures, the argument that is marked as NP1 in a sentence like (7b) will still be described as NP1 in a sentence like (9). Similarly, the argument that corresponds to NP2 in (7b) will also be described as NP2 in (9). In this way, we avoid the problem of labelling *the boxes* in (7b) as a direct object, and in (9) as an indirect object. Using the direct and indirect object labels for this argument in spray/load constructions is based on semantic criteria (i.e. the argument that is most *affected* by the verb is the direct object argument. See Baker (1997), a.o.), which is undesirable for determining the syntactic structure².

(9) John loaded the truck_{NP2} with the boxes_{NP1}.

Having clarified the labels for the arguments in these constructions, we can, at a purely descriptive level, distinguish between the constructions introduced in (5) and (6) on the basis of the linear order of their object arguments. We will then move on to describe the constructions individually.

1.5. The spray/load alternation

We saw that the sentences in (5) demonstrated the so called spray/load alternation (e.g. Levin, 1993). This refers to a construction whose main verb's complements can occur in one of two possible orders as illustrated in (10).³

- (10) a. John loaded [the hay]_{NP1} [onto the wagon]_{NP2}. (LOCATIVE VARIANT)
 b. John loaded [the wagon]_{NP2} [with the hay]_{NP1}. (WITH VARIANT)

² The labelling that I use does imply a theoretical perspective in that the two constructions in the spray/load alternation are not distinct in the kind of event that the constructions describe.

³ This alternation is often classed as a locative alternation because it exhibits a difference in the location of the so called *locatum* argument – the entity whose location is described by the verb (Clark and Clark, 1979).

In (10a), NP2 appears with the preposition *onto*⁴ and follows NP1. This construction is referred to as the *locative*-variant (e.g. Clark and Clark, 1979). In (10b), NP2 precedes NP1 and appears without a preposition. NP1 now appears with the preposition *with*. As such, this construction is referred to as the *with*-variant construction (e.g. Laffut and Davidse, 2002; Iwata, 2008). Note that, in these constructions, one of the arguments is always embedded in a preposition. This is important for accounts of the structure of the spray/load alternation because the Verb + NP + PP order for both of the variants has been taken as indication that they have identical structures (e.g. Hale and Keyser, 1996). For now, we will say that the variability lies with which of these arguments is embedded in the preposition, and the different orders of the complements. Table 1 presents a list of verbs compiled by Levin (1993) that take part in the spray/load alternation. Each of the verbs is compatible with both of the constructions in (1).

Table 1. Spray/Load Alternating Verbs (Levin, 1993)

Brush, Cram, Crowd, Cultivate, Dab, Daub, Drape, Drizzle, Dust, Hang, Heap, Inject, Jam, Load, Mound, Pack, Pile, Plant, Plaster, Pump, Rub, Scatter, Seed, Settle, Sew, Shower, Slather, Smear, Smudge, Sow, Spatter, Splash, Splatter, Spray, Spread, Sprinkle, Spritz, Squirt, Stack, Stick, Stock, Strew, String, Stuff, Swab, Wrap.

1.6. The dative alternation

The sentences in (6) demonstrated the so-called dative alternation (e.g. Oehrle, 1976). From a linear perspective, in (6a), the verb is followed immediately by NP1 after which appears NP2, which is

⁴ Other locational prepositional material can also appear in this construction such as *on*, *in*, and *into*.

- (i) a. John laid the cutlery onto the tables.
b. John laid the tables with the cutlery.
- (ii) a. John packed fruit into boxes.
b. John packed the boxes with fruit.
- (iii) a. John planted cabbages in the field.
b. John planted the field with cabbages.

embedded in a prepositional phrase. In contrast in (6b), the unembedded NP2 immediately follows the verb and NP1 comes immediately after.

The reason these constructions are referred to as the dative alternation has to do with the embedding of NP2 in a prepositional phrase in one of the constructions. The term *dative* is used to describe a property of the object headed by the preposition. This is usually shown by a specific declension in many Germanic and Romance languages known as dative case morphology. However, in present day English, Dative Case morphology has been virtually lost (see van Belle and Langendonck, 1996 for a discussion on the dative). This is illustrated in (11), which shows that dative morphology is still present for some speakers on the dative *wh*-word *whom*⁵, but is lost on other dative NP expressions.

11. a) John gave (the flowers)_{ACC} (to Mary)_{DAT}
b) John gave (them)_{ACC} (to whom)_{DAT}?
c) John gave (them)_{ACC} (to who)_{DAT}?

The example in (12) illustrates the dative alternation again. This will enable us to label the alternates individually. In (12a), NP2 follows NP1, and is also embedded in the prepositional phrase. On this basis it is referred to as the dative construction (Czepluch, 1982). In (12b) NP2 precedes NP1 and appears with no prepositional material. As such this construction is usually referred to as the double-object construction (e.g. Larson, 1988).

12. a) John gave the flowers to Mary. (DATIVE CONSTRUCTION)
b) John gave Mary the flowers. (DOUBLE-OBJECT CONSTRUCTION)

Table 2 presents a list of verbs compiled by Levin (1993) that take part in the dative alternation. Each of the verbs is compatible with both of the constructions in (2).

⁵ This is also referred to as *oblique* case.

Table 2. Dative Alternating Verbs in Levin (1993).

GIVE VERBS	Feed, Give, Lease, Lend, Loan, Pass, Pay, Peddle, Refund, Render, Rent, Repay, Sell, Serve, Trade.
VERBS OF FUTURE HAVING	Advance, Allocate, Allot, Assign, Award, Bequeath, Cede, Concede, Extend, Grant, Guarantee, Issue, Leave, Offer, Owe, Promise, Vote, Will, Yield.
BRING AND TAKE	Bring, Take.
SEND VERBS	Forward, Hand, Mail, Post, Send, Ship, Slip, Smuggle, Sneak.
SLIDE VERBS	Bounce, Float, Roll, Slide.
CARRY VERBS	Carry, Drag, Haul, Heave, Heft, Hoist, Lug, Pull, Push, Schlep, Shove, Tote, Tow, Tug.
VERBS OF THROWING	Bash, Bat, Bunt, Catapult, Chuck, Flick, Fling, Flip, Hit, Hurl, Kick, Lob, Pass, Pitch, Punt, Shoot, Shove, Slam, Slap, Sling, Throw, Tip, Toss.
VERBS OF TRANSFER OF MESSAGE	Ask, Cite, Preach, Quote, Read, Relay, Show, Teach, Tell, Write.
VERBS OF INSTRUMENT OF COMMUNICATION	Cable, Email, Fax, Modem, Netmail, Phone, Radio, Relay, Satellite, Semaphore, Sign, Signal, Telephone, Telecast, Telegraph, Telex, Wire, Wireless.

Having now identified the order of arguments within these constructions and their accompanying labels, we move on to describe another key characteristic, which is the constancy of the theta-roles assigned to their arguments. This is important because later we will see that some theories that have attempted to derive an account of these constructions have used the presence of constant theta roles to argue that one construction in an alternation is derived from the other, whereas others have argued that the theta-roles are different for each construction and so one is not derived from the other.

1.7. Thematic roles

A consistent property of both the dative and spray/load alternations is the thematic roles of their arguments. Thematic roles express the semantic relations that arguments in a construction bear toward the action denoted by the verb (see Gruber, 1965; Fillmore, 1968; Jackendoff, 1972). For example, in the declarative sentence in (13) we see that the sentence expresses an event where the subject, *John* is the instigator of the action of reading. This makes John the *agent* of the action, and as such it has the *agent* thematic role in the sentence. The object, *a book*, is the argument that undergoes the action expressed by the verb, but whose state is not changed. As such, this thematic role is usually called a *theme*. In (14), the subject *John* is still the *agent* of the action, but now the object *work* embedded in the prepositional phrase (PP) expresses the locational endpoint or target of the action denoted by the verb. As such this argument is referred to as having a location thematic role called a *locative*. The subject of a sentence is not always an *agent*, however. This is demonstrated in (15) in which *John* is no longer an *agent* as he is not the instigator of the action denoted by the verb. He is now receiving a *theme* (a book). The thematic role associated with an argument that receives something denoted by the verb is called a *recipient*⁶. The roles are indicated in the examples (13-15) by subscripts.

(13) John_{AGENT} read a book_{THEME}.

(14) John_{AGENT} walked to work_{LOCATIVE}.

(15) John_{RECIPIENT} received a book_{THEME}.

In respect to the thematic roles of the dative alternation and spray/load alternation in (16) and (17) respectively, one view is that the thematic roles of the objects remain consistent across the alternation. The roles are not affected by either the word order of the arguments nor the presence or variety of prepositional material accompanying the arguments (e.g. Bresnan et al., 2007). On this view, in both (16a) and (16b) *John* is an *agent* as he instigates the action, and *the book* is a *theme* as it undergoes the action expressed by the verb, while *Mary* is the *recipient* as she is receiving *the book*. In both (17a) and (17b) *John* is an *agent* as he instigates the action, *dirt* is the *theme* as it undergoes

⁶ I only include these roles as they are the ones commonly associated with the spray/load and dative alternations. However, many different roles have been proposed.

the action expressed by the verb, and *the window* is the *locative goal* as it expresses the target of the action denoted by the verb⁷.

16. a) John_{AGENT} gave the book_{THEME} to Mary_{RECIPIENT}.
b) John_{AGENT} gave Mary_{RECIPIENT} the book_{THEME}.
17. a) John_{AGENT} smudged dirt_{THEME} on the window_{LOCATIVE}.
b) John_{AGENT} smudged the window_{LOCATIVE} with dirt_{THEME}.

The classification in (16) and (17) is contested (e.g. Pinker, 1989; Gropen et al., 1991; Goldberg, 1995). Rather than the NP2 argument in each variant being associated with the same theta label, each NP2 is associated with its own distinct thematic label. In (16b) *Mary* is claimed to be a *possessor* whereas in (16a) *Mary* is an intended *recipient* as illustrated in (18). Similarly in (17a), NP1 is a *theme* as it is wholly affected by the action and NP2 has the *locative* role, whereas in (17b), NP2 is a *theme* as it is argued to be wholly affected by the action in this construction, and NP1 now has a role akin to an instrument or medium that facilitates the action (e.g. Goldberg, 1995). This is illustrated in (19).

18. a) John_{AGENT} gave the book_{THEME} to Mary_{RECIPIENT}.
b) John_{AGENT} gave Mary_{POSSESSOR} the book_{THEME}.
19. a) John_{AGENT} smudged dirt_{THEME} on the window_{LOCATIVE}.
b) John_{AGENT} smudged the window_{THEME} with dirt_{MEDIUM}.

⁷ Other semantic roles are possible for events described by double-complement structures, such as *experiencer* (someone who is experiencing some psychological state) in (i), and *benefactor* (a positively affected entity) in (ii).

- (i) Will_{AGENT} showed the painting_{THEME} to Helen_{EXPERIENCER}
(ii) Aron_{AGENT} rented the house_{THEME} to Tom_{BENEFACTOR}

Which particular approach to thematic labelling is taken is dependent upon how one views the semantic and syntactic structure of the constructions in the alternation. This will become apparent in chapter 2 where a review of the literature is presented.

In this introductory chapter, I have presented the spray/load alternation alongside the dative alternation and have shown that in each of the alternations there are two constructions that differ in the word order of their complements and the kinds of prepositional material that can accompany them. Objects that appear in the constructions are labelled as NP1 and NP2. Each variant of the alternations were given individual labels. Those in the spray-load alternation were labelled as a locative variant construction and a *with*-variant construction, and those in the dative alternation were called the dative construction and the double-object construction. It was also seen that each object is associated with a thematic role but that there are two opposing views to this: either the roles remain consistent across the alternation, or there is a specific set of roles for each construction in an alternation.

Having established the conventional terms used to describe the constructions and the elements within them, I now move to chapter 2 where I begin with the view of thematic structure proposed in Reinhart (2000; 2002). The purpose of this is to establish the kind of information that is visible to the syntax and how this is ultimately represented in the syntactic structure. We then turn to a syntactic account of double-complement structures given in Janke and Neeleman (2012), which will provide the framework against which the two alternations are compared. After establishing the structure of double-complements, we move the discussion onto the semantic account of the spray/load and dative alternation as given by Goldberg (1995). This account will be shown to be problematic in a number of ways. An argument will then be presented such that context can affect the word order of arguments in the spray/load and dative alternation. I provide a view of how contextual information interacts with sentence formation based on our limited capacity to process information (e.g. Ferreira and Dell, 2000; Slevc, 2011; a.o.). In this section, I also identify a variable of the visual context whose effect has so far not been tested on the word order of the spray/load and dative alternations – the egocentric perception of distance. Chapter 3 builds on the syntactic account introduced in chapter 2 by utilising a number of tests known to be sensitive to syntactic structure. We will see that the outcome of these tests suggest that the variants in the spray/load alternation in fact have the same distinctive structures as those available in the dative alternation. Specifically the locative variant construction has the same structure as the dative construction, and the *with*-variant construction has the same structure as the double-object construction. Chapters 4 and 5 form the experimental part of the thesis. In chapter 4, a survey demonstrates that there is a default preference for the locative construction in the spray/load

alternation and for the dative construction in the dative alternation in the absence of context. This forms an important precursor to the experiment in the following chapter as it provides a baseline preference against which the effect of the egocentric perception of distance can be measured. Chapter 5 describes an experiment using a picture-sentence matching task the results of which demonstrate that participants' preferences can be significantly affected by the egocentric perception of distance. This shows that the preference for a particular argument order in the spray/load and dative alternations is influenced by a non-semantic feature of the visual context. Chapter 6 elaborates on the data presented and an argument is formed such that the selection of a variant from the spray/load alternation is not semantically motivated but rather is affected by the context. I also argue that the view of the thematic structure and the syntax given here is compatible with how our information processing system is constrained by its limited capacity. We end the thesis in chapter 6 with the implications of my account for the language system in general and the identification of further areas of research before I make some final remarks.

Chapter 2. Literature Review

2.1. Theta roles and argument structure

Since much of the focus of this work is the motivation behind the word order differences in the spray/load alternation, it is important to begin our discussion with a consideration of the contribution of theta roles to argument structure. Theta roles are properties attributed to a particular predicate. The predicate may be a verb, adjective, preposition, or a noun. As this thesis is concerned with argument structure, discussion is limited to the relation of verbs and theta roles. In what follows, I begin with a description of the conditions that appear to hold of theta roles. I then describe the relation between syntactic position and types of theta roles in the context of the Thematic Hierarchy. In (2.4), I focus on the thematic hierarchy and show that its formulation is problematic for most accounts. This is not new but serves as a background to the analysis of semantic accounts of double-complement alternations in general and the spray/load (and dative) alternation in particular. These accounts rely on fine-grained distinctions of theta roles. I concentrate discussion predominantly on the distinction between *recipient* and *possessor*, and between *goal*, *location* and *recipient*, and I will base analyses on the structure of the theta system proposed in (Reinhart, 2000; 2002). In this system, theta roles are not distinct primitive labels such as *recipient*, but are rather sets of binary features. Any thematic label is therefore inferred by the semantics (modulo context) rather than projected from some lexical entry of a verb. We will encounter an outline for this account in (2.6). I make three claims about theta roles based on this system which has consequences for subsequent analyses in this thesis. Firstly in (2.6.1), I claim that the theta roles *goal*, *location* and *recipient* are not distinct; they share the same theta cluster, and should therefore have identical projections into the syntax. It will be demonstrated that only animacy can distinguish these roles. I go on to argue that animacy is not a primitive feature of the Theta System; it can only be inferred or contextually determined. The consequence of this is that the thematic structure of the spray/load alternation that is relevant to syntactic structure is identical to the dative construction. This is important for later discussion about the syntactic structure of the spray/load alternation. It supports the view that the structures of the spray/load alternation are identical to those of the dative alternation. Secondly, in (2.6.2), I show that there is no difference between the theta roles of *recipient* and *possessor* in respect to what the syntax is sensitive to. This has consequence for semantic accounts of both the dative and spray/load alternations that rely on differences in theta roles to account for apparent differences in meaning. Identical theta grids are specified for both the dative and double-object constructions of the dative alternation, and the locative variant and *with*-variant constructions of the spray/load alternation. This

is relevant as it means that factors that exist aside from the thematic specification in the lexicon must trigger the word order differences found in those alternations. My last claim in (2.9) is that that a hierarchy of features does exist in the Theta System. I assert that the distribution of theta clusters along a hierarchy is uniform. I propose a Thematic Feature Hierarchy in which feature clusters are uniformly distributed. In the hierarchy, the feature cluster that corresponds to a *theme* interpretation is the lowest cluster on the hierarchy. It is realised as an internal argument when any other feature cluster is present. I also claim that linear flexibility of the feature cluster that corresponds to a *recipient/goal/location* interpretation is not a consequence of varying positions along the hierarchy. I argue that the values of features in a feature cluster orders the clusters and means that the feature cluster that corresponds to a *recipient/goal/location* interpretation must occur uniformly in a position higher than the feature cluster that corresponds to a *theme*. I make the claim that this can only happen if hierarchical superiority is specifically structurally based. This means that any difference in linear order between these arguments is caused from non-thematic influences. To commence the discussion, I begin with describing the conditions on theta role assignment.

2.2. Conditions on theta role assignment

Classically, theta roles are thought to contain semantic information that can identify the roles that participants play in an event described by a verb (e.g. Fillmore, 1968). Some commonly assumed thematic roles are *agent*, *cause*, *theme*, *recipient*, and *instrument* among others (cf. Jackendoff, 1972). These roles are usually assigned to a verb's arguments. This means that a verb contains information in its lexical entry that subcategorises for the number of arguments that it must appear with, and specifies the type of role that those arguments can be assigned. It is clear then that the relation of theta roles and argument structure is relevant to the interface between syntax and semantics. The following examples help to illustrate this. The transitive verb *pick* obligatorily selects two arguments as can be seen in (20).

- (20) a. John picked the lottery numbers.
b. *John picked.
c. *picked lottery numbers.

A transitive verb like *pick* assigns two participant roles to its arguments: a picker (the *agent*) and the thing that is being affected by the action (the *theme*) as illustrated in (21). These roles are uniquely mapped onto the two arguments; *John* and *the lottery numbers* respectively.

(21) (John)_{AGENT} picked (the lottery numbers)_{THEME}.

It is not possible for the two roles of the predicate to be assigned to the same referring expression. In (20a) *John* cannot simultaneously be the *agent* and the *theme*, even though this is a possible state of affairs for the referent of *John*. For example, in (22a) there is a co-relation between *John* and *himself* in the fact that they refer to the same referent. In this case, the referent of *John* is the *agent* and the referent of *himself* (which is the same as the referent of *John*) is the *theme*. Even though there is a co-reference between *John* and *himself*, they are still distinct syntactic arguments – a subject and an object.

- (22) a. John picked himself.
b. *John picked.

It is impossible for an argument of a verb not to be assigned a theta-role.

(23) *John dreamed Mary.

The verb *dream* has only one theta role to assign – the experiencer of the dreaming – and this role is assigned to *John*. The argument *Mary* therefore ends up with no role. So it is clear that a relation exists between the number of theta-roles assigned and the number of arguments that are selected by the

verb⁸. Multiple theta roles that are specified by a verb cannot be assigned to the same argument of its predicate, and every argument of the verb must be assigned one of the verb's theta-roles. Many attempts have been made to formally define this relation (e.g. Chomsky's (1981) Theta Criterion; Broadwell's (1986) Revised Theta Criterion), but these attempts have failed to effectively capture all the behaviour of theta-assignment (cf. Marelj, 2004 for a review). What is consistently maintained in the literature (e.g. Bošković; 1994; Lasnik, 2000) is that all the available theta roles of a verb must be assigned to the verb's arguments, and that each argument of a verb has only one theta-role specified by that verb assigned to it.

2.3. Uniqueness

A further restriction was specified by Bresnan (1982a), Parsons (1990), and Carlson (1998) in that each theta role specified by a verb must be unique; it must have a unique function in respect to the other theta roles specified by the verb. This means that an event can have at most one *agent*, one *theme*, one *goal* and so on. The participants in an event are related to that event by distinct thematic relations. "Suppose we were to label [...] both the direct and the indirect objects [with the same role]. Then, the logical form of a sentence containing both such items would be logically equivalent to the sentence with the direct and indirect object interchanged. If you gave a fish to Mary, you would thereby give Mary to a fish." (Parsons, 1990: fn. 5: p.293).

⁸ Jackendoff (1987) claims that there exist cases in which an NP argument receives more than one theta-role. Such cases occur in verbs like *sell*, *trade*, *buy*, and *exchange*. For instance, the verb *sell* involves at least two components to the event.

- (i) X sells Y to Z.
 - a. Y changes possession from X to Z.
 - b. Money changes possession from Z to X.

However, although the exchange of money is a necessary condition for the completion of a selling event, there is only the inference that the exchange of money has taken place at that time.

- (ii) a. John sold the car to Mary. She will pay him next month.
 - b. John will sell a car to Mary.

2.4. Syntactic restrictions on theta-assigned arguments

The sentence position in which these arguments appear is also crucial. The *agent* – defined as ‘the doer who is also responsible for what is done’ (Parsons, 1990) – of the picking event in (20a) can only appear in the sentence subject position and the thing that is being picked can only appear in the object position as (24) illustrates. In (24), the only possible reading is where *the lottery numbers* is the *agent* of the picking and *John* is the participant being picked.

(24) ??The lottery numbers picked John.

The apparent restriction on the type of theta-role that can appear in a certain position in the presence of other theta-roles has led to the assumption that theta roles are ordered into a hierarchy with repercussions in the syntax. Their underlying syntactic order is predicted from their position in a ‘Thematic Hierarchy’ where the relational status between theta roles has consequence for their underlying positions in the syntax (especially Baker (1988) and Larson (1988)). It is to this that we now turn.

2.5. The ‘Thematic Hierarchy’

On the thematic hierarchy, theta roles are ranked relative to one another in terms of superiority. The relative ranking has consequences for structural positions in the syntax. In a transitive sentence, the theta role that is ranked as superior to the other will appear as the subject. For example, the verb *open* can appear with a number of possible theta-roles in the subject position. Each available role possibility occupies this position over a *theme* as illustrated in (25). This means that in the Thematic Hierarchy, the *theme* role must be ranked lower than an *agent*, an *instrument*, or a *cause* as it cannot appear as the subject when any of these other roles are present. The *theme* can only appear as the subject when there are no other roles selected by the verb (25d).

- (25) a. John (*agent*) opened the window (theme).
 a'. *The window opened John.
 b. The key (*instrument*) opened the window (theme).
 b'. *The window opened the key.
 c. The wind (*cause*) opened the window (theme).
 c'. *The window opened the wind.
 d. The window opened.

Although the sentence position of *agents* relative to other theta roles tends to be predictable – the *agent* will always appear as the subject of an active transitive sentence – predictions about the relationship between other types of theta roles and sentence positions have proved more problematic. A case in point is the alternations examined in this thesis. In (26) the verb *load* selects three arguments and three theta roles. In (26a) the roles are an *agent* (a doer of the action), a *theme* (the thing being directly affected by the action), and a *goal* (the target that the affected theme moves toward). The *agent* is always the default sentence subject. In respect to the *theme* – that which is chiefly affected by the event (Baker, 1996) – we can see in (25) and (26), that it regularly appears as the direct object. This means that *the boxes* in (26a) syntactically qualifies as the *theme*. However, in (26b) the sentence position of *the boxes* is different.

- (26) a. Tom loaded the boxes onto the truck.
 b. Tom loaded the truck with the boxes.

This can only be explained by proposing that either *the boxes* has a different theta-role in each of the constructions (e.g. Baker, 1997), or that both constructions have the same theta roles in their underlying structure but are distinguished by transformational processes that change the position of

the arguments (e.g. Speas, 1990; Damonte, 2005)⁹. In the case of the former explanation, a difference in thematic roles assigned by a verb has consequences for the meaning of the event described by the two sentences in (26) – a different thematic grid means a different event. As we shall see in (2.15) this forms an integral part of semantic approaches of the spray/load alternation. For the latter explanation, a similar meaning between the two constructions in (26) is maintained, but a trigger for the difference in word order is lacking.

There exist a number of formulations of thematic hierarchies. They show disagreement in both the hierarchical ordering of theta roles as well as the type of theta roles that exist or are relevant. Rappaport Hovav and Levin (2004) compiled a list of 8 distinct thematic hierarchies; shown in (27). The theta roles to the left are claimed to be superior to the theta roles on their right. Roles separated by a slash are considered to be ranked together.

- (27) a. Agent > Theme/Patient > Goal/Source/Location (Baker,1997)
- b. Agent > Experiencer > Theme (Belletti and Rizzi, 1988)
- c. Agent > Benefactive > Recipient/Experiencer > Instrument > Theme/Patient > Locative (Bresnan and Kanerva, 1989)
- d. Agent > Patient > Receiver > Benefactor > Instrument > Locative (Dik, 1978)
- e. Agent > Experiencer > Instrument > Patient > Goal/Source/Location (Fillmore, 1971)
- f. Agent > Dative/Benefactive > Patient > Locative > Instrument/Associative > Manner (Givón, 1984)
- g. Agent > Patient/Benefactive > Theme > Goal/Source/Location > Benefactive (Jackendoff, 1990)
- h. Agent > Effector > Experiencer > Locative > Theme > Patient (Van Valin, 1990)
- (Rappaport Hovav and Levin, 2004: 2. Their 1.)

⁹ In these accounts, the difference in word order ultimately has an effect on the semantics of the event described by the sentence.

As can be seen by the diverging hierarchies in (27), the classification of theta-roles in terms of fully specified participant roles is problematic. Levin and Rappaport Hovav (2005) observe that a unique, universally attested set of theta roles has been elusive. Capturing the linking rules that tie fully specified participant roles and syntactic position has been equally problematic (Everaert, Marelj, and Siloni, 2012). The regularity of linking *agents* to sentence subjects is not mirrored in other roles to other syntactic positions. Dowty (1991) sees this problem being a focus on finer characterisations of roles in order to capture some distinction, with the consequence that generalisations across roles are missed. Reinhart (2000; 2002) claims that such a fine characterisation is not legible to the syntax; instead she proposes a system that identifies theta roles as the coding of two binary feature specifications. These features are visible to both the syntax and the semantic inference systems. In this system a theta role is a feature cluster not a fully specified semantic role. Any distinguished participant role such as *recipient* or *agent* is an inference based on the values of the feature cluster (modulo context). It is to this system that we now turn.

2.6. The Theta System

Reinhart (2000) follows a modular approach to language. Language is organised as a set of task specific systems. The theta system is the central component of the mental system that enables the interface between the system of concepts and the computational system (the syntax). Its outputs are the inputs into the syntax, and these outputs are also legible to the inference, context, and sound systems. The Theta System contains coded concepts (lexical entries) with features that define the basic theta-relations of verb entries (causality and sentience), and a set of marking procedures that prepare verbal material for the syntax. In order to be visible to both the syntax and the inference systems, the outputs of the theta system are formally coded. The coding of theta relations are proposed to be a set of two binary features: $+/-c$ (cause change), and $+/-m$ (mental state). This means that a theta-role is not a primitive of the Theta System, but rather it is a semantic label inferred from the decomposition of its feature specification (its feature cluster). (28) provides the notational convention used for the Theta System.

(28) *Notation*

[α] = Feature cluster α .

/ α = Feature (and value) α . (E.g. the feature /+m occurs in the clusters [+c+m], [-c+m], and [+m])

[/ α] = A cluster one of whose features is / α . (E.g. [/-c] clusters are [-c+m], [-c-m] and [-c].)

[+] = A cluster all of whose features have the value +.

[-] = A cluster all of whose features have the value -.

(Reinhart , 2002)

The /c feature determines whether the argument is causally responsible for causing the event described by the verb. A positive value /+c is associated with roles such as *agent*, *cause*, and *instrument* as they are causal to the event. The difference between *agent* and *cause* revolves around whether it is relevant to the event whether the cause was volitional or intentional. The /+m value is associated with an awareness of the event. The cluster [+c +m] represents a participant who is aware that he is causing the event. An awareness of one's actions entails the sentience of the participant, and therefore the cluster [+c +m] is inferred to be an animate causer – an *agent*. The underspecified [+c] cluster is unspecified for the participant's mental state, although it does not exclude it. As such it can be associated with multiple interpretations: a *cause*, *instrument* or an *agent*. The default interpretation for the feature cluster [+c] is *cause*. The lack of mental awareness of the event, but with a causal role [+c -m] is typically associated with an *instrument* (although it does not disqualify a *cause* interpretation, but the lack of mental state means it cannot be an *agent*). The *agent*, *instrument* and *cause* interpretations can therefore be identified by the /+c feature. In contrast the /-c value is associated with participants that are affected by the event; they have no causal role to play. This is typical of the traditional label *theme*: the argument that appears as the direct object in a transitive sentence. Reinhart (2002) regards the mental state of this affected argument traditionally interpreted to be the *theme* as irrelevant. "A [...] *patient* [an animate *theme*] of an event (say someone who got ridiculed) may have all kinds of mental states associated with that event. But we are talking about linguistic features, and the linguistic coding does not consider these mental-states relevant for the

argument structure.” (Reinhart, 2002: 254). Therefore a *theme* has a value $-m$. The $-m$ feature does not impose or exclude the animacy of the participant (Marelj, 2002). This means that what has been treated as a *theme* theta role is in fact the feature specification $[-c -m]$. The full list of theta clusters with their traditional role pairings is given in (29).

(29) *List of theta clusters*

$[+c+m]$ agent

$[+c-m]$ instrument

$[-c+m]$ experiencer

$[-c-m]$ theme

$[+c]$ cause

$[-c]$ recipient/goal/benefactor

$[-m]$ subject matter/source

$[+m]$ sentient¹⁰

(Reinhart, 2002)

We can see that the Theta System has only eight possible feature clusters: four fully specified: $[+c +m]$, $[+c -m]$, $[-c -m]$, $[-c +m]$, and four underspecified: $[+c]$, $[-c]$, $[+m]$, and $[-m]$. A fully specified cluster means that the causal and mental state of the participant assigned this relation is made explicit. Although fully specified clusters can be paired with traditional theta labels they can also be associated with other theta role labels modulo context. This is the case for *themes* and *patients* (a *theme* that has undergone a change of state). In (30) both objects must share the $[-c -m]$ cluster. There is nothing about the feature clusters that determines possession or the absence of it. This means that the verb meaning must determine whether this participant has undergone a change of state. In both sentences *the vase* is the affected participant of the event, but only in (30a) can its state be said to have changed.

¹⁰ See Pesetsky (1995) for arguments for the existence of this role.

- (30) a. Mary painted the vase/John_{PATIENT}
- b. Mary hit the vase/John_{THEME}

Importantly, this interpretive distinction between a *patient* and a *theme* (30a) and (30b) is not dependent on whether the participant is animate. This follows from the stipulation that the value /-m neither includes nor excludes an entailment of animacy. Therefore clusters [/-m] can be linked to sentient and non-sentient interpretations, but these are not relevant to the event (Reinhart 2002). Recall that this is in contrast to the cluster [+c] where mental state is underspecified. For this cluster any argument compatible with clusters with [+c/] features can be linked, and these may have relevance to the event. The event denoted by the verb and the context restrict the form of the compatible argument. This is an important distinction as we move the discussion onto the theta cluster associated with *goal* and *recipient* interpretations.

2.6.1. Goal/recipients and goal/locations

As seen in (29), the underspecified cluster [-c] corresponds to the traditional *goal* role. If an argument cannot be interpreted as being in a cause relation to the event, it must be specified as /-c (Everaert, Marelj, and Siloni, 2012). The mental state of this participant may be relevant to the event and this is why this participant is not specified with a value of /m. By underspecifying the mental involvement of the participant, these arguments are allowed to refer to participants who are both sentient and non-sentient to the event. The underspecified value is dependent upon other properties of the construction, such as the semantics of the verb and the context (Rákosi, 2006) just as we find with [+c]. The [-c] cluster can in theory be linked to any argument compatible to a [/-c] cluster, but for the syntax the relevant property is /-c. This means that the set of feature clusters relevant for both the dative construction *recipient* role in (31a) and the locative construction *locative* role in (31b) is the same. Non-thematic factors (such as contextual features) determines whether [-c] is interpreted as a *goal/recipient* and the latter a *goal/location*. The underspecification of the cluster allows the flexibility of pairing different kinds of *goal* participant.

- (31) a. John sent the letter to Mary.
 a'. John sent the boy to India.
 SEND ([+c +m], [-c -m], [-c])
 b. John loaded the boxes on the truck.
 b'. John loaded the boxes on Mary.
 LOAD ([+c +m], [-c -m], [-c])¹¹

This is important later for the syntactic analysis of the spray/load alternation. The feature clusters in (31) that are visible to the syntax are identical. Therefore the distribution of the arguments in a syntactic structure is expected to be identical for the locative construction and the dative construction. I now turn attention to the labels *possessor* and *recipient*.

2.6.2. Conflating Possessors and Recipients

A discussion about *possessor* and *recipient* theta roles is relevant to our discussion of the dative alternation. The distinction between these roles goes back to at least (Green, 1974) due to the perceived contrast between sentences like (32).

- (32) a. The editor sent the article to Sue.
 b. The editor sent the article to Philadelphia.
 c. The editor sent Sue the article.
 d. ??The editor sent Philadelphia the article.

(Harley, 2002: 35. Her 7.)

¹¹ We will see later that the [+c-m] cluster is not part of the feature specification for the spray/load alternation. However to avoid complication, I leave discussion until late in chapter 2.

The only interpretation available for (32d) is where *Philadelphia* stands for an organisation or a group of people rather than the city's physical location. This is widely attributed to a semantic requirement on the double-object construction but not the dative construction (e.g. Harley, 2002). In the double-object construction "the referent of the first [...] object must be the prospective possessor of the referent of the second object" (Gropen et al, 1989:207). This is claimed to be "because alienable possessors must be animate, [and] only animate referents may occur in the first [object] position in the double-object construction" (Harley, 2002:35). However, animacy is not a feature of the Theta System. Recall the /+m value is not animacy, it only entails animacy. Entailments belong to the Inference System not the syntax. It is possible to have a non-animate participant in the first object position as shown in (33).

- (33) a. John sent the data to the computer
 a'. John sent the message to Mary's phone
 b. John sent the computer the data
 b'. John sent Mary's phone the message.

In this system *the computer* and *Mary's phone* are both linked to the feature cluster [-c] which means they can take the form of any cluster with a [-c] compatible argument modulo context. This participant can then be either interpreted as a *recipient* or a *goal* depending upon the semantics of the event and the context. If the first object of a double-object construction has only a distinct possessor interpretation, then this argument must be paired with a [-c +m] cluster in order to maintain a consistent interpretation of possession. However, as we see in (33), *the computer* and *Mary's phone* are not /+m compatible arguments, yet they can both appear as the first object of a double-object construction. This means that all these arguments must both be linked to the [-c] cluster. An alternative is that all these arguments are linked to the cluster [-c -m]. Recall that this feature cluster has a *theme* inference. There are two problems with assigning this participant the [-c -m] cluster. The first I shall address here and the second is the topic of the following section. Firstly, the /-m feature means that the mental state of the participant is irrelevant to the event. An animate entity can therefore occupy the first position of the double-object construction. We should then expect to see a similar lack of restriction for inanimate arguments. However the kind of argument that can appear in

this slot is still highly restricted as I show in (34). This restriction cannot be attributed directly to animacy (Rappaport Hovav and Levin, 2005). An inanimate argument such as *computer* or *telephone* can occupy this slot, although other types of inanimate referents such as *desk* cannot. This then becomes a problem for what it means to have a mental state.¹²

- (34) a. John sent the data to Mary/the computer/the telephone/Philadelphia/?the desk.
b. John sent Mary/the computer/the telephone/?Philadelphia/*the desk the data.

For this reason, the goal cannot be associated with a /-m feature. Alternatively, we can place the burden on the context of the event. Notice that the *goal* is sensitive to the type of *theme*.

- (35) a. John sent Mary/ the computer the data.
b. John sent Mary/*the computer the letter.
c. John sent ?Mary/the computer the virus .

If the compatibility of arguments has more to do with context, then we can retain the [-c] cluster for the inferred *goal* participant of *send*. Different kinds of referents are available depending on the context. The core meaning of the sending event is maintained.¹³ Therefore the restriction cannot simply be attributed to the presence of a *possessor* thematic label. Importantly, what it does mean is that both (34a) and (34b) have the same thematic grid: ([+c +m], [-c -m], [-c]). This is important as it

¹² If it turns out the /m feature is important to the kind of event denoted by verbs like *send*, then the problem is about what it is to have a /+m mental state in this system. What then is the property of positive mental states which are embodied in referents like *telephone* or *Mary*, and how can these be related to other [/+m] clusters such as *experiencers*?

¹³ This does not exclude the well known effect that animacy has on word order (e.g. Bock et al., 1992; Bresnan and Hay, 2007; Branigan et al, 2008) but excludes it from being an active feature in theta clusters.

means that a verb like *send* needs only one lexical entry with one thematic grid. I return to this point in section (2.14). The second problem with pairing a [-c -m] cluster with a *goal* participant has to do with the rules that govern the co-occurrence of theta clusters – the Identity Constraint and the Cluster Distinctness constraint. This is the topic of the next section.

2.7. Rules that govern the co-occurrence of theta clusters

There are two rules that are assumed to govern the co-occurrence of theta clusters in the Theta System: The Identity Constraint and the Cluster Distinctness constraint. The Identity Constraint is a core rule in most thematic frameworks. Recall that every theta role must be distinct (e.g. Bresnan, 1982a; Parsons, 1990; Carlson, 1998). The system of concepts does not generate verbal concepts of events with two identical theta roles (Marelj, 2002). The participants in an event are related to that event by distinct thematic relations. The constraint is stated in (36).

(36) *The Identity Constraint*

Two identical theta roles cannot be realised on the same grid.

In order for this restriction to be applicable to feature clusters, an additional theory internal rule is assumed. This is the Cluster Distinctness constraint. It restricts the kind of theta clusters that can appear together. It is stated in (37).

(37) *Cluster distinctness*

- a. Two indistinct θ -clusters cannot be both realized on the same predicate.
- b. Distinctness: Two feature-clusters α , β , are distinct iff a. they share at least one feature, and b. there is at least one feature or value which they do not share.

(Reinhart, 2002: 271. Her 59.)

Immediately we see that (37a) excludes the interpreted *goal* in (34) from having a [-c-m] cluster. The *goal* participant cannot have the same feature cluster as the *theme*. However, it does not prevent the occurrence of the underspecified [-c] cluster. The /-c feature is shared by the interpreted *theme* and *goal*. This provides the basis for a comparison of distinctness by (37b). They are distinct because the former has the value /-m and in the latter it is underspecified. The lexical entry has distinct feature clusters on its thematic grid. An inference that the argument paired with the underspecified cluster is non-sentient is not excluded if warranted by the context (although see Marelj, 2002 for a different analysis based on the full binary specification of unary clusters prior to interpretive processes).

I have provided an overview of the variables of Reinhart's (2000; 2002) Theta system. I showed that on this view, a theta role is an inference based on the coding of two binary features: /m and /c. These features are realised as either /+ or /- or are left underspecified. I showed that certain feature clusters are consistently associated with particular theta labels such as the [-c-m] cluster being linked to a *theme* interpretation. I also showed that the underspecified cluster [-c] can be associated with *goal* type arguments. I argued that based on the available information in the theta cluster the [-c] cluster cannot distinguish a *goal/recipient* from a *goal/location*. I also argued that the [-c] cluster is linked to an argument that can be interpreted as a *possessor*. This means that the possessor relation is not specified in the thematic grid as it cannot distinguish a *goal/recipient* from a *recipient/possessor*. I proposed that the context helps to shape the interpretation of this underspecified cluster as a *location*, a *goal*, or a *possessor*. I will now move the discussion to the syntactic effects of feature clusters. In this system, the mapping to syntax is captured on the basis of the values of feature clusters.

2.8. The mapping of theta relations to syntax

The Theta System adopts the notation of Williams (1981), where instructions for linking theta roles into the syntactic structure are contained in the lexicon, and distinguished with indices. The index 1 marks a subject role, and the index 2 marks an internal role. This marking is not part of individual verb entries, but determined by the composition of feature clusters available in the theta system. These marking rules are given in (38), and linking the merging instructions are given in (39).

(38) Lexicon Marking

Given a n -place verb entry, $n > 1$

- a. Mark a [-] cluster with index 2
- b. Mark a [+] cluster with index 1
- c. V with a [+] cluster and a fully specified [/c] cluster is marked for ACC.

(39) Merging Instructions

- a. When nothing rules this out, merge externally¹⁴
- b. An argument realising a cluster marked 2 merges internally; an argument marked 1 merges externally.

(Reinhart, 2002: 255. Her 27 and 29 respectively.)

Feature clusters belong to the three distinct classes given in (40).

- (40)
- a. [-] clusters: [-c -m], [-c], and [-m]
 - b. [+] clusters: [+c +m], [+c], and [+m]
 - c. 'mixed clusters': [-c +m], [+c -m]

A mapping summary is given in (41).

¹⁴ In other words to the sentence subject position.

(41)

	Type of cluster	Clusters	Marking	Mapping
a.	[-]	[-c -m] (<i>Theme</i>)	2	Internal
		[-c] (<i>Goal</i>)		
		[-m] (<i>Subject Matter</i>)		
b.	[+]	[+c +m] (<i>Agent</i>)	1	External (subject)
		[+c] (<i>Cause</i>)		
		[+m] (<i>Sentient</i>)		
c.	mixed	[-c +m] (<i>Experiencer</i>)	None	If a [+] cluster is present internal, otherwise external (subject)
		[+c -m] (<i>Instrument</i>)		

(Everaert, Marelj, and Siloni, 2012: 11. Their 11.)

The [+] clusters are marked with the index 1 because of (38b), and as such are merged to the subject position due to (39b). As only one argument may be mapped to the subject position, (39a) prevents a lexical entry from specifying multiple [+] clusters in their thematic grid. There is no such restriction on the marking of [-] clusters. The theta system has no restriction on the order of merge or any limitation on the number of [-] clusters in a thematic grid. They are all marked with the index 2 and are subsequently merged internally however many there are; that is unless (39a) applies. In principle, nothing prevents a [-c] cluster from being the first to merge with the verb. However, the licensing of accusative case is considered to be a restricting factor (Marelj, 2005; Preminger, 2006). Recall that in (38c), the argument paired with the fully specified [-c -m] cluster is assigned Accusative case in a transitive sentence. We will see in (2.12) that Accusative case is licensed in a structure where the verb is left-adjacent to the accusative marked argument. This will determine its possible position in the structure.

The mixed clusters of the Theta System are not assigned an index. This means these clusters are free to merge either to the subject position or internally. As there is only ever one argument in subject position per verb, mixed clusters are blocked from merging to subject position when one of the [+] clusters in (41b) is present. This means that when the [+c -m] cluster (usually attributed to an *instrument* interpretation) is in a thematic grid, it is predicted to be the argument in subject position when there is no [+c] or [+c +m] cluster in that grid. In (42a) there is a [+c +m] in the thematic grid,

and so this argument merges to subject position. The [+c –m] must then merge internally as can be seen with the contrast in (42a'). In (42b) there is no [+c] cluster and so the [+c –m] merges to the subject position.

- (42) a. The knight stabbed the knave with a sword.
 a'. (*with)*a sword stabbed the knight a knave.
 STAB ([+c +m], [–c –m], [+c –m])
 b. A sword stabbed the knave
 STAB ([+c –m] [–c –m])

This is important as some researchers have attributed an *instrument* interpretation to the *with*-PP in the *with*-variant construction of the spray/load alternation such as *the boxes* in (43). I will leave discussion of this until section (2.16.3).

- (43) John loaded the truck with the boxes.
 LOAD ([+c +m], [–c –m], [+c –m])

The Theta system efficiently captures generalisations about the distribution of arguments. For example, recall that the verb *open* in (33) (repeated below in (44) but with feature clusters rather than thematic labels) can have an *agent*, *cause*, or *instrument* type argument in subject position.

- (44) a. John [+c+m] opened the window [–c –m].
 a'. *The window [–c –m] opened John [+c+m].
 b. The key [+c] opened the window [–c –m].

- b'. *The window [-c -m] opened the key [+c].
- c. The wind [+c] opened the window [-c -m].
- c'. *The window [-c -m] opened the wind [+c].
- d. The window [-c -m] opened.

In accounts that identify these theta roles as distinct semantic labels (e.g. Pinker, 1989), then a verb such as *open* must be listed as three lexical entries; each selecting a different role that is linked to the subject position. In Reinhart's system, *open* is listed only once with a single thematic grid as in (43). The merging instructions guarantee that the [+c] argument will end up as the argument in subject position. The underspecification of /m means that an *agent*, *cause*, and *instrument* interpretations are available. The context will determine what kind of interpretation this cluster will get. It also means that [-c -m] receives accusative case as in (38c). It also means that the unaccusative sentence in (44d) is licensed by (39a), as there is no argument blocking the merger to subject position.

(45) OPEN ([+c], [-c -m])

The status of the underspecified cluster [+c] allows multiple interpretations, and this is dependent on verb meaning and context. I have argued that this is also the case for the [-c] cluster. I showed that a *locative*, a *recipient* and a *possessor* interpretation must stem from the same [-c] cluster as the kind of argument that can be paired is dependent upon the context. I showed that this cluster has a default mapping to an internal argument. This suggests that there are generalities that still can be caught in a hierarchy; that is, a more simple thematic hierarchy based on the value of theta clusters. This is a new idea and is the topic of the next section. There I show that that the [-c -m] cluster is one of the lowest clusters on the hierarchy. This is based on the explicit realisation of values on features of a cluster.

2.9. A feature cluster hierarchy

Recall from (2.5) that the Thematic Hierarchy is problematic. There is wide disagreement with the types of theta role that have been proposed and also their relative ordering in the hierarchy. The analyses tend to focus on distinguishing theta role labels rather than capturing generalities shared by various role interpretations. This focus has been on discovering fine-grained differences between labels. One reason for that approach is to account for differences of argument order found in double-complement structures such as those found in the dative alternation. However, in the Theta System the difference between a *possessor* and a *recipient* interpretation is not relevant to the syntax, nor is the difference between a *recipient* and a *locative*. What is relevant is that they all share the same [-c] feature cluster. Conflating these theta role labels and analysing them in terms of their cluster specification has the consequence that proposals about their relative structural ordering are made moot. The set of theta interpretations linked to the [-c] cluster occur higher on the hierarchy than *themes*. I will now show that this is a relation that exists between feature values which orders the clusters in to a hierarchy. The focus of proposing a hierarchy is to provide a basis to argue that the ranking of features on the hierarchy results in an ordering of [-c] and [-c-m] where [-c] consistently appears higher on the hierarchy than [-c-m]. This structural relation between [-c] and [-c-m] is uniform. In what follows, I show the overall structural relation between cluster groups [+], [-], and the mixed clusters. I do not provide a complete hierarchy of all possible feature clusters; the relation between the underspecified members of [-], between the underspecified members of [+], and between the members of the mixed cluster group is not given. However, I do show the relation between the underspecified cluster [-] clusters and [-c-m].

2.9.1. The ordering of values

Recall that it is uncontroversial to place *agent* at the top of the thematic hierarchy. This is a consistent interpretation of the feature cluster [+c +m]. When an agent is present it always maps to the subject position. This supersedes the merging in subject position of any other cluster with a /- value; either the mixed cluster [-c +m] or [+c -m], or a [-] cluster. When an underspecified [+] cluster is present, this cluster also takes precedence over a cluster with a /- value, as I show in (46).

- (46) a. The wind opened the door.
 OPEN ([+c], [-c -m])
- a'. The door opened.
- b. The world worried Max.
 WORRY ([+c], [-c +m])
- b'. Max worried.
 WORRY ([-c +m])
- c. Max loved the game.
 LOVE ([+m], [-m])

This suggests that a cluster with a /- value will always be structurally inferior to a cluster without a /- value. Further evidence for the inferiority of a [-] can be seen in cases where there are two clusters with a /- feature and one of those clusters also has a [+] value (a mixed cluster) then this mixed cluster will be the one that merges to the subject position as I show in (47) and (48).

- (47) a. John cut the bread with a knife.
 CUT ([+c +m], [-c -m], [+c-m])
- b. *The bread cut the knife.
 *<[-c -m], [+c-m]>
- b'. The knife cut the bread.
 <[+c-m], [-c -m]>

- (48) a. Peter felt the breeze
 <[-c +m], [-c -m]>
- b. *the breeze felt Peter
 * <[-c -m], [-c +m]>

Based on these data, I propose that a uniform structural hierarchy exists; at the very least between cluster groups. I propose that cluster groups are ordered as in (49). Clusters higher on the hierarchy appear more to the left.

(49) **Cluster Group Hierarchy.**

[+] clusters, mixed clusters, [-] clusters.

The next task is to try and order the members of the cluster sets. However, to do this exhaustively at this point will take us too far from the task at hand; however, the granulated structure of the hierarchy will be addressed in this thesis. As the chief concern is the relation between the [-c -m] and [-c] clusters, I will focus on the expansion of the [-] cluster group.

As we have seen, the /+ value means that a cluster with this value appears structurally higher than a cluster that does not have this value, either because the cluster realises a /- value or it is underspecified. It is then assumed that this premise holds whether the value is realised for both features on a fully specified feature cluster ([+c +m]) or on only one feature of an underspecified [+] cluster ([+c], [+m]). It is the realisation of a value that seems to be significant in the Theta System. Recall that a cluster underspecified for /c can either be [+m] or [-m]. The [+m] cluster always maps to the subject position, the [-m] cluster can only map to the subject position if nothing blocks it from doing so. When an additional value is present its probability of mapping to the subject position is altered. Firstly, if [+m] is expanded to the fully specified cluster [-c+m], the presence of the /- value means that the argument is not obligatorily mapped to the subject position. [+m] can have an [-c+m] interpretation (a *sentient* as an *experiencer*) but it is the presence of a /- value that has an effect on mapping. A specified /- value has an effect whereas an inferred /- value does not. If the presence of

a /- value is important to lower positions on a hierarchy, then it is predicted that a /+ value should have a raising effect. Recall that an underspecified [+] cluster cannot exist on the same thematic grid, then in order observe an effect, we must turn attention to underspecified [-] clusters ([-c], [-m]). These clusters (and the mixed clusters) can map internally, and in principle there is no restriction on the number of internal arguments. When the two clusters [-c-m] and [-c] are in a thematic grid such as in an event denoted by a dative verb, then it is expected that the presence of an additionally valued (/ -m) variable is the significant factor. The additional specified /- value should force this argument to map lower in the structure than the underspecified value. In order to illustrate this I will show this structural ordering by examining the distribution of the underspecified [-m] cluster.

The [-m] cluster is associated with *subject matter/target of emotion* (Pesetsky, 1995) interpretations (cf. example 29 above). They are found with experiencing verbs like worry in (50a). They occur in sentences where the experiencer appears in subject position; labelled as ‘subject experiencer’ sentences in Pesetsky (1995:19). The argument paired with the [-m] cluster in (50a) is interpreted as the subject matter; it is not inferred as being causal (see Pesetsky, 1995: ch 3). This is in contrast to (50b) in which *something* is a *cause* ([+c])¹⁵ (Pesetsky, 1995; Reinhart, 2002, Hartmann, 2008). The [-m] cluster cannot appear as the subject over the [-c +m] as I show in (50c).

(50) a. Lucie worries about something.

WORRY ([-c +m] [-m])

b. Something worries Lucie.

WORRY ([+c] [-c +m])

(Reinhart, 2002:258. Her 40.)

c. *About something worries Lucie.

¹⁵ Pesetsky (1995) argues that both (50a) and (50b) realises the thematic grid. Their grid contains all three thematic roles but a restriction exists that prevents a *cause* and a *source* from being realised overtly on the same predicate; although see Hartmann (2008) who argues that there are examples where the three roles do occur on the same predicate.

A [-c +m] *experiencer* can also appear internally with a [-c] cluster (51a)¹⁶. In the absence of the [+c] cluster, only the [-c +m] cluster can appear as the argument in subject position, as I show in (51).

- (51) a. Something worried Max at the park.
 b. Max worried (about something) at the park.
 <[-c +m], [-c]>
 c. *At the park worried Max (about something).
 *<[-c], [-c +m]>

The data in (50) and (51) suggest that it is the specifying of the /+ feature that is significant. A cluster without a /+ value is structurally inferior to a cluster where this value is specified. If this effect occurs with the specification/underspecification of /+, then a similar effect is predicted with the specification/underspecification of /-.

- (52) The financial crash affected banking practices.

In (52) the financial crash is not a direct cause of the change in banking practices and so cannot be listed with a /+c value. It must be listed with a value of /m otherwise the participant cannot be identified in the event¹⁷ as it would be an empty cluster as no feature is specified. The options available are either /+m or /-m. The former means that the argument must be marked for a positive mental

¹⁶ Here *at the park* is the location of Max when he experienced the worry, not the location of the source of the worry. Compare, *Max worried (about something at the park)*.

¹⁷ Marelj (2004), and Ackema and Marelj (2012) argue for the existence of an empty cluster. However, they argue that this cluster is limited to the thematic grids of light verbs such as *have*, and middle constructions.

state. As can be seen in (53), there is not a condition on the argument/cluster pairing. This means that the only option is /-m, as the mental state is not a determining factor.

(53) The baby affected John's mood.

The *banking practices* meets the semantic criteria for a *theme*. The action explicitly identifies *the banking practices* as the affected argument. In terms of its cluster, this argument is not causal to the event and so must be linked to the value /-c. This cluster also has the feature /m. If this feature was also marked with the /+ value, it would have to map to the subject position according to mapping rules. The /m feature must therefore be marked for /-¹⁸. This means it is a [-c -m] cluster which matches up with the semantics. Recall that the [-c -m] is typically interpreted as a *theme*.

What this analysis has shown is that /+ values are superior to underspecified values, and underspecified values are superior to /- values. This means that according to these data, feature clusters can be ordered into a uniform hierarchy. The hierarchical relation between /c and /m features is an outstanding problem, and is addressed in due course. The form the hierarchy takes at this stage is shown in (54)¹⁹. Clusters separated by / indicate that proposals about their hierarchical interrelation are unresolved.

(54) *The Feature Cluster Hierarchy*

[+c +m], [+c]/[+m], [+c -m]/[-c +m], [-c]/[-m], [-c -m]

In this section I have proposed a structural hierarchy of theta clusters. I have shown that clusters with /+ values appear higher on the hierarchy than a cluster underspecified for that value. I have also shown that clusters with /- values appear lower on the hierarchy than a cluster underspecified for that value. Importantly, I showed that [-c] must occur higher in a structure than [-c -m]. This is

¹⁸ There is the possibility that this feature is underspecified. However, a verb like affect cannot have an object with a goal interpretation.

(i) *The financial crash affected to the bank/to the business man.

¹⁹ The position of [-m] will be adjusted as we proceed.

significant as it provides support for the syntactic analysis of double-complements used in this thesis. It is to this topic that I now turn.

2.10 The syntax of double-complements.

The intention of this thesis is to provide a comprehensive account of the spray/load alternation. Most contemporary analyses of the spray/load alternation predominantly follow a semantic approach (e.g. Pinker, 1989; Boas, 2003a; Goldberg, 1995; Iwata, 2008). This is to say that the constructions in an alternation are identified by their specific independent meanings. Each variant in an alternation has a distinct meaning which describes a different event. But before any consideration of the factors that may trigger a preference for one of the constructions in the alternation, one must address how the structures for these constructions are represented in the syntax. This will be relevant to later discussion about what licenses and constrains certain structures over others. As noted in the introduction, the structures involved in the spray/load alternation have received relatively little attention compared to the structures of the dative alternation. The reported semantic difference between the variants in the spray/load alternation suggests that the alternation cannot be syntactically derived; under the assumption that the syntax cannot extend the basic meaning of a predicate (Baker, 1997). It is therefore difficult to reconcile a transformational analysis with a view that each construction is semantically distinct as two distinct meanings cannot arise from a single subcategorisation of a verb. This has meant that most mainstream analyses of double-complement structures have not adequately considered the structure of the spray/load alternation. As we will see later, the motivation for a transformational structure has been attributed to Case considerations. If case is the motivation for a transformational process, and the semantics cannot extend a basic predicate meaning, then what is left unanswered is the reason why in one instance, a structure is projected that does not require any further transformation, and in another instance, exactly the same structure is projected, yet it is in some way deficient to the former as an additional transformational process is required to make the sentence well-formed. An alternative method is a non-derivational analysis of an alternation – a base-generated approach – where each construction is independently formed, and a predicate's arguments are generated in the position in which they appear. When one of the variants is not transformed from the other, then correspondences between syntax-external triggers on an alternation are more easily mapped to differences in structure. In this thesis, I propose that the structures of the constructions of the spray/load alternation parallel those in the dative alternation. In order to capture the effect of contextual factors on the word order of objects in the spray/load alternation, an account of the English VP which proposes the base-generation of

arguments will be adopted and used to compare the structures of the spray/load alternation with the structures of the dative alternation. An account of the VP that derives one alternation from the other restricts the two resulting structures from being independent. The account of the VP adopted in this thesis is proposed by Janke and Neeleman (2012), which argues for the presence of two distinct syntactic constructions for double-complement structures in English. One structure is based on Chomsky (1981), the other construction is based on Larson (1988). This chapter will review both of these classical approaches before reviewing Janke and Neeleman (2012).

2.11. The structures of double-complement structures

Many diverging theoretical accounts of the structure of double-complements have been put forward over the last thirty years (see especially Oehrle, 1976; Chomsky and Lasnik, 1977; Larson, 1988a; Aoun and Li, 1989; Johnson, 1991; Hale and Keyser, 1993; Pesetsky, 1995; Baker, 1988, 1997; Neeleman and Weerman, 1999). These proposals have attempted to account for a number of phenomena that seem sensitive to syntactic structure. In a dative alternation, these phenomena occur in asymmetric distribution across the dative construction and the double-object construction. This in turn led to contradictory indications of their underlying structure(s). Janke and Neeleman (2012) have provided one proposal, by arguing that English double-complement structures can be built via one of two syntactic structures, which, it is argued, can account for the problematic data. This base-generated account provides the syntactic frame of this thesis. I review two of the major accounts of the structure of double-complement structures: a Chomskyan ascending structure (Chomsky, 1981) in (2.11.1), and a Larsonian descending structure (Larson, 1988) in (2.11.2) Data that is problematic will be discussed for each of these theories, and then a review of Janke and Neeleman (2012), in which it is claimed that a double-complement construction can have either an ascending or a descending structure, will be given in section (2.12) I will now begin with a uniformly ascending structure.

2.11.1. A uniformly ascending tree structure and its problems

Early proposals of the structure of double-complement structures argued for an ascending tree structure as in (55) from Chomsky (1981). This structure is ascending because the constituents that are attached further to the right are attached higher²⁰.

(55)

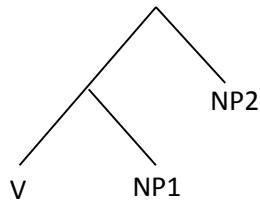

The structure in (55) was proposed as the uniform structure for both of the variants in an alternation as can be seen in (56).

(56) a.

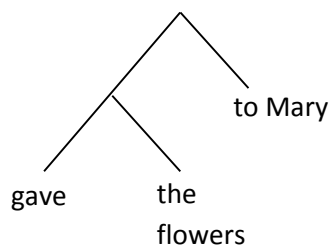

b.

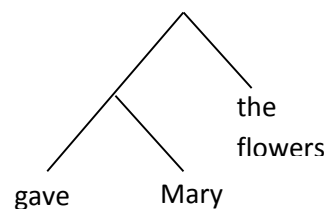

However, Barss and Lasnik's (1986) influential squib showed that syntactic conditions such as those involved with the binding of anaphors do not fit well into the ascending structure in (55), because the structure is at odds with what was then assumed to be the conditions on binding. Specifically, the ascending parse can generate a tree in which anaphors are not c-commanded by their antecedents

²⁰ In this section only, I adopt the labelling of arguments in Chomsky (1981). The order of the arguments is rigidly V NP1 NP2, irrespective of the type of argument it is. I revert back to the distinction that I specified in chapter 1 at the end of this section.

yet are still well-formed. Chomsky (1981, 1986) argued that every anaphor must be coindexed with an antecedent in an appropriately defined command relation within an appropriately defined minimal syntactic domain. The condition that governed the coindexation of a reflexive and its antecedent was captured by Condition A of Binding Theory. Condition A states that a reflexive anaphor must have a local (and structurally higher) antecedent (Chomsky, 1981). In this way the antecedent is structurally superior as it is attached higher than its anaphor. The idea of structural superiority is conditioned by the notion of c-command. A common definition of c-command is (57) from Reinhart (1976)²¹.

(57) X c-commands Y iff the first branching node dominating X dominates Y.

This essentially means that a node (N_2) c-commands another node (N_1) if (N_2) is structurally higher than (N_1) (N_2 dominates N_1), and that a path can be traced downward from the branching node that connects N_2 with the material that minimally contains N_1 (N_1 is in the c-command domain of N_2).

The tree in (55) demonstrates that in an ascending tree, NP2 dominates NP1, and NP1 is also within the c-command domain of NP2. However the ascending structure in (55), together with the restrictions on binding given in (57), is at odds with the pattern of grammatical judgements for the reflexives in (58) below.

(58) a) I showed John_i (NP₁) to himself_i (NP₂) (in the mirror).

a') *I showed himself_i (NP₁) to John_i (NP₂) (in the mirror).

(dative construction)

b) I showed John_i (NP₁) himself_i (NP₂) (in the mirror).

b') *I showed himself_i (NP₁) John_i (NP₂) (in the mirror).

(double-object construction)

(Barss and Lasnik, 1986: 347. Their 2 and 3.)

²¹ Many definitions of c-command exist in the literature. We use Reinhart (1976) simply because this was the definition of c-command used in Larson (1988) who posited a descending structure to the double-object construction as a reaction to Barss and Lasnik (1986); the topic of section (2.11.2).

The structure in (55) predicts (58a') and (58b') to be grammatical. The antecedent *John* is the most local antecedent to the reflexive *himself* and is also structurally higher, and so the conditions on the binding of a reflexive are met as can be seen in (59). (Only the tensed verb and its complements are shown).

(59) a.

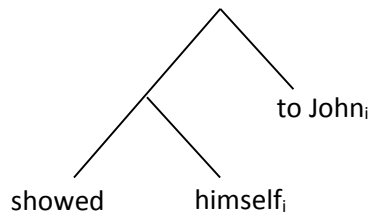

(dative construction)

b.

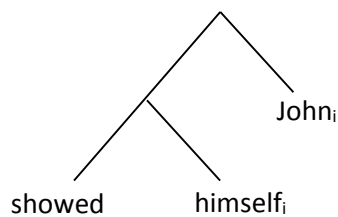

(double-object construction)

However, the reflexive and the antecedent do not co-refer and the sentence is unacceptable (as *himself* cannot be bound by the 1st person subject). (55) also predicts (58a) and (58b) to be ungrammatical. The anaphor *himself* is the NP₂, so it is structurally higher than its antecedent. Since the antecedent does not c-command its anaphor, this configuration should result in ungrammaticality, as evident in (60).

(60) a.

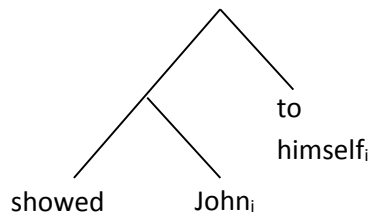

(dative construction)

b.

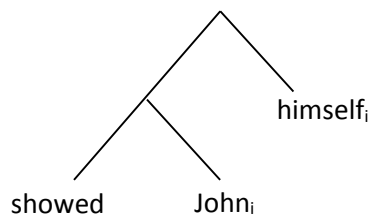

(double-object construction)

However the anaphor and its antecedent do co-refer and the sentences are acceptable. In the contemporary literature conditions on Binding have been substantially revised, however, the ‘condition A’ effects are still seen by many to be significant to contemporary Binding Theory (e.g. Buring, 2005).²²

Barss and Lasnik also observed that an ascending structure was inadequate to account for the relation between a quantificational noun-phrase (QNP) and a pronoun in a double-object construction as in (61). In order for a pronoun to be related to a QNP, the pronoun must be in the structural c-command domain of the QNP.

(61) a. I denied each worker_i his_i paycheck.

b. *I denied it_is owner each paycheck_i.

(Barss and Lasnik, 1986: 348. Their 6a and 7a.)

²² It has been argued that precedence is a determining factor for the binding of anaphors in Williams (1997), which invalidates this observation of anaphoric relations in Barss and Lasnik (1986). However, what is being determined at this stage is an historical development of the syntactic literature of double-complement structures rather than a particular critique of Barss and Lasnik. The argument in Williams (1997) will be addressed in due course.

The uniformly ascending structure in (55) predicts that (61a) should be ungrammatical as the arguments *his paycheck* is the NP2 and thus higher in the tree-structure, in which case it should c-command the co-indexed antecedent. Conversely the examples in (61b) should be grammatical as the antecedent *each paycheck* correctly c-commands its pronoun according to the definition in (57) and the ascending structure in (55), yet this example is ungrammatical²³.

The asymmetry between the dative construction and the double-object construction with respect to an ascending structure can be seen in other syntactic phenomena observed by Barss and Lasnik (1986), namely, wh-movement and weak crossover, Superiority, and the licensing of negative polarity items (NPIs).

In wh-movement and weak crossover, it is difficult to get a coreferential reading between a pronoun and a moved wh-phrase antecedent when the wh-phrase *crosses over* a noun phrase containing a possessive pronoun with which it is co-indexed. This is shown in (62) (*t* is the standard symbol for *trace* which represents the position from which an argument has moved).

- (62) a. Which worker_i did you deny *t* his_i paycheck?
 b. Who_i did you show *t* his_i reflection in the mirror?
 c. *Which paycheck_i did you deny it_i's owner *t*?
 d. *Which lion_i did you show it_i's trainer *t*?

(Barss and Lasnik, 1986: 348. Their 8 and 9.)

²³ Interestingly, as shown in Larson (1988), the structure in (55) does not fit well with the dative construction either, as in (i). This is further evidence to suggest that precedence is a determining factor.

- (i) a. I gave every check_i to its_i owner.
 b. ??I gave his_i paycheck to every worker_i

(Larson, 1988: 338. His 5b)

To get the coreferential meaning, the tail of the wh-phrase movement chain (t) must c-command the pronoun it is co-indexed with. In a uniformly ascending structure, (62a) and (62b) should then be ungrammatical as the *trace* is in NP₁ position, which means that it is structurally lower than the co-indexed pronoun in NP₂ as seen in (63) and (64) respectively. (In (63) and (64) an ‘*’ marks the ungrammaticality predicted by a uniform ascending structure only).

(63)*

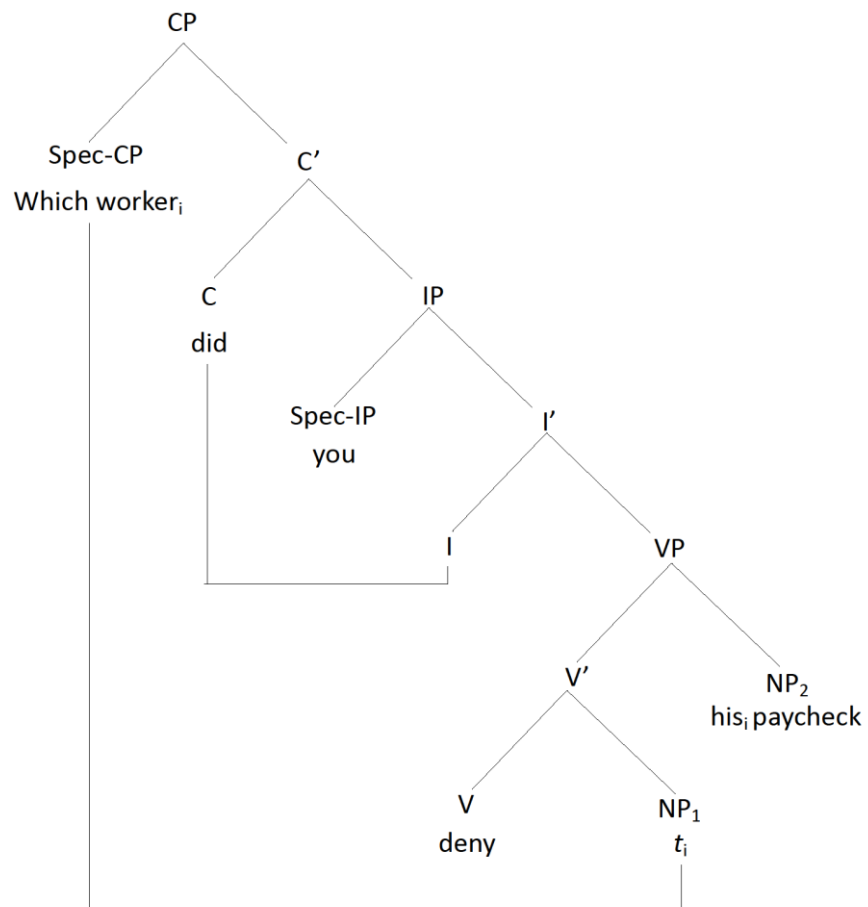

(64) *

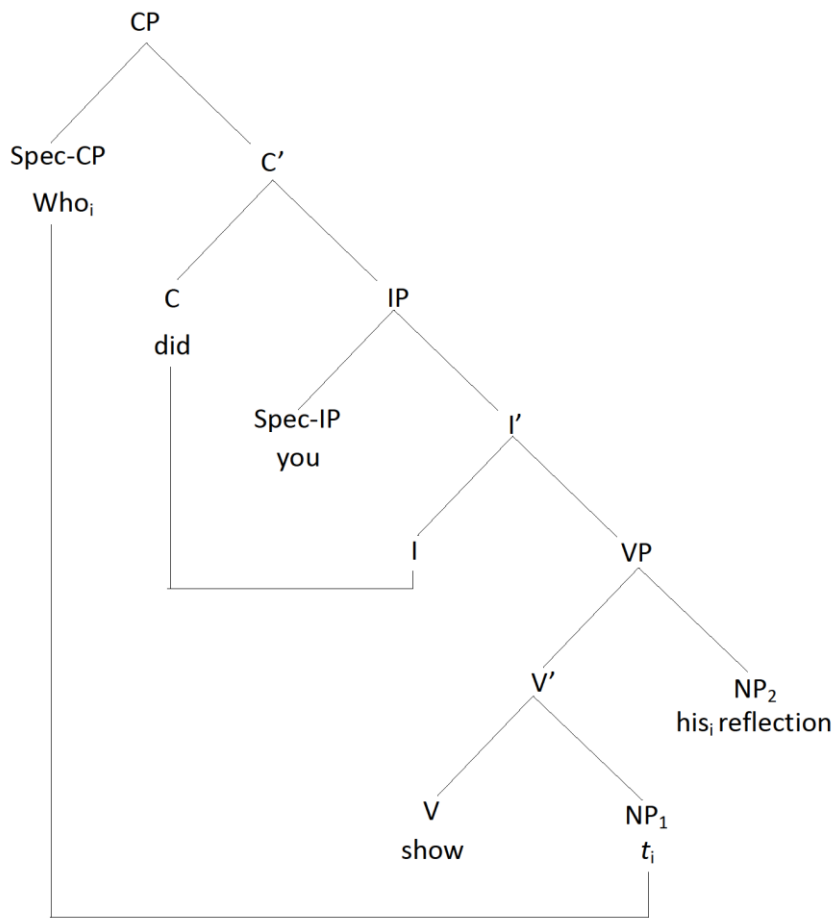

The reverse is predicted for (62c) and (62d), which should be grammatical, as the trace in NP₂ c-commands the NP₁ pronoun, as can be seen in (65) and (66) respectively. ((65) and (66) are not marked with an '*' to show the acceptability predicted by an ascending structure only.)

(65)

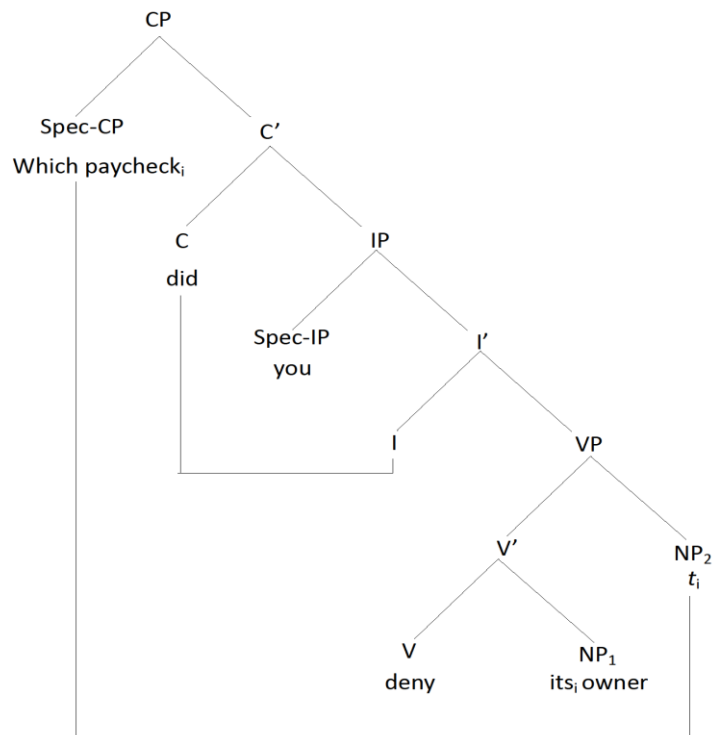

(66)

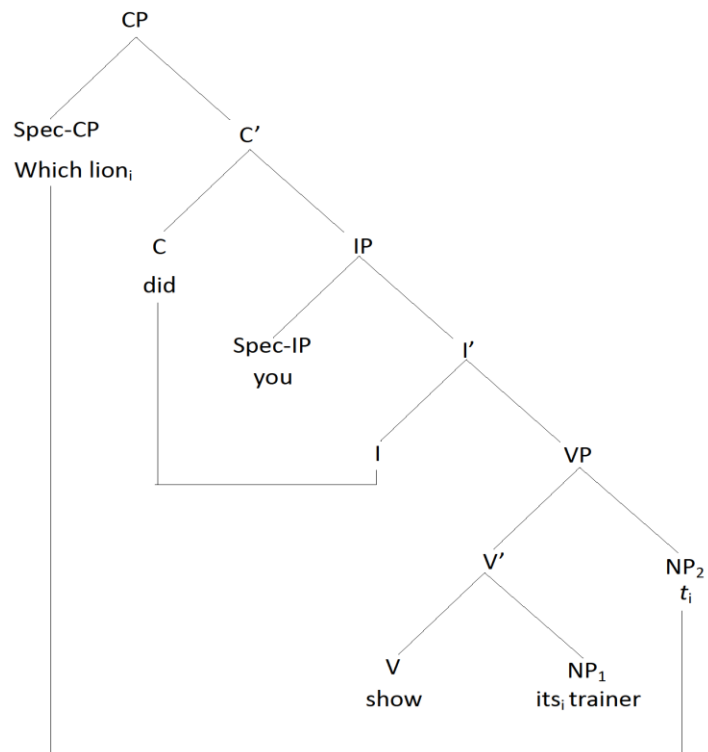

The same problem can be seen with trying to capture superiority effects. Superiority refers to a situation where a sentence has two *wh*-phrases, usually only the structurally higher one can move to the left of the clause (Chomsky, 1973)²⁴. This is illustrated in (67) and (68). In (68) the examples are only grammatical with an echoic reading.

- (67) a. Who did what?
b. Who went where?
c. What happened to whom?
d. What did you give to whom?

- (68) a. *What did who do?
b. *Where did who go?
c. *To whom did what happen?
d. *To whom did you give what?
d'. *Who did you give what to?

(Kuno and Robinson, 1972: 474. Their 3-1 and 3-2.)

According to this condition, the NP2 in an ascending structure should be able to move to the left but this is not the case as can be seen in (69) and (70), whether the construction is a dative construction

²⁴ There are exceptions to this effect. For example, instead of *who* and *what*, such phrases as *which person* and *which book* seem to weaken the effect, as in (i)

- (i) Which letter did you send to which person
(ii) To which person did you send which letter

There is a difference in this case between whether the variable that is being questioned is new or *Given*. *Who* implies that the speaker does not know the identity of this referent, whereas *which person* implies that the identity of the person may belong to a member of a known set of referents.

(69a) or a double-object construction (70a). However, the reverse happens as illustrated in (69b) and (70b). NP1 can move to the left of the sentence even though it is the lower of the two NPs.

(69) *You gave which book to whom?*

- a. *(To whom)_i did Bill send which letter t_i ?
- b. (Which book)_i did you give t_i to whom?

(70) *You gave who which book?*

- a. *(Which book)_i did you give who t_i ?
- b. Who_i did you give t_i which book?

(Barss and Lasnik, 1986: 349. Their 11.)

Lastly, the same problem surfaces with respect to polarity. A negative polarity item (NPI) (e.g. *any*) is only licensed in non-veridical contexts, one of which is negation. Structurally, the NPI must be in the c-command domain of the negation as seen in (71).

- (71) a. No one saw anything.
- b. *Anyone saw nothing.

Again if we apply these conditions to the constructions from the dative alternation, the negation must occur in a structure in which it is structurally higher than the NPI for the sentence to be grammatical (e.g. Hoeksema, 2000). The structure in (55) predicts that only when the negation is attached to the NP2 position can an NPI attached to the NP1 position be licensed, as the negation is structurally higher

in the tree than the NPI and so the NPI falls within its domain. The structure in (55) predicts (72a) and (72b) to be ungrammatical because the negation is structurally lower and thus cannot c-command the NPI. However these sentences are acceptable. Conversely, the ascending structure in (55) predicts (72a') and (72b') to be grammatical because the negation is structurally higher and c-commands the NPI. However these structures are not acceptable.

- (72) a. I gave nothing to anyone.
a'. *I gave anything to no one.
- b. I gave no one anything.
b'. *I gave anyone nothing.

(Barss and Lasnik, 1986: 350. Their 18 and 19.)

In light of the problems highlighted by Barss and Lasnik (1986), a new account was proposed in Larson (1988). This is presented in the next sub-section.

2.11.2. A uniformly descending tree structure

Because of the observations of Barss and Lasnik (1986), Larson (1988) proposed that the ascending structure in (55) was not the correct structure for either the dative or the double-object constructions as it did not capture the relation between c-command and word order. In order to capture this relation, Larson (1988) proposed that the VP of the dative construction had a structure like (73). (From now on I revert back to the NP labelling presented in chapter 1. NP1 corresponds to the traditional classification of direct object, and NP2 corresponds to the indirect object.)

(73)

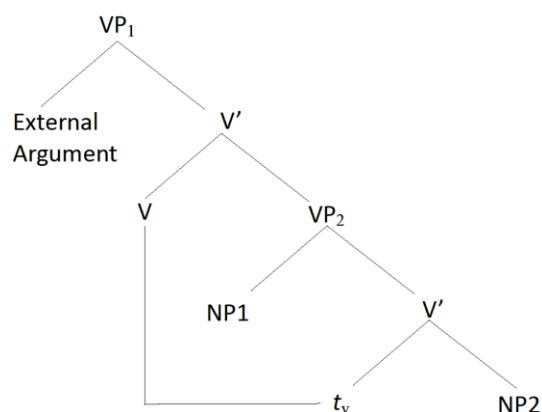

The claim is that there is not a single Verb Phrase (VP) but two VPs that make up the basic structure in double-complement structures, as can be seen in (73). This structure will be referred to as a descending structure because constituents to the right are attached lower. The descending structure consists of two VPs – VP₁ and VP₂ – which host the arguments of the verb. The lexical verb is generated in the head V position of VP₂, and selects NP₂ as its complement; these items merge to form a V' constituent. NP₁ is generated as the specifier of VP₂ (the inner subject), which together with the V' form a constituent – VP₂. Subsequently, the verb raises to the head position of the higher V' which is headed by an empty verbal head. This occurs because NP₁ carries an Accusative case feature which must be checked by the verb (Chomsky, 1992).²⁵ A checking relation is strictly local, and so a checking relation is only licensed when the verb is immediately left-adjacent to the accusative marked NP. This condition triggers the movement of the verb from its underlying position, left-adjacent to NP₂, to a position that is left-adjacent to NP₁ so that the Accusative case of NP₁ can be checked. It then moves to I where it acquires tense²⁶. The surface structure of a dative construction VP is thus derived by leftward movement of the verb which results in the basic linear order. It also provides the base structure from which a double-object construction is derived. Firstly, I illustrate a dative construction sentence in (74).

²⁵ It is not necessary to select a particular account of Case Theory here as it makes no difference to this stage of the review. What needs to be highlighted is that an NP having accusative case is the trigger for verb movement.

²⁶ In the specifier position of VP₁, the external argument is claimed to be generated. It is called an external argument as it is not contained within the maximal projection of V₁. This review is not concerned with the properties and behaviour of this argument. I will only state that following the Extended Projection Principle (EPP) of Chomsky (1982, 1995), a requirement in English that all clauses of declarative sentences have an overt subject, the external argument 'outer subject' does not appear as the specifier of VP₁ but as the specifier of the Tense Phrase (spec-IP).

(74) *John sent a letter to Mary*

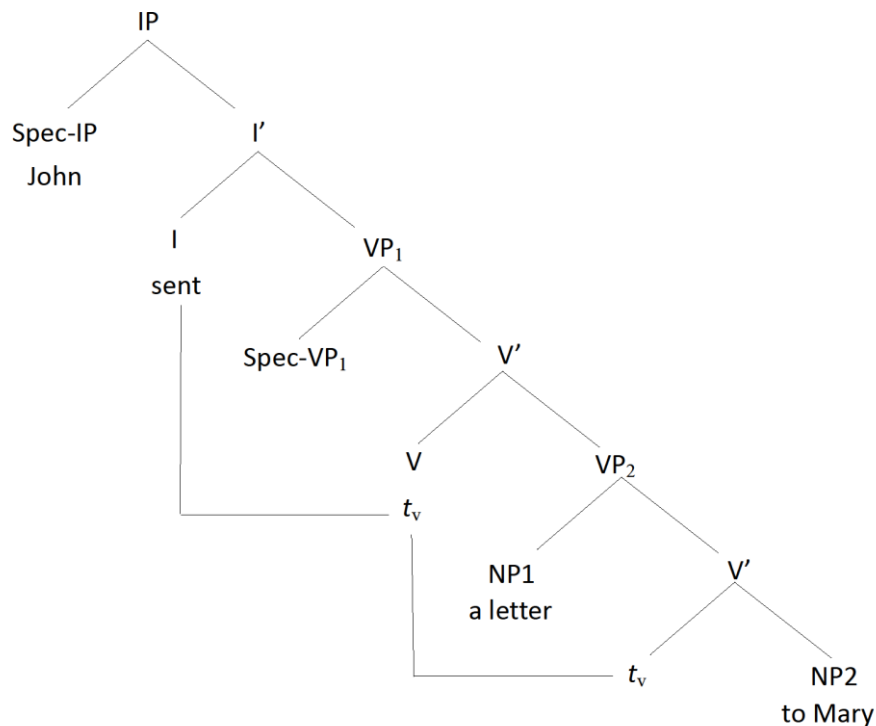

In (74), the verb *send* is generated in the head position of VP2. It selects *to Mary* as its NP2 complement. The argument *a letter* is generated in the spec-VP2 position. This argument has an accusative case feature, so the verb raises to the empty verbal head of VP1 which is left-adjacent to *a letter*. The accusative case-feature can then be checked. The verb moves again to the head of IP where it acquires *tense*. The ‘outer subject’ *John* appears as the specifier of the Tense Phrase (spec-IP). This gives the linear order for *John sent a letter to Mary*.

The framework for Larson’s analysis is based on Baker’s (1985) Uniformity of Theta Assignment Hypothesis (UTAH) coupled with the view of phrase structure set out in Kayne (1984). In UTAH, the way that theta roles are assigned by a verb is strictly uniform and this regulates how thematic roles are projected into the syntactic structure. This uniformity of theta role assignment in the syntax is regulated by a hierarchy of thematic roles which maps to syntactic structure. The repercussions of following UTAH are that there must be specific hierarchical positions in the syntax for the realisation of the relative hierarchy of roles such as *agent*, *theme*, and *recipient/goals*²⁷. Larson (1988) follows

²⁷ As we have seen, the view of thematic structure that is adopted here proposes that the syntax is not affected by such fine grained distinctions. It essentially conflates *recipients* and *possessors*, and does not distinguish between *recipients* and *goals/locations*. Therefore in the thematic hierarchy that is relevant to the syntax, they

Carrier-Duncan (1985) in proposing that *agents* are higher in the thematic hierarchy than *themes* which in turn, are higher in the hierarchy than *recipients/goals*. This means that when a verb projects these three roles, the *agent* is generated in the syntax in a structurally higher position than the *theme* which is generated in a position structurally higher than the *recipient* (spec-VP2) which is generated in the lowest position (complement of V2). This means that for the dative alternation, the thematic roles of the variants are identical and so must have an identical structure at their underlying level of representation. As we shall see, it is this strict approach to thematic structure that has led to a derivational account for the double-object construction. Kayne’s (1984) phrase structure rules set out binary restrictions on the merging of linguistic items. A head can enter into a spec-head relation with a single specifier (75a), and a head can select only a single complement as seen in (75b). In this way, a Vp-shell structure is forced as a verb can only appear as a head of a VP with two complements – limited to one in Spec-VP (75a), and one in the complement position (75b). In order to create a structure that can accommodate three arguments an additional layer is required.

(75)

a.

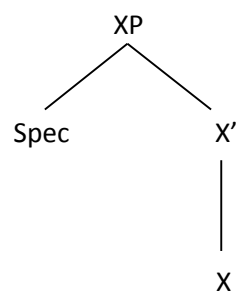

b.

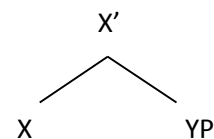

To generate the correct order for the double-object construction, Larson likens the operation of double-object construction formation to the formation of a passive construction. For Larson, the creation of a passive sentence like (76b) involves two main processes: the withdrawal of accusative case from the NP in object position and the special assignment of the thematic role linked to the argument in subject position.

are the same. Instead any difference that may exist between the linear position of a recipient and goal can be captured by resort to animacy.

- (76) a. Mary kissed John.
 b. John was kissed (by Mary).

In respect to the latter process, Larson (1988) proposes that rather than the traditional view that the thematic role of the argument in subject position in a passive is suppressed (Chomsky 1981; Burzio, 1986), the thematic role is assigned in a special adjunct configuration. The consequence of this type of thematic assignment is that the argument in subject position is ‘demoted’ from having argument status to that of an adjunct. This means that the argument in subject position (which is typically an *agent*) such as *Mary* in (76a) becomes optional. With respect to the withdrawal of accusative case, Larson (1988) articulates this as a suppression of the non-structural case assigned by the verb. Non-structural case is assigned to the semantically affected argument – which typically corresponds to the direct object in a transitive sentence (Baker, 1996).

The empty subject position triggers movement following the EPP requirement of English that all sentences require a subject. The object is not restricted from movement to this position because it does not rely on the verb to check a case feature, and so it is licensed to move. I illustrate this for (76b) in the tree structure of (77) (the symbol *e* signifies the position that the NP *John* would appear if its non-structural case was licensed by the verb).

(77)

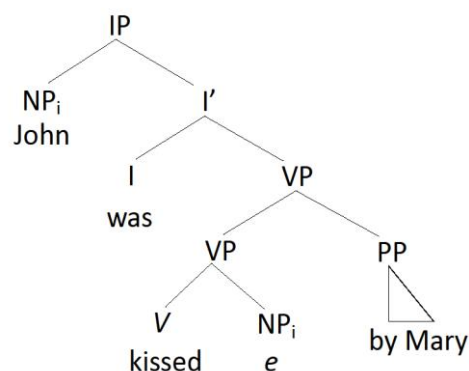

Larson claims that a very similar operation applies to transform the base form structure of (73) into a double-object construction. He calls this operation PASSIVE. This label is distinct from the lower case

'passive' which only refers to the passive formation of a sentence like (76b). PASSIVE refers to the operation which withdraws case from one argument and assigns in a special configuration the thematic role of another argument. This operation is available to whichever structure it can apply to.

The consequence of this operation to the formation of the double-object construction *John sent Mary a letter* is shown in (78) to (81). NP2 is the argument that has its case withdrawn. Larson (1988: 342) argues that the preposition *to* is governed by the verb and is an example of "pure Case marking" of dative case – a non-structural case²⁸. Viewing the preposition *to* in such a way is crucial as it allows the derivation of the double-object construction from its base structure to be assimilated to the derivation of a passive from an active construction. It also accounts for the absence of an overt preposition in the double-object construction as the pure case of *to* is absorbed by the verb (78).

(78)

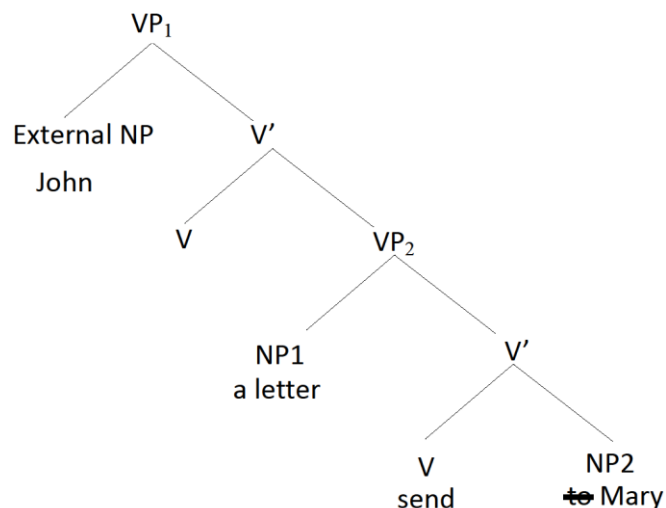

NP1 is the inner subject of the base structure, and it is this argument that has its thematic role assigned in a special way as a V' adjunct (79).

²⁸ It is standard to assume that there are two kinds of case-assignment: non-structural and structural case (e.g. Chomsky, 1986a; 1991). It has been argued that non-structural case can be sub-divided into lexical and inherent cases (cf. Woolford, 2006). It is proposed that both lexical and inherent cases behave alike but differ in properties of predictability, and the kind of theta positions to which they can be associated. For our purposes, this distinction is not crucial, and so I abstract away from this argument and use the general label *non-structural* case for both.

(79)

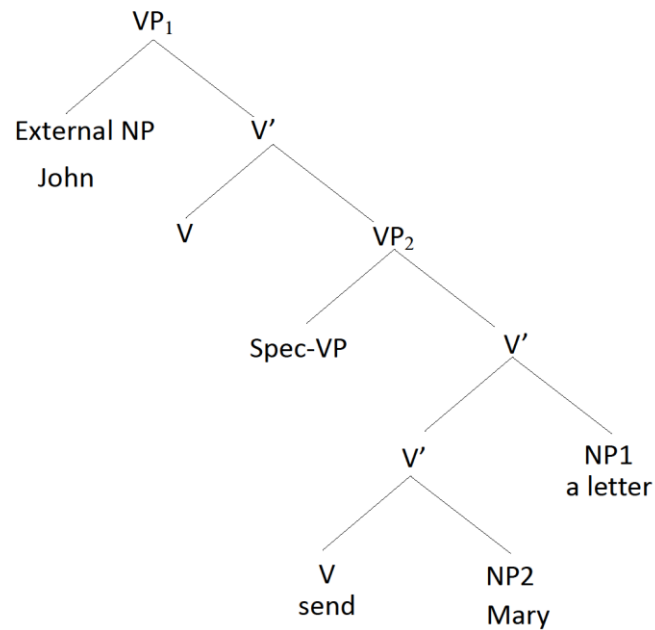

As in the passive, the NP2 is caseless in its base position and the inner subject position is non-thematic and hence empty. Movement of NP2 is then triggered in the usual way to the VP subject position. In the VP subject position, Larson (1988) claims that NP2 receives another case marker – structural accusative case (80). It is proposed that there are two sets of case assignment: one that is lexical and assigned by V in a complement position, and a second that is structural and assigned by I to the spec-VP position. The assignment of structural accusative case is ‘hosted’ by V, and so V indirectly assigns it.

(80)

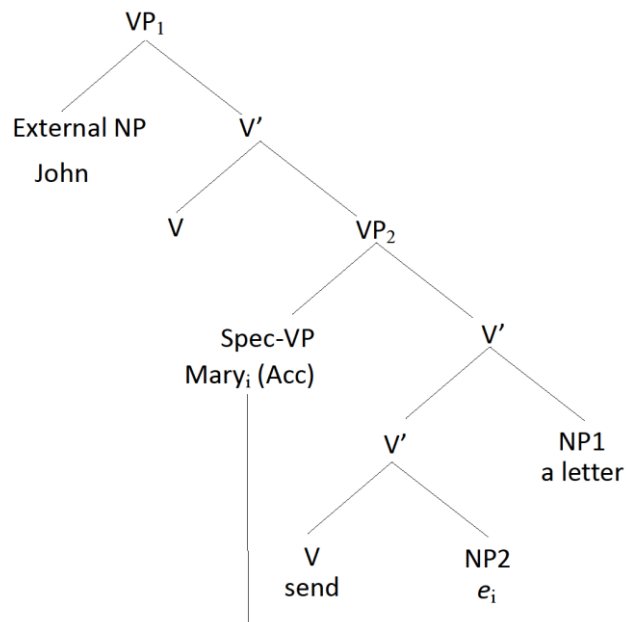

NP2 is therefore marked for accusative case which requires licensing. This triggers movement of the verb to the empty verbal head of VP2 so that it is left-adjacent to the accusative marked argument (81).

(81)

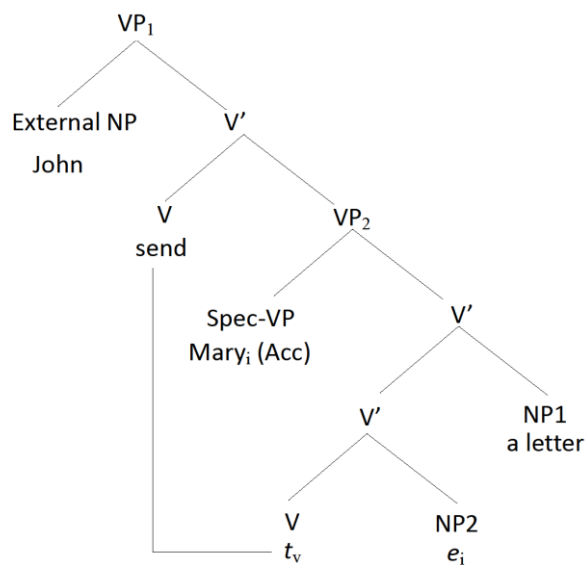

The verb then moves again to I where it receives tense. The argument in subject position then appears in spec-IP which gives the linear order for a double-object construction.

Having established a base structure for the dative construction, and the derived structure of the double-object construction, we can now account for the asymmetries observed in Barss and Lasnik (1986) to see how the Larsonian account fares. First we will look at reflexive binding, repeated below in (82).

(82) *Reflexive binding*

- a. I showed John_i (NP₁) to himself_i (NP₂) (in the mirror).
- a'. * I showed himself_i (NP₁) to John_i (NP₂) (in the mirror).
- b. I showed John_i (NP₂) himself_i (NP₁) (in the mirror).
- b'. *I showed himself_i (NP₂) John_i (NP₁) (in the mirror).

In the case of the dative construction, we saw that NP1 is generated in spec-VP2, and NP2 is generated as the complement of the head of VP2. In this structure NP1 is higher than NP2. This means that NP1 is now in a structural position to c-command NP2, as can be seen in (83) (only the VP structure is shown). As such, the Larsonian structure correctly predicts (82a) to be grammatical and (82a') to be ungrammatical.

(83)

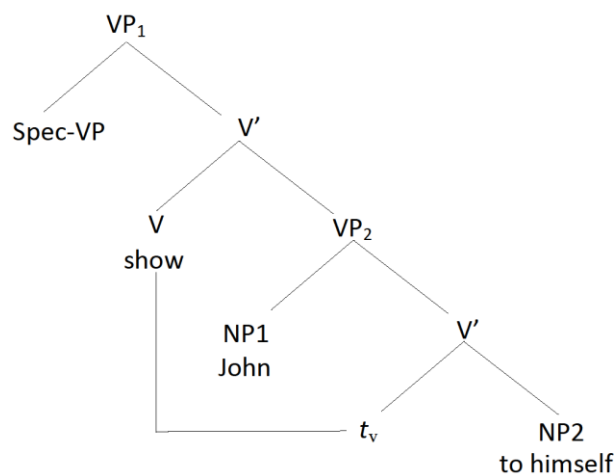

In the case of the double-object construction, after the movement of NP2 to spec-VP2 has been triggered, NP2 is in a structurally higher position than NP1 which now occupies an adjunction position to V', as can be seen in (83) (only the structure of the VP is shown). In this structure NP2 c-commands NP1. This structure correctly predicts (82b) to be grammatical and (82b') to be ungrammatical. The Larsonian structure also captures the restriction observed in weak-crossover (repeated below in (84)).

(84) *Weak crossover*

- a. Which worker_i did you deny *t* his_i paycheck?
- b. *Which paycheck_i did you deny it_i's owner *t*?

Recall, in order to achieve the coreferential meaning, the tail of the wh-phrase movement chain (*t*) must c-command the pronoun it is co-indexed with. In (84a) the tail of the wh-phrase chain appears in spec-VP2, and the NP1 pronoun it is co-indexed with appears adjoined to V'. Again, NP2 is higher than NP1, therefore *t* can c-command the pronoun, as shown in (85). Thus, the Larsonian structure correctly predicts (84a) to be grammatical and (84b) to be ungrammatical.

(85)

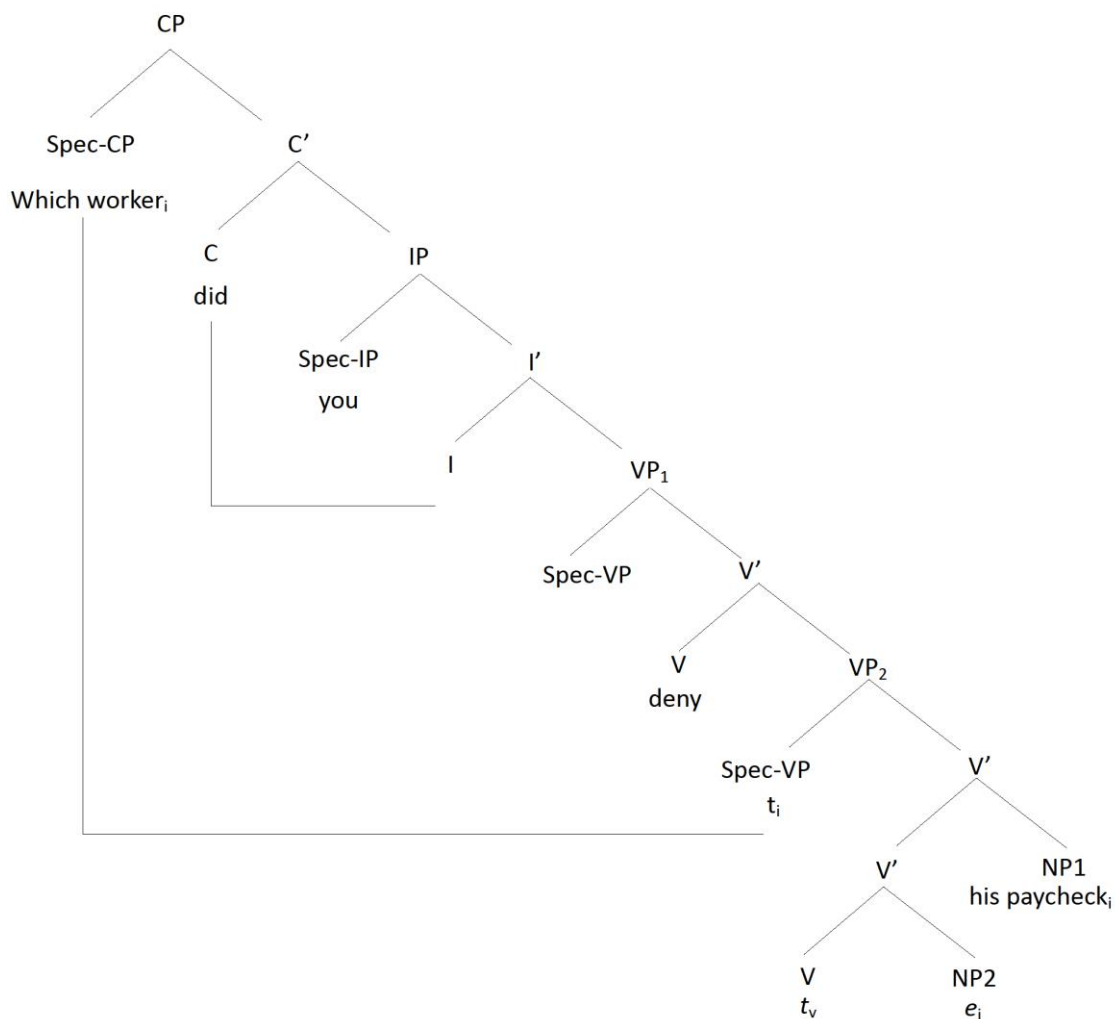

The Larsonian structure also correctly captures the *wh*-movement in Superiority, repeated below in (86).

(86) *Superiority*

- a. (Which book)_i did you give t_i to whom?
- a'. *(To whom) did Bill send which letter t_i?
- b. Who_i did you give t_i which book?
- b'. *(Which book)_i did you give who t_i?

Recall that in a sentence which contains two *wh*-phrases, only the structurally higher one can move to the left of the clause. In the dative construction in (86a), the NP1 *which book* is generated in spec-VP2, and NP2 *to whom* is generated as the complement of the head of VP2. In this case NP1 is structurally higher than NP2 and therefore can move to the left of the clause, whereas NP2 is blocked from this movement. The Larsonian structure correctly predicts this restriction. In the double-object construction in (86b), the NP2 *who* appears in the spec-VP2 position and NP1 *which book* appears as an adjunct to *V'*. Therefore NP2 is structurally higher than NP1 and can move to the left of the clause, whereas NP1 is blocked from movement. The Larsonian double-object structure correctly predicts this movement. The Larsonian structure also captures the asymmetry of NPI licensing, repeated below in (87).

- (87) a. I gave nothing to anyone.
 a'. *I gave anything to no one.
 b. I gave no one anything.
 b'. *I gave anyone nothing.

For the dative construction in (87a) the NP1 *nothing* is generated in spec-VP2 and NP2 *to anyone* is generated as the complement of *V*. Therefore the NPI is c-commanded by the negation. In (87a') the NPI *anything* is not in the c-command domain of the negation as it is generated in a structurally higher position than the negation in Spec-VP2. Once again, the Larsonian shell captures this asymmetry. For the double-object construction in (87b), the negation *no one* is NP2, which means it appears in the spec-VP2 position. The NPI *anything* appears as an adjunct of *V'* and therefore appears within the c-command domain of the negation. In (87b') it is the NPI that appears structurally higher than the negation and therefore cannot be c-commanded by it, just as the Larsonian approach permits.

2.11.3. Problems with Larson's analysis

As influential as Larson's analysis of the VP was for a formal account of this phenomenon, it is not without its problems. The association of c-command and scope are a particular case in point. Scope interpretation tends to coincide with the surface c-command domain of an operator (e.g. Janke and

Neeleman, 2012). In other words a quantificational item which is structurally higher than other material can take scope over that lower material iff it is within its c-command domain. So for a uniform VP-shell analysis for the English VP one would expect a default left to right scope reading between two object arguments if the leftmost object is a quantificational noun phrase (QNP). This is because it is in a structural position that c-commands the rightmost NP. This means that in the double-object construction, a universal quantifier in NP2 cannot be scopally dependent on an existential quantifier in NP1. This is referred to in the literature as Scope Freezing (Aoun and Li, 1989). This is illustrated in (88).

(88) [TP John [VP2 sent [VP1 every student [V' t_v a book]]]] $\forall > \exists$ ²⁹

The reading for (88) is that books were sent out such that each and every individual student received a different copy of a book; rather than same book circulating around to each student. This is captured by the structure for the double-object construction in (89). The QNP *every student* takes scope over *a book* which coincides with its c-command domain.

²⁹ In this example the article 'a' is indefinite. It is however possible for an indefinite to be specific which would result in a different reading ($\exists > \forall$). We abstract away from this issue here and focus on the narrow reading.

(89)

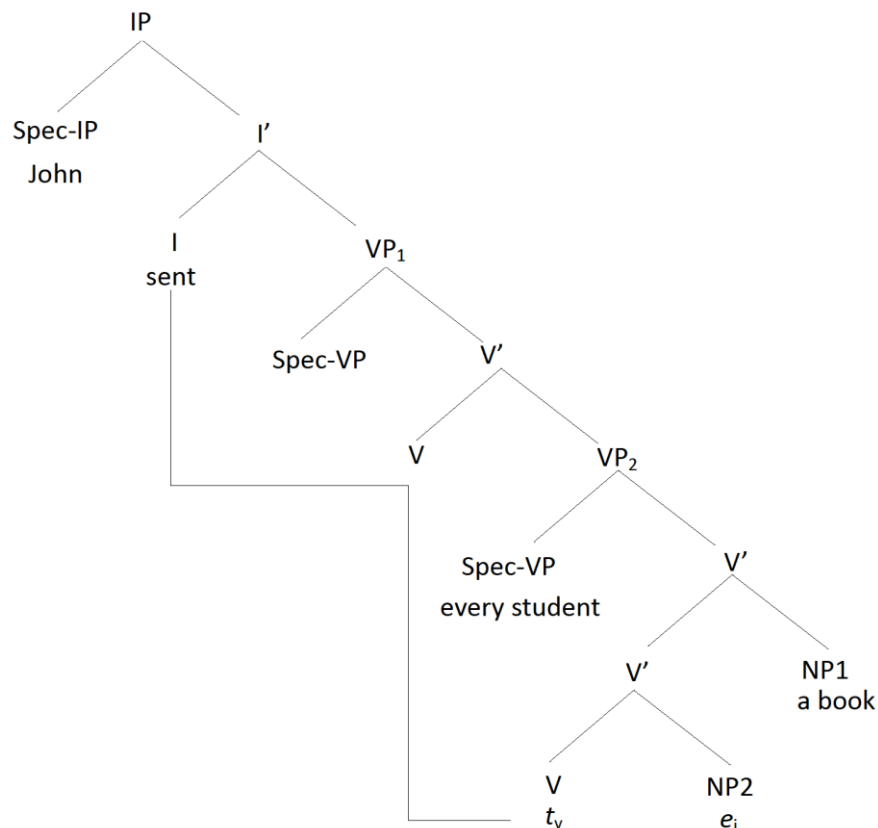

If a Vp-shell analysis was uniform for all double-complement structures then we would also expect to see default left to right scope in the dative construction. However this does not seem to be the case as can be seen in (90).

(90) [TP John [VP2 sent [VP1 every book [V' tv to a student]]]] $\exists > \forall \gg \forall > \exists$

In (90) the interpretation is ambiguous. A reading where the existential has scope over the universal is the preferred one – John sent one particular student every book. However, a reading where the universal has scope over the existential is also possible but such ambiguity cannot be accounted for in the strictly descending structure of Larson if c-command is the governing factor (Stroik, 1996).

A further problem for a uniformly descending structure is documented in Pesetsky (1995). Pesetsky noticed that certain binding data suggested that the English VP had a Larsonian structure, whereas

standard tests of constituency suggested that a Chomskyan structure was appropriate as in (91). The paradox results from the incompatibility of binding data with the two widely held assumptions: (i) binding requires c-command; (ii) only constituents can move. This became known as Pesetsky's Paradox.

(91) John intended to give the book to the children, and [_{VP} give the books to *them*_i] he did on *each other*_i's birthdays.

(Pesetsky, 1995: 230)

The dative construction in (91) involves an anaphoric dependency between *them* and *each other*. If c-command is the determining factor that captures binding phenomena then in order to capture this dependency, *each other* must occur in a structure in which it is structurally lower than *them*. This requires a descending structure so that *each other* can be in a structural position to be c-commanded by *them*. This means that the PP *on each other's birthdays* cannot be adjoined as an adjunct to VP2 but must be contained within the VP constituent that contains *them*, as the simplified tree in (92) shows.

(92)

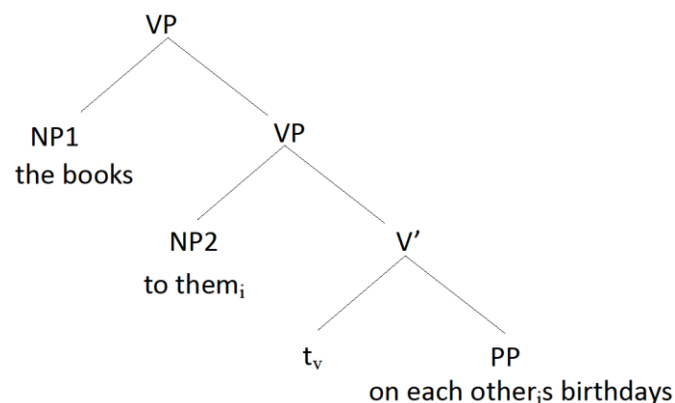

The paradox becomes clear when we see that the topicalised constituent in (91) *give the books to them* can strand the PP *on each other's birthday*, which means the PP is not included in the constituent and can only be parsed using a Chomskyan structure as shown in the simplified tree in (93).

(93)

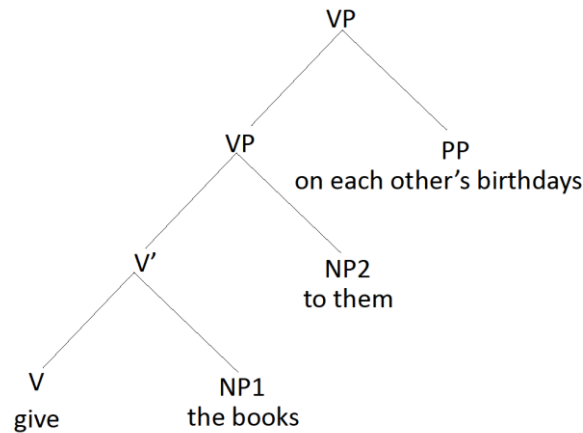

Pesetsky (1995) resolved this problem by resorting to a dual system which relates a single surface string to two distinct phrase structures – an ascending structure and a descending structure. The former he calls a Layered structure and the latter a Cascade structure (cf. Pesetsky, 1995). Although Pesetsky's proposal can account for the empirical facts, it faces two problems. Firstly it cannot explain why the phenomena are distributed in this way – why is binding restricted only in a cascade structure and not in a layered structure. Secondly, Pesetsky's proposal weakens the standard assumption that unambiguous strings are mapped onto a unique structure (e.g. Bresnan, 1982b). A dual structure would suggest that all strings have the potential for ambiguous readings. It can also not predict which reading would then emerge. Because of this, the motivations behind the structures become arbitrary. Janke and Neeleman (2012) claim this problem can be resolved if the presence of two competing and separate structures are posited. It is to this account of the English VP that we now turn.

2.12. Ascending and descending verb phrases in English

Janke and Neeleman (2012) (JN hereafter) represents an attempt to reconcile the conflicting data. JN claim that a Larsonian type structure does indeed exist for the English VP but unlike Larson (1988) and others, they propose that this is not the only possible structure. They suggest that the English VP can be derived by a traditional Chomskyan ascending structure as in (94) and a Larsonian type descending structure as in (95), but not both simultaneously. JN's account of a descending structure differs from Larson in that the VPs' arguments are not transformed from one base structure, but rather are generated differently. An occurrence of a double-complement construction can have either of these structures, dependent on certain conditions, but it does not have access to both as suggested by Pesetsky (1995). This proposal for the structure of the English VP forms part of a wider program that views syntax as more flexible (Neeleman and Weerman, 1999) with a paradigm of mirror-image structures available to the syntax (Abels and Neeleman, 2009).³⁰

(94)

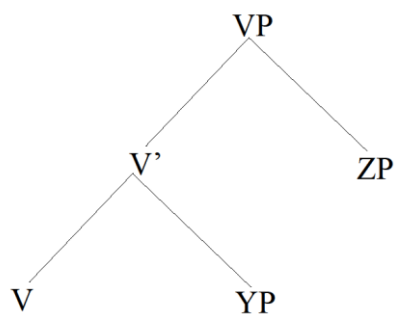

³⁰ Flexible Syntax forms an interesting program in syntactic theory that would require significant space to expand upon which ultimately would detract us from the topic at hand. This program has also provided a theoretical base for an account of the universal internal-ordering of noun phrase material observed in Greenberg's (1963) Universal 20. The reader is directed to Abels and Neeleman (2009; 2012) for exposition of this argument.

(95)

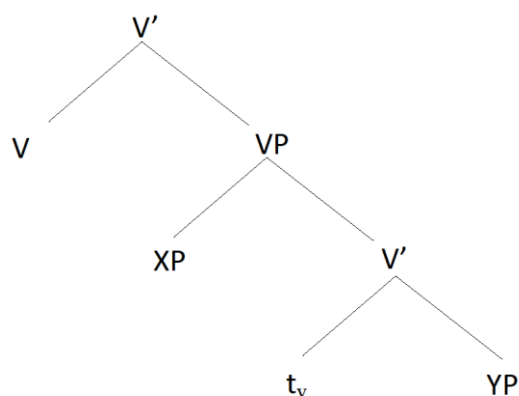

In this subsection, it will be demonstrated that this theory provides correct predictions for data on scope, binding and constituency, which have eluded a single-structure account. It is a Case-based account, which attributes the presence of a VP-shell in English to a strategy that seeks to ‘repair’ a VP in order to satisfy a condition on the licensing of arguments, namely Case Adjacency³¹ as given below in (96).

(96) *Case Adjacency*

- a) A case-marked DP cannot be preceded by any XP in its case domain.
- b) The case domain of a DP consists of the DP itself and any constituents linearly intervening between the DP and the head licensing its case.

This definition of Case adjacency triggers the selection of a descending structure if any material intervenes between a verb and an accusative marked NP. This is because any material that intervenes blocks the licensing of the NP’s accusative Case. Recall, that accusative Case is only licensed when a

³¹ JN point out that this particular definition of Case Adjacency allows the intervention of material in OV languages between the object and the verb, and so can account for scrambling phenomena in languages like Dutch. Although such a definition of Case Adjacency is significant for the larger program of Flexible Syntax, an account that allows scrambling in such languages is not of particular significance to this thesis.

verb is left-adjacent to an accusative NP. Therefore, in order for Case to be assigned, V and an NP must be adjacent to each other as can be seen in (97).

(97) a.

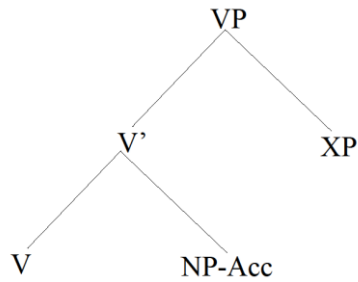

b.*

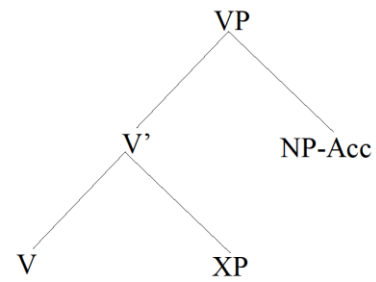

In an ascending structure, if the accusative DP is not adjacent to the verb, as in (97b), then a repair strategy that generates a Vp-shell to rescue the string is forced as in (98). But if an accusative DP is merged into the syntax next to the verb (97a) then no repair strategy is needed and an ascending structure suffices. So crucially, both structures are not simultaneously ascending and descending, the selection of one over the other is driven by Case Adjacency.

(98)

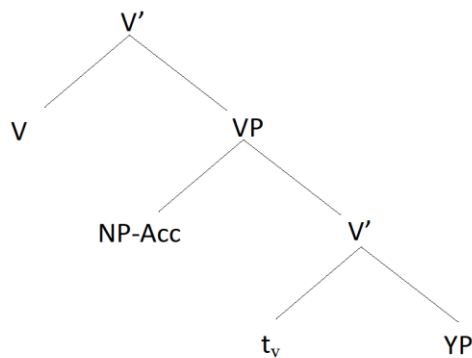

Such a view on structure is regulated by an Economy condition on the syntax which JN formulate as follows:

(99) Economy

- a. Two structures are in competition if and only if (i) they are well-formed, and (ii) they are characterized by identical hierarchical relations, except for those hierarchical relations created by movement.
- b. From a set of competing structures, choose the one with the fewest movements.

(Janke and Neeleman, 2012: 154. Their 6.)

This means that for reasons of Economy the default structure for English double-complement structures is the Chomskyan ascending structure as it contains the fewest movements. This structure will be forced in all cases where the NP does not rely on the verb for Case, and so does not need to be adjacent to it in the derivation. One such example is a double-complement that has two PP arguments (from here on 'double-PP') as in (100).

(100) John talked about journalism with Mary

(Janke and Neeleman, 2012: 156. Their 9c.)

In a double-PP neither argument is assigned accusative Case, so Case Adjacency between verb and argument does not apply to a double-PP string. This means that in a double-PP construction the order of the internal arguments is free, and so no descending structure is forced.

(101) a.

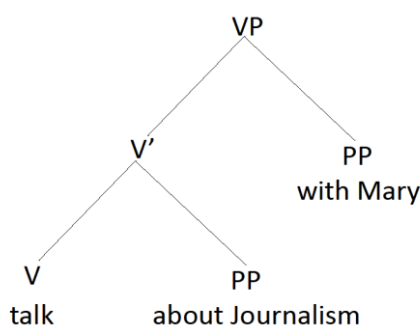

b.

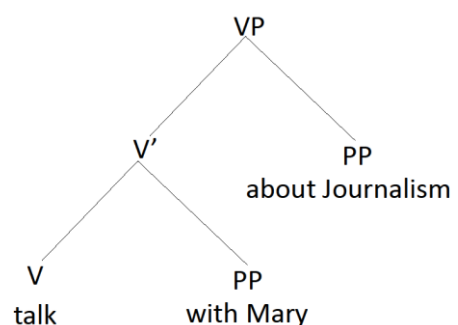

In opposition to the structure for a Double-PP, JN claim that the double-object construction is forced consistently into a Vp-shell, as both internal arguments rely on the verb to check their accusative Case feature. For a double-object construction, at some point in the derivation the verb and the accusative marked NPs must be adjacent to each other for case-checking purposes. In order for this configuration to be obtained, the verb undergoes movement. It originates in the head of the lower V in a position left-adjacent to the accusative marked NP2, and then moves up and left to the empty V so it is left adjacent to the accusative NP1, as illustrated in (102). The trace of the verb in the lower V head can license Case (e.g. Koopman, 1987; Chomsky, 1995; a.o.) for NP2.

(102)

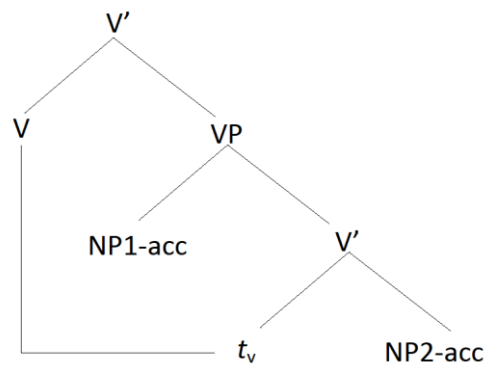

Recall that in the traditional Larsonian structure, two levels of Case assignment are required – one assigned by the verb, and another assigned through the verb by I. Resorting to this view of Case forces movement of the argument and the verb in the double-object construction. Structural Case is obligatorily assigned to some NP following standard assumptions of Case assignment conditions (Chomsky 1981, 1986), hence an argument must move to receive this Case feature. The verb then moves obligatorily to a left-adjacent position to the Case marking node. In this way, the argument that has received the Case feature can have that feature licensed. In JN's proposal, as both internal arguments are base-generated in the positions in which they appear, the complication of adding an additional level of Case assignment and requiring complex movements of elements is not required, and a more economical structure is created. A descending structure, where the arguments are base-generated, is then more economical than a standard Larsonian analysis. It is the most economical structure to achieve this double checking of accusative Case as only one element – the verb – need move.

2.13. The general pattern for anaphoric dependency

For the dative construction, we saw that an ascending structure could not capture the binding dependencies in Barss and Lasnik (1986). Therefore, to propose the presence of an ascending structure for a dative construction requires a reformulation of the standardly assumed conditions on Binding. One proposal for this is Williams' (1997) General Pattern for Anaphoric Dependency (GPAD). Williams (1997) identifies two ways that a pronoun can be licensed by an antecedent. Firstly, the antecedent can precede the pronoun as shown in (103a) and (103b). Secondly, the pronoun can occur in a subordinate clause that is subordinate to the clause containing the antecedent, as in (103c). When neither of these conditions is met, the relation cannot be established (103d). (Term Paper is capitalised to show that it has the main stress of the sentence. This guarantees that it is not an anaphoric element from a previous mention in the discourse.)

- (103) a. Anyone [who has written his term paper_i] can turn it_i in to me now.
b. Anyone can turn his term paper_i in to me now [who has written it_i].
c. Anyone [who has written it_i] can turn his term paper_i in to me now.
d. *Anyone can turn it_i in to me now [who has written his TERM PAPER_i].

(Williams, 1997: 587. His 22.)

GPAD implies that when a dependent category is not contained in a subordinate clause to the antecedent then it must at least follow the antecedent to establish a coreference between them. For the Barss and Lasnik effects, this means that an ascending structure can still capture the binding relation between the objects if a coreference can be established in terms of precedence of the antecedent. I will illustrate this only with reflexive binding, although this can be applied to all of the Barss and Lasnik effects (cf. Williams, 1997). In (104a) the NP1 antecedent *John* precedes the NP2 reflexive that it is coreferenced with. In an ascending structure, NP1 is structurally lower than NP2, but the GPAD condition of precedence is met, and so the relation can be established. However, in (104b), the NP1 reflexive precedes the NP2 antecedent and it is also contained within the same clause. In this example, neither of the conditions is met, and so coreference cannot be established. In (104c), the NP1 antecedent precedes the reflexive, and the reflexive is within a subordinate clause that is

subordinate to the clause containing the NP1 antecedent, so the GPAD conditions are both met and the coreference is established. In (104d), the reflexive precedes its antecedent but it is contained within a subordinate clause that is subordinate to the clause containing the NP2 antecedent. Therefore, only one of the GPAD conditions is met but this still allows the coreference to be established.

- (104) a. I showed John_i (NP₁) to himself_i (NP₂) (in the mirror).
b. *I showed himself_i (NP₁) to John_i (NP₂) (in the mirror).
c. I showed [the baby_i [who was cooing to himself_i]] (NP₁) to Mary (NP₂).
d. I showed [a picture [of himself_i with his family]] (NP₁) to John_i (NP₂).

By resorting to GPAD, the Barss and Lasnik effects are weakened, which suggests that the motivation for a descending structure is also neutralised. If precedence is a determining factor, then a structure such as Larson's, where an antecedent c-commands an anaphoric element, is not required. However, other evidence presented in JN suggest that a Larsonian-type structure is still correct for the double-object construction. A case in point is the distribution of Floating Quantifiers (FQs). This is an instance of a quantifier appearing separated from its quantified argument (Bobaljik, 2003). A sentence that exhibits this separation of argument and quantifier, as in (105b), is a paraphrase of a sentence where the quantifier is not separated from its argument, as in (105a) (e.g. Kayne, 1969; 1975). The quantifier is called *floating* as early proposals took the quantifier to be floating rightward away from its argument (Maling, 1976).

- (105) a. All the students have finished the assignment.
b. The students have all finished the assignment.

(Bobaljik, 2003: 129. His 45.)

JN claim that the distribution of FQs associated with an NP2 argument in a double-object construction are indicative of a descending structure. In their proposal, JN analyse FQs as adverbial elements that precede the verbal category to which they attach, and that are linked to an unassigned theta-role. The left-attachment of an FQ to an XP is assumed by many researchers (e.g. Baltin, 1978; 1982, 1995; Bobaljik, 1995; Doetjes, 1997). This is illustrated in (106).

(106)

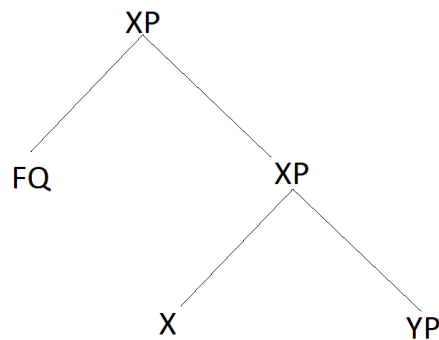

The association with an unassigned theta-role is based on a system of theta role assignment where theta roles are projected by the verb, and unassigned theta roles percolate up through the syntactic structure until they are assigned (Neeleman and Van de Koot 2002; 2010). The theta role is subsequently assigned to an argument in a sister relation with a local verbal node.³² This is illustrated in (107). In (107), V has two theta roles that must be assigned (θ_1 and θ_2).³³ θ_1 can be assigned to the YP argument as YP is a sister to V. θ_2 is not assigned at this point and so percolates up to V'. Here V' is in a sister relation with the XP argument, and so can assign θ_2 to XP.

³² In Neeleman and van de Koot (2002; 2010), the theta role is assigned under immediate domination. We follow Janke and Neeleman (2012) and show an assignment as a sister relation for simplicity as nothing hinges on this.

³³ The numbering of theta roles is used for descriptive purposes; it is not intended in any way to suggest a specific ordering of roles in the structure.

(107)

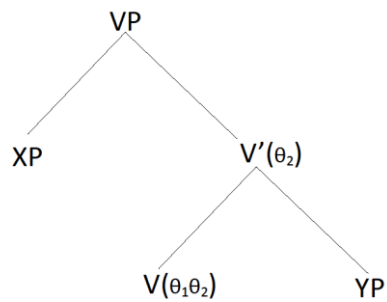

A floating quantifier can be associated with an unassigned theta-role when the unassigned theta role has percolated up from V to a verbal node, and the FQ is a sister to that verbal node. This is illustrated in (108) for the sentence *the boys both sit the exam*. (The association of the FQ and the unassigned theta-role is marked with superscript).

(108)

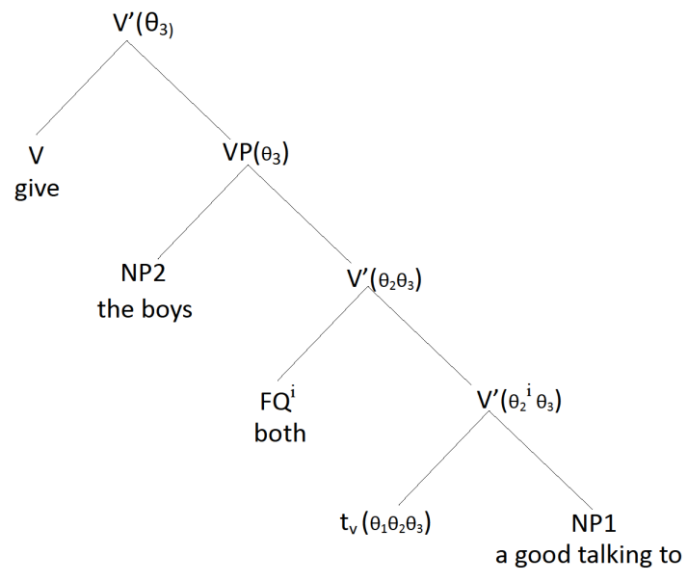

As can be seen in (108), the FQ *both* precedes the verbal category to which it is attached. It is associated with the theta-role that will be assigned to the argument in subject position *the boys*. This theta role percolates up from V, through VP to I' where *the boys* can be assigned the theta role in a

local configuration – sister to I'. Because of this process, *the boys* is interpreted as the antecedent of *both*. An ascending structure cannot account for this as (109) and (110) illustrate.

(109) *[The boys]_i sit the exams both_i

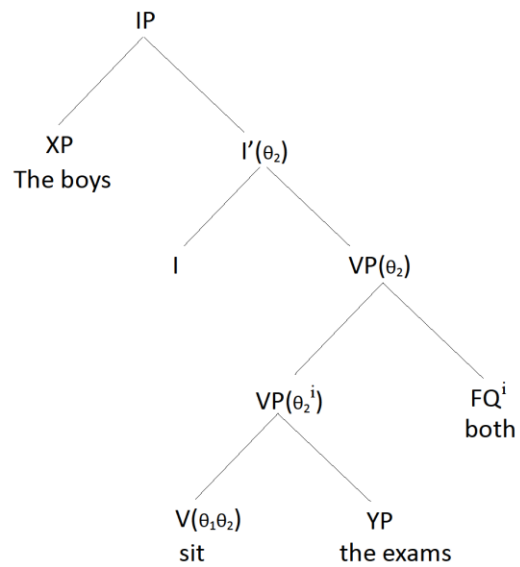

(110) *The boys sit [the exams]_i both_i

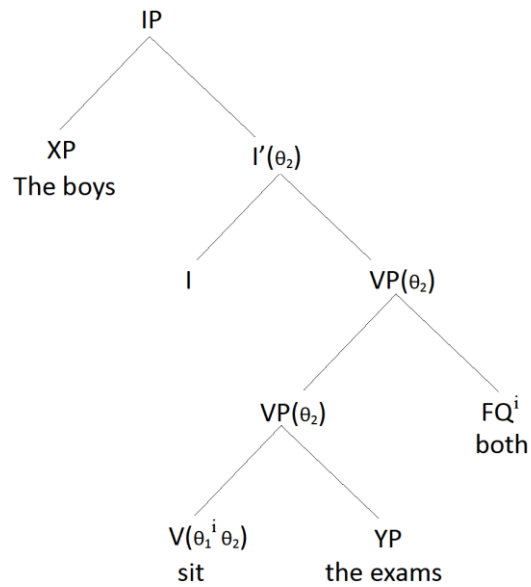

In (109), the FQ is not licensed as it follows the category to which it is attached. In (110) the FQ cannot be associated with *the exams* as it does not precede the respective category, and it cannot be associated with the theta role that has already been assigned. For a double-object construction, an FQ can be associated with an NP2 as shown in (111).

(111) I gave the boys both a good talking to.

(Janke and Neeleman, 2012: 164. Their 35.)

The FQ can only be associated with NP2 if it is linked to the unassigned theta role intended for NP2, and it precedes the verbal category to which it is attached. This is illustrated in (112) (only the VP string *give the boys both a good talking to* is shown).

(112)

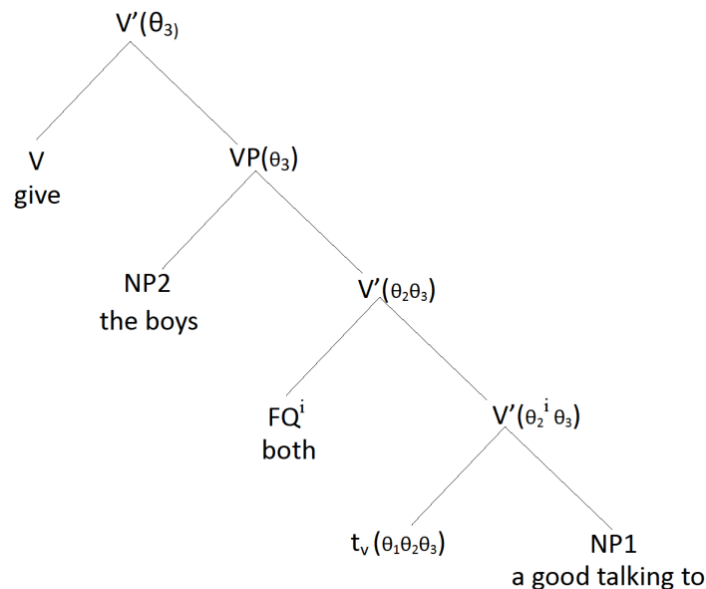

This evidence shows that a double-object construction does indeed have a descending structure if it can admit an FQ. Further evidence for a descending structure comes from scope interpretations. Recall that surface scope interpretation regularly coincides with c-command. Additionally, a double-

object construction is subject to a scope freezing effect. If scope does coincide with c-command in the double-object construction, we must assume that a quantifier in the specifier of the lower VP must take scope over a quantifier in the lower VP complement position, as in (113).

(113) I gave a child every gift. a > every, *every > a

The only possible reading is where there is only one child who receives all of the gifts. This occurs because the specifier of the lower VP c-commands the lower VP complement. In an ascending structure, *a child* does not c-command *every gift*. As such, a distributive reading where a number of children have received all the gifts is impossible. This means if surface scope and c-command coincide then only a descending structure can capture this relation. This evidence together with data from floating quantifiers strongly suggests that the double-object construction has a descending structure.

I have presented the model of double complement structures of Janke and Neeleman (2012). I also highlighted the problems found with the single structure approaches of Chomsky (1981) and Larson (1988). I showed that neither an ascending nor a descending structure accounts for the data independently, and only by resorting to the dual structure approach can all of the data be adequately captured. An important aspect to the JN approach is that the structures are both base-generated and are not derived from one another. This provides the correct structures to uniformly integrate the order of feature clusters of the Thematic Hierarchy that I gave in (2.9) into the constructions of the spray/load and dative alternations. Only a non-derivational approach is able to respect the ordering of values along the hierarchy which I now illustrate in the following section.

2.14. The feature cluster hierarchy and double-complement structures

Recall that thematic structure is encoded as a set of binary features which encode whether a participant in the event has a causal role (/+c) or not (/–c), and the mental state of participants (/+m or /–m). A cluster can combine a value for both of these features or leave a feature underspecified. These features are uniformly ordered along the hierarchy proposed in (54). In the hierarchy, the [–c] cluster (non-causal) is structurally superior to [–c –m] (non-causal with mental state not relevant to the interpretation of the event). The [–c –m] cluster is also the structurally lowest member of the

hierarchy³⁴. In order to have a uniform mapping of thematic feature clusters with the syntax for double-complement structures, the [-c] cluster must consistently be mapped to a structure in which it is structurally higher than [-c -m]. Only the presence of two syntactic structures can account for this. In the strictly ascending structure of Chomsky (1981), the structurally lowest NP always corresponds to the linearly leftmost object NP. In a dative construction, its thematic grid can be mapped to the structure in line with the order that these clusters appear on the Theta Cluster Hierarchy. In (114a), the [-c -m] cluster is mapped to the lower NP and the [-c] cluster is mapped to the structurally higher object position. This follows the ordering of the hierarchy. In the double-object construction in (114b) the [-c] cluster attaches to the lower NP and the [-c -m] cluster is mapped to the higher object position. This is in contrast to the hierarchy. Recall that the tests for the structure of a double-object construction show that a *theme* (NP1) cannot be structurally higher than a *goal* (NP2).

(114)

a.

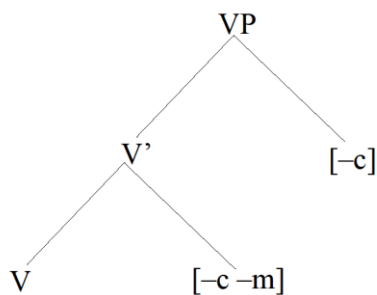

b.*

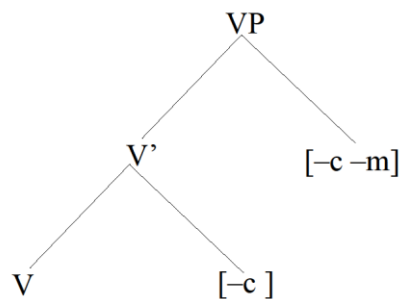

A Larsonian derivational analysis fares no better. This account provides an incorrect mapping of theta clusters to structure for both a dative construction and a double-object construction. In a Larsonian base structure the [-c] cluster consistently maps to a position lower in the structure than the [-c -m] cluster in both the dative construction and the double-object construction. As theta clusters are the input to the syntax, these clusters must have the correct mapping to the base structure. However, in (115a) the [-c] cluster maps to the VP2 complement position of Larson's (1988) base structure. The

³⁴ We shall see later that [-c -m] is not the correct cluster for the NP1 in the spray/load alternation. However, we reserve the argument for this adjustment until (2.17.3).

[-c -m] cluster maps to the higher position of spec-VP2. In (115b), the [-c-m] cluster has had its theta role 'specially assigned' as an adjunct to V'. This position is still structurally higher than the position that [-c] is mapped to. This still does not conform to the hierarchy.

(115)

a. *

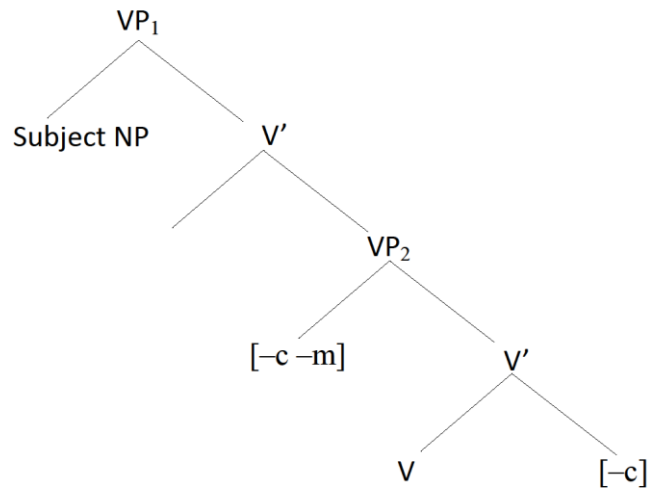

b. *

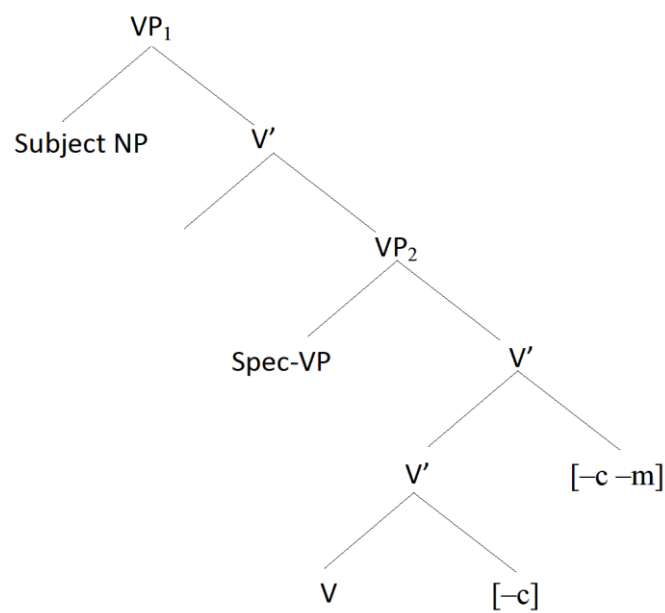

The only analysis that provides the correct mapping is the base-generated dual structure account of Janke and Neeleman (2012). As we saw in (114b) the correct structure to capture the mapping of theta clusters for the dative construction is the ascending structure. This is one of the structures used in Janke and Neeleman’s (2012) account. The mapping of the theta clusters for the double-object construction is also correctly captured by the base-generated descending structure, as I now show in (116). In the base-generated structure, $[-c -m]$ consistently maps to the complement of the lower VP and $[-c]$ maps to the specifier of the lower VP. This position is structurally higher than $[-c -m]$.

(116)

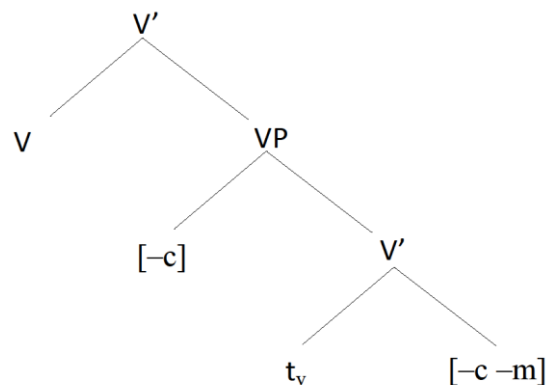

What is interesting here is that the Feature Cluster Hierarchy is blind to linear order. On the ascending structure, the cluster $[-c-m]$ maps to the complement of the lower V. This position is the same for the descending structure. On the ascending structure, the $[-c]$ cluster maps to a higher structural position than the $[-c-m]$ cluster. This position is linearly to the right of $[-c-m]$. Contrastingly for the descending structure the $[-c]$ cluster maps to a higher position than $[-c-m]$. This position is linearly to the left of $[-c-m]$. This suggests that linear order is not a defining factor of the hierarchical relations of theta clusters. If the linear order is not a result of the thematic mapping then the trigger for linear order must lie elsewhere. This is important for section (2.18) when the interaction of contextual factors and word order is discussed. What it does mean is that we have a uniform mapping of positions on a hierarchy to positions in the syntactic structure. A relation where cluster A is higher on the Theta Cluster hierarchy than cluster B means that cluster A will map to a position structurally higher than cluster B, irrespective of the linear ordering of the syntactic positions. To summarise, the JN model of double-complement structure provides two distinct syntactic structures – a Chomskyan ascending structure and a Larsonian-type descending structure. The former applies to the structure of the dative

construction³⁵, and the latter to the structure of the double-object construction. Both of these proposed structures are generated independently. The arguments are base-generated and so no movement from an underlying level of representation is necessary. For reasons of economy, this base-generated dual-structure account captures the facts without placing additional computational burden on the syntax, unlike the derivational account of Larson (1988) among others.

In the first part of this chapter, I have reviewed a historical development of the double-complement structures from the original proposal for an ascending structure in Chomsky (1981) to a theoretical shift to a descending structure of Larson (1988). It was shown that the original Chomskyan structure could not capture asymmetries observed between the dative and double-object constructions. Larson's analysis was an attempt to capture these asymmetries. His original proposal posited a base structure from which the surface structures of the dative and double-object constructions were derived. This transformation required the movement of arguments as well as verbal material. We then progressed to the dative construction, where Pesetsky's paradox suggested that evidence from VP fronting required an ascending structure, while binding data pointed to a descending structure. It was demonstrated that by incorporating the General Pattern of Anaphoric Dependency of Williams (1997), the binding data could be accounted for, which meant that an ascending structure for the dative construction was still possible. Finally, we turned to the model of Janke and Neeleman (2012), which proposed that an ascending structure for the dative construction did exist, whilst a double-object construction had only a Larsonian-type descending structure. This theory proposed that each structure exists independently, and the structures themselves have base-generated arguments.

It is this framework that will be adopted in this thesis. This is for two important reasons. Firstly, having been used successfully on a series of double-complement structures, it provides us with a means of testing the structure of the constructions in the spray/load alternation, which is the primary goal of this thesis. Secondly, it will be shown that this dual-structure account is compatible with the incremental processing approach adopted in this thesis. It is also compatible with the semantics of the spray/load alternation reviewed in (2.15). The Construction Grammar approach, however, which proposes that each construction in an alternation is independent and has a distinct meaning, will ultimately be questioned. This is difficult to reconcile with a transformational account as by their very

³⁵ It should be noted that in a dative construction, JN argue that this construction has an ambiguous structure. As to which structure is projected depends upon material that may intervene between the verb and the accusative NP1. In all other cases an ascending structure is forced for reasons of economy given in (100). As this data ultimately detracts from our analysis of the spray/load alternation, I refer the reader to Janke and Neeleman (2012) for development of this argument.

nature, the structures in a transformational account cannot be independent (Goldberg, 1995). Although, ultimately I will highlight the problems inherent to the CxG approach before any consideration of context, the fact that the constructions in this approach are associated with independent meanings means that they must also be generated independently. Discussion now turns to the semantics of the constructions of the spray/load alternation as proposed by the Construction Grammar of Goldberg (1995).

2.15. Semantics and Construction Grammar

This section focuses on the dominant contemporary analysis of the structures of the spray/load and dative alternations. This is known as Goldberg's (1995) Construction Grammar approach (CxG hereafter). The central idea is that there are large numbers of grammatical units called 'Constructions' which are basic forms that are used to express meanings. For Goldberg (1995), the general meaning of a sentence is derived by an interaction of a construction and its verbal material. This is illustrated in (117) with the so-called *way* construction. The sentence implies that Frank managed to get to New York. The claim is that semantics of *find* cannot account for the sense that Frank travelled along a path designated by the prepositional phrase (to New York); there is nothing about the meaning of *find* that implies motion.

(117) Frank found his way to New York.

(Goldberg, 1995: 199. Her Chapter 9, example 2.)

For the spray/load and dative alternations, each variant is also an independent pairing of a construction with a single verbal entry. A variant is not the result of a transformational process which derives one variant from the other. CxG attempts to explain differences in the interpretation of each of the variants in an alternation which cannot be entailed solely from the meaning of a single verb entry. For example, the verb *get* in (118a) describes an event which involves the subject *Sam* coming to possess *a cold*. There is no implication that any motion extending from the subject has taken place, although this is a possible reading of (118b). Moreover, there is no implication that *Sam* has received the *cold* on behalf of some other party although this is a possible reading of (118c). Goldberg (1995)

claims that examples like (118) show that these readings are only available from the constructions with which the verb appears.

- (118) a. Sam got a cold.
b. Sam got the package to Bill.
c. Sam got Bill a present.

As such, CxG abstracts away from the lexically driven view that an alternation is actually the result of multiple homophonous verb entries, each with its own distinct sense and conventionalised subcategorisation frame (e.g. Gropen et al., 1989; Pinker, 1989). CxG takes the view that a set of constructions with the same form does not consist of independent entities that exhibit irregular organizational patterns, but are instead a “highly structured lattice of interrelated information” that “display prototype structures and form networks of associations” (Goldberg 1995: 5). What appear to be instances of constructions of a similar type is in fact a multiple instance of the same construction. This is because they display broad generalities in form and meaning that suggest that they are in fact the same construction. A single surface form equates to a single construction. A construction exists independently of a verb and is not part of a lexically determined argument structure. A construction contributes a meaning to a sentence that is independent of verb meaning although as we shall see they have to be compatible. On first glance, it appears that the CxG approach is compatible with the view of the spray/load alternation taken in this thesis. Firstly, it views each verb/construction pairing as independent and not derived from the other which is compatible with the syntactic account given here. Secondly, the structure of the construction determines the interpretation of the thematic roles that participants can play in an event. This suggests that in principle CxG is compatible with the Theta System given in (2.6). The verb is free to profile a single set of feature clusters, and these clusters can be mapped independently to a construction frame to give them a particular interpretation in that structure such as *agent*, *patient*, and so on. It also means that a particular cluster can be associated with different interpretations depending on the kind of construction that the verb is paired with. The fine-grained thematic role distinction (e.g. *recipient/possessor/goal*) is represented in a construction’s architecture. Thirdly, CxG does not reject outright the effect that context may have on sentence form, which is an important factor of the current analysis, although the effect of context is highly constrained. CxG greatly restricts the kind of

factors that can affect the selection of a particular construction. Selection of a particular construction is primarily driven by a difference in the meaning of the event rather than by any overwhelming effect of context. This means that a meaning associated with a particular variant is intended by the speaker rather than resulting from the inferential processes of the hearer.

In what follows, a theoretical overview of CxG for the spray/load and dative alternations is summarised. Firstly, the definition of *construction* used here is made clear, identifying what aspects of meaning it can capture. Goldberg (1995) argues that this approach is preferred to a lexically driven account as it places less of a burden on the lexicon, and therefore supports the underlying theme of economy of language adopted here. Secondly, a description will be given of how a verb and construction integrate. Next, this will be applied to how the semantic interpretations of the structures relevant to this thesis are evoked. We will see that semantic interpretation of the dative construction and the locative variant construction are associated with the same meaning – a cause-motion meaning. This suggests that the structures for these constructions are the same. The association of a cause-to-receive meaning for the double-object construction, and the association of a causative meaning with an additionally specified *instrument* role for the *with*-variant construction will then be described. In (2.17), we see that the data is problematic, especially for the double-object construction and the *with*-variant construction. This is because CxG attempts to reconcile double-object construction exceptions by resort to polysemous interpretations of constructions. It will be shown that CxG relies on ad hoc semantic stipulations to capture exceptional cases. Moreover, it must resort to claims of metaphorical extension in order to account for abstract sentences that are not easily generalised to a generalised construction meaning. This is problematic firstly because it is not clear how to discern variable interpretations from a single construction without resort to stipulations. Moreover, by trying to capture all the data with stipulations makes this approach difficult to falsify. CxG also treats the *with*-variant construction as a ‘special case’ whose structure is differently derived from the general idea of constructions. This is a significant weakness for the CxG account. I show that Goldberg’s (1995) analysis of the *with*-variant construction is wrong both in the kind of structure that is proposed as well as the semantics of the construction. The data shows that the *with*-PP is not an adjunct, nor can it be associated with an *instrument* function, which suggests that the *with*-variant construction and the locative construction are much similar in meaning. Much of this analysis is not new, but serves to illustrate the weakness of this approach.³⁶

³⁶ Throughout this section, I refer to the roles that participants play in the event by their traditional semantic labels (e.g. *agent*, *theme*, *recipient*, and so on) for descriptive purposes. Recall that in this thesis these roles are viewed as inferences based on feature clusters rather than semantic primitives. However, in order to present

2.15.1. What is a Construction?

In CxG, whole constructions are the basic units of language that describe events which are distinguished from the event information which can be described by a verb. CxG is a usage-based account that views a construction as a free-standing entity stored in the lexicon alongside verbs and other meaningful units such as words and idioms. A construction is defined as a pairing of form with meaning such that some aspect of the form or some aspect of the meaning/use is not strictly predictable from the component parts or from other constructions already established to exist in the language (e.g. Goldberg, 1995; 1997; 2000). A construction is associated with a specific meaning which it shares with other constructs of the same type irrespective of the variety of verbs with which a construction can appear. This means for example, that the ascending structure of dative constructions are ‘Constructions’ with a generalised meaning irrespective of which verb or verb class they are paired with. Generalising over a structure in this way implies that there is a core-sense available to any sentence that is formed with a particular construction and a compatible verb. Particular argument structure patterns (such as the double-object construction) contribute directly to the meaning of a sentence. They have evolved to “reflect scenes basic to human experience” (Goldberg, 1992:4). The idea that constructions have as their basic sense semantics a set of scene-types that are based on a set of judgements that human beings are capable of making about the events that are going on around them stems from the functional linguistics of Charles Fillmore. A construction is “dedicated to a particular function in the creation of meaningful utterances in the language” (Fillmore, 1989: 18). The semantics of constructions revolve around ‘conceptual archetypes’ (Langacker, 1991) in which the skeletal form of a construction, independently of the main verb, designate patterns of human experience (Goldberg, 2000). This is formalised as the Scene Encoding Hypothesis:

(119) *Scene Encoding Hypothesis*: Constructions which correspond to basic sentence types encode as their central senses event types that are basic to human experience.

(Goldberg, 1995: 39)

An argument structure construction provides a distinct aspect of meaning that is not captured by the meaning of the verb. Sentence meaning is therefore a division of labour between the meaning of the construction and the meaning of the verb in a sentence. For example, for the sentence in (120) there

the CxG approach, it is necessary to refer to semantic labels as they form an essential part of a construction’s architecture and semantics in Construction Grammar.

is a distinction between the meaning contributed by the verb *kick* (to strike with the foot) and the meaning contributed by the construction that it is paired with. In (120a) the construction is claimed to contribute a cause-motion meaning: a ball is caused to move into the stadium. The verb contributes a richer semantics by contributing the manner in which the movement is initiated. The cause-motion interpretation of the construction involves manipulative causation and actual movement and is thus argued to be the central sense of the construction (Martinez, 2012). The sentence then has the reading of a ball being struck with the foot causing movement of the ball into the stadium (X causes Y to move toward Z). For the sentence in (120b), the construction is claimed to contribute a cause-to-receive meaning: Bob has in some way received the ball, whereas the verb contributes information about the manner in which the receiving is caused. The sentence then has the reading that the ball is struck with the foot so that it causes the ball to move to Bob so that he comes to receive it (X causes Y to receive Z). The verb *kick* intrinsically does not carry the entailment that any motion has been caused or that any transfer has been initiated as can be seen in the sentences in (120c) and (120d) respectively. Under the lexical approach (e.g. Pinker, 1989), each sentence in (120) is the result of individual verb entries, each with their own specific sense and argument structure.

(120) a. Pat kicked the ball (in)to the stadium.

b. Pat kicked Bob the football.

(Bencini and Goldberg, 2000: 641. Their 3 and 6.)

c. Pat kicked the wall.

d. Pat kicked the ball against the wall.

2.15.2. The fusion of verb and construction

One of the central arguments for meaningful constructions that exist independently from verbal meaning comes from a strategy to avoid implausible verb senses for cases when verbs appear in an unusual environment as in (121).

- (121) a. They laughed the poor guy out of the room.
b. Frank sneezed the tissue off the table.
c. Mary urged Bill into the house.

(Goldberg, 1995: 152. Her 1-3.)

These sentences cannot be explained compositionally because the verbs in (121) do not encode a cause-motion meaning. *Laugh* and *sneeze* are intransitive verbs that do not encode the causing of movement to an object, and *urge* is similar in meaning to *persuade* and so does not impart a physical force to move an object. What is claimed is that verbs like *laugh*, *sneeze*, and *urge* are associated with specific lexical-semantic information that allows them to integrate with the cause-motion construction. They have a semantic feature in their lexical entry that is compatible with cause-motion. *Laugh* and *sneeze* involve the forceful emission of air rather like the typically transitive *blow* and so they can be construed as being caused to an entity by an *agent*. The compatibility of *urge* is more abstract. *Urge* can be construed as having direct causation to a change of state by means of verbal persuasion. A cause-motion meaning is claimed to be linked via a metaphorical mapping of 'Change of State as Change of Location' (cf. Lakoff, 1993). The fact that an entity's state is changed by means of an agent urging/persuading this change provides the compatibility link for the metaphorical extension. If a link between a construction meaning and a verb meaning can be entailed, the verb and construction are licensed to fuse.

A verb in Goldberg's (1995) approach has a minimally specified lexical entry. A verb is associated with a concept, and may specify the number of arguments that are required to linguistically represent that concept. The verb's semantics specifies a list of roles that are accessed obligatorily and function as focal points within the scene, achieving a special degree of prominence (Langacker, 1987; Goldberg, 1995). For example the verb *sneeze* is associated with the participant role *sneezer* as illustrated in (122).

- (122) sneeze: <*sneezer*>

A verb is inserted into a construction if a semantic link can be entailed between verb and construction. In other words, the semantics of the verb is compatible with the meaning of the construction on some level. The verb *sneeze* in (121b) is compatible with the cause-motion construction because *sneezing* involves the forceful expulsion of air. The semantics of a *sneeze* event is therefore compatible with an inference of movement. *Sneeze* specifies the means by which the cause-motion relation is achieved, whereas the construction provides the rest of the semantics. As *sneeze* is listed as an intransitive argument it only profiles a *sneezee* role. This role is fused with the cause role of the cause-motion construction. The cause-motion construction contributes the *theme* and *goal* roles to the event's semantics. The fusion of *sneeze* and the cause-motion construction in (121b) yields the interpretation that *Mary caused the napkin to move off the table by the means sneezing*. With verbs that specify two participant roles (e.g. kick: <kicker, kickee>) as in (123), the cause-motion construction only contributes one argument (i.e. the *goal*). When a verb's semantics includes movement and lexically specifies three participant roles (e.g. put: <putter, puttee, put.place>) as in (124), the cause-motion meaning of the construction "is entirely redundant with the verb's meaning and the verb merely adds information to the event designated by the construction." (Goldberg, 1995: 51); essentially, the manner in which cause-motion is achieved.

(123) John kicked the ball (into the stadium).

(124) John put the vase on the table.

In order for a construction to be joined to a verb, the event type denoted by the verb and the construction should be relatable. A verb and a construction can only be 'fused' if they are compatible. In CxG, verbs are associated with specific semantic frames. Frame semantic information captures the various meanings associated with a lexical item such as those based on world and culturally-based knowledge, as well as experiences and beliefs. As such it does not rely heavily on objective truth-conditions, and allows more flexibility in the compatibility of verb and construction meaning. As such, *sneeze* is compatible with the cause-motion meaning if the roles contributed by the construction can be associated with participants in a possible state of affairs, where a sneeze can impart sufficient force to cause something to move. This means that the successful fusion of a verb and a construction is dependent on inferences based upon aspects of the context as well as the frame semantics. This is not made explicit in Goldberg's work, and this effect of context is not pursued. (125) provides a representation of the cause-motion construction. It consists of three distinct layers. The top line

contains the construction's meaning. It lists the constructional roles of the construction and specifies their relation to each other. The middle line contains open slots in which the verb's profiled roles can fuse to the roles of the construction. The bottom line lists the syntactic realisation³⁷ of the construction roles. Solid lines between the top and middle rows indicate that the construction role must be fused with an independently existing verb role. Dotted lines represent constructional roles that do not need to have a profiled lexical role to fuse with. The construction independently contributes this role to the sentence.

(125) *The Cause-motion Construction Array*

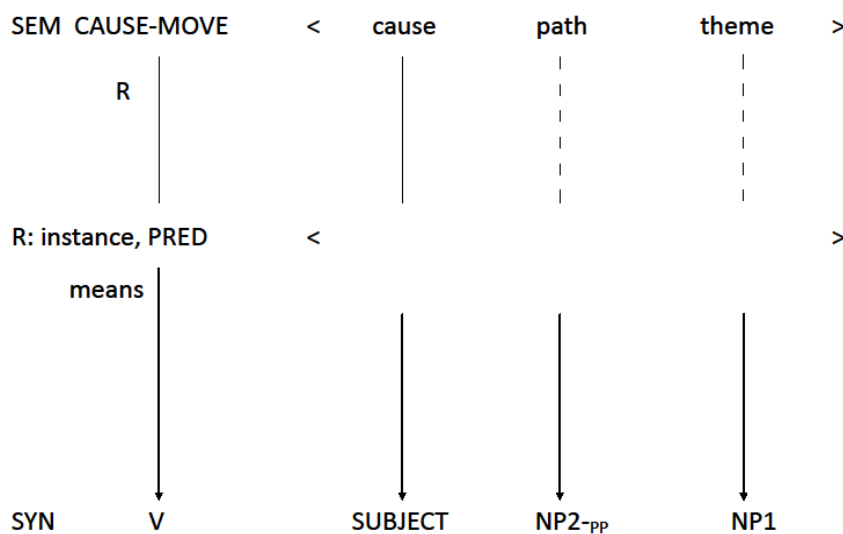

(Goldberg, 1995: 163)

As it stands, (125) suggests that any verb can be fused with a construction if it has a profiled role that is compatible with the *cause* role of the construction. This is obviously not the case as can be seen in (126).

³⁷ I have maintained my classification of objects as NP1 and NP2. In (125) NP1 is marked as NP2-PP as it requires a prepositional phrase in this construction. Goldberg (1995) labels this argument as *Oblique*.

- (126) a) *Sam scratched himself out of the room.
b) *Sam smiled a letter to Jane.

In order to limit the application of incompatible verbs and constructions and to ensure that only semantically compatible roles are fused, Goldberg (1995) proposes the Semantic Coherence Principle given in (127).

(127) *The Semantic Coherence Principle*

Only roles that are semantically compatible can be fused. Two roles r_1 and r_2 are semantically compatible if either r_1 can be construed as an instance of r_2 or r_2 can be construed as an instance of r_1 .

For example the *sneezer* in the sneeze event in (121b) may be fused with the agent of the cause-motion construction as the *sneezer* can be construed as a direct cause of the sneezing event which means it can be matched to the *cause* role of the construction. The *sneezer* can be thought of as causing the movement by a particular manner – *sneezing*. A verb like *scratch* in (126a) may also profile a role that is compatible with the *cause* role of the construction, however the meaning of *scratch* is not construable as a manner in which motion is caused. In the case of verbs that list three participants, there must be a one-to-one compatible mapping of the verb's roles to those of the construction. This is determined by the Correspondence Principle given in (128).

(128) The Correspondence Principle

Each participant role that is lexically profiled and expressed must be fused with a profiled argument role of the construction.

(Goldberg, 1995: 50)

According to this principle, a role is only lexically profiled if it is obligatorily expressed, and only argument roles which are profiled by the construction are expressed as direct grammatical relations. Without such a restriction, a profiled verb role could be expressed by the insertion of additional structure which is not part of the construction. Conversely, the construction could have a slot that requires obligatory fusion with a verb role but still remains ‘unfused’, in which case a mapping of verb roles and construction roles becomes unbounded and purely stipulative rather than principled. However, Goldberg (2006: 40) explicitly states that the Correspondence Principle is a default principle that “can be overridden by particular constructions that specify that a particular argument be deemphasised and expressed by an oblique or not at all.” This is just what Goldberg (1995) proposes for the *with*-variant construction. Because of this stipulation a separate construction does not need to be posited for constructions that optionally express an argument such as the passive sentence in (129).

(129) a. The cat was chased (by the dog).

It is the Semantic Coherence Principle and the Correspondence Principle that regulate the fusion of verbs and constructions. The latter principle ensures that there is a one-to-one mapping of obligatorily expressed verb roles with profiled roles of a construction. It also does not allow any phonologically null elements left in the structure (Goldberg, 2003). The Coherence Principle does not prevent the expression of roles in the construction when there is not an available verb role to fuse with. The Semantic Coherence Principle ensures that only a semantically compatible fusion occurs between verb roles and the roles of the construction. With this essential background in place, we can now turn to how this constrains the formation of the constructions relevant to this thesis. The sub-section starts with the cause-motion construction.

2.16. Constructing constructions

2.16.1. Constructing the cause-motion construction

A caused motion meaning for the dative construction (130a) and a caused transfer meaning for a double-object construction (130b) have been argued for by many linguists (e.g. Anderson, 1971; Borkin, 1974; Fillmore, 1968; Partee, 1965; Wierzbicka, 1988; Pinker, 1989; Gropen et al., 1991; Goldberg, 1995; Harley, 1996; Krifka, 2001; a.o.).

(130) a. Sarah sent the letter to John.

(X causes Y to go toward Z)

b. Sarah sent John the letter.

(X causes Z to receive Y)

In CxG, the licensing of a construction with a verb is based on the semantics of the verb and its compatibility with the semantics of the construction. For the cause-motion construction, the verb's semantics must be construable with motion. The direction of the *theme* argument must be presumed to be determined by the action of the subject. This means that no contrary tendency is allowed. Recall that the verb *sneeze* could combine with the cause-motion construction because it is compatible with a motion inference caused by the act of forcibly expelling air. In the same way that *sneeze* combines with the cause-motion construction, a three role verb like *send* must have roles that are compatible with the roles specified in the cause-motion construction. In the case of *sneeze*, only one role is specified by the verb's semantics, and it is only this role that combines with a single role of the construction. The other roles in a sentence like (121b) are expressed directly by the construction without any fusion taking place. However, when the verb obligatorily has three participants in its frame semantics, each of these roles must be construable with a role of the construction. A verb like *send* is a three-argument verb. The event denoted by *send* has three participants: a *sender*, a *send.place*, and a *send.thing*. In CxG, there is nothing in the verb's semantics that specifies a path that the *send.thing* can move along, it only indicates a location – the *send.place*. It is the construction that contributes the *path*. Recall that the cause-motion construction contains the participant roles: *cause*, *theme*, and *path*. Only by mapping one of the verb's participants to the construction's *path* role can a path reading with *send* be licensed; the path reading only exists as a feature of the construction. As we saw with the verb *sneeze*, the initiator of the action is associated with the *cause* role of the construction. But unlike *sneeze*, *send* specifies two additional roles which need to be matched with the other roles of the construction – the location of the sending and the thing being sent. The *send.place* role of the verb is fused with the *path* role of the construction as a location can be construed as existing on the end point of a path. The *send.thing* fuses with the *theme* role of the construction as it can be construed as being directly affected by the action. Once this fusion has taken

place, the pairing can then be mapped onto the grammatical categories of the cause-motion construction. This process is illustrated in (131) for the sentence *Sam sent the keys to John*.

(131) a. send: <sender (*Sam*), *send.place* (*John*), *send.thing* (*the keys*)>

b.

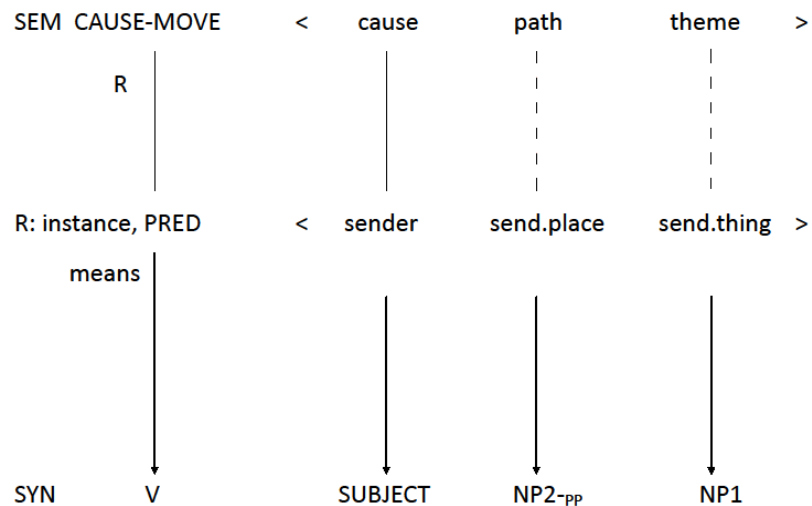

c. Sam sent the keys to John.

The participant *John* has the role of the *send.place* – the locational endpoint of the action. This role is fused with the *path* role of the construction which yields the interpretation that this locational endpoint has not been reached; it only means that motion has been caused with the intention of it being reached.

2.16.1.1. Semantic compatibility and the cause-motion construction

Goldberg (1995: 170) states that a verb is only licensed to fuse with the cause-motion construction, if motion can be entailed from the verb semantics. This prevents the over generation of cause-motion constructions. This goes some way to account for why many verbs three-place verbs only appear with a double-object construction. In (132), the acts denoted by the verb do not entail that the lexical role fused with the *theme* actually moves, and so they are incompatible with the cause-motion

construction. This constraint also restricts the over productivity of the construction with the intransitive and transitive verbs in (133) that cannot be construed as involving motion.

- (132) a. *Bill spared the embarrassment to John.
b. *Bill appointed the leader to Bill.
c. *John branded a liar to Bill.

- (133) a. *John saw Bill to the garden.³⁸
b. *John ate the sandwich to the garden.
c. *John picked the apples into the basket.
d. *John stopped the bus to the garage.

However, this rule does not account for the unacceptability of a sentence like (134). In (134), the mail bag is an instrument and so can be seen as being at least partly causal in the event of sending the letter (recall that in the Theta System, the feature cluster usually inferred as an instrument is marked with the feature /+c).

- (134) *The mail bag sent the letter to John.

In order to account for the data that are not directly captured by the semantic fusion of verb and construction roles, Goldberg (1995) stipulates a number of additional semantic constraints and conditions for the compatibility of a verb and the cause-motion construction. The first is a constraint, which applies to the *cause* role of the cause-motion construction. Goldberg states that this role can

³⁸ See in the sense of *see off* or *accompany to* is a three-place predicate. However, we abstract away from this dialectal variant.

only be an *agent* or *natural force*, not an *instrument* (Goldberg, 1995: 165). In (131), *Sam* is the agent of the action so the condition is met. However, in (134) *the mail bag* can only be instrumental to the action so fusion with the agent role is not licensed.

A second constraint is that the *theme* argument cannot make a cognitive decision in relation to the movement. "No cognitive decision can mediate between the causing event and the entailed motion" (Goldberg, 1995: 167). This also allows *send* to be fused with the cause-motion construction in (130) because the final decision about whether movement takes place does not lie with the participant fused with the *theme* role. This is also why verbs like *convince*, *persuade*, and *encourage* do not appear with the cause-motion construction as they are reliant on the *theme* participant to determine whether the action is successful, whereas verbs like *entice*, *coax*, *frighten*, and *lure* do not rely on the contribution of the *theme* participant. This is shown in (135).

- (135) a. *Sam convinced/ persuaded/ encouraged John to the pub.
b. Sam enticed/coaxed/frightened/lured John to the pub.

A third stipulation is a condition which says that if the action denoted by the verb implies an effect other than motion, then a path of motion cannot be specified. In (136) the verb *shoot* can be interpreted in such a way that it does not involve movement. If *the bullet* penetrates *Sam*, then *Sam* is affected in a way that does not involve motion, and so motion cannot be specified.

136. *Pat shot Sam across the room (on the interpretation that Pat shot Sam and the bullet forced him across the room).

(Goldberg, 1995: 170. Her 98.)

It is also the case that if caused movement in the event was unintentional, then the cause-motion meaning is unavailable. In (137), the conventional sense of *slice* implies incidental movement of the

argument inferred to be the *theme*. Whereas in (138) movement is unintentional and so the construction is not licensed.

(137) The butcher sliced the salami onto the wax paper.

(138) *Sam unintentionally broke eggs onto the floor.

(Goldberg, 1995: 171. Her 99 and 103 respectively.)

2.16.1.2. Spray/load verbs and the cause-motion construction

Goldberg (1995; 2002) also views the locative variant construction of the spray/load alternation as an example of a verb + cause-motion construction³⁹. Verbs that can appear in this variant have participant roles that are compatible with those of the construction. This means that the semantics of these verbs are compatible with the 'X causes Y to move to Z' semantics of the construction. The difference between the dative construction and the locative variant construction is that in the latter, the verb additionally encodes a richer semantics about the manner in which the action is achieved⁴⁰. This is claimed to be due to spray/load verbs having a richer semantics than dative verbs. Importantly, this means that both the dative and locative variant constructions must share the same syntax; each has a direct object (NP1) and an object introduced by a prepositional phrase (NP2). The semantics are also closely related. The subjects for both the dative and locative variant constructions serve to cause the motion of the NP1 argument along a conceptual path whose endpoint is NP2. This means that the process of fusing the verb's roles with that of the cause-motion construction is the same for the dative construction and the locative variant construction, as illustrated in (139) for *load* and in (140) for *spray*. In (139), the *loader* participant fuses with the *cause* role of the construction, the verb's

³⁹ It should be noted that following Pinker (1989), Goldberg (1995) distinguishes between *load* verbs and *spray* verbs in the spray/load class based on a fine-grained difference in their respective semantics. However, in Goldberg's (1995) analysis the behaviour of the spray/load verbs used in this thesis are the same as they both have three profiled roles, and the optional omission of the construction's *theme* argument is constrained by contextual givenness. As such any semantic distinction is irrelevant here.

⁴⁰ What is interesting here is that this proposal implies that the verb affects the form of the preposition. It is the type of action denoted by the verb that determines the manner that the path is traversed. It is not the participants in the event which determines the kind of preposition that it may appear with. This suggests that the thematic structure is not relevant in determining the presence of a preposition; rather it is part of the projection of the verb's semantics.

loaded.theme fuses with the *theme* role of the construction, and the *container* role fuses with the *path* role of the construction.

(139) a. load: < loader, container, loaded theme >

(Goldberg, 2002: 344)

b.

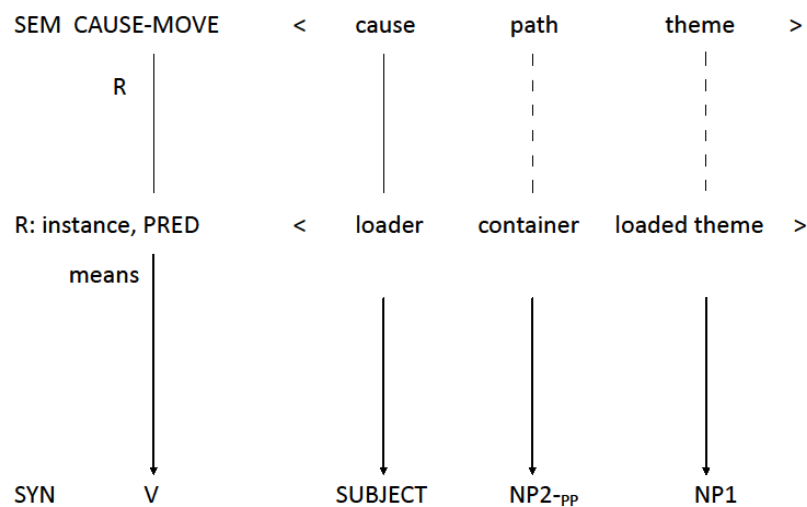

c. Sam loaded the hay onto the truck.

As can be seen in (140), *spray* profiles three roles: a *sprayer*, a *target*, and a *liquid*. The *sprayer* can be construed as a kind of *cause*, the *target* can be construed as a type of *goal-path*, and the *liquid* can be construed as a *theme*. This allows *spray* to fuse with the cause-motion construction.

(140) a. spray: < sprayer, target, liquid >

b.

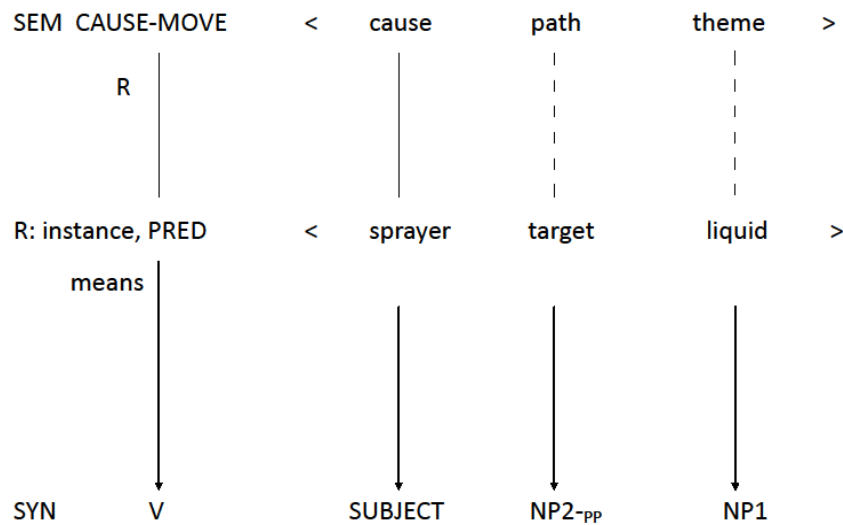

c) Sam sprayed paint onto the wall.

The idea that both the locative variant construction of spray and load verbs and the dative construction from the dative alternation are instances of the same construction is the same as saying that they have the same structure. This matches the proposal in this thesis, namely that these variants have the same syntax, although CxG states that there is no compositional syntax so this is where the similarity between these analyses ends. The factors that are said to motivate the preference for a construction differ considerably in both accounts. Goldberg (1995) also makes no direct reference to hierarchical structure. Moreover, Goldberg (1995) proposes a distinct analysis for the structure of the double-object construction and the *with*-variant construction. The discussion now turns to these constructions.

2.16.2. Constructing the cause-to-receive construction

The double-object construction is Goldberg's (1995) cause-to-receive construction. The cause-to-receive construction is claimed to have the meaning X causes Z to receive Y (Goldberg: 1995: 106). The construction array for the cause-to-receive construction is given in (141).

(141)

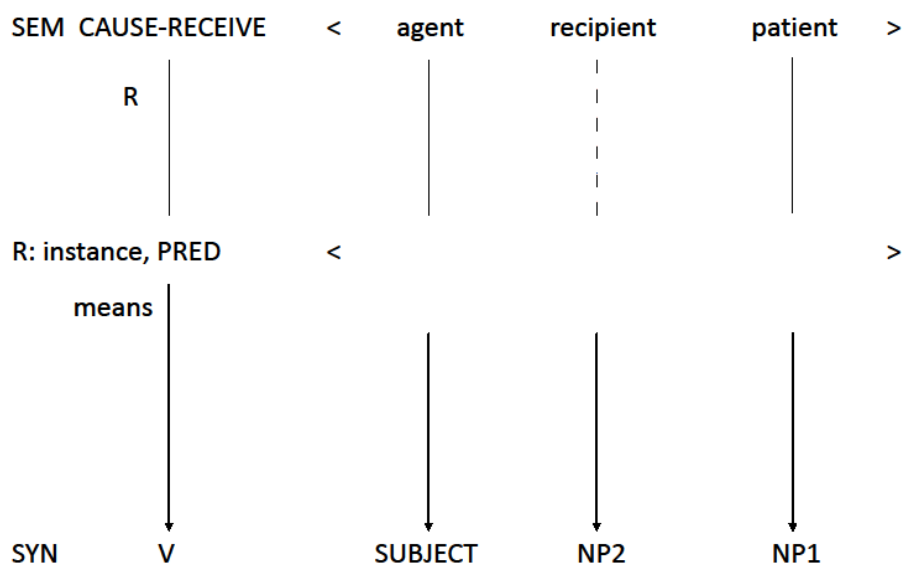

The participant roles of this construction differ from those of the cause-motion construction. The cause-to-receive construction encodes an *agent*, a *patient*, and a *receiver*. As can be seen in the array, the *receiver* role is not obligatorily fused with a profiled verb role but can be contributed directly by the construction. The construction's *agent* and *patient* roles must be fused with independently existing roles profiled by the verb as can be seen by the solid lines in between the top and middle rows in (141). The *recipient* role may be contributed by the construction as indicated by the broken line between the top and middle role. This means that an intransitive verb like *sneeze* is incompatible with the cause-to-receive construction as it only profiles a single participant role – **Sam sneezed Bill a pen*. Goldberg (1995) notes that the double-object construction is unique as it allows two non-predicative noun phrases to occur directly after the verb. It is the only construction in which a *recipient* role is linked to an NP2 grammatical function that is not introduced by a preposition⁴¹. Goldberg (1995; 2002) claims that all instances of a double-object construction require closely related semantics. The central sense of the construction is argued to involve an event of transfer between “a volitional agent and a willing recipient.” (Goldberg, 1995: 141). Evidence for this constructional meaning comes from sentences like (142).

⁴¹ This contradicts the earlier suggestion that it is the verb that influences prepositional material. In which case, the cause-to-receive construction is not unique as Goldberg (1995) argues; the only structural contribution it makes is the linear order of NPs.

(142) Sally baked her sister a cake.

(Goldberg, 1995: 141)

Goldberg (1995) claims that the only possible interpretation of (142) is that Sally baked a cake with the intention of giving it to her sister. If the transfer meaning is attributed to the verb then it is claimed that the verb *bake* must mean something akin to “X intends to cause Y to receive Z by baking”. But this is not the general sense of the verb *bake* when it appears with other constructions. If the notion of *giving* was included in the verb’s semantics when it appears in the double-object construction, then multiple senses would be required for each kind of construction with which *bake* can appear that do not entail the notion of ‘giving’. In the double-object construction a *recipient* role is profiled. Goldberg (1995) notes that the notion of *giving* involves a willing recipient. It is distinguished from a path type role as she claims that this participant is obligatorily animate. This has been claimed in other work (e.g. Partee, 1965; Green, 1974). If a *goal* is animate then it must be a *recipient* (Goldberg, 1995: 142). This is why in (143a’) *London* is only felicitous when it metonymically refers to a person or organisation. In (143b’) a *car* cannot be construed as being an animate entity and hence unable to be recipient.

(143) a. Ann sent a package to London.

a’. Ann sent London a package.

(Krifka, 2003: 2. His 7.)

b. Ann brought the package to the car.

b’. *Ann brought the car the package.

The fusion of a verb with the cause-to-receive construction proceeds as follows. A dative verb like *hand* has the entry in (144). By way of the Correspondence Principle, all of the verbs’ three lexically profiled roles are fused with the constructions’ roles. By way of the Semantic Coherence Principle, the verb’s *hander* role is compatible with the *agent* and so fuses with this constructional role, the *handee*

is animate and so the condition on animacy is met and therefore it can fuse with the *recipient*, and the *handed* participant is compatible with the theme.

(144) a. hand: <hander, handee, handed > (Goldberg, 1995:51)

b.

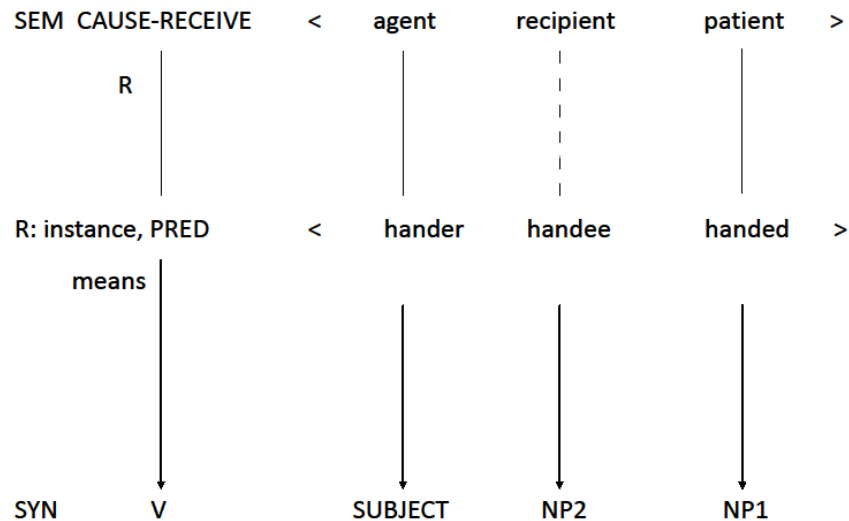

c. Sam handed Laura the keys.

As with the cause-motion construction the cause-to-recipient construction is subject to semantic constraints to prevent over productivity with incompatible verbs. It is to these constraints that we now turn.

2.16.2.1. Semantic compatibility and the cause-to-recipient construction

As noted above, the referent of the recipient designated as the NP2 argument must be animate. However, this constraint is too strong and does not account for the examples in (145), where the NP2 argument is not an animate entity. Goldberg (1995) claims that the NP2 arguments in (145) are animate by way of a metaphorical extension of ‘transfer of ownership as physical transfer’. Ownership is construed as “an entity which can be ‘taken away’ or ‘given’ and thus transferred by physical movement.” (Gerwin, 2014: 31). Ownership of something is a feature usually associated with animate

entities, therefore the NP2 arguments in (145) can be inferred to be animate by metaphorical extension, and so the construction is licensed.

- (145) a. The paint job gave the car a higher sale price.
b. The Tabasco sauce gave the baked beans some flavour.
c. The music lent the party a festive air.

(Goldberg, 1995:146. Her 14-16.)

Another semantic constraint is based on the observation that the verb role fused with the construction's *agent* role must be seen as volitionally causing the action denoted by the verb. This must be extended so that not only is the action performed purposefully, but the transfer must be intended. This presumes the animacy of this role and determines the construction role as an *agent* rather than only a *cause*. In (146) Joe is understood to intend the giving action. (146) is infelicitous if the transfer is unintended. "It cannot be the case that Joe painted the picture for someone else and later happened to give it to Sally." (Goldberg, 1995: 143).

- (146) a. Joe gave Sally a picture.

(Goldberg, 1995: 143. Her 3.)

There is an additional semantic constraint for the cause-to-recipient construction which has to do with the willingness of the recipient role. This constraint is needed to account for examples such as (147) from Green (1974) cited by Goldberg (1995: 146). The sentence is only acceptable on a construal that Joe likes burnt rice or that Sally is only capable of burning rice.

- (147) Sally burned Joe some rice.

In all cases in which the NP2 argument is required to accept the transferred object in order for the transfer to be successful, this argument is assumed to be a willing recipient. There are exceptions where the recipient is unlikely to be *willing* such as those in (148). The willingness of the participant is irrelevant to the successful transfer in (148a), and in (148b) and (148c) transfer is implied by the metaphorical extension ‘change of state as change of location’ (Lakoff, 1993).

- (148) a. Bill gave Chris a speeding ticket.
b. Bill gave Chris a headache.
c. Bill gave Chris a kick.

(Goldberg, 1995: 147. Her 22-24.)

Goldberg (1995) notes that *recipient* is a more accurate label than Pinker’s (1989) (*prospective*) *possessor*. This is because many sentences involving transfer do not imply that the *recipient* actually physically possesses the *theme* as illustrated in (149).

- (149) Joe gave Mary an insult.

The sentence in (149) does not suggest that Mary possesses an insult, only that she has received one. Goldberg (1995) claims that a possession reading from the cause-to-receive construction is regularly implied because what is received is normally subsequently possessed. The cause-to-receive construction is generally associated with a scene of transfer, so describing the NP2 argument as a *recipient* rather than a *possessor* better captures the character of the semantics. In CxG, the semantics of the double-object construction is distinct from the semantics of the *with-variant* construction as I show in the following section.

2.16.3. The change-of-state-plus-*with*-adjunct construction

2.16.3.1. Semantic compatibility and the change-of-state construction

The *with*-variant construction has different properties from what Goldberg (1995) claims to be a typical construction. The *with*-variant construction is claimed to be associated with a change-of-state meaning. It is generally accepted that the *with*-variant construction has a subtle difference in meaning from the locative variant in the spray/load alternation. The former has been attributed to some kind of ‘holistic’ effect described by Anderson (1971: 389) as a matter of whether the whole of something is affected by the action described by the sentence, or whether only part of it is affected. (150b) is thus interpreted to mean that the truck has been entirely filled with the hay in the loading event, but it is underspecified whether the hay has been entirely used up or not. This is in contrast to (150a) in which all of the hay is interpreted as being completely moved to the truck’s location but it is underspecified whether the truck is entirely filled with hay or not (cf. Beavers, 2004).

- (150) a. Sam loaded hay onto the truck.
b. Sam loaded the truck with the hay.

Goldberg (1995) following Pinker (1989) treats the *with*-variant construction as a constructional variant of a causative construction by combining the causative construction with an independent construction headed by *with*. This is claimed to account for the ‘affectedness’ of the theme role. This is an unusual construction for CxG because the *with*-PP is considered to be an adjunct and not part of the causative construction. A causative construction profiles two roles: a *cause* and a *patient*. The *patient* is taken to be entirely affected by the *agent*’s action as in (151).

- (151) a. hit: < hitter, hittee >
Sam_{CAUSE} hit Bill_{PATIENT}.
b. Lick: < licker, lickee >
Sam_{CAUSE} licked the stamp_{PATIENT}

On this view, the *with*-variant construction involves the addition of a phrasal adjunct (*with*-PP) tagged onto the causative construction. It is claimed that this element has an *instrument* interpretation in the event. It is viewed as being closely related to other *with* phrases associated with an *instrument* interpretation as in (152).

- (152) a. Sam hit Bill with a stick.
b. Sam loaded the wagon with hay.

As with other instruments, the role linked to the *with*-PP is understood to function as an intermediary to the causal chain of the event between *agent* and *patient* (Goldberg, 2002). The entity corresponding to this role is characterised by it being manipulated by the *agent* in order to effect the change of state of the *patient*. There is a semantic distinction between the two *instrument* entities in (152a) and (152b). In the former, this entity is an independent tool which makes direct contact with the *patient*; changing its state, and in the latter, the entity is something that is moved onto the patient; changing its state. There are cases where this role has both interpretations as in (153).

- (153) Pat wrapped the present with tin foil.

(Goldberg, 2002: 340. Her 51h.)

Examples like (153) provide the basis for the claim that both interpretations can be generalised under the label *intermediary instrument* as they both serve an intermediary role between *agent* and *patient*.⁴² The fine distinction between the kinds of *instruments* involved follows from semantic differences in the verbs involved, and so “do not necessitate treating the *with*-phrases as instances of unrelated constructions.” (Goldberg, 2002: 341).

⁴² This appeals to the idea of grammatical chains (Heine, 1992) where one instance of *with* may be related to a second instance, and that second instance with a third instance of *with*, but this does not entail that the first and third instances are of the same type.

Syntactically the *with*-phrase is classified as an adjunct which is a classification generally attributed to other *instrument* PPs (see also Levin and Rappaport, 1988; Jackendoff, 1990). Support for this analysis comes from the optional realisation of the *with*-phrase with many spray/load verbs such as *spray* and *load* in (154). Optionality is a characteristic of adjuncts.

- (154) a. Pat loaded the wagon (with the hay)
- b. Pat sprayed the wall (with the paint).
- c. Pat covered the baby (with a blanket).
- d. Pat stacked the shelves (with books).

Goldberg and Ackerman (2001) argue that the function of the optional phrase stems from the Gricean maxim of Quantity (Grice, 1975) which states (i) to make your contribution as informative as is necessary, and (ii) do not make your contribution more informative than required. What this means for the *with*-variant construction is that the adjunct is expressed in a context where additional information is needed for effective communication of the causative event. Goldberg (1995) claims that this role can be unexpressed only when it is contextually licensed by it being known to both speaker and hearer what affected the *patient*. Goldberg (1995) argues that this type of argument is still lexically profiled despite the fact that it can be optionally expressed. This is in conflict with the Correspondence Principle stated in (128) because a profiled lexical role is not fused with a role profiled by the construction; an additional grammatical structure is added to the construction. In order to accommodate this, Goldberg stipulates that if a verb has three profiled roles, then one of them may be fused with a non-profiled role of the construction⁴³.

Goldberg (1995) supplies no depiction of the change-of-state-plus-*with*-adjunct construction and its verb fusion. As such, the array for the change-of-state-plus-*with*-adjunct construction with the verb *load* is predicted to look like (155). In (155), fusion of lexical roles with the *agent* and *patient* construction roles is obligatory as would be expected from a causative construction. The *instrument* role and the *loaded.theme* also fuse obligatorily but they are only optionally mapped to a grammatical

⁴³ It should be noted that this condition is only available for a small subset of spray/load and dative verbs.

function distinct from the causative construction—the *with*-PP adjunct. The addition of the instrument participant to the causative construction is indicated by parentheses.

(155) a. load: < loader, container, loaded.theme >

b.

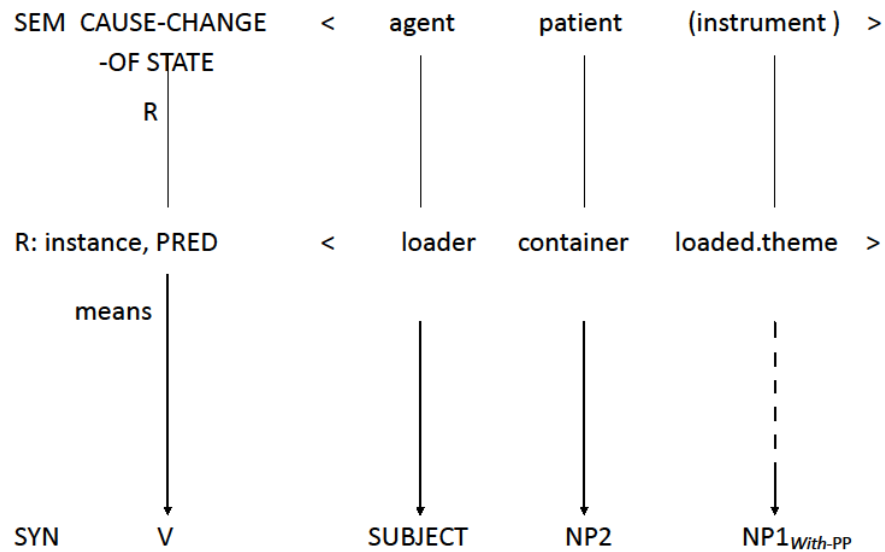

c. Sam loaded the truck (with the hay).

For the cause-change-of-state-plus-*with*-adjunct construction, Goldberg (1995) provides no additional semantic constraints to stop the over application of this construction. This means that as long as the action denoted by the verb can be construed as able to cause a change of state, and that two of the lexically profiled roles are compatible with the roles of the causative construction, then an acceptable sentence can be generated. Nothing limits the application of additional structure.

In this section an overview of the Construction Grammar approach of Goldberg (1995) was given. Each variant of the spray/load and dative alternation are argued to have distinct structures that are not derived from one another. Neither construction is a compositional structure but rather a free standing construct that is stored in the lexicon. Each variant of the spray/load and dative alternation is a construction that is associated with a distinct meaning. The dative and locative variant constructions are claimed to share a cause-motion meaning, the double-object construction is associated with a cause-to-receive meaning, and the *with*-variant construction is associated with a change-of-state

meaning, with an optionally specified instrument. In this approach, a sentence is an independent pairing of a construction with a single verbal entry. This approach claims that both the verb and the construction contribute meaning to the sentence. The construction describes the kind of event and the verb expresses the manner of the action in which the event is carried out. It was shown that a benefit of this approach is that implausible verb senses are avoided. This is because a sentence is constructed by fusing a single verb entry with a particular construction that is associated with a generalised semantics. It was shown that in order to stop over application of a construction, the fusion of verbs and constructions are regulated by the Semantic Coherence Principle and the Correspondence Principle. In addition, specific semantic stipulations are proposed to constrain the over application of a construction. Each role of the construction (which may or may not have been fused to a profiled lexical role) is mapped to a grammatical function, and the order of the grammatical category is specified by the construction. This approach makes no reference to hierarchical structure and makes no claim as to why a construction has a particular word order. This is because the structure-meaning relation is arbitrary.

In the following section, we look more closely at some problems with this approach as regards the spray-load alternations. First it is demonstrated that the account of the fusion between verb and construction roles is problematic. Next, it will be seen that the proposed compatibility between the verb and the construction is not so straightforward. I then focus on the *with*-variant construction, and illustrate that the CxG analysis of the *with*-PP as an instrumental adjunct is misplaced. This phrase does not behave like other instrumentals, nor does it behave like other adjuncts.

2.17. Problems with the Construction Grammar approach

2.17.1. Problems with the fusion of verb and construction roles

One of the fundamental claims of the CxG approach is that two kinds of participant roles exist. One kind is profiled by the verb's lexical entry, and the other is profiled in the construction. They are "semantically constrained relational slots in the dynamic scene associated with either the construction or the verb." (Goldberg, 1995: 49). The constructional roles are of a more general type such as *agent* or *patient*, whereas the verb's roles are frame-specific. In order to license the fusion of a construction and a verb, the semantics of the verb must be compatible with the semantics of the construction. Goldberg (1995) claims that compatibility can be satisfied on a number of different levels. Firstly, a construction is licensed if the profiled roles of the verb are semantically compatible with the profiled roles of the construction. Recall that this is determined by the Semantic Coherence Principle:

“The Semantic Coherence Principle ensures that the participant role of the verb and the argument of the construction are semantically compatible. In particular, the more specific role of the verb must be construable as an instance of the more general argument role.” (Goldberg, 2006: 40).

If we take the verb *kick*, the entry of the verb profiles a *kicker* and a *kickee* which are specific instances of participants that are unique to the *kick* semantic frame. As these roles are profiled by the verb they must be obligatorily fused with an argument of a construction. *Kick* can appear with a number of different constructions which are not exhaustively presented in (156).

- (156) a. Pat kicked the ball (in)to the stadium. (cause-motion construction)
b. Pat kicked Bob the football. (cause-to-receive construction)
c. Pat kicked the wall. (causative construction)

In order for the *kicker* argument *Pat* to be fused with each of the constructions in (156), it must be construable with the construction role that is ultimately mapped to the subject function in each of the constructions. Recall that this profiled role is a *cause* for both the causative and the cause-motion constructions. In the cause-to-receive construction this role is specifically an agent. Goldberg (1995) also stipulates that in the cause-motion construction, the cause can only be construed as a natural force or an agent, and not an instrument. Following our analysis of the Theta System from (2.6), the *kicker* argument can therefore only be assigned the underspecified [+c] cluster, as in one case it is inferred to be an *agent* and another it is inferred to be a *cause*. It cannot be assigned the [+c +m] cluster as it not solely an *agent*, it can also be inferred as a *cause*. It also cannot have the [+c –m] cluster because this is associated with an inferred *instrument*. The only option available is therefore [+c]. However, an *instrument* inference is not blocked by the [+c] cluster⁴⁴. If the *agent/cause-but-not-instrument* slot is correct in the cause-motion construction then there should be no occurrences of the cause-motion construction in which this slot is associated with an *instrument* reading. On the

⁴⁴ This is compatible with the view in Van Valin and Wilkins (1996) and Ramchand (2003), who claim that the causal role in subject position is underspecified. In this work the relevant notion is that of *effector* or an *abstract initiator/causer*.

other hand, the Theta System does not block an *instrument* inference of an argument assigned a [+c] cluster.⁴⁵ An *instrument* reading is possible, as can be seen in (157).

- (157) a. The crane loaded the boxes onto the truck.
b. This fork can scoop all the spaghetti into the bowl.
c. The map led the pirate to the treasure.

In each of the examples in (157), the argument in subject position can be argued as not directly causing the action of the verb. In each case, the argument in subject position can be viewed as having a facilitating role in the event, which is a feature of instruments. In (157a) the crane is not an autonomous entity, it must be operated by an external force which makes it a medium by which the action of the verb is carried out. In (157b) *the fork* is the medium that is used to facilitate the scooping; it cannot cause the action unless an agent applies the appropriate force to it. *The map* in (157c) is the tool that facilitates the event which can only be accomplished if another entity – *the pirate* – uses it appropriately. Syntactically, the subject referents in (157) also behave like typical *instruments* because they readily appear as *with*-PP adjuncts which are typical of *instruments* but not of *agents* or *causes* as illustrated in (158). This suggests that Goldberg's constraint does not hold.

- (158) a. The boxes were loaded onto the truck by Pat (with a crane/*with Sam).
b. All the spaghetti was scooped into the bowl by Pat (with a fork/ *with Sam).
c. The pirate was led to the treasure by Pat (with a map/*with Sam).

Goldberg's (1995) generalisation that the subject position in a cause-to-recipient construction requires an animate agent entity also appears to be wrong. This entity does need to be an instigator of the action described by the verb, but its animacy is not a determining factor for licensing the fusion,

⁴⁵ Although see Alexiadou and Schäfer (2006), which claims that *instrument* subjects are in fact instances of either a *cause* or an *agent* participant.

although an inference of animacy is possible. In the Thematic Hierarchy, the verb must consistently profile a [+c+m] cluster if it is to be consistently construed as animate. It must have a positive cause feature [+c] and if it is animate, its mental state must have the positive value /+m. An underspecified [+c] cluster does not block the inference that this argument is inanimate. As can be seen in (159) this constraint also does not hold.

- (159) a. The falling branch gave Pat a nasty bump on the head.
b. The medicine brought John some relief.
c. The syntax lecture taught me something.

In each of the cases in (159), the argument in subject positions are not inherently animate and so cannot be considered *agents* in the traditional sense as there is no mental state that can be attributed to them. However, these entities are at least in part causal to their respective events. The falling branch (159a) can be construed as an indirect cause of the bump-giving event; the direct causal force being gravity. John's relief in (159b) is brought about by the inherent properties of the medicine rather than the medicine applying a causal force. The syntax lecture in (159c) can only be construed as an instrument. The syntax lecture is the medium in which a lecturer teaches rather than the lecture itself that causes the learning. This means that the *agent* role in Goldberg's (1995) cause-to-recipient construction array can only be linked to a [+c] cluster because a [+m] and [-m] inference is available for this argument as it can be inferred to be an *agent*, a *cause*, or an *instrument*, and this inference may have an effect on the kind on the interpretation of the event. As can be seen in (160), the kind of causal role is not constrained. In (160a), the relief is not directly caused by the subject, whereas in (160b) relief is only achieved if the subject directly causes it, for example, by giving John medicine.

- (160) a. The medicine brought John some relief.
b. The nurse brought John some relief.

As I have shown, the semantic restriction stipulated over the kind of participant that can be mapped to the *cause* role in the cause-motion and cause-to-receive constructions is unfounded. This brings into question the efficacy of Goldberg's (1995) semantic constraints on the fusion between verb roles and construction roles. Further evidence that impacts on this analysis comes from the purported semantic constraint on the *recipient* of the cause-to-receive construction. Recall that Goldberg (1995) suggested that a *recipient* argument must have a construal that it can willingly take ownership of the thing being given. *Willingness* is a misleading categorisation. It implies that this participant must be attributed with an awareness of the event in order to be attributed with a willingness to receive. As we see in (161), the willingness of the proposed recipient *Chris* is not likely, as I have yet to encounter someone who is willing to receive a speeding ticket. However, the ability to take ownership is something that can be attributed to *Chris*. Moreover, the ability to take ownership of something can account for the difference in acceptability of (161).

- (161)
- a. Bill gave Chris/??the baby a speeding ticket.
 - b. The judge handed Chris/??the donkey a summons.
 - c. The mosquito gave Chris/ ??the sausage malaria.

Moreover, in (162) it appears to be the blocking semantics of the action by the subject rather than any notion of unwillingness of the recipient that makes these sentences infelicitous.

- (162)
- a. *Bill prevented Sam a million pounds.
 - b. *Bill barred Sam a doctorate.
 - c. * Bill intercepted Sam malaria.
 - d. * Bill stonewalled Sam his thesis.
 - e. *Bill clogged the dam water.

Based on this evidence, it appears that the semantic constraints that govern the fusion of verb and construction roles in Goldberg (1995) are not generalisations, but unsupported stipulations based on the occurrence of specific verbs involved in the cause-motion and cause-to-receive constructions. For example, the verb *send* does not readily appear with an inanimate cause as shown in (134) repeated below in (163a). Other verbs of sending (Levin, 1993) are more flexible, although they require the inference that an additional animate cause can be inferred to be causal to the sending event either via metonymy or by contextual givenness. An inference is not a semantic property of a particular role but is an assumption based on a hearer's appraisal of the language he hears, the context it is in, and his knowledge of the world. This makes reference to *animacy* or *willingness* subject to the effects of factors that are outside of the semantics proper.

- (163) a. *The mail bag sent a letter to John.
- b. PayPal is great! The software can forward money to your account.
- c. Amazon shipped a book to John.

2.17.2. Problems with the compatibility of verb and construction

The compatibility between a verb and a construction is not only based on the fit between verb and construction roles. It is also determined by the harmony of the construction's semantics and the verb's semantics:

"Commonly, the event type designated by the verb is an instance of the more general event type designated by the construction." (Goldberg, 1995: 60).

For example, *hand* or *give* denotes a transfer type event and the semantics of the double-object construction denotes a cause-to-receive event.

- (164) Sam handed/gave Laura the keys.

However, many verbs that do not directly encode a transfer meaning can appear with a double-object construction. In (165), there is nothing in the semantics of *make* that suggest that a transfer has taken place, even though *Sam* may have the intention of doing so. However, it should be noted that the notion of transfer in (165a) is only a possible entailment of the event, indicated by the fact that it is defeasible (165b). Defeasibility is a typical property of pragmatic constraints, in contrast to semantic constraints which should not be dependent on pragmatic reasoning. It is then difficult to make the claim that the notion of transfer is stored in the construction's entry in the lexicon.

- (165) a. Sam made Bill some scones.
b. Sam made Bill some scones but he ate them himself.

Examples like (165) motivated Goldberg's (1995) claim that constructions can be polysemous; they have distinct but related meanings. These are referred to as a construction's 'extended senses' (cf. Goldberg, 1995: Ch.2.). This is based on Langacker (1991: 294-295), who argues that language revolves around *conceptual archetypes* and claims that "it is natural that such archetypes should be seized upon as the prototypical values of basic linguistic constructs". On this view, a construction is associated with a basic core meaning that is present in every instance of a particular construction. I will take Goldberg's (1995) analysis of the cause-to-receive construction as a case in point. Goldberg (1995) claims a construction is associated with a set of related senses rather than a single abstract sense. "Each of the extensions constitutes a minimally different construction, motivated by the central sense." (1995:86). For the cause-to-receive construction she provides the examples in (166).

- (166) a. X causes Y to receive Z (central sense):
Joe gave Sally the ball.
b. Conditions of satisfaction imply X causes Y to receive Z:
Joe promised Bob a car.

- c. X enables Y to receive Z:

Joe permitted Chris an apple.
- d. X causes Y not to receive Z:

Joe refused Bob a cookie.
- e. X intends to cause Y to receive Z:

Joe baked Bob a cake.
- f. X acts to cause Y to receive Z at some future point in time:

Joe bequeathed Bob a fortune.

In (166), the central sense of the construction is (166a) which functions as the semantic prototype for all the extended senses of the cause-to-receive construction. However, the extended senses of the cause-to-receive construction that she proposes seem to derive the unique point of their meaning from the verbs that they are set up to account for. For example, in (166b), the transfer event is possible but dependent upon meeting conditions of satisfaction. The problem is that the conditions are satisfied by reference to the act denoted by the verb, and not some element of the construction. “Conditions of satisfaction of the promise are not just that an act should occur, but it should occur because of the promise. Thus, the conditions of satisfaction of the promise are causally self-referential to the promise itself [...]” (Searle, 1983: 9). Moreover, it is hard to see how the double-object construction itself contributes the negative feature of the cause-not-to-receive extended sense in (166d) that is distinct from the verb’s own sense. If the negative sense of cause-to-receive is exclusively the domain of the construction, then one would expect ambiguity as to whether any given double-object construction is construed as a cause-to-receive or cause-to-not-receive construction. However, a sentence like (166d) unambiguously has the cause-to-not-receive sense, whereas a sentence like (166a) has not. Moreover, Goldberg’s (1995) analysis does not explain why verbs with a similar sense to that of the verb *refuse* are not licensed with the cause-to-receive construction as I show in (167). This suggests that the licensing of a construction is subject to unpredictable idiosyncrasies as some verbs can be admitted in the cause-to-not-receive extended sense whilst others with very similar senses are blocked.

(167) a. Joe refused/denied/*disallowed/*forbade/*blocked Bob a cookie.

A similar claim can be made for the intend-to-cause-to-receive sense of (166e). The verb *bake* is claimed not to encode a sense of *giving* aside of the contribution of the double-object construction. This means that *bake* should not have a sense of giving when it appears with other kinds of constructions that do not themselves encode a cause-to-receive sense. However, when *bake* appears in the so-called benefactive construction in (168), there is a sense in which *John* intends for *Mary* to receive *the cake*. Verbs that take part in this construction only differ from dative verbs in that the NP2 argument is introduced by the preposition *for* rather than *to*.

(168) Joe baked a cake for Mary.

Verbs that appear in the benefactive construction “can be broadly characterised as either verbs of obtaining or creation.” (Levin, 1993:49). As such it is difficult to extract the obtaining element of a *giving* event solely from the construction. It is unclear where the division of semantic contribution lies; one cannot claim definitively that it is the construction that contributes the cause-to-receive meaning. Goldberg’s (1995) analysis also cannot account for benefactive verbs which do not appear in the double-object construction and have an unambiguous sense of giving or transfer of ownership, as I show in (169). There is nothing about the semantics of the verbs that suggests that they are incompatible with the construction.

- (169) a. *John obtained Peter a new car.
b. *Sam retrieved Mary the car.
c. *The architect selected the couple a house. (Levin, 1993: 49. Her 123)
d. *Joe manufactured Mary a chair.

The verb *give* is also problematic in this respect. When it is used in a dative construction, CxG predicts that a cause-motion meaning is generated. However as observed by Rappaport Hovav and Levin (2008), the *give* type verbs in (170) only have a possessional reading.

(170) a. John gave/handed/lent the books to Mary (?but she didn't receive them).

Some verbs also appear in a double-object construction, yet their respective sentences are not associated with any of the extended senses of cause-to-receive as proposed by Goldberg (1995), such as those in (171). These verbs can only be classified in CxG as exceptions.

- (171) a. Sam bet John fifty pounds.
b. The textbook cost me fifty pounds.
c. I envied you your intelligence.
d. Mary begrudged John the money.
e. I saved/spared John the hassle.

It is also the case that all the verbs that can appear under Goldberg's (1995) central sense do not consistently guarantee successful transfer (van der Leek, 1996) such as the verb *throw*. In (172), all the verbs are usually compatible with the core sense of cause-to-receive, and the event participant *John* can be viewed as a volitional *agent* and the event participant *Mary* cannot be viewed as an (explicitly) unwilling recipient. However, the sense of successful transfer appears to be heavily context dependent.

- (172) a. John threw Mary the ball (but his aim was off).
b. John faxed Mary the new designs (but she wasn't in the office).
c. John passed Mary the glass (but she was too far away to reach it).

This data suggests that the sense of *intend* belongs more to the core meaning than to an extended meaning, and it is the context that determines whether transfer is successful. The 'meaning' associated with a construction in any given utterance appears to be, in part, a function of the particular linguistic context in which it is embedded. Following Langacker (1987), a construction cannot provide a fixed generalised expression for every conceivable situation that a speaker may wish to describe. There must be some way to account for the differing effects of context in the interpretation of a construction. Goldberg (2006: 36) acknowledges that there is "more to the interpretation of a clause than the argument structure construction used to express it." However, how labour is divided between verb, construction, and context is not made explicit.

Goldberg's (1995) approach also does not account for why certain verbs are licensed to appear in an alternation whereas verbs with very similar semantics are not. This occurs with verbs that profile compatible roles for the construction, and have compatible semantics with the construction. For example, there is nothing about the verbs *throw* and *put* in (173) that entail an (intended) transfer of ownership yet *throw* can be used with a double-object construction whereas *put* cannot. Both verbs can however be used with the dative construction.

- (173) a. Sam threw John the ball.
a'. Sam threw the ball to John.
b. *Sam put the garden the dog.
b'. Sam put the dog in the garden.

Given the right context, a dative construction with *put* can yield a sense that ownership has indeed been transferred.

- (174) a. The Major put the medal on the soldier (*but he dropped it).
 b. *The Major put the soldier a medal.

Moreover, the dative construction should yield a conceptual path if it is directly associated with a cause-motion construction (or one of its extended senses). As we can see, the sentence in (175a) does not readily incorporate this sense. The unacceptability of (175b) suggests that the path is determined by the semantics of the verb rather than the semantics of the construction.

- (175) a. ?The Major gradually/progressively/put the medal on the soldier.
 b. *The major put the medal toward/to the soldier.

A similar restriction can be seen with verbs of communication. Only certain verbs of communication can appear in the dative alternation, whereas others are restricted to appear with only the dative construction as shown in (176). It is unclear what semantically distinguishes these verbs without resort to idiosyncratic stipulations and lexical conservatism, as the kind of path that is acceptable is dependent on the verb.

- (176) a. Sam told/wrote/recited/mentioned/articulated/whispered/narrated/shouted a story to Mary.
 b. Sam told/wrote/recited/*mentioned/*articulated/*whispered/*narrated/*shouted Mary a story.

As I have shown, the semantic constraints given in Goldberg (1995) are either too strict to account for the admission of so-called exceptions, or they are too general and do not accurately capture restrictions in the licensing of verbs and constructions. I now move on to her account of the *with*-variant construction, which is claimed to be a transitive causative construction with the addition of a *with*-adjunct; this yields a change-of-state interpretation with a specified *instrument*.

2.17.3. Problems with the Construction Grammar account of the *with*-variant construction.

The *with*-variant construction is an interesting case for this thesis. In the first instance, it is one of the few constructions in which Goldberg makes reference to some kind of formal structure which can be tested. Secondly, in this thesis I claim that the *with*-variant construction has the same structure as the double-object construction. In the CxG approach, this is impossible because each is associated with a distinct meaning. A double-object construction is a distinct construction with its own associated generalised meaning. The *with*-variant construction is a ‘special case’ as it is not one complete construction; it is a composition of a construction that is associated with its own distinct semantics – a causative meaning – with the addition of an extra phrase which can be optionally expressed. The overt expression of this extra element is determined by pragmatic principles. Goldberg (1995) also claims that the *spray/load* verbs that appear with this construction lexically profile three participant roles. Recall that the Correspondence Principle needed an additional stipulation in order to account for this. The optionally expressed argument was given an *instrument* interpretation. I now show that this analysis of the *with*-variant construction is wrong. Firstly, I show that the *instrument* interpretation of the *with*-PP is problematic as it does not behave like other expressions traditionally interpreted as instruments. Moreover, if this interpretation is part of the lexical profile of the verb, then the *instrument* interpretation should not be affected by changes in the context. We will see that this is not the case. I then argue that the status of the *with*-PP as an adjunct is also problematic as it does not behave like other expressions traditionally interpreted as adjuncts.

2.17.3.1. Problems with an *instrument* analysis

Goldberg (1995) argues that the participant mapped to the *with*-PP functions as an instrument that facilitates the action of a causative event. It functions as an intermediary between an *agent* and a *theme*. This means that the constructions in (152) repeated below in (177) are essentially the same. In both cases the *with*-PP is the tool with which the state of the argument interpreted as a patient is changed. In (177a) it is a tool used to make forcible contact with the *theme* and in (177b) it serves to facilitate the ‘loaded’ state of the *theme*.

- (177) a. Sam hit Bill with a stick.
b. Sam loaded the wagon with hay.

However, the *with*-PPs of spray/load verbs do not consistently act like instrumentals for all spray/load verbs. Goldberg (1995) attempts to consolidate the data by dividing the spray/load class of Levin (1993) into five distinct semantic groups following the work of Pinker (1989) (cf. Goldberg, 1995: 176-179), yet the members of these classes do not behave alike in respect to *instruments*. Recall that an instrument can be the subject of a causative construction (178), whereas this can only occur for some verbs in the spray/load class. Examples (179) to (182) demonstrate the conflicting behaviour of members of Goldberg's spray/load subsets. In some cases, the *with*-PP appears to behave like the instrument in (178), as the participant it is associated with can appear as a sentence subject when a [+c] or [+c +m] cluster is absent. In other cases, this structure is impossible or degraded.

(178) a. Sam hit Bill with the stick.

a'. The stick hit Bill.

(179) *The Slather Class*

a. Sam rubbed the lamp with the cloth.

a'. *The cloth rubbed the lamp.

b. Sam smeared the table with Jam.

b') ??Jam smeared the table.

(180) *The Heap Class*

a. Sam heaped the plate with potatoes.

a'. Potatoes heaped the plate.

b. Sam piled the floor with bricks.

b'. *Bricks piled the floor.

(181) *The Spray Class*

- a. Sam sprayed the wall with paint.
- a'. Paint sprayed the wall.
- b. Sam injected the man with insulin
- b'. *Insulin injected the man.

(182) *The Cram Class*

- a. Sam packed the cases with the marijuana.
- a'. Marijuana packed the cases.
- b. Sam stuffed the envelopes with the money.
- b'. The money stuffed the envelopes.

(183) *The Load Class*

- a. Sam loaded the truck with the hay
- a'. *The hay loaded the truck.
- b. Sam stocked the shelves with books.
- b'. *The books stocked the shelves.

Kamp & Rossdeutscher (1994) observe that all instruments are not alike. They argue that 'instrument' is a label that describes two distinct subsets – one in which the instrument is auxiliary to the agent action (184a), and another in which it can be construed as acting independently once an appropriate action has applied or introduced it (184b). Only the latter kind of instrument can become a subject as they are construed as *causers*. A similar observation is made in Levin and Rappaport (1988).

- (184) a. The doctor cured the patient with his scalpel.
 b. The doctor cured the patient with camomile.

Kamp & Rossdeutscher (1994: 143)

This seems to accurately capture the licensing restriction in (179) – (183). For example, in (180a), the verb *heap* refers either to the causative event of putting objects into an unordered pile, or a stative event, where objects lie in an unordered pile. Because of the ‘lie’ reading of *heap*, *potatoes* can be construed as having a causal part to play in the *heaping* event. A capability for *heaping* is construed to be a property of the unaffected state of the *potatoes* themselves. With the right construal, this means this role can be inferred to be causal to the event. Because of this, the actual instigator of the action can be optionally expressed (180a’). The interpretation of *pile* is in contrast to that of *heap*. In (180b) the agent of the *piling* is obligatorily expressed. This is because the dominant meaning of *pile* differs from *heap* in that the former describes the placing of objects with a specific intentional manner. This is something that requires an outside force to initiate – an *agent*. The participant corresponding to the *bricks* in (180b) can only be construed as being capable of having a piled state by the direct action of an agent; as such it cannot be assigned a causal role to the event. The ordered action of piling is not an intrinsic property of the bricks that can occur without the effect of an outside force. The role corresponding to the *bricks* can only be given the interpretation that its participation in the event is a necessary condition for the event to occur – the manner of piling cannot occur without a ‘pile-able’ participant. This can be viewed as its enabling function (e.g. Shen, 1985) rather than its distinctiveness as an instrument. This is only a possible featural property of a referent like *bricks* (notice the difference with *Sam piled the floor with the bricks*/**the water* and ?*Sam heaped the plate with bricks*). This distinction may account for why (in a *with*-variant construction) this participant is obligatorily expressed with *pile* and optionally expressed (although somewhat degraded) with *heap* as I show in (185).

- (185) a. *Sam piled the plate.
 b. ??Sam heaped the plate.

From a CxG perspective, it is unclear how these two different *instrument* interpretations can be handled without losing a generalisation about the construction with which they appear. It is only with

reference to the event schematic properties of the verb rather than that of the construction which determines the kind of event that is being described.

From a Theta System perspective, the lack of a general causal interpretation for an obligatorily profiled argument means that the [c] cluster in verbs like *pile* is either underspecified or negatively valued. This means that the only possible clusters for this role are either [-m], [-c -m], [-c], [-c +m], or [+m]. Recall, that a positive /m feature suggests that the participant can be construed as animate, and a negative /m feature means that the mental state of this participant is irrelevant to the argument structure. As can be seen in (186), the presence of an animate entity in the *with*-PP is possible although only by metaphorical extension. This argument must therefore be assigned the feature /-m as the mental state of this participant is not directly relevant to the argument structure of the event. (I use # to indicate that the example is semantically anomalous.)

- (186) a. #Sam rubbed the carpet with the boys.
b. #Sam smeared the floor with the people.
c. #Sam sprayed the wall with the teenagers.
d. #Sam injected the patient with Mary.
e. ??Sam heaped the bed with the children.
f. ??Sam piled the floor with the pensioners.
g. ?Sam stocked the classroom with students.
h. Sam packed the hall with people.
i. Sam stuffed the carriages with commuters.
j. Sam loaded the truck with refugees.
k. Sam filled the classroom with students.

Reinhart (2002) proposes that *spray/load* verbs fall into the larger class of manner verbs. Manner verbs are divided into those that list the cluster corresponding to the *with*-PP argument as [+c -m]

and those that list it as [-c]. Whilst this can account for the distribution in (179) – (183), this would be problematic for my account in which the constructions in an alternation carry a similar meaning. Recall that in the locative variant construction, the argument that corresponds to the *with*-PP argument in the *with*-variant construction is interpreted as a *theme* and thus has the cluster [-c -m]. However, in order to maintain our generalisation for the lexical specification of these verbs, I claim that the data can be accounted for by the underspecified cluster [-m]. In this way we can account for both the *theme* interpretation in a locative variant construction and the *instrument* interpretation in the *with*-variant construction. Reinhart (2002: 233) acknowledges that [-m] can be viewed as a sufficient condition for a cause interpretation in an appropriate context. If the properties of an argument cannot be viewed as a sufficient condition to be interpreted as a cause, it must be a [-c] cluster. As was argued above, the enabling function is a sufficient condition for a causal construal and so the cluster mapped to the *with*-PP in the *with*-variant construction of spray/load verbs must consistently be [-m]. Therefore, the change-of-state-plus-instrument interpretation can only be an inference rather than it being intrinsic to its entry in the lexicon. The possible inferences associated with this argument mean that the [-c] cluster must occur higher in the hierarchy than [-m] as a cluster associated with a *theme* inference appears structurally lower than an inferred *goal*. What is important is to state that the semantic analysis that Goldberg (1995) proposes for the *with*-variant construction does not adequately account for the data as the *with*-PP is not an instrument by default. An appeal to the verb's semantics can give a more accurate account for of the roles of participants in the *with*-variant construction. This also means that the status of the *with*-PP as an adjunct is brought into question. I now turn attention to this problem for CxG.

2.17.3.2. Problems with an *adjunct* analysis

A second problem for the CxG analysis of the *with*-variant construction comes from the classification of the *with*-PP as an adjunct. Firstly, it is not standardly assumed that an adjunct can be associated with an obligatory object argument of the verb in a neutral context as proposed in Goldberg (1995). By definition, an adjunct is a label for an optionally expressed phrase, and an obligatorily profiled argument is one that requires expressing in a neutral context. Following Grimshaw (1993), verbal arguments are always expressed in active sentences in a neutral context. For the structural analysis of the spray/load alternation proposed here it is essential that the evidence can show this. I agree with Goldberg (1995) that an argument can be optionally expressed depending upon contextual requirements, but it is nevertheless a verb's argument and so should behave like an argument and

not an adjunct. The first test is the non-suppressibility of arguments (Hole, 2015)⁴⁶, as expressed in (187).

(187) A constituent C of a simple declarative non-negated sentence S is an *argument* iff (i) S is ungrammatical without C, or (ii) S is grammatical without C, but entails the C relation (where “the C relation” is the semantic relation that links the content of C to the eventuality described by S).

(Hole, 2015: 1286. His 2)

This means that a constituent such as *spaghetti* in (188) is an argument because there is an entailment that *Sam* ate something.

(188) Sam ate (spaghetti).

We can contrast this with the status of adjuncts, for which Hole (2015) proposes the following criterion in (189).

(189) Suppressibility of adjuncts

A constituent C of a simple declarative non-negated sentence S is an adjunct iff (i) S is grammatical without C, and (ii) S without C does not entail the C relation.

(Hole, 2015: 1287. His 3)

This means that the *with*-PPs in (190) selected from each of Goldberg’s (1995) semantic classes can all be considered arguments as the action denoted by these verbs describes an event in which a third

⁴⁶ This is essentially a fusion of Jacobs’ (1994) *Obligatoriness* and *Participation* conditions for argument status.

participant is entailed. A similar argument is given for spray/load verbs in Koenig, Maurer and Bienvenue (2003). Compare the contrast in (191) where no other participant is entailed.

- (190) a. John smeared the wall (with something).
b. John heaped his plate (with something).
c. John sprayed the wall (with something).
d. John packed the boxes (with something).
e. John loaded the truck (with something).

(191) John made a cake.

Next, following Schütze (1996), arguments appear with a more restrictive range of heads than adjuncts. The PP *of Parliament* is an argument and *with gray hair* an adjunct according to (187i). The PP *of Parliament* has a more restricted distribution than the PP *with gray hair*.

- (192) a. A man/woman/dog/Muppet/scarecrow *with grey hair*.
b. A member/*dog/*Muppet/*scarecrow *of Parliament*.

If the *with*-variant construction is a true adjunct as proposed by CxG, the non-instrumental *with*-PP should be licensed in many types of contexts. However it is restricted to a subset of spray/load verbs.

- (193) a. John sprinkled the cake with coconut.
b. *Sam placed the table with shopping.
c. *I broke the table with books.

- d. *I poured the glasses with water.
- e. *John rolled the tube with paper.

Dowty (2003), Merlo and Esteve Ferrer (2006), and Schütze (2012) argue that we can understand the semantic contribution of the PP independently of the verb if it is an adjunct, as (194) illustrates. The appropriate meaning for the PPs in (194a) and (194b) can be determined without knowing what the verbs were; indicating that they are adjuncts. This is not the case for (194c) and (194d) where the verbs *invest* and *jump* provide information in how to interpret the preposition *in*.

- (194)
- a. My friend arrived in a car.
 - b. The escapee foraged in the woods.
 - c. My friend invested in a car.
 - d. The escapee jumped in a car.

(Schütze, 2012: 2. His 1 and 2.)

The *with*-PP is reliant on the verb's semantics to understand the relation to the other object NP as I show in (195).

- (195)
- a. I loaded the truck with the boxes = The boxes are ON the truck.
 - b. I packed the room with people = The people are IN the room.
 - c. I wrapped the box with brown paper = The paper is AROUND the box.

Recall that constituency is a diagnostic of argumenthood. A constituent is formed between a head and an obligatory complement (196a). A constituent is still formed by a head that does not select an obligatory complement irrespective of the presence of an adjunct (196b).

- (196) a. John hit *(Sam).
b. John sang (with Sam).

Schütze (2012) observes that for a given head two argument PPs can be given in any order as the double prepositional complement structure in (197a) shows. Similarly, two adjunct PPs can appear in any relative order as (197b) shows. However, when an argument PP and an adjunct PP are co-present, the argument PP must precede the adjunct as (197c) and (197d) illustrate. It should be noted that this ordering requirement applies to underlying orders only and prior to any Information Structural devices for the strategic structuring of information. As such, caps are used in the examples to indicate a prosodic emphasis on the non-final PP to prevent derived word orders from sounding acceptable (cf. Pollard and Sag, 1987).

- (197) a. They complained to the LANDLORD about the tenant/about the TENANT to the landlord.
b. A politician from Paris with grey hair/ with grey hair from Paris.
c. A member of Parliament with grey hair/*with grey hair of parliament.
d. They complained to the LANDLORD after the flood/*after the FLOOD to the landlord.

(Schütze, 2012: 4. His 6 and 7.)

According to this diagnostic, the *with*-PPs in *spray/load* verbs are arguments as they cannot be preceded by an adjunct PP as shown in (198).

- (198) a. Sam loaded/sprayed the truck on Saturday.
- b. *Sam loaded/sprayed the truck on SATURDAY with paint.
- c. Sam loaded/sprayed the truck with PAINT on Saturday.

The data given in this section has brought into question the adjunct status of the *with*-PP in Goldberg (1995). I have shown that the *with*-PP does not behave normally in respect to other adjuncts either semantically or distributionally, and in fact resembles an argument according to the diagnostics provided. It will be seen in chapter 3 that the *with*-PP also behaves more like an argument syntactically. Conceptually, it is hard to see how a verb on the one hand is blocked from projecting an argument structure – it is the task of the construction – and on the other hand is licensed to project an argument which attaches onto a semantically incomplete form-meaning correspondence. In the case of this construction, the CxG account is severely weakened by allowing more contribution from the verb which can provide structural material in order to complete a construction. It is not clear why this structure in particular is licensed to be affected by the semantics of the verb, whereas other constructions are holistic structures that are semantically impenetrable in respect to their event semantics and block any additional contribution to the structure that may impact on the structure of the event.

One further point that requires highlighting as it is relevant to the discussion in the next section is the contribution of context to the selection of a construction. Goldberg (1995) explicitly argues that the only relevant contribution of context “involves particulars of Information Structure and stylistic devices (such as metaphorical extensions).” (1995: 67. *My parentheses*). This constrains aspects of the context from interfering with the semantic meaning of the construction. In other words, a cause-motion construction means *cause motion* rather than *cause motion* being an inference based on a structural formation whose form is influenced by the context in which it used. Goldberg (1995) allows strategic devices employed by a speaker in respect to the context of the utterance to omit an obligatory object such as the *with*-PP (cf. the maxim of Quantity above). If the effect of context is restricted to the strategic structuring of the speaker of which he is aware (on some level), then features of the context that may incur a stimulus-response effect rather than a ‘do-I-need-to-mention-in-a-particular-way’ strategy should have no effect on the preference for a particular construction. As I show in the following section, however, many features of our visual environment do indeed influence preferences for word order and thus impact on the preference for a particular construction over another.

2.18. The effect of context on argument order.

As shown in the previous section, the CxG approach claims that context can interact with argument structure in situations where the discourse warrants the restructuring of an utterance to suit some communicative purpose. In this thesis, I argue that the word order of arguments is indeed influenced by properties present in the discourse environment. However, I claim that argument structure is influenced by the context to a far greater extent than CxG allows. As well as features associated with the linguistic context, these include features that are linked to stimuli present in the environment – particularly visual stimuli. These features interact with the psychological concept of Attention which has repercussions for word order preferences (e.g. Nappa et al., 2004). Attention, as used here, is a term to describe the allocation of our mental resources when processing information. These processes originate in Working Memory (WM) (Posner and Peterson, 1990). Behavioural studies have shown that attention allocation can be influenced by visually orienting toward a target location (e.g. Myachykov, 2007; Myachykov et al., 2007; 2012). The claim that is made here is that items that are the focus of our attention tend to be referred to earlier in a sentence (Slevc, 2011). This is problematic for CxG because a difference in word order is not necessarily associated with a difference in semantics, but is triggered by a difference with how a scene is viewed based on non-semantic features of the context. Secondly it supports the thesis' view for the structure of the spray/load and dative alternations. Recall that the each variant in an alternation is identified by a distinct syntactic structure, but what motivates the differing word order in the first place is left unanswered. By allowing context to influence the word order of arguments, the difference in word order for each variant of an alternation does not have to be attributed to a change in thematic structure or a difference in event semantics; the participants and the event itself are the same, but the way the scene is processed differs. By appealing to the effects of context means that a difference in word order cannot be the result of a transformational process as arguments are derived in the linear position in which they appear; no movement is necessitated. The onus for a difference in the order of objects is put upon the (limited) way that human beings process information. The word order of arguments in these ambiguous structures is determined by processes outside of the syntax proper, so a syntactic process does not need to be proposed to account for it. Word order differences are then accounted for easily by reference to the psychological process of attention without resort to construction semantics.

In preparation, it is first necessary to set out what is meant by attention and how it can be focussed onto a particular feature. This is the topic of (2.18.1) in which we clarify the conventional terminology and describe how the human information system deals with the constant influx of information to be processed and how this impacts on sentence formation. The literature about contextual variables that

interact with attention is vast⁴⁷. In this chapter, I focus on a particular variable of the visual environment which has not been previously tested on the word order of the double-complement constructions used in this thesis. This variable is the subject of the experiment in chapter 5 – the egocentric perception of distance. For now, I begin the discussion with a brief description of Working Memory and attention.

2.18.1. Working memory

Working Memory (from here on WM) can be described as a mental workspace consisting of activated memory representations that are available in a temporary ‘buffer’ for manipulation during information processing (Baddeley, 2010). WM is a processing system for information. It only has the capacity to store small amounts of material for brief periods of time, which may or may not be available to consciousness (Baddeley, 1992), but is usually considered to be above some threshold of mental activation (Baddeley, 1986). WM, then, is a short-duration, limited capacity memory system capable of simultaneously storing and manipulating information in the service of accomplishing a task (Baddeley 1995). It is argued to play a critical role in goal-directed behaviour (Miller & Cohen, 2001), and it is a widely used resource employed in mental tasks such as problem solving, information retrieval, planning, intelligence, the processing of sensory information, and importantly, language production (e.g. Daneman and Carpenter, 1980; Engle et al., 1992; Moscovitch, 1992; Shallice and Burgess, 1993; Baddeley, 1996; Kronenberger, Pisoni, Colson & Henning, 2010). There are several competing accounts of the functional architecture of WM. The clearest distinction between the available models is between those that view it as a unitary, limited capacity system (e.g. Case, Kurland & Goldberg, 1982), and those that conceptualise it as a multi-component system comprised of specialised subsystems (e.g. Baddeley and Hitch, 1974; Baddeley, 1986). What is agreed by these models is that the processing and storage operations compete for a limited pool of resources. The research presented in this thesis does not depend on one particular theoretical model, as the important aspect is the overall limited capacity of the WM system (see Miyake and Shah (1999) for a comprehensive review of competing instantiations of WM).

⁴⁷ In chapters 4 and 5, I discuss the contextual variables that are relevant to the experimental design.

2.18.1.1 Attention and the selection of information

It is uncontroversial to state that we cannot respond to all the information that is available to us due to the limited capacity of our WM (e.g. Eriksen and St. James, 1986; Pylyshyn and Storm, 1988; Raymond et al., 1992; Pashler, 1994; Rensink, O'Regan, and Clark, 1997; Kristjánsson, 2006a; Lamy, Leber, and Egeth, 2012). There is also a consensus that representations in WM are not all equal. A subset of the information that is available for processing is given a privileged status, making them easily accessible for processing (e.g. Oberauer, 2013). For example, all things being equal, we are more likely to notice an object that is moving compared to one that is not; especially if it is moving toward us. (Franconeri and Simons, 2003). This means that some information is prioritised over other information. The selection process is regulated by *Attention*. Attention refers to the way we actively attend to information in our environment. It is the allocation of mental resources for the processing of information that is impinging on our senses (e.g. Styles, 2005). It is the way that at any given moment some information in the environment is enhanced and other information is inhibited. It is targeted toward information that is relevant or important (Olivers, 2009). We have an intuitive notion of what it means to 'pay attention' to something, but this implies that we are making a conscious decision to take notice of something. However, we may not choose to attend to a piece of information; it can be triggered by some property of the information itself. For example, in a noisy party environment you may be able to consciously attend to what a friend is saying to you. We can do this above the humdrum of all the conversations that may be going on around us. This fits well with the actively 'pay attention' notion of attention, where our attention is allocated for the accomplishment of a specific task. This has also been referred to as 'goal-directed' attention (e.g. LaBerge, 1995). If at the hypothetical party, someone drops a glass on a tiled floor, it is likely that you hear this noise above other audio stimuli in the environment and you turn to look in the direction of where you hear the noise coming from. The way that you notice this stimulus without consciously allocating attention to it is often referred to as 'stimulus-directed', 'stimulus-driven' (e.g. Jonides, 1981; Theeuwes, 1992, 1994, 2004; Yantis, 1993; Yantis & Jonides, 1984), 'bottom-up' attention, or exogenous control (e.g. Theeuwes, 1994). Attention is the allocation of processing resources to some information at the expense of allocating resources to other information (e.g. Desimone & Duncan, 1995; Egeth & Yantis, 1997) whether this is goal-directed, or stimulus-driven. In this chapter, focus is given to stimulus-driven attention. For a recent review on how goal-directed attention operates see Lamy and Kristjánsson (2013).

Attention allocation has been often referred to as a highlighting or spotlighting process (e.g. Posner and Petersen, 1990) as it makes the information 'pop out' (e.g. Treisman and Gelade, 1980). The

function of the spotlighting process is to make the highlighted information active in WM (Cowan et al., 2011). This information is active so that cognitive processes such as the conversion of conceptual information into linguistic material can be facilitated (van Dijck et al., 2013). As WM is a limited capacity system, the active information is processed and then discharged from WM as soon as possible to make way for the processing of other information (e.g. Baddeley, 1986). This means that information is to some extent processed incrementally. Processing incrementally in this way allows efficient management of WM so that processing load remains manageable. Information that is being processed uses up WM capacity, so the most efficient system is one that can discharge this information as soon as processing has finished so that the next item of information can be processed. Majerus et al. (2012) observed that in the serial recall of a visually presented series of consonants, neural activity increased in the areas responsible for attention as the length of the recall series increased. Neural activity decreased as items were verbally discharged⁴⁸. This study is evidence that attention is involved with verbal tasks in WM. The retention of verbal material uses up processing capacity, and the load is decreased when these items are discharged. The impact for an incremental processing model is that the most efficient system involves the rapid discharge of information that uses the most resources. “Thus, speakers can begin to generate and articulate an utterance as soon as minimal input is available, rather than having to wait until all elements of the utterance have been retrieved.” (Branigan et al., 2008: 174). Regulating the WM system by managing the information that captures attention ensures that WM does not become overloaded with voluminous amounts of processing at a particular time, or retain superfluous information that need no further processing⁴⁹. Such a system is needed for processing efficiency in a limited capacity resource (Lavie, 1995, 2005; Marois and Ivanov, 2005). For language, this means that an item to be reported which is currently the focus of attention tends to trigger the generation of syntactic structures that allow for the early production of this material (Slevc, 2011). Ferreira and Dell (2000: 289) call this the Principle of Immediate Mention: Production proceeds more efficiently if syntactic structures are used that permit quickly selected items to be mentioned as soon as possible. “Production is assumed to be radically incremental, greedily proceeding with whatever material is available first, wherever speakers have the choice to do so (i.e. where grammar permits it).” (Jaeger and Norcliffe, 2009: 869). In the absence of grammatical constraints or imposed structures, a referent which is the focus of attention tends to

⁴⁸ Interestingly, van Dijck and Fias (2011) observed a bias in left hand responses for items at the beginning of a recall series, whereas a right hand bias was observed for items toward the end of the series. Although anecdotal there is an indication that there is a leftist bias for items in a series that require early discharge from WM. The authors claim that this is due to items in verbal short term memory being spatially coded.

⁴⁹ Downing (2000) defines Working Memory as the active maintenance of a representation after the stimulus that produced it is no longer present.

determine a linear starting point for a structure (e.g. Fillmore, 1977); for our purposes this is the linear starting point of predicate arguments in a double-complement VP. In other words, in the conversion of a concept into language, the argument that is most prominent in the mind at the time of sentence formation can be identified by its linear position in that sentence⁵⁰. Information that has captured attention and is currently being processed in WM is referred to as being in ‘Attentional Focus’ (e.g. Castillo and Umiltà, 1990), or that it is the ‘Focus of Attention’ (Oberauer, 2002). The focus of attention is determined by the value of a particular property or properties of the item. It is the means by which information that was previously unnoticed becomes conscious and available for further processing (Horstmann, 2004). In this way attention capture initiates the preservation of information in WM for use in other WM subsystems (cf. Baddeley, 1986).

What is of concern here is the kind of bottom-up information that can affect the preference for a variant from the spray/load alternation and a variant from the dative alternation. The main experiment in chapter 5 tests the influence of the egocentric perception of distance on the preference for one of the constructions in the spray/load alternation and the preference for one of the constructions in the dative alternation, so in order to see if this feature does indeed interact with argument structure it is important to control other possible attention-influencing features in the environment in which it appears. These features are presented prior to the experiments in chapters 4 and 5 where it is explained how each of these features interact with attention and how they are accounted for in the experiments. What is presented here is the egocentric perception of distance as this is the variable of chief concern to the thesis, and is the topic of the following section.

2.18.2. The egocentric perception of distance

The term perceived distance is understood to be a representation of the extent of physical distance between two objects. It is not an absolute value of distance but an assumption of distance based on information provided by perceptual cues (Cutting and Vishton, 1995). Egocentric distance is the perception of distance from an observer to an object along a depth axis; that is, one that linearly extends away from the observer’s field of vision (Loomis and Knapp, 2003). As such, the perception of egocentric distance is a property only found in viewing 3-dimensional space or the depiction of 3-dimensional space. In a 3-dimensional scene, items can appear at varying locations along a depth

⁵⁰ We abstract away from Information Packaging strategies that place material in positions to make them salient to a hearer, such as using the subject position to make non-salient referents salient (e.g. Mulkern, 2007). These are considered to be post-syntactic top-down processes as they involve higher level sentence planning.

access, which means they can be located at different distances from the observer. Items are closer to the observer when they appear in the *foreground* relative to an item in the same scene that is located further away. An item is in the *background* when it is compared to another object in the same scene that is located nearer to the observer. In this way foreground items and background objects refer to segmented perceptual units that lie on different depth planes in a visual scene. The term background has traditionally been defined as a homogenous, undifferentiated surface (e.g. Champion and Warren, 2010). This is not dissimilar to a scene backdrop that fills the back surface of a theatre stage which actors and props are located in front of. This means that in a scene containing two items on distinct depth planes where one is nearer to the observer and one further away, and both can be distinguished from the *backdrop*, the nearer item is referred to as the foreground item, the further item as the background item. Any item that exists on a plane that cannot be differentiated from the backdrop forms part of that backdrop. Of course, many depth planes are possible, but our interest is in the relative distance relations between two items in a scene. The idea that a foreground item that stands out from a backdrop is more likely to capture attention than an item in the backdrop is not new (cf. Rubin, 1915/1958) and forms a significant body of literature (e.g. Metzger, 1953; Neisser, 1967; Marr, 1982; Julesz, 1984; Treisman, 1986; Hoffman & Singh, 1997; Vecera, Vogel, and Woodman, 2002; Vecera, Flevaris, and Filapek, 2004). The main difference with the study in this thesis is that any item that is not part of the foreground is not absorbed into the backdrop by default (e.g. Kienker, Sejnowski, & Hinton, 1986; Subirana, 1991; Grossberg, 1994; Vecera and O'Reilly, 1998; 2000; Salvagio et al., 2012). A referent can exist in the background that is independent of the backdrop. The aforementioned studies do not make a distinction in attention allocation between multiple items that stand out from a backdrop; they focus on how a single item pops-out against a backdrop. In a real world scene there are often multiple items that stand out from a backdrop. For example, when we are driving a car on a busy city street we can still distinguish and track individual vehicles and pedestrians both moving and stationary; they do not disappear into a homogenous mass. If it were not the case, the mortality rate of road users would be significantly increased. So how do we organise our processing of items that do not form part of a backdrop? This is achieved by means of 'depth cues' (e.g. Kaufman, 1974; Cutting and Vishton, 1995). In a real world scene, through a combination of multiple sources of information "we come to perceive, with reasonable accuracy, the layout of the world around us." (Cutting and Vishton, 1995:72). Entities in the real world are structured in particular ways that our visual system has evolved to handle (Henderson and Ferreira, 2004). In other words, our perception of the real world is constrained by our interpretation of specific visual cues that allow us to make assumptions as to how that world is structured. This is especially true of distance perception as we only receive information from two dimensions. Features of this information lead us

to believe that we are actually viewing images in 3 dimensions. The list of cues that have been proposed to provide distance information is formidable. Cutting and Vishton (1995) identify fifteen separate features based on a review of the literature. However, it is not necessary for each feature to be present in a scene for the perception of depth to be communicated, and it is commonplace for experimenters to combine reduced bundles of features to cue the perception of distance. It has been pointed out in Landy, Maloney, and Young (1991) that a single source of depth information may leave one or more parameters about depth unknown, and so the addition of cues can add to the weight of distance and depth perception. "An observer's utility to perceive distance varies with a number of circumstances, most prominent of which is the degree to which the experimental situation makes available information for distance." (Sedgewick, 1986: 22). As a full complement of depth cues is not needed to trigger an impression of depth, only the cues that influence distance perception used in the experimental images are given; these are relative size, and height in the visual field. (See Cutting and Vishton, 1995, and Loomis and Knapp, 2003, for a comprehensive typology of possible depth cues.)

2.18.2.1. Relative size

Relative size is the measure of the projected size of objects on the retina that are physically similar in size but vary in distance. If an object is familiar then an absolute size is more or less known to the observer. This means that the observer can estimate the size of an object based on real world knowledge about the object's typical size properties. When more than one object is present in a scene, an observer can estimate which object is nearer based on the relative size of the two objects to each other. When two objects on differing depth planes are not intrinsically of a similar size then an object's size can also be estimated based on a comparison with other contextual objects that may exist on the same depth plane. This can give an additional clue as to whether this object is nearer or further than another. Cutting and Vishton (1995) claim that the relative size of an object is a trusted feature of distance judgements.

2.18.2.2. Height in the visual field

This cue is the projection of a relation with the base of an object in a 3d environment. The idea is that if two objects are depicted as touching an unobscured ground, the one that is further away from the observer will appear higher in the visual field than the one that is nearer (Gibson, 1972; Ooi, Wu and He, 2001). It allows the determination of the vertical extent of the object based on the viewer's eye-

height and the angles from the top to the bottom of the object. It has been shown that under normal viewing conditions with a clearly visible ground plane, the height in a visual field supports distance judgements to around 20 metres (Gardner and Mon-Williams, 2001; Ooi, Wu and He, 2001).

2.18.3. The egocentric perception of distance and its effect on attention

It has been shown that distance perception can be triggered by cues in a visual scene. What needs to be addressed is when two objects differ in their relative egocentric distance so that one object is in the foreground, and the other object is in the background, the question remains as to which one becomes the focus of attention. Mazza, Turatto, and Umiltà (2005) provide an answer to this question. They employed a change-blindness experiment to test attention allocation with foreground and background objects. A change blindness experiment is viewed as an effective tool for examining the allocation of attention (Rensink, 2002). Change blindness refers to the phenomenon that occurs when some change to the visual environment is introduced and the observer does not notice it. It is claimed that this is due to the limits of the attention system and it is consistent with the view that attention capture is necessary to see change (e.g. Rensink, 2005). The stimulus that has been changed and is unnoticed is said not to have captured the current attention of the observer. This can occur with large scale changes and with the full knowledge of the observer that these changes will occur (Rensink, 2002). Attention is usually captured by a disturbance in some part of the visual scene accompanied by a structural change to some other area. If the disturbance captures the observer's attention then the change goes by unnoticed. Focused attention is required to perceive any change (Rensink, 1997). Mazza, Turatto, and Umiltà (2005) presented twenty one participants with a schematic visual display consisting of a set of 6 horizontal and 20 vertical rectangles. Distance information was cued by occluding the vertical rectangles with the horizontal rectangles⁵¹. The item that is being occluded appears to be further away than the item that is occluding it. In Mazza, Turatto, and Umiltà (2005) the vertical rectangles appeared in the background whereas the horizontal triangles appeared to be in the foreground. They presented three sets of trials: a change in the foreground objects, a change in the background objects, and a no change trial. A change trial consisted of two displays that were presented 500ms apart; a default display and a changed display. In each trial, the vertical rectangles consisted of two colours which varied across trials. The background consisted of 20 alternately coloured columns, each consisting of 10 vertical rectangles. Each rectangle in the background was

⁵¹ Occlusion refers to the obstruction of an object (either partially or completely) by another object. It is a well documented source of distance information (e.g. Ono et al., 1988).

separated by a blank space. This blank space corresponds to the definition of *backdrop* used here. The foregrounded horizontal rectangles were arranged in a circular manner around an imaginary central circle. Two pairs of equiluminant colours (red and green, and blue and purple) were used for the rectangles which varied across trials and were counterbalanced between participants. The foreground changes consisted of all the horizontal rectangles changing colour (e.g. red changed to green and green changed to red). Similarly the background change consisted of all the vertical rectangles changing colour. Colour combinations varied across trials so that participants did not view the same colour consistently for a particular depth plane, diminishing any effect that colour may have on attention capture. Participants were not given any instruction concerning which set was the foreground or the background, they were only instructed that the display would consist of rectangles at different orientations. This was to prevent any explicit top-down goal-directed assignments. The trials were arranged into four blocks. The first two blocks consisted of 90 trials (30 foreground change, 30 background change, and 30 no change trials). The third and fourth blocks consisted of 60 trials each (30 no change, and either 30 background change or 30 foreground change trials). Trials were organised into two conditions: a default attention condition, and a divided attention condition. Before the first block, participants were informed that if there were a change, it would take place in the rectangles. This was the default attention condition. Before the second block of trials, participants were told that the change when it occurred could appear as often in the horizontal or vertical rectangles. This was to influence participants to pay attention to both sets of rectangles. This they called the divided attention condition. Before the third and fourth blocks, participants were informed that any change that would take place would occur in the rectangles that were indicated at the beginning of the block; i.e. a change in the vertical rectangles, or a change in the horizontal rectangles. Blocks three and four were counterbalanced between participants. A trial began with a warning signal that lasted for 500ms. Then the first and second displays were presented for 500ms each, separated with a blank screen which lasted for 200ms. Participants indicated any change by pressing one of two keys on the keyboard. The results of this experiment showed a significant attentional preference for the foreground rectangles in the default and divided attention conditions. In the default condition participants were “virtually blind to the background change.” (Mazzo, Turatto, and Umiltà, 2005: 205). As focused attention is required to notice a change, the background elements were not the focus of attention. In the divided attention condition, even though participants were aware that a change could take place in either the background or the foreground rectangles, participants noticed the change in the foreground rectangles more often. This suggests that the foreground is more effective at capturing Attention. The results of the third and fourth blocks of trials showed that it was not a difference in the visibility of objects at different depths that may be the influencing factor. Background changes were

not more difficult to perceive because they were physically further away in comparison to foreground items. They were more difficult to perceive because attention was captured by the foreground objects. Mazzo, Turatto, and Umiltà (2005) conducted a second experiment with the same method as the first except half of the foreground rectangles were not arranged in a circle around the centre of the display but were randomly dispersed around the centre. This was to mitigate any advantage for the figural configuration of the circular arrangement to capture attention. The results of this experiment replicated the results of their first. This study shows that the allocation of attention is indeed affected by the relative positioning of objects in a scene. So here we have a precedent for the effect of the egocentric perception of distance on attention. I now present a study which shows that this effect is significant for argument order preference.

Vogels, Krahmer, and Maes (2013) investigated two possible effects of the egocentric perception of distance on language form: the effect on the kind of referring expressions used, as well as the order that these referring expressions occurred in spoken language. They hypothesised that referents that captured attention would be chosen more often as first referents, and that referents that captured attention would be referred to more often using reduced expressions (e.g. he vs. the man in the hat) as predicted by Accessibility theory (e.g. Ariel, 1985b, 1988). They conducted their experiment on native speakers of Dutch. The materials for the experiment consisted of twelve short stories. Each story consisted of two photographic images showing one male and one female character in a particular situation. The first picture was accompanied by two sentences and the second picture was aligned with the onset of a prompt. The prompt contained only the adverb *Daarom* (therefore) and participants' task was to complete the sentence by producing an appropriate utterance that described the second image. In the second image one character always performed an action (the agent), the other character did not move. The perception of distance was manipulated by the agent being shown centrally in the foreground, partly occluding the static character, or in a more peripheral position in the background being partly occluded by the static character. The results showed that participants were more likely to choose the foregrounded agent as the subject than the background agent, suggesting that the perception of distance from the participant was the influential factor. "Participants used the visual salience of an entity to determine whether they would refer to it first (as the subject), but not to determine whether they would refer to it with a pronoun or a full NP." (Vogels, Krahmer, and Maes, 2013: 1332). It was found that the form of a referring expression was influenced by the linguistic context. The results of this study suggest that visual attention operates independently of the linguistic context. It also showed that there is limited influence of the linguistic context on the word order of referring expressions, and a limited influence of visual attention on the form of the referring expression. The fact that visually foregrounded referents are more likely to be referred to as subjects

indicates that the spatial location of the referents in the pictures is a feature that influences sentence choice. This finding is taken to be a difference in word order triggered by spatial position. This thesis makes the claim that this effect is not only reserved to whether a referent is chosen as a subject but is operational in word order preferences in general. It is predicted that the egocentric perception of distance influences preference for a construction from the spray/load and dative alternation as a referent that corresponds to one of the grammatical objects in an alternation (NP1 or NP2) will be referred to first if it is perceived as relatively closer than another referent that corresponds to the other grammatical object. These studies show that distance information has an effect on the order that objects in a scene are processed which has consequences for how the scene is reported. This means that of two objects, the one that is processed first corresponds with the referring expression that appears earlier in a sentence. In terms of the egocentric perception of distance, the closer the referent, the earlier its referring expression appears in a sentence. This is significant to this investigation as it places the motivation for word order differences of the spray/load and dative alternations not on semantics or syntax but on the (visual) context.

2.19. Chapter summary

In this chapter I have given an account of syntax, thematic structure, semantics, and the effect of context in regard to the variants of the spray/load and dative alternation. Firstly, thematic structure was discussed and the model of the Theta System of Reinhart (2000; 2002) was outlined. In this model, theta roles are not semantic primitives of the system but are semantic inferences, the implication of which is that the fine distinction of thematic labels does not determine argument structure. The Theta System is actually a formal coding of two binary feature specifications; [c] and [m]. This feature specification is called a cluster and is visible to both the syntax and the semantic inference system. It is the specification of a cluster that interacts with the syntax to determine argument structure, and it is the specification of a cluster that interacts with the semantic inference system to determine a semantic label modulo context. This means that a feature specification is associated with multiple interpretations. It was argued that the syntax cannot distinguish between *recipients*, *goals*, *locations*, and *possessors*, as they are associated with the same feature cluster; they are labels that can only be inferred by the semantic inference system. It was also claimed that two identical feature clusters cannot be realised on the same theta grid; they must be unique. With this in mind, the data showed that a *goal/recipient/locative/possessor* could only be associated with the [-c] cluster. The structure of the Theta System means that a thematic hierarchy as usually conceived cannot exist. Instead an alternative hierarchy was given – The Thematic Cluster Hierarchy. It was proposed that this hierarchy

could account for the distribution of arguments. The hierarchy was based on evidence that suggests that positive values were superior to negative values in the sense that they regularly occurred higher in a structure. The discussion then moved onto the syntax of double-complement structures as proposed in Janke and Neeleman (2012). In this account the variants of a dative alternation were identified by distinct and independent syntactic structures – an ascending structure of Chomsky (1981) for the dative construction and a descending structure based on Larson (1988) for the double-object construction. It was shown that Chomsky’s and Larson’s accounts were problematic. Chomsky’s analysis could not account for data that is sensitive to syntactic structure in the double-object construction, and Larson’s analysis could not account for constituency in the dative construction. Janke and Neeleman (2012) proposed that both structures exist independently, and neither is derived from the other. The motivation for the descending structure was as a repair strategy to satisfy Case Adjacency. However, what triggers a structure that is in need of repair in the first place was not discussed. In other words, no account for why the NP2 argument appears in a position that requires the movement of the verb to satisfy Case licensing was proposed. The discussion then moved on to the Construction Grammar account of the spray/load and dative alternations. This account argues that each of the variants from their respective alternations is motivated by distinct meanings. The reason a variant exists is because it describes a specific event that is dissociable from the meaning of the other variant from its alternation. The Construction Grammar approach argued for a holistic approach that treats a construction as a non-compositional whole rather than a structure derived by syntactic rules. It was shown that this account is problematic on many levels. Firstly, the rules that license the fusion of verb roles and construction roles were shown to be inadequate. They could not account for cause-motion constructions that had an inferred instrument subject. The rules were unable to constrain the appearance of inanimate subjects in cause-to-receive constructions, whereas the associated feature cluster could be construed as animate. It was also shown that the stipulation that the argument associated with a constructional recipient must be construed as a willing participant in the event did not generalise beyond specific verbs. It was shown that it is in fact the potential of the argument to physically take ownership which determines a recipient reading. Secondly we saw that the constraints on the compatibility of a verb and a construction were problematic. In the cause-to-receive construction, Goldberg had to resort to pragmatic constraints to account for the polysemy of this construction. Moreover, it was difficult to extract the meaning contributed by the construction from the meaning contributed by the verb. It was argued that the licensing of a verb with a construction was subject to unpredictable idiosyncrasies as data showed that double-object constructions with certain verbs could not be associated with a cause-to-receive meaning. It was also argued that Construction Grammar could not account for why some verbs were licensed to appear with the

constructions in an alternation whilst other verbs with very similar semantics were not. It was argued that the analysis of the *with*-PP in the *with*-variant construction was wrong. The proposal that the *with*-PP is an adjunct did not correspond with the typical behaviour of adjuncts, and the association of the *with*-PP with an *instrument* semantic role did not account for the data. The *with*-PP is also associated with an absence of cause in the event. Such an interpretation had ramifications for the possible cluster associated with this argument. This participant role in the spray/load alternation could only be associated with a [-m] cluster. However, this does not affect the analysis of the structures of the spray/load alternation and the dative alternation because the structure of the Feature Cluster Hierarchy is maintained between the variants whether the NP1 is assigned [-c-m] or [-m]. Construction Grammar also could not account for *with*-variant constructions that allowed the optional expression of the *with*-PP, and *with*-variant constructions that only obligatorily expressed the *with*-PP. It was argued by Goldberg that the optional expression of the *with*-PP was motivated by a Gricean-type maxim of Quantity; no other effect of context is licensed. This led the discussion onto the effects of context on the spray/load and dative alternation. We first introduced the idea that the human processing system is distinguished by its limited processing capacity. This system constrains the way that information is converted into language such that the incremental processing of referents corresponds with the linear order of arguments in a construction. The incremental processing of referents was affected by attention. Attention is itself affected by the presence of contextual features. Focus was given to the egocentric perception of distance, which is a feature untested on the constructions of concern to this thesis. It was hypothesised that this feature influences the word order in the spray/load and dative alternations. This now sets the scene and has provided the necessary background for the rest of the thesis. In the next chapter, I address the first claim of this work; that the structures of the spray/load alternation parallel those of the dative alternation. A range of syntactic tests used in Janke and Neeleman (2012), which are generally accepted as being sensitive to syntactic structure, are applied to the spray/load and dative alternations. This is to determine which structures of the dative alternation in (2.12) correspond with the structures of the locative variant and the *with*-variant constructions.

Chapter 3. Comparing Structures

3.1. Comparing structures from the spray/load alternation with structures from the dative alternation

This chapter compares the structures found in the spray/load alternation with structures found in the dative alternation directly. Throughout this thesis the spray/load alternation has been referred to in parallel with the dative alternation and we will now see what the basis for this is. As each of the sentence types in the dative alternation and the spray/load alternation exhibit a difference in the word order of their arguments, an interesting question that arises is whether there exists a parallelism between the structures across the constructions. In other words, is there evidence for a unified account of their structures? There are some who have proposed a similarity between the alternations at some level (e.g. Speas, 1990; Larson, 1990; 2014), although the analyses have not been accompanied by a systematic application of the tests that can reveal similarities and differences in structure. The contribution that this chapter makes is to move the original claims of Speas (1990) and Larson (1990; 2014) forward by showing that the evidence weighs heavily in favour of the structures of the locative variant construction and the *with*-variant construction being comparable with the dative construction and double-object construction respectively. This proposal differs from previous analyses in two ways. Firstly, it does not assume a derivational analysis of the spray/load alternation (e.g. Speas, 1990; Larson, 1990; 2014), and secondly it is claimed that the *with*-variant construction of the spray/load alternation has a structure which corresponds to that of the double-object construction rather than the structure of the dative construction (e.g. Hale and Keyser, 1995; Damonte, 2005). We start by comparing the locative variant construction with the dative construction.

3.2. Comparing the locative construction with the dative construction

Recall from chapter 2 that in Goldberg (1995) it is claimed that the dative construction and the locative variant construction are instances of the same construction – the cause-motion construction. This is because in both constructions the NP2 argument is introduced by a locative preposition. The dative construction tends to express an event that involves an agent X causing the movement of an object Y toward the location of Z, whereas a locative construction expresses an event that involves an agent X causing in a specified manner the movement of an object Y toward the precise spatial location of Z.

The only difference between a locative variant construction and a dative construction is that the locative variant construction exhibits more flexibility in the kind of preposition it can appear with. These are prepositions that denote a more precise spatial trajectory than the preposition *to* (which is usually associated with a dative construction). I take the view of Hale and Keyser (1996), who claim that it is the extra *manner* element to the verb semantics that licenses a preposition with richer semantics; however, the structures proposed in Hale and Keyser (1996) differ from those argued for here. This semantic distinction between a specified and underspecified manner is not necessarily paralleled by syntactic differences. It would be spurious to attribute the difference between the sentences in (199a) and (199b) to a difference in syntax. As such, it is suggested here that the locative variant construction and the dative construction are characterised by the same ascending syntactic structure: S V NP1 P NP2.

- (199) a. Sam fed the data to the machine.
b. Sam fed the data into the machine.

(Larson, 2014: 214. His 48.)

The Feature Cluster Hierarchy in (2.9) provided evidence for the comparison of the hierarchical structure of the locative variant with the dative construction. Recall that in the dative construction and the locative variant construction the NP2 argument introduced by a preposition is identified with the cluster [-c]. It is underspecified for /m and so inferences of animacy are not ruled out. This argument could not be associated with [-c-m] because the mental state of the participant is relevant to how the event is interpreted and a cluster that is specified for /-m means that the mental state of the participant is irrelevant to the interpretation of the event. This meant that both the dative construction and the locative variant construction must both profile a [-c] cluster as the Theta system did not distinguish between a goal-location and a goal-recipient. However, the cluster assigned to the NP1 argument in the locative variant construction argued for in chapter 2 differs from the cluster assigned to the NP1 in the dative construction. Recall that in the spray/load alternation, the NP1 argument was assigned a [-m] cluster. The NP1 argument in the *with*-variant construction could be inferred as an instrument in certain contexts. This was not a consistent interpretation in all *with*-variant constructions and this was argued to be relevant to the interpretation of the event. Following the assumption that the feature specification of the locative variant construction is the same as the

with-variant construction, then the NP1 participant of the locative variant construction can only be designated a [-m] cluster. In the hierarchy proposed in (54), repeated in (200), there was no hierarchical distinction proposed between [-c] and [-m].

(200) *The Feature Cluster Hierarchy*

[+c +m], [+c]/[+m], [+c -m]/[-c +m], [-c]/[-m], [-c -m]

The distribution of arguments with a subset of *get*-type verbs in (201) suggest that the [-c] tends to occur higher in the structure than [-m]. These are verbs that do not entail that the goal plays a causal role in the getting event. A causal interpretation is blocked by /-c.

- (201) a. Sam_[-c] received a parcel_[-c -m] from Amazon_[-m].
b. Sam_[-c] inherited a portrait_[-c -m] from a relative_[-m].

These verbs are few so further evidence is needed. With verbs of inherently directed motion (Levin, 1993: 51.1), where the direction emits from a source, the cluster typically inferred as a *theme* consistently appears before the cluster inferred to be the *source*. This suggests that the [-m] cluster occurs lower in the hierarchy than [-c-m] as I show in (202).

- (202) a. The convict_[-c -m] escaped from prison_[-m].
b. The parcel_[-c -m] arrived from Paris_[-m]
c. The apple_[-c -m] fell from the tree_[-m]

Conversely, as we see with the dative construction, *goals* tend to occur in structures above *themes*.

- (203) a. John sent the parcel_[-c -m] to Mary_[-c].
- b. Sam handed the keys_[-c -m] to Laura_[-c].

The Feature Hierarchy is adjusted to accommodate this data and the revised hierarchy is proposed in (204). Now the [-m] cluster is the lowest ranked in the hierarchy.

(204) *The Feature Cluster Hierarchy (revised)*

[+c +m], [+c]/[+m], [+c -m]/[-c +m], [-c], [-c -m], [-m]

The consequence of this is that in the locative construction in which the [-c] and [-m] clusters are both profiled, the [-c] must occur higher in the structure than [-m]. There is no evidence to suggest that this analysis of the feature cluster of NP1 in the dative construction requires adjustment from the cluster associated with a typical *theme*. Example (205) shows that the mental state of the NP1 referent is irrelevant to how the event is interpreted.

(205) Sam gave/sent/brought/handed [the baby/ the iphone/ the cheque]_{NP1} to [Bill]_{NP2}.

The NP1 in the dative construction also cannot be construed as an *instrument* so the /c feature cannot be given a positive value or be underspecified. The cluster [-c-m] is therefore the only option. This means that the VP objects of a dative construction have the clusters [-c -m] and [-c]. The Feature Cluster Hierarchy uncontroversially predicts that the [-c] cluster appears in a structure that is higher than [-c-m]. It then seems that the hierarchical relation of the objects in the dative construction VP is mirrored by the hierarchical relation between the objects in the VP of the locative variant construction. As NP1 also appears linearly before NP2 in both the dative construction and the locative construction, their respective structures correspond to the ascending structure of Janke and Neeleman (2012). This is illustrated in (206).

(206) a. The dative construction

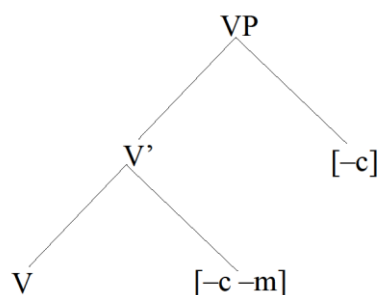

b. The locative variant construction

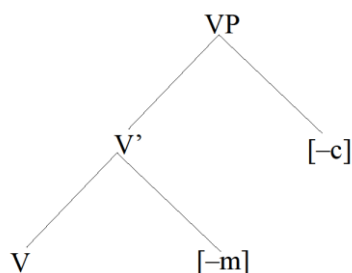

Here is the first point of comparison between the structures of the dative alternation and the structures of the spray/load alternation; the hierarchical structure and linear order of the locative variant construction matches the hierarchical structure and linear order of the dative alternation. Discussion now moves onto to a comparison of the structure of the *with*-variant construction with the structure of the double-object construction.

3.3. Comparing the *with*-variant construction with the double-object construction

As has been claimed throughout this thesis, the thematic specification of a verb involved in an alternation is the same for both of its variants. This means that the double-object construction must be identified by the same hierarchical arrangement of its arguments as the dative construction. This is relatively uncontroversial. As was argued in (2.9), the Feature Cluster Hierarchy is blind to linear order. The only difference between the dative construction and the double-object construction is the linear order of the arguments (abstracting from the appearance of a preposition on the NP2 argument in the dative construction). The descending structure of Janke and Neeleman (2012) provides the correct structure to maintain the hierarchical distinction between [-c -m] and [-c] for the double-object construction. The NP1 is generated in the VP complement position and the NP2 is generated in the VP specifier position. The [-c -m] cluster therefore appears in the structure lower than [-c]. The Feature Cluster Hierarchy is thus maintained and the linear order of arguments is not constrained by the hierarchical structure. This is illustrated again in (207).

(207)

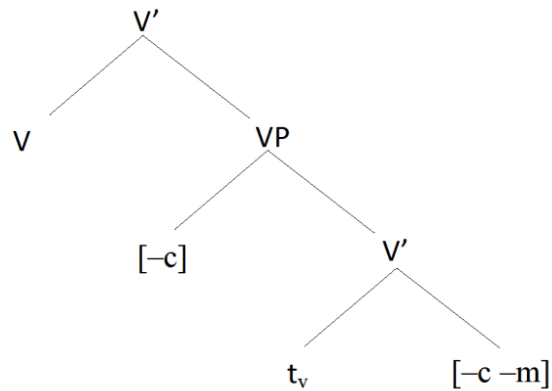

In the case of the *with*-variant construction, the hierarchical structure of the thematic clusters is only maintained in the descending structure of Janke and Neeleman (2012). The NP1 is generated in the VP complement position and the NP2 is generated in the VP specifier position. The [-m] cluster appears lower in the structure than [-c] as illustrated in (208).

(208)

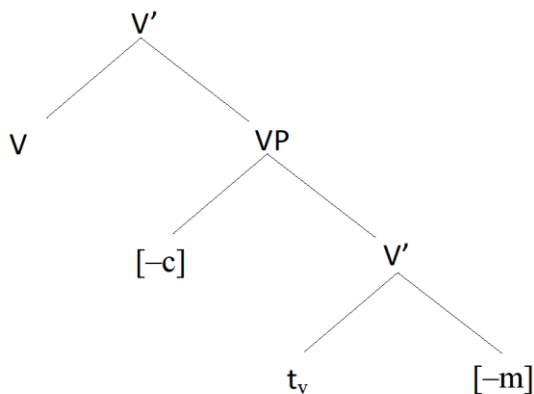

The ascending structure provides the wrong structure. If this were the structure for the *with*-variant construction, the hierarchical relation would be lost, as illustrated in (209).

(209)*

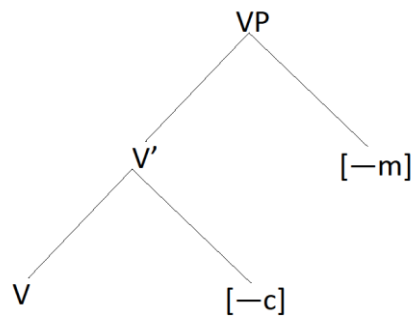

Moreover, *feed* can also appear with a double-object construction as well as a *with*-variant construction as observed by Larson (2014) as I showed in (199). Under the assumption that the verb has a only one theta cluster specification, this provides the second point of comparison between the structures of the dative alternation and the structures of the spray/load alternation; the hierarchical structure and linear order of the *with*-variant construction matches the hierarchical structure and linear order of the double-object construction. In order to strengthen this claim, the rest of this chapter is devoted to a systematic application of tests that are accepted as an indication of a construction's syntactic structure. Based on our analysis of the Theta System and the view of the syntactic structure of Janke and Neeleman (2012), it is predicted that the locative variant construction will behave similarly to the dative construction, and the *with*-variant construction will behave similarly to the double-object construction in respect to the tests. In (3.4), we will see that this prediction is born out in a number of tests: scope interpretation, variable binding, the construction of passives, deriving nominal expressions from VPs, sluicing ellipsis, *do so* anaphora, and the licensing of floating quantifiers. Section (3.5) shows some data that remain unanswered for. This is the case with the formation of unaccusatives, synthetic compounds, the distribution of the adverb *right* with verb-particle constructions, and some aspects of A-bar movement. I will save discussion as to why this occurs for chapter 6.

3.4. Evidence for Parallelism

3.4.1. Scope

3.4.1.1. Quantifier scope

In respect to scope interpretation, double-object constructions have been shown not to allow the NP1 to take scope over NP2 (e.g. Bruening, 2001). For instance, *each doll* in (210a) cannot take scope over *a child*. This means that children do not vary with dolls in this sentence; there must be a single child receiving all of the dolls. This is known as scope freezing (Aoun and Li, 1989) as only one scopally determined reading is possible. Contrastingly, scope relations in the dative construction appear to be free. In (210b), although there is a preferred reading in which each child receives a distinct doll, the alternative reading, in which there is only one doll that is collectively given to the children, is also possible.

- (210) a. I gave a child each doll. $a > each, *each < a$
b. I gave a doll to each child. $a > each, each < a$

(Bruening, 2001:234. His 2.)

This restriction on interpretation has been shown to hold for the *spray/load* alternation (e.g. Lebeaux, 1983; Schneider-Zioga, 1988), as shown in (211). The *with*-variant construction patterns with the double-object construction as there must be one single armchair that is being covered by all of the sheets. However, the direction of the scope relation in the locative variant construction is free, just as was shown in the dative construction. Either the same sheet could have been draped over every single armchair, or there is a unique sheet for every single armchair, which is the preferred reading.

- (211) a. Maud draped an armchair with every sheet. $a > every, *every > a$
b. Maud draped a sheet over every armchair. $a > every, every > a$

For scope interpretation there is typically a default association of scope interpretation and syntactic structure. The c-command domain of an operator coincides with its scope (Janke and Neeleman, 2012). This indicates that the universal operator *every* in (211a) c-commands the existential phrase – *a sheet* – which means that *every* is structurally higher than the existential. This suggests that for both the double-object construction and the *with*-variant construction, NP2 is structurally higher than the direct object. For the dative construction and the locative variant construction, the preferred reading also suggests that NP2 is structurally higher than NP1. On this basis, the structure of the dative construction is distinguished from the structure of the double-object construction, and the structure of the locative variant construction is distinguished from the structure of the *with*-variant construction. Scope interpretation for both the dative and locative constructions suggest that they have a structure where NP2 is structurally higher than and to the right of NP1 – an ascending structure – whereas the scope interpretation in the double-object construction and the *with*-variant construction suggest a structure where NP2 is structurally higher than NP1 and to its left – a descending structure. Now I turn to a phenomenon that is dependent on scope relations; that of pair-list readings. The following section relies heavily on arguments in Bruening (2001).

3.4.1.2. The unavailability of pair-list readings in *wh*-questions

This phenomenon is reliant on which scope relations are possible. A pair-list reading is when the scope relation between a quantifier and a *wh*-word allows a distributive reading (e.g. Moltmann and Szabolcsi, 1994; Bruening, 2001). A pair-list reading arises when a quantifier is in a position where it takes scope over the *wh*-word (May, 1988) or its trace (Aoun and Li, 1989). In (212), there can be a different book given to each different student in (212a), and a different sheet for each different armchair in (212b). This is a pair-list reading as there can be a distinct *book* (or *sheet*) from a set of *books* (or *sheets*) that can be matched to an individual student (or chair) from a set of *students* (or *chairs*). This is a one-to-one mapping of individual books to individual students from a set of books and a set of students, and individual sheets to individual chairs from a set of sheets and a set of chairs. Both the dative (212a) and the locative variant (212b) allow this reading (e.g. Stroik, 1996), whereas the double-object (213a) and *with*-variant (213b) constructions do not (e.g. Bruening, 2001); only a collective reading is available. In (213a) there can be only one book that is given to each of the students, and in (213b) there can be only one armchair that is draped with every single sheet, and in (213b') there is only one wall that is sprayed with multiple colours.

- (212) a. (Which book)_i did you give *t_i* to every student? P-L OK
- b. (Which sheet)_i did he drape *t_i* over every armchair? P-L OK

(Bruening, 2001: 236. His 5.)

- (213) a. (Which student)_i did you give *t_i* every book? *P-L
- b. (Which armchair)_i did he drape *t_i* with every sheet? *P-L
- b'. (Which wall)_i did he spray *t_i* with every colour of paint? *P-L

(Bruening, 2001: 237. His 6.)

What this has shown is that again the *with*-variant construction mirrors the restriction found in the double-object construction, in that the quantifier does not take scope over the *wh*-word. In both the locative and the dative constructions, the quantifier can take scope over the *wh*-word. This is a further example of scope relations that suggests that scope interpretation for both the dative and locative constructions have a structure where NP2 is structurally higher than and to the right of the NP1 – an ascending structure – whereas in the double-object construction and the *with*-variant construction, the data suggest a structure where NP2 is structurally higher than NP1 and to its left – a descending structure. I now turn to another scope dependent phenomenon; the failure of variable binding.

3.4.1.3. Failure of variable binding

Quantifiers can only bind variables that fall within their scope (e.g. Higginbotham 1980; May 1985; Bruening, 2001). In the dative construction, an NP2 that is a universal quantifier is able to bind a variable inside an existential quantifier inside the NP1. We see this in (214a), where the pronoun *her* is bound by the existential NP2 *every professor*, which allows a distributive reading where *every* takes scope over the existential, as well as a collective reading. The distributive reading is not possible in the double-object construction, as shown in (214b), which can only have a collective reading. Just as in pair-list readings, this shows a scope freezing effect. Inverse scope is unavailable in the double-object construction.

- (214) a. Robert sent a student who'd taken her_i course to every professor_i. *every > a*
- b. Mona sent a professor who'd reviewed it_i every book_i. **every > a*

(Bruening, 2001: 238. His 12.)

This pattern is mirrored in the spray/load alternation. In the locative construction, a universal quantifier in the NP2 is able to bind a variable inside an existential quantifier in the NP1 allowing a default distributive reading as well as a collective reading as seen in (215a), but this is not possible in the *with*-variant construction (215b) which only allows a collective reading.

- (215) a. Maud draped a sheet that matched its_i colour over every armchair_i.
every > a
- b. Maud draped an armchair that matched its_i colour with every sheet_i.
**every > a*

(Bruening, 2001: 238. His 13.)

This subsection has shown that scope interpretation in the dative alternation is matched in the spray/load alternation. In this respect, the locative variant construction patterns with the dative construction, and the *with*-variant construction patterns with the double-object construction. I now turn to the formation of passive constructions, where it will be argued that data suggests that the passivisation of a structurally higher object is impossible.

3.4.2. Passive formation

Arguments bearing the indirect object role have relatively free distribution in active sentences, but are subject to several restrictions in passives (Anagnostopoulou, 2003). It is known that the linearly second argument of a double-complement sentence (NP1) cannot passivise (e.g. Perlmutter and

Postal, 1983). A passive, as in (216b) is derived by withdrawing the accusative case feature of a grammatical object that is licensed by the verb. The subject theta feature is suppressed, which then triggers movement of the object to subject position. The suppressed subject can then optionally appear as an adjunct to the VP (see Burzio, 1986).

- (216) a. John kissed Jane_{ACC}.
b. Jane was kissed (by John).

In the dative construction, the indirect object cannot become the subject of a passive construction as it has a dative case feature which is not licensed by the verb (217b), even if we separate the NP from its preposition, leaving the preposition stranded (217b'). The NP1 can passivise (217a) because this case feature is withdrawn. In a double-object construction, the NP1 cannot become the subject of a passive sentence (218a) but the NP2 can (218b). The NP2 of the double-object construction is the highest accusative marked object in the construction, so it can have this feature withdrawn, triggering movement. The NP1 is blocked from movement by the higher accusative marked NP2.

- (217) I sent (a letter_{ACC}) (to Pat_{DAT}).
- a. A letter was sent to Pat_{DAT} (by me).
b. *To Pat_{DAT} was sent a letter_{ACC} (by me).
b'. *Pat was sent a letter_{ACC} to (by me).

- (218) I sent Pat_{ACC1} a letter_{ACC2}.
- a. *A letter_{ACC2} was sent pat_{ACC1} (by me).
b. Pat_{ACC1} was sent a letter_{ACC2} (by me).

This asymmetry is mirrored by the spray/load alternation. The locative variant construction patterns with the dative construction as the NP1 is the only argument that can passivise as illustrated in (219) and (220). This indicates that the NP1 has accusative case that is licensed by the verb. The *with*-variant construction patterns with the double-object construction in that only the NP2 can become the subject of a passive construction as I show in (221) and (222).

(219) I loaded the hay onto the wagon.

- a. The hay was loaded onto the wagon (by me).
- a'. *Onto the wagon was loaded the hay (by me).
- b. *The wagon was loaded the hay onto (by me).

(220) I sprayed paint on the wall.

- a. Paint was sprayed on the wall (by me).
- b. *Onto the wall was sprayed paint (by me).
- b'. *The wall was sprayed paint on (by me).

(221) I loaded the wagon with hay.

- a. The wagon was loaded with hay (by me).
- b. *with hay was loaded the wagon (by me).
- c. *hay was loaded the wagon with (by me).

- (222) I sprayed the wall with paint.
- a. The wall was sprayed with paint (by me).
 - b. *With paint was sprayed the wall (by me).
 - b'. *Paint was sprayed the wall with (by me).

In this section, we have seen that the asymmetry that exists between the constructions in the dative alternation is replicated in the spray/load alternation. If passivisation is restricted by structure such that one argument is blocked from becoming the subject of a passive sentence because it is structurally lower in the tree than the other, then this is another example of the structural similarity between the complements of the verbs in these alternations. I now turn to data on deverbal nominalisations, where we will see that the locative variant and dative construction only allow the NP1 to become part of a derived deverbal nominal, whereas the double- object construction and *with*-variant construction do not allow either object to become part of a deverbal nominal.

3.4.3. Deverbal nominalisations

A deverbal nominalisation is a category-changing operation in which a noun has been derived from a verb and its object. With certain restrictions, deverbal nominalisations allow the object of a verb to surface either as the genitive of the resulting NP or surface inside an *of*-phrase (see Grimshaw, 1990; Beck and Johnson, 2004). This is demonstrated in (223), where the complement of the verb *examine* can become part of the deverbal nominal inside an *of*-phrase, as in (223a), or as the genitive of the resulting NP, as in (223b). According to Kayne (1984c), this is only possible if the object is a 'logical object' of the verb as (224) shows. This means that only when the verb and object form a constituent can the object become part of a deverbal nominal. The verb *believe* takes the whole clause as its complement, not the NP *John*, which prevents the NP from becoming part of the deverbal nominal.

(223) Examine the problem

- a. The examination of the problem.
- b. The problem's examination.

(224) Believe John to be happy

- a. *The belief of John to be happy.
- b. *John's belief to be happy.

(adapted from Beck and Johnson, 2004: 98)

For a dative construction, the direct object follows the pattern of the object of *examine*, and not of *believe*. *The ball* can become part of the deverbal nominal inside an *of*-phrase, as in (225a), or as the genitive of the resulting NP, as in (225a'). However, the indirect object cannot become part of the deverbal nominal as illustrated in (225b) and (225b'). This indicates that it is 'the ball' and the verb that form a constituent.

(225) Present the ball to Satoshi

- a. The presentation of the ball to Satoshi.
- a'. The ball's presentation to Satoshi.

(Beck and Johnson, 2004: 99. Their 6.)

- b. *The presentation of Satoshi of the ball.
- b'. *Satoshi's presentation of the ball.

Examples (226) and (227) demonstrate that the locative variant follows this pattern; the NP1 can become part of the deverbal nominal either inside an *of*-phrase, as in (226a) or (227a), or as the genitive of the resulting NP, as in (226a') and (227a'). This suggests that verb *load* and 'the hay' form a constituent in (226), as does the verb *spray* and 'the paint' in (227). The example in (226b) and (227b) show that the same is not true for NP2.

- (226) Load the hay onto the wagon.
- a. The loading of the hay onto the wagon.
 - a'. The hay's loading onto the wagon.
 - b. *The loading of the wagon of the hay.
 - b'. *The wagon's loading of the hay.

- (227) Spray the paint on the wall.
- a. The spraying of the paint on the wall.
 - a'. The paint's spraying of the wall.
 - b. *The spraying of the wall of the paint.
 - b'. *The wall's spraying of the paint.

In a double-object construction neither object can form part of the deverbal nominal⁵². In (228), the (a) examples show the inability of NP2 to be part of this structure. The (b) examples show that the NP1 cannot become part of a deverbal nominal structure.

⁵² Kayne (1984c) uses this evidence to propose that the immediate post VP NP2 in the double-object construction is a specifier of a small clause of which NP1 is a complement.

(i) [VP[V [XP [NP X'[X NP]]]]]

(228) Present Satoshi the ball.

- a. *The presentation of Satoshi of the ball.
- a'. *Satoshi's presentation of the ball.
- b. *The presentation of the ball of Satoshi.
- b'. *The ball's presentation of Satoshi.

In (229) and (230) the *with*-variant construction patterns exactly with the double-object construction as neither object can surface in a deverbal nominal structure. Again the (a) examples show the inability of the NP2 to be part of this structure. The (b) examples demonstrate that the NP1 also cannot become part of a deverbal nominal structure.

(229) Load the wagon with the hay.

- a. *The loading of the wagon with the hay.
- a'. *The wagon's loading with the hay.
- b. *The loading of the hay of the wagon.
- b'. *The hay's loading of the wagon.

(230) Spray the wall with the paint.

- a. *The spraying of the wall with the paint.
- a'. *The wall's spraying with the paint.
- b. *The spraying of the paint of the wall.
- b'. *The paint's spraying of the wall.

The data in this section indicate that the first NP of the double-object and *with*-variant construction has a different syntactic status to the first NP of the dative and locative variant constructions. In the dative and locative constructions, the NP1 and verb form a constituent, whereas the NP2 does not. In the double-object and *with*-variant constructions, neither object form a constituent with the verb. This evidence may not prove that the NP2 recipient in a dative sentence and the locative NP2 of a locative variant sentence are the same as they may be restricted from deverbal nominalisations for independent reasons. However, it does suggest that the NP1 of the dative and locative variant constructions behave similarly in terms of being excluded from this restriction. The next section will present data on ellipsis phenomena.

3.4.4. Ellipsis

In this section I review the behaviour of the dative and spray/load alternation in two types of elliptical phenomena: sluicing and *do so* substitution. The main claim here is that if an element of the construction is found in the antecedent phrase, then the same element must occur in the elided phrase (e.g. Merchant, 2013). The dative alternation and the spray/load pattern in the same way for these types of ellipsis.

3.4.4.1. Sluicing

Sluicing is an elliptical construction in which a sentential portion of a constituent question is elided, leaving a *wh*-remnant (Merchant, 2003), as in (231).

(231) Jack bought something, but I don't know what (Jack bought).

(Merchant, 2003: 1. His 1a.)

In (231), the *wh*-phrase is left stranded and the elided structure has an overt antecedent in a preceding clause. The antecedent has the same structure as the elided material. The interpretation of the *wh*-phrase is that of a *wh*-phrase plus the elided material (Ross 1969), which implies that it is in some way still present (as indicated by the material in parentheses). It is understood that the elided material is

still present at some level of syntactic structure, even though it is phonetically null. It should be noted that when a *wh*-phrase corresponds with a PP then two options are available: the *wh*-word can appear with or without the preposition as shown in (232a) and (232b) respectively.

- (232) a. Jack baked a cake for someone but I don't know for who (Jack baked a cake).
b. Jack baked a cake for someone but I don't know who (Jack baked a cake for).

Both the dative and double-object construction allow sluicing of the verb and either NP1 ((233a) and (233b) respectively) or NP2 ((233a') and (233b') respectively) which suggests that both the verb and NP1, and the verb and NP2 can form a constituent in both structures. The NP2 in the dative construction can appear with or without the preposition as shown in (233a').

- (233) a. John gave something to Mary but I don't know what (John gave to Mary).
a'. John gave a pen to somebody but I don't know to whom/who (John gave a pen).
b. John gave Mary something but I don't know what (John gave Mary).
b'. John gave someone a pen but I don't know who (John gave a pen).

The *spray/load* alternation is also not subject to any restriction on the sluicing of an object argument. The locative variant and *with*-variant constructions allow the sluicing of the NP1 ((234a) and (234b) respectively). In the *with*-variant construction, the *wh*-word NP1 can appear with or without the preposition (234b). Both structures also allow sluicing of the NP2 ((234a') and (234b') respectively). In the locative variant construction, the *wh*-word NP2 can appear with or without the preposition, as shown in (234a'). This is also shown for the verb *spray* in (235). These data suggest that the verb and NP1 are a constituent, as well as the verb and NP2.

- (234) a. John loaded something onto the truck but I don't know what (John loaded onto the truck).
- a'. John loaded the boxes onto something but I don't know what (John loaded the boxes onto).
- b. John loaded the truck with something but I don't know what (John loaded the truck with).
- b'. John loaded something with boxes but I don't know what (John loaded with boxes).
- (235) a. John sprayed something on the wall, but I don't know what (John sprayed on the wall).
- a'. John sprayed paint on something but I don't know what (John sprayed paint on).
- b. John sprayed the wall with something but I don't know what (John sprayed the wall with).
- b'. John sprayed something with paint but I don't know what (John sprayed with paint).

Sluicing structures can also appear in constructions where more than one *wh*-phrase can form remnants of sluicing, as in (236). This is termed multiple sluicing.

- (236) ?Everyone brought something, but I couldn't tell you who what.

(Merchant, 2003: 13. His 50.)

Even though multiple sluicing has marginal acceptability for some speakers, when the *wh*-words correspond to the two objects in a dative alternation sentence, interestingly they are much less acceptable in a double-object construction (237a) than a dative construction (237b)⁵³.

⁵³ As pointed out by Merchant and Simpson (2012), Richards (1997) notes that multiple sluicing of the double-object construction becomes more acceptable if a conjunct separates the two *wh*-words.

(i) John gave someone something, and I want to know who and what.

- (237) a. *John gave someone something and I want to know [who what].
b. John gave something to someone but I don't know [what to whom].

(Merchant and Simpson, 2012: 86. Their 8.)

This restriction in multiple sluiced constructions in the dative alternation is mirrored by the constructions in the spray/load alternation which I show in (238), where two *wh*-words in the locative variant construction is acceptable (238b). Multiple sluicing in the *with*-variant construction is marginally acceptable (238a).

- (238) a. John loaded somebody onto something but I don't know who onto what.
(*e.g. a passenger onto a plane*)
b. ??John loaded somebody with something but I don't know who with what.
(*e.g. a workman with tools to carry*)

The presence of the preposition between the *wh*-words helps with the acceptability of the sentences in (238), although the reading is still difficult in the *with*-variant construction in (238b). This is the case even though a preposition intervenes between the two object arguments. This suggests that something other than the presence of material intervening between the two *wh*-words licenses the construction. As constructions containing multiple *wh*-words can give rise to Superiority effects when one of the *wh*-words is fronted⁵⁴, as shown for the dative alternation in (239) and (240), it is possible that the hierarchical structure of the VP also restricts multiple sluicing in the *with*-variant construction.

⁵⁴ Recall from (2.11.1) that a Superiority effect is when given a sentence with two *wh*-phrases, only the structurally higher one can move to the left of the clause (e.g. Chomsky, 1973).

- (239) a. *You gave which book to whom?*
 b. (Which book)_i did you give t_i to whom?
 b'. *(To whom) did you give which book t_i?

- (240) a. *You gave who which book?*
 b. Who did you give t_i which book?
 b'. *(Which book)_i did you give who t_i?

(Barss and Lasnik, 1986: 349. Their 11.)

These data are interesting for accounts of ellipsis in general, but I will not pursue this further here. I now turn attention to the behaviour of the constructions with *do so* anaphora.

3.4.4.2. *Do so* anaphora

Do so anaphora is a form of ellipsis, where the VP-proform can be coreferenced with a verb and its complements, as in (241a), as well both adjacent ((241b) and (241c)) and non-adjacent adjunct material (241e) (see Lakoff and Ross, 1976; Culicover and Jackendoff, 2005). However, *do so* cannot be coreferenced with a transitive verb without its complement, as seen in (241d). The coreference in the examples is indicated by subscripts.

- (241) a. I [ate an apple]_i yesterday in the park, and Moira [did so]_i today in the garden.
 b. I [ate an apple yesterday in the park]_i, and Moira [did so]_i too.
 c. I [ate an apple yesterday]_i in the park, and Moira [did so]_i in the garden.

- d. * I [ate]_i an apple yesterday in the park, and Moira [did so]_i an orange today in the garden.

(Lakoff and Ross, 1976. Cited in Houser, 2010: 2. His 3.)

- e. ? I [ate an apple]_i yesterday [in the park]_j, and Moira [did so]_{i+j} today.

(Culicover and Jackendoff, 2005. Cited in Houser, 2010: 2. His 5.)

What this shows is that *do so* substitution is sensitive to the constituency of the VP precluding omission or replacement of the moved verb and the postverbal DP in a VP shell structure as pointed out in Janke and Neeleman (2012: 157). If the VP has an object then *do so* will replace the entire VP.

In the dative construction, it is possible for *do so* to be coreferenced with the verb and the NP1 as in (242a) or the whole VP as in (242b), but not the verb and PP string as in (242c), suggesting that the verb and NP1 can form a constituent, excluding NP2. The coreference in the examples is indicated by subscripts.

- (242) a. If he [read a sonnet]_i to anyone famous, he [did so]_i to Salman Rushdie.

(Janke and Neeleman, 2012: 157. Their 14a.)

- b. Yesterday, John [read a sonnet to Salman Rushdie]_i, and he [did so]_i today, too.
 c. *If he [read]_i anything to [Salman Rushdie]_i, he [did so]_i a sonnet.

The locative variant construction mirrors this pattern, which I show in (243) and (244). *Do so* can be coreferenced with the verb and the NP1 illustrated in (243a) and (244a) or the whole VP as shown in (243b) and (244b), but not the verb and PP string as I show in (243c) and (244c). The coreference in the examples is indicated by subscripts.

- (243) a. If John [stacked the books]_i onto anything he [did so]_i onto shelves.
 b. The librarian [stacked books onto shelves]_i yesterday, and John [did so]_i today, too.
 c. *If John [stacked]_i anything [onto shelves]_i he [did so]_i the books.

- (244) a. If John [sprayed the paint]_i on anything he [did so]_i on the wall.
 b. Bill [stacked books onto shelves]_i yesterday, and John [did so]_i today, too.
 c. *If John [sprayed]_i anything [on the wall]_i he [did so]_i the paint.

In the double-object construction, it is not possible to reference *do so* either with the verb and NP2 (245a), or the verb and NP1 (245b). It is however possible to replace the whole VP (245c).

- (245) a. *If Bill [gave Mary]_i anything, he [did so]_i a woollen scarf.

(Janke and Neeleman, 2012: 158. Their 13a.)

- b. *If Bill [gave]_i anyone [the book]_i he [did so]_i Mary.
 c. Bill [gave Mary the book]_i today and John [did so]_i yesterday, too.

The *with*-variant construction patterns with the double-object construction in this respect, as illustrated in (246) and (247). It is not possible to reference *do so* with either the verb and NP2 as shown in (246a) and (247a), or the verb and NP1 as in (246b) and (247b), but only the whole VP (246c) and (247c).

- (246) a. *If John [stacked the shelves]_i with anything he [did so]_i the books.
 b. *If John [stacked]_i anything [with books]_i he [did so]_i the shelves.
 c. Bill [stacked the shelves with books]_i today and John [did so]_i yesterday, too.

- (247) a. *If John [sprayed the wall]_i with anything he [did so]_i the paint.
 b. *If John [sprayed]_i anything [with the paint]_i he [did so]_i the wall.
 c. Bill [sprayed the wall with paint]_i today and John [did so]_i yesterday, too.

I have presented in this subsection data that shows that the dative alternation and the spray/load alternation pattern together in two types of elliptical constructions; sluicing and *do so* anaphora. The locative variant construction mirrors the dative construction, and the *with*-variant construction patterns with the double-object construction. The data suggest that the verb and NP1 can form a constituent in the dative and locative variant constructions, excluding the NP2. It also suggests that only the verb and both objects can form a constituent in the double-object and *with*-variant constructions. I now turn the discussion to the behaviour of floating quantifiers in the dative and spray/load alternations.

3.4.5. Floating quantifiers

A floating quantifier (FQ hereafter) is an instance of a quantifier appearing separated from its quantified argument (Bobaljik, 2003). A sentence that exhibits this separation of argument and quantifier, as in (248b), is a paraphrase of a sentence, where the quantifier is not separated from its argument, as in (248a) (e.g. Kayne, 1969, 1975). The quantifier is called *floating* as early proposals took the quantifier to be floating rightward away from its argument (Maling, 1976).

- (248) a. All the students have finished the assignment.
 b. The students have all finished the assignment.

(Bobaljik, 2003: 129. His 45.)

An FQ is licensed to modify the NP1 of the dative construction in (249a) as can be seen in the non-floating example in (249a'). However, the FQ is not licensed for the NP2 as can be seen in (249b). In a double-object construction, an FQ is not licensed for the NP1 (250a), although non-floating

quantification of the NP2 is possible (250b). The inclusion of the quantifier *some* in (250b) shows that *all* is an FQ of NP2 and not a modifier of NP1.

- (249) a. Mary gave the candy all to the kids.
a'. Mary gave all the candy to the kids.
b. *Mary gave candy to the kids all.
b'. Mary gave candy to all the kids.

- (250) a. *Mary gave the kids the candy all.
a'. Mary gave the kids all the candy.
b. Mary gave the kids all some candy.
b'. Mary gave all the kids some candy.

(adapted from Bošković, 2004: 711. His 74.)

The locative variant construction follows the pattern of the dative construction. An FQ is licensed for the NP1, as illustrated in (251a) and (252a), but not the indirect object (251b) and (252b), even though quantification is possible for both arguments.

- (251) a. Sam loaded the boxes all into the lorry.
a'. Sam loaded all the books into the lorry.
b. *Sam loaded the boxes into the lorries all.
b'. Sam loaded the boxes into all the lorries.

- (252) a. Sam sprayed the colours all onto the walls.
 a'. Sam sprayed all the colours onto the walls.
 b. *Sam sprayed the paint onto the walls all.
 b'. Sam sprayed the paint onto all the walls.

The *with*-variant construction follows the pattern of the double-object construction as demonstrated in (253) and (254). An FQ can quantify the NP2 as in (253a) and (254a), but not the NP1 as seen in (253b) and (254b).

- (253) a. Sam loaded the trucks all with the boxes.
 a'. Sam loaded all the trucks with the boxes.
 b. *Sam loaded the trucks with the boxes all.
 b'. Sam loaded the trucks with all the boxes.

- (254) a. Sam sprayed the walls all with the paint.
 a'. Sam sprayed all the walls with the paint.
 b. *Sam sprayed the wall with the colours all.
 b'. Sam sprayed the wall with all the colours.

Lastly, as we saw in section (2.12), Janke and Neeleman (2012) used the presence of an FQ linked to the NP2 in a double-object construction as a test for a descending structure, in which case this is further evidence to suggest that the *with*-variant construction has a descending structure, since an FQ is licensed for the NP2. This section has shown that with respect to FQs, constructions in the spray/load alternation pattern exactly with the constructions in the dative alternation; the locative

variant construction with the dative construction, and the *with*-variant construction with the double-object construction.

In (3.4) I have shown that many phenomena that are used to reveal syntactic structure have a similar distribution in dative and locative variant constructions, and also show similarity between the double-object and *with*-variant constructions. These patterns of acceptability distinguish a dative construction from a double-object construction, and also distinguish a locative variant construction from a *with*-variant construction. It should be noted before concluding this section that an obvious difference between the double-object construction and the *with*-variant construction is the presence in the latter of the preposition *with* and the former having a bare NP⁵⁵. As pointed out in Hale and Keyser (1996), *spray/load* verbs may differ from dative verbs in that they encode a manner component into their argument structure which is realised with a *with*-PP in the *with*-variant construction, and by a variety of prepositions in the locative variant construction (e.g. *on, onto, into*). As was shown in (199) verbs in the dative class of Levin (1993) such as *feed* can appear with prepositions other than *to* in the dative. They can also appear with *with* in the double-object construction in specific contexts. (255a) appears to differ from (255b) in that the latter seems to encode a richer semantics that specifies the particular type of feeding that is taking place – *data feeding*.

- (255) a. John fed the machine the data.
b. John fed the machine with data.

(Larson, 2014: 214. His 48.)

⁵⁵ As pointed out by Larson (1990), dative alternations with *supply* and *provide* also require a preposition and do not allow for a bare outer NP (i), and for many speakers dative alternations with *award* seem to allow either structure (ii):

- (i)
a. The teacher supplied one pencil to every student.
a'. The teacher supplied one student *(with) every pencil.
b. The teacher provided one pencil to every student. The teacher provided one student *(with) every pencil.
- (ii)
a. We awarded one prize to every contestant.
b. We awarded one contestant (with) every prize.

The data that have been presented in this section are standardly used in the literature as tests to probe syntactic structure. The way that the locative variant construction tends to pattern with the dative construction, and the *with*-variant patterns with the double-object construction lends considerable weight to the claim that the constructions in the dative alternation and the constructions in the spray/load alternation are more similar than many have previously considered. However this is not without its problems. In (3.5), I review data which may be problematic for my hypothesis that the constructions in the spray/load alternation can be mapped onto those of the dative alternation. In (3.5.1) I begin with the formation of unaccusative sentences from the constructions of the dative alternation and spray/load alternation.

3.5 Evidence against parallelism

This section sets out a range of data that remains problematic for the analysis in this thesis. Although much of the data does not provide dispute on the structure of the locative construction being parallel to that of the dative construction, it does however raise the question whether one can analyse the *with*-variant construction as having the same structure as the double-object construction. This discrepancy is not viewed as being a fundamental problem because, as we shall see, much of the data presented here which contradicts the proposal in this thesis is itself problematic and remains unresolved in the literature. Much of the problematic data revolves around whether and to what extent referring expressions are moved to different parts of a structure. A rigorous appraisal of the literature for these phenomena would take us too far afield from the task at hand. However, it is recognised that these data remain problematic and require further investigation beyond the scope of this thesis. Some preliminary inroads in accounting for this data are discussed in chapter 6. We begin our presentation of problematic data with the formation of unaccusative sentences.

3.5.1. Unaccusative sentences

Many verbs in English can be used either transitively or intransitively according to the pattern in (256).

- (256) a. The enemy sank the ship.
b. The ship sank.

Baker (1996) claims that only the argument designated as a *theme* in a dative construction can become the subject of an unaccusative structure but the argument designated as a *goal* cannot. To maintain the distinction of NP1 and NP2, the reformulation of Baker's claim is that the NP1 of a dative construction can become the subject of an unaccusative sentence but the NP2 cannot.⁵⁶ Some dative verbs that alternate do follow this pattern for the dative construction given in Baker (1996) as can be seen for the verbs *sell* and *bounce* in (257) and (258) respectively. (257a) and (258a) show that the NP1 of a dative construction can become the subject of an unaccusative sentence, whereas NP2 cannot as shown in (257b) and (258b). In a double-object construction neither the NP1 nor the NP2 can become the subject of an unaccusative sentence as can be seen in (259) and (260).

(257) John sold the car to Tom.

- a. The car sold to Tom.
- b. *Tom sold the car.

(Based on a reading where Tom is the person who bought the car.)

⁵⁶ To highlight his point Baker (1997) uses an example from Wasow (1977) shown in (i).

- (i) a. They dropped the rope (down) to John.
- a'. The rope dropped (down) to John.
- a''. *John dropped (down) the rope. *(based on a reading where John is the receiver of the rope.)*
- b. They dropped John (down) the rope.
- b'. *The rope dropped (down) John.
- b''. *John dropped t (down) the rope.

(Wasow, 1977: 332)

The use of the verb *drop* as a canonical dative alternating verb is problematic as an alternation with *drop* is subject to considerable variation in acceptance (cf. ?They dropped John the rope). This problem is indicated in the verb classification in Levin (1993) who does not include it in her list of alternating verbs. This class of verbs – *verbs of putting in a specified direction*– is marked as a non alternating verb class (1993:47). Also notice the degradation when rope is replaced by other NPs (??They dropped the plate/the wallet/the glass to John.)

(258) Bill bounced the ball to Ben.

- a. The ball bounced to Ben.
- b. *Ben bounced the ball.

(Based on a reading where Ben is the person who the ball is bounced to.)

(259) John sold Tom the car.

- a. *The car sold Tom.
- b. *Tom sold the car.

(Based on a reading where Tom is the person who bought the car.)

(260) Bill bounced Ben the Ball.

- a. *The ball bounced Ben.
- b. *Ben bounced the ball.

(Based on a reading where Ben is the person who the ball is bounced to.)

However, this is not the case for all alternating verbs in the dative class. For the verb *feed*, the NP1 in the dative construction cannot become the subject of an unaccusative sentence as illustrated in (261a) and neither can the NP2 (261b). In the double-object construction, the NP1 can become the subject of an unaccusative (262a), which is still not possible for NP2 (262b).

(261) Sarah fed the pizza to the children.

- a. *The pizza fed to the children.
- b. *The children fed the pizza.

(262) Sarah fed the children the pizza.

- a. The pizza fed the children.
- b. *The children fed the pizza.

In the spray/load alternation, the locative variant construction in (263) does pattern with the dative constructions in (257) and (258) in that NP1 can become the subject of an unaccusative sentence but NP2 cannot.

(263) John sprayed the paint onto the wall.

- a. The paint sprayed onto the wall.
- b. *The wall sprayed the paint.

However the *with*-variant construction in (264) patterns with the double-object construction of *feed* in (262), but not those of *sell* or *bounce* in (259) and (260) as it does allow the NP1 to become the subject of an unaccusative sentence. We can also do this with other spray/load verbs as shown in (265).

(264) John packed the boxes with hay.

- a. *The boxes packed with hay.
- b. Hay packed the boxes.

- (265)
- a. John loaded the trucks with boxes. → Boxes loaded the truck.
 - b. John sprayed the wall with paint → Paint sprayed the wall.
 - c. John wrapped the presents with ribbon → Ribbon wrapped the presents.
 - d. John stuck the paper with glue → Glue stuck the paper.

Baker (1996) claims that neither argument in a locative alternation (in which he includes the spray-load alternation) can become the subject of an unaccusative sentence. However, he only provides data with the verb *swarm* (266) which is neither a ditransitive verb, nor is it from the spray/load class (cf. Levin, 1993, and figure 1 above).

- (266) a. The bees swarmed in the garden.
b. The garden swarmed with bees.

(Baker, 1996: 19. His 43.)

The data in this section suggests that in terms of unaccusativity, the dative alternation cannot be compared to the spray/load alternation as they have different patterns of what can become the subject of an unaccusative sentence. However, what this data also suggests is that unaccusativity does not pattern uniformly for verbs that are argued to belong to the same class. As such, the data for unaccusativity cannot be taken as a strong argument against the parallelism of the spray/load and dative alternation. If we accept that the verb classes laid out in Levin (1993) are correct, then these data remain inconclusive.

I now present data from synthetic compounds, which show very different results for the NP2 complements of dative and spray/load verbs.

3.5.2. Synthetic compounds

Synthetic (a.k.a. verbal) compounds have played a major role in the development of linguistic theory since they raise a number of questions concerning the morphology-syntax interface. Baker (1996) notes that the NP2 of dative-alternation verbs can never become the non-head of a synthetic compound, as exemplified in (267b) and (268b), whereas the NP1 can⁵⁷.

⁵⁷ However, I have found that this is possible with certain verbs. A Google web search uncovered: Animal-feeding (<http://www.epa.gov/agriculture/anafoidx.html>) Student-teaching (http://en.wikipedia.org/wiki/Student_teaching)

(267) John tells secrets to spies.

- a. secret-telling
- b. *spy-telling

(268) John reads books to children.

- a. book-reading
- b. *children-reading

(Baker, 1996: 17. His 35.)

Moreover, the NP2 cannot become the complement of *of* in a derived *-ing* nominal, whereas NP1 can (269).

- (269) a. the telling of secrets, *the telling of spies
- b. the reading of books, *the reading of children

In the spray/load alternation, both the NP1 and NP2 can become the non-head of a synthetic compound (270) and (271), although the kind of event that they describe is markedly different.

(270) Jethro loads hay onto trucks.

- a. hay-loading
- b. truck-loading

(271) Steve packed the glassware into the box.

- a. glassware-packing
- b. box-packing

(based on Baker, 1996: 17. His 34a and 34b.)

NP2 and NP1 can also become the complement of *of* in a derived *-ing* nominal (272).

- (272) a. The loading of hay, the loading of trucks
- b. The packing of glassware, the packing of boxes

In general it would seem that synthetic compounds pattern differently in respect to spray/load verbs and dative verbs. Spray/load verbs have far more flexibility to form synthetic compounds with their arguments than dative verbs, even though the incorporating of an NP2 argument non-head into a compound is possible on occasion. I now address the distribution of the adverb *right* with the particle of a ditransitive particle verb. I show that this data do not indicate a similarity between the double-object and *with*-variant constructions.

3.5.3. *Right* and verb particles

As shown in den Dikken (1995) and Janke and Neeleman (2012) the adverb *right* can modify the preposition particle of a particle verb but only in highly restrictive contexts. *Right* can only modify the particle in a dative construction when NP1 intervenes between the verb and the modified particle as can be seen in (273). The modification of the particle with *right* is not possible at all in a double-object construction, as shown in (274).

- (273) a. *John sent right off a schedule to the stockholders.
 b. John sent a schedule right off to the stockholders.
 c. *John sent a schedule to the stock holders right off.
- (274) a. *John sent the stockholders right off a schedule.
 b. *John sent right off the stockholders a schedule.
 c. *John sent the stockholders a schedule right off.

(Janke and Neeleman, 2012: 171. Their 68 and 69.)

In the spray/load alternation, particles are generally limited to the *with*-variant construction and tend to appear with the completive particle *up* as noted by Fraser (1971)⁵⁸. However, for the limited set that does allow a particle verb construction in the locative variant, *right* can only modify the particle when NP1 intervenes between the verb and the modified particle as seen in (275).

- (275) a. *He loaded right up the goods onto the wagon.
 b. He loaded the goods right up onto the wagon.
 c. ??He loaded the goods onto the wagon right up

However, in contrast to the double-object construction, *right* can modify the particle in a *with*-variant construction which I show in (276). This is acceptable only when NP2 intervenes between the verb

⁵⁸ I disagree with many of the judgements given in Fraser (1971) as do my informants. I only include those that have been independently judged as grammatical. For example, Fraser (1971: 607) includes the following as grammatical:

- (i) *They splattered up the floor with water.
 (ii) *She marked up the tree trunk with her name.

But rejects:

- (iii) He loaded up the goods onto the wagon.

and modified particle (276b). Also, the NP1 cannot intervene between the verb and modified particle (276c).

- (276) Peter loaded up the wagon with the goods.
- a. *Peter loaded right up the wagon with the goods.
 - b. Peter loaded the wagon right up with the goods.
 - c. ??Peter loaded the wagon with the goods right up.

The double-object construction does not pattern with the *with*-variant construction in respect to this data. The dative and locative variant constructions do pattern together as they allow the modification of the particle only when NP1 intervenes between the verb and the particle. I now show further evidence against my proposal. Phenomena attributed to A-bar movement yield a mixed result when comparing the constructions of the spray/load alternation with constructions of the dative alternation.

3.5.4. A-bar movement

An A-bar position is a syntactic position that is not occupied by an argument. It is a position that can be a landing site of movement such as *wh*-movement. In *wh*-movement, the A-bar landing site for the *wh*-phrase is the specifier of the Complementiser Phrase (CP). This node in the structure can accommodate an argument as in *which car* in (277a) or an adjunct as in *how* in (277b) in an interrogative construction. (A-bar movement is a movement operation that moves an argument or adjunct to an A-bar position).

- (277) a. [CP [_{spec-CP} Which car] did] John buy?
- b. [CP [_{spec-CP} How] did] John pick the car?

Many phenomena are said to involve A-bar movement. For the current purpose I present data from short and long *wh*-movement, *tough* movement, and relativisation with a view to illustrating that these tests (which are also used to indicate the structure of the VP) do not support the hypothesis of parallelism between the structures in the spray/load alternation with the structures in the dative alternation. I begin with *wh*-movement.

3.5.4.1. Wh-movement

This is a type of movement operation in which a *wh*-expression is moved to the front of a particular structure. For example, in (277a) above, the *wh*-expression *which car* is said to have moved from its underlying position following the verb to the front of the sentence in order to form the interrogative construction. In English this also involves the movement of an auxiliary to the head of CP. In the dative construction it is possible for either object argument to be in the spec-CP position, as in (278). For many speakers there is a mixed acceptability as to whether the preposition of the NP2 can be left stranded (278b) or pied-piped with the NP (278b').

- (278) Carol gave a cake to the children.
- a. What did Carol give to the children?
 - b. Who did Carol give a cake to?
 - b'. To who(m) did Carol give a cake?

The locative variant construction mirrors the dative construction in allowing both arguments to appear as a *wh*-word in an interrogative construction, which I show in (279). There is also speaker variation in that many speakers do not allow the preposition to be stranded (279b) but require it to be pied-piped with the NP (279b').

(279) John loaded the boxes onto the truck.

- a. What did John load onto the truck?
- b. What did John load the boxes onto?
- b'. Onto what did John load the boxes?

In the double-object construction, it is possible for the NP1 to be the moved *wh*-word in an interrogative (280a), but for many speakers *wh*-movement of NP2 is impossible or degraded (Horsnstein and Weinberg, 1981), as in (280b). When the *wh*-movement is over a longer distance then movement of NP2 is not possible (280b').

(280) John gave the children a book.

- a. What did John give the children?
- b. ?Who did John give a book?
- b'. *Who did Bill think that John gave a book?

In the *with*-variant construction both *wh*-expressions can undergo *wh*-movement. The NP1 can undergo movement as is predicted if the locative variant mirrors the dative construction. However, we would predict that short movement of the NP2 expression would be odd for some speakers. However the *wh*-movement of NP1 is perfectly acceptable, as shown in (281). Even a long distance movement is fine (compare (281a) and (281b)). Variability again rests on whether speakers allow preposition stranding (compare (281a) and (281a')). The flexibility is also presented in (282) for the verb *spray*.

(281) John loaded the truck with the boxes.

- a. With what did John load the truck?
- a'. What did John load the truck with?
- b. What did Bill think that John loaded the truck with?

(282) John sprayed the wall with the paint.

- a. With what did John spray the wall?
- a'. What did John spray the wall with?
- b. What did Bill think that John sprayed the wall with?

In this subsection, I have presented further evidence that the dative and the locative variant constructions can be compared as they both allow *wh*-movement of either object, whilst a comparison of the double-object construction and the *with*-variant construction is more complex. Both constructions allow the movement of NP1, but movement of NP2 is subject to a degree of variability. For the *with*-variant construction, movement of NP2 is allowed and speaker variability rests on whether preposition stranding is allowed. In the double-object construction, speaker variability rests on whether movement of NP2 is allowed at all; the acceptability being improved by modification of the NP which increases the phonological length of the expression. If the acceptability of *wh*-movement of NP2 in a double-object construction is sensitive only to the modified structure of NP1, then the *with*-variant construction and the double-object construction cannot be compared. However, as we shall see in chapter 4, it is the relative phonological length of NP1 that is important in driving word order. This means we cannot discount the possibility that the double-object and *with*-variant constructions do indeed have comparable structures in respect to this data. Problematically for this account, when *wh*-movement involves movement out of an embedded clause the unacceptability of moving NP2 is more noticeable. This is presented in respect to so-called *tough* movement.

3.5.4.2. Tough Movement

This refers to sentences in which the subject of a main clause is logically the object of an embedded non-finite verb as shown in (283). It is termed tough movement purely because initial examples such as (283) involved the word *tough* (cf. Rosenbaum, 1967).

- (283) a. It is *tough/easy* to please John.
b. John_i is *tough/easy* to please e_i

In a dative construction, both the NP1 (284a) and NP2 (284b) can become the subject of a *tough* construction. However, for NP2, the preposition must be left stranded (compare (284b) and (284b')).

- (284) a. [Such spacious flats]_i are easy to rent e_i to young couples.
b. [Young couples]_i are easy to rent such spacious flats to e_i.
b'. *[to young people]_i are easy to rent such spacious flats e_i.

(Crăiniceanu and Baciu, 2007: 182. Their 9'.)

The same flexibility applies to the locative variant construction. The NP1 can become the subject of a *tough* construction (285a). The NP2 can also become the subject of this construction but again the preposition must be stranded (285b).

- (285) It is easy to load such small boxes onto empty trucks.
a. Such small boxes are easy to load onto empty trucks.
b. [Empty trucks]_i are easy to load such small boxes onto e_i.
b'. *[Onto empty trucks]_i are easy to load such small boxes e_i.

The double-object construction is more restrictive than the dative and locative variant constructions. The NP1 of a double-object construction cannot become the subject of a *tough* construction (286a). On the other hand, the NP2 of a double-object construction can marginally become the subject of a *tough* construction but judgements of acceptability vary (286b).

(286) It is easy to rent young people such spacious flats.

- a. *[Such spacious flats]_i are easy to rent young couples e_i.
- b. *?[Young couples] are easy to rent e_i such spacious flats.

(Crăiniceanu and Baci, 2007: 182. Their 9.)

The *with*-variant construction does not mirror the double-object construction for this data, as I show in (287). The NP1 of the *with*-variant construction can become the subject (287a), but only if the preposition is stranded (compare (287a')). However, the NP2 of the *with*-variant construction can also become the subject of a *tough* construction (287b) unlike the NP2 of the double-object construction.

(287) It is easy to load empty trucks with such small boxes.

- a. [Such small boxes]_i are easy to load empty trucks with e_i.
- a'. *[With Such small boxes] are easy to load empty trucks e_i.
- b. [Empty trucks] are easy to load e_i with such small boxes.

In this section I have shown that another example of A-bar movement gives the wrong result. Although the dative and locative variant constructions seem to pattern together, the *with*-variant and the double-object construction do not. It would seem that again the presence of a stranded preposition facilitates the acceptability of its NP complement appearing in a non-argument position because only when a preposition is present and it is subsequently left stranded can the argument appear as a subject of a *tough* construction. Although the presence or absence of a preposition does not

necessarily cause a difference in the relative placement of arguments in a structure nevertheless the effect of its presence (and absence) needs to be accounted for. As yet, I do not have a fully worked out account, although I do point to some possible avenues in chapter 6.

We now move to Relativisation. The data shows that Relativisation in restricted relative clauses is highly restricted for a double-object construction but not for the *with*-variant construction as the claim for parallelism predicts.

3.5.4.4. Relativisation

A relative clause contains “a relative pronoun (*who/whose/which*) that refers back to an antecedent in a higher clause (*generally one which immediately precedes the relative wh-expression*).” (Radford, 2004: 223). A restrictive relative clause is a subordinate clause that modifies a noun – the *head* of the relative clause. The relativised constituent in the matrix clause is semantically and syntactically related to the gap inside the restrictive relative clause. In other words, it has a *pivot* function (cf. De Vries, 2002). In (288) the relativised constituent *the girl* is modified by the relative clause *that I kissed yesterday* which is introduced by the relative pronoun *who* or the complementiser *that*. Furthermore, the NP *the girl* functions as a *pivot* as it is syntactically the subject in the matrix clause and the object in the relative clause.

(288) [The girl]_i that I kissed e_i yesterday has left.

In a dative construction, the NP1 (289a) or the NP2 (289b) can both be relativised. However in a double-object construction, the NP2 (290a) cannot be relativised. Relativisation of NP1 is again subject to speaker variability as illustrated in (290b).

(289) a. [The girl]_i that John gave flowers to e_i is his fiancée.

(*Derived from: John gave the flowers to the girl and that girl is his fiancée.*)

- b. [The flowers] that John gave e_i to his fiancée are beautiful.

(Derived from: John gave the flowers to his fiancée and those flowers are beautiful.)

- (290) a. ??The girl John gave the flowers is his fiancée.

(Derived from: John gave the girl the flowers and that girl is his fiancée.)

- b. The flowers that John gave the girl are beautiful.

(Derived from: John gave the girl the flowers and those flowers are beautiful.)

The locative variant construction seems to pattern with the dative construction in allowing either NP1 or NP2 to become the subject of a restrictive relative clause, as shown in (261a) and (291b) respectively.

- (291) a. The boxes that I loaded onto the lorry are precious.

(Derived from: I loaded the boxes onto the lorry and those boxes are precious.)

- b. The lorry that I loaded the boxes onto is very big.

(Derived from: I loaded the boxes onto the lorry and the lorry is very big.)

However, the *with*-variant does not pattern with the double-object construction as it allows the NP1 to relativise (292a) but only if the preposition is stranded (compare with 292a'). The NP1 is free to become the subject of a restrictive relative clause (292b).

(292) a. The boxes that I loaded the lorry with are precious.

a'. *With the boxes that I loaded the lorry are precious.

(Derived from: I loaded the lorry with the boxes and those boxes are precious.)

b. The lorry that I loaded with boxes is very big.

(Derived from: I loaded the lorry with the boxes and that lorry is very big.)

This section has shown another example of how the double-object construction and the *with*-variant construction do not pattern together. The double-object construction seems more restrictive in what it allows to be moved from its canonical position. The dative and locative variant constructions again seem to exhibit the same level of flexibility. Section (3.5) has shown that there are phenomena that do not directly support the idea that the structures involved in the spray/load and dative alternations are parallel. The data from A-bar movement is problematic as NP1 movement in the double-object construction is subject to speaker variability, which is not mirrored in judgements of the *with*-variant construction. In addition, the presence of the preposition *within* the *with*-variant construction seems to allow judgements that are not possible in the double-object construction. The preposition *with* is subject not only to judgements of preposition stranding or pied-piping, but also requirements on whether the preposition is pied-piped or stranded. Problems with comparing these alternations also revolve around whether the verbs that are involved in the alternations form natural classes. Recall that in unaccusative structures, verbs that have been claimed to belong to the same classes also seem to show variability. Underlying many of the incompatibilities shown in section (3.5) is the persistence of acceptable structures being associated with the presence of a preposition. When a preposition is absent from a construction (namely the double-object construction) then on many occasions a derived structure is unacceptable. It appears that the presence of the NP1 preposition in the *with*-variant construction confounds this comparison with the double-object construction. However, because of speaker variability and the non-uniform behaviour of verbs which supposedly belong to the same class, the hypothesis that the structures in the dative alternation are the same as the structures in the spray/load alternation cannot be excluded outright.

3.6. Chapter summary

In this chapter I have presented a wide range of data that has been standardly assumed to be sensitive to syntactic structure. This data has been previously used to indicate differences between the structures of the dative and double-object constructions. I have taken this data and applied it to the spray/load alternation in order to probe the structure of its constructions to see if they mirror the constructions in the dative alternation. Overall this data is positive in providing support to the hypothesis that the structures in the spray/load alternation are parallel to the structures in the dative alternation. A range of this data shows that restrictions observed in double-object constructions are mirrored in *with*-variant constructions. These were scope relations, pair-list readings, the formation of passive structures, the formation of deverbal nominals, sluicing ellipsis, *do so* substitution, and floating quantifiers. It was shown that some data was inconclusive. The data from unaccusative structures indicated that the verbs that have been included in spray/load and dative classes may not pattern in the same way. It was demonstrated that types of A-bar movement were inconclusive as they exhibit a wide range of speaker variability such as that found with *wh*-movement. Other types of A-bar movement did contradict the claim such as *tough* movement and relativisation. The data also showed that synthetic compounds and the *right*-modification of verb particles did not pattern well with the claim of parallelism. However, far more data does pattern in the right direction. As such, the hypothesis that the locative construction mirrors that of the dative construction, and that the *with*-variant construction mirrors that of the double-object construction is well supported. The comprehensive analysis of these constructions is new and goes some way to understanding the structure of the spray/load alternation. Evidence strongly suggests that the locative variant construction patterns with the dative construction, which means we can assign the locative variant construction with the ascending structure in Janke and Neeleman (2012). Although slightly less conclusive, most of the evidence is in favour of the *with*-variant construction patterning with the double-object construction, which would mean that the *with*-variant construction can be assigned the descending structure of Janke and Neeleman (2012). Now that the structure of the spray/load alternation has been established, and it has been argued that both variants of the spray/load alternation are identified with identical thematic feature clusters, the question remains as to why the alternation exists in the first place. This motivation is claimed to be determined by the context rather than an intentional difference in semantics. In chapter 4 and 5, we address this hypothesis directly with two experiments. This series of experiments received ethical approval (ref: 0341314). In chapter 4, the default preference for one of the variants of the spray/load alternation and one of the variants of the dative alternation is established. Chapter 5 attempts to affect this preference by presenting visual stimuli that differ in the distance information of objects in a scene.

Chapter 4. Establishing a baseline preference for the spray/load and the dative alternation

4.1. Introduction

In this chapter I present an online forced-choice questionnaire. The purpose of this experiment is to establish whether participants exhibit a general preference for one of the two alternations we have been discussing in the absence of any cues. Specifically, it tests which, out of the locative construction and the *with*-variant construction from the spray/load alternation is preferred, and which, from the dative construction and the double-object construction in the dative alternation is preferred. This is important because in chapter 5, we test whether the egocentric perception of distance affects participants' preference of these structures. Knowing the baseline preference is an essential precursor to measuring the effects of these extra-linguistic variables accurately. The idea for the current experiment is to provide a neutral condition where no prime is presented, and properties of the object referring expressions are controlled for.

On the null hypothesis that preferences for a construction from the spray/load alternation and the dative alternation are similarly affected by the form of their arguments, the referring expressions in an alternation pair in both the dative alternation and spray/load alternation are balanced. This is important because a multitude of factors may influence the preference for a particular argument order (cf. Bresnan et al., 2007). In this respect, the current experiment is an improvement on earlier studies, which have attempted to establish a preference for a particular construction without adequately matching the form of their referring expressions. A lot of research, for example, has tended to rely on corpora when examining the interplay between competing variables (e.g. Gries, 2003; Wasow and Arnold, 2003; Gries and Stefanowitsch, 2004; Bresnan et al., 2007; Ozón, 2009; Bresnan and Ford, 2010), which, being spontaneously produced, provides inherently 'noisy' data. Another point is that in corpora, contextual information is often lost and so in many respects it becomes unauthentic as it has "only a reflected reality" (Widdowson, 2007:7). This means we cannot accept any measure of preference for a particular construction extracted from corpora on face value, as we cannot claim with certainty that a use of particular form has not been influenced by further selectional restrictions embedded in the context, the details of which are unavailable to us. "The circumstances of [...] production can only be apprehended in the context of the knowledge of the participants [...]" (Cook, 1995: 42). To my knowledge, no study to date has attempted to establish a general preference for either the spray/load or dative alternations in which the effect of context has been adequately

controlled, and the properties of object referring expressions have been matched. It is believed that by providing a context-free environment, where each expression is new to the task and no expression is repeated one can identify a general preference for one or other of the relevant constructions. Based upon the control of context and by matching the form of referring expressions, it is assumed that participants will show an overall preference for one of the constructions in the spray/load alternation, and one of the constructions in the dative alternation. To form a specific hypothesis, I follow the claim in Janke and Neeleman (2012), discussed in (2.12), that the dative construction is the least complex, and therefore most economic, of the two constructions in the dative alternation as it is subject to fewer syntactic operations than the double-object construction. Specifically, the double-object construction requires movement of the verb, which is not so for the dative construction. With this claim in mind, and based on an assumption that when faced with two options (all else being equal), participants would opt for a choice that requires the least effort (e.g. Hawkins, 1990; 2004), it is hypothesised that the dative construction will be preferred over the double-object construction. Continuing with the claim in this thesis that the structures in the spray/load alternation are comparable with the structures in the dative alternation, it is also hypothesised that participants will show preference for the locative construction over the *with*-variant construction. Recall from chapter 3 that the evidence suggests that the locative variant and dative constructions have the same structure, which is distinct from the structure of the double-object and *with*-variant constructions. Moreover, the structure of the *with*-variant construction is comparable with the structure of the double-object construction. A counter claim in the literature is that the structure of the *with*-variant construction is not comparable with the structure of the double-object construction and in fact has the same structure as the dative construction (e.g. Baker, 1997). Showing that there is a significant preference in the absence of context for the locative variant construction over the *with*-variant construction goes some way in weakening that proposal. Before the introduction of the experiment in this chapter, the factors that are considered to be important in influencing a participant's preference are discussed. We begin the discussion by introducing what is meant by the linguistic context, before presenting the features of the linguistic context that impact on word order preferences.

4.1.1. The linguistic context

The linguistic context here refers to properties of language available in a particular environment to interlocutors prior to generating a target sentence. It also refers to the grammatical, phonological, and semantic properties of the linguistic units in the target sentence as well as the structure of the

target sentence itself. It is well documented that properties of the linguistic context particularly of referring expressions can interact with word order preferences. In what follows, I only discuss those properties of the linguistic context that may impact on the experimental design in this thesis. I begin with the same property that ended the section about the visual context; namely animacy, before progressing to phonological weight, grammatical number, and definiteness, all of which need to be controlled for. By balancing the animacy, definiteness, number properties, the number of words, and minimising the relative difference in syllable of the object referring expressions then a context-free preference is revealed.

4.1.2. Animacy and referring expressions

In English, animacy is a semantic property of referents that is only visible in referring expressions. It essentially refers to whether an expression refers to something that is alive (in which case it is *animate*) such as a *dog*, or not (in which case it is *inanimate*) such as a *table*. In other languages, animacy can be a grammatical category that has linguistic effects such as agreement relations between a referring expression and a verb (e.g. Navajo. Cf. Young and Morgan, 1987). As a semantic property of referents, animacy has been shown to have linguistic effects. For example, a speaker is more likely to refer to an animate referent with a pronoun than an inanimate referent (Dahl and Fraurud, 1996; Fukumara and van Gompel, 2011). Bock and Warren (1985) claim that this is because mental representations of animate entities are easier to access than inanimate ones. However, as pointed out by Vogels, Krahmar, and Maes (2013) animacy is not solely dependent on a lexical item such as using the word *human*, but may be influenced by non-linguistic conceptual properties of animacy such as entities that move. This means that *a car* may be considered more animate than *a book* (e.g. Rosenbach, 2008). It has been shown that the property of animacy has word order effects (e.g. Bock et al., 1992; Rosenbach, 2005). Fukumara and van Gompel (2011) observed that in a story completion task, animate entities were more frequently chosen by adults as the subject of a story continuation task compared to inanimates. Rosenbach (2005) showed experimentally that animacy affected the preference for an *s*-genitive or an *of*-genitive noun phrase in English. Participants preferred a structure where the animate entity came first (*the boy's eyes* versus *eyes of the boy*) even when other features of the linguistic context were taken into account. This suggests that animacy has robust effects in language choice. Ferreira (1994) found that verb type and animacy affected the speaker's choice of passive or active voice sentences. Participants were more likely to prefer a structure in which the animate entity appeared first. This shows that animacy also impacts on sentence structure. In a comparative study of New Zealand and American Englishes using corpus data,

Bresnan and Hay (2008) found that with the verb *give*, animate *recipients* were correlated with a preference for a double-object construction. This links directly to the structures in this thesis. Animacy has been shown to affect the dative alternation and so this is taken into account. Following the thesis' claim that the constructions of the variants of the spray/load alternation parallel those of the dative alternation it is important that this feature is balanced as part of the experimental design. The test sentences in the experiments in chapter 4 and 5 either contain grammatical objects that are animate, or two grammatical objects that are inanimate. In chapter 5 these correspond to the animacy of the visual objects in the accompanying images.

4.1.3. Phonological weight

The phonological weight of a linguistic expression refers to the phonological features that form a phonological realisation of a linguistic expression (Wasow and Arnold, 2003)⁵⁹. It is a linguistic property that has been consistently shown to affect where a referring expression will appear in a sentence. The phonological length of an expression can be determined in many ways including the number of words in an expression, the number of syllables in the expression, and the number of phrases that make up the expression. Wasow (1997) noted that these measures of weight are so tightly correlated that it is impossible to separate them to measure their individual effect. It has often been observed that a constituent that is shorter in length often precedes a constituent that is longer. Particularly, it was observed that a longer constituent is preferred toward the end of a sentence. This was termed 'the principle of end-weight' by Quirk et al. (1972). In the case of the dative alternation it has been observed that the preference for one construction over the other is influenced by the relative weight of their object expressions (e.g. Wasow, 1997; Wasow and Arnold, 2003) as shown in (293). In this example, the non-preferred construction is preceded by %.

⁵⁹ Another characteristic of phonological weight is prosody – the stress pattern of an expression. As this study is not investigating spoken language, we omit the inclusion of prosody in this analysis. However, prosody has been argued to be a factor of phonological weight which has been argued to affect which construction is realised in the dative alternation (Antilla, 2008). This study is an analysis of prosodically annotated corpus data. The drawback to this study is that it is based purely on the melodic pattern of prosody in English, and does not take into account the use of prosody on particular information-structurally relevant constituents such as 'Focus'. Any corpus data of conversational data must take context into account. The idea that prosody marks elements that correspond to Information Structural concepts is a current area of interest in both the Information Structure and Phonology literature (e.g. Selkirk, 2008).

- (293) a. % Chris gave (a bowl of Mom's traditional cranberry sauce)_{NP1} (to Terry)_{NP2}.
b. Mary gave (Terry)_{NP2} (a bowl of Mom's traditional cranberry sauce)_{NP1}.

(Arnold et al., 2000: 28. Their 2.)

We will calculate length in terms of the number of syllables. In (293), NP1 has 13 syllables, and NP2 has 4. The preferred construction in (293) is the double-object construction as the shorter NP2 precedes the longer NP1. This effect is pronounced when there is a large difference between the number of syllables in each expression. However, Bresnan et al. (2007) observed that it is the relative difference between the number of syllables in two referring expressions rather than an absolute number of syllables in an expression that can affect the order of objects in the dative alternation. The larger the difference the more pronounced the effect. In light of this evidence, we account for phonological weight in the experimental design by balancing the referring expressions used in a trial in terms of a similar number of syllables (e.g. *the zebra* vs. *the lion*). The effect of phonological weight is minimised by limiting a difference in syllable length to $n+1$. The discussion now moves onto the effect of grammatical number on the spray/load and dative alternations. For this, only limited reference is found in the literature.

4.1.4. Number

A referring expression can be marked in such a way as to indicate whether the expression refers to one referent or many referents (e.g. *dog* vs. *dogs*, *man* vs., *men*). Bresnan and Nikitina (2003) and Bresnan et al. (2007) proposed that this feature of referring expressions could also have an influence on the preference for one of the constructions in the dative alternation. Haspelmath (2004) claims that singular marked expressions are more common than plural marked expressions across the world's languages, and this difference in frequency informs word order preference. The claim is that number affects the object order in the dative alternation and that the object referring expression that has the more frequent feature tends to precede the object referring expression that has the less frequent feature. Haspelmath (2004) makes this claim but provides no evidence that the distinction between singular and plural informs predictions about the preference for either the dative construction or the double-object construction. Aissen (2003) provides evidence from cross-linguistic usage data that singular object pronouns (e.g. *him*) occurred more frequently than plural object pronouns (e.g. *them*).

Bresnan et al. (2007) argue that the relative frequency of an object expression is a predictor of its preferred position, and so they proposed that there would be more instances of dative constructions with singular NP1 objects and plural NP2 objects than dative constructions with plural NP1 objects. There would also be more instances of double-object constructions with plural NP1 objects and singular NP2 objects than double-object constructions with singular NP1 objects and plural NP2 objects. However, Bresnan and Nikitina (2003) and Bresnan et al. (2007) assimilate this feature with other grammatical features such as person and so no explicit effect was presented. However, based on these arguments a possible effect of number is accounted for in the experimental design by marking both object expressions in a sentence as singular, or both as plural. It is the case that in the spray/load alternation it is easier to construct sentences whose referring expressions are both plural rather than both singular. This is because spray/load verbs tend to describe events with plural *themes*. In order to balance the effect of this value, all *locative* expressions were marked as plural. As such all referring expressions in the spray/load alternation are marked as plural expressions (e.g. *Sarah will load luggage onto aeroplanes* vs. *Sarah will load aeroplanes with luggage*). In the dative alternation sentences, all referring expressions are marked as singular. This is implemented because it is easier to depict scenes with singular referents as a whole. The discussion now moves on to the effect of definiteness.

4.1.5. Definiteness, definite and indefinite articles

Definiteness is generally viewed as a category concerned with the grammaticalization of identifiability and nonidentifiability of referents. Definiteness is a semantic-pragmatic notion that is closely associated with the use of definite articles such as *the*, *those*, or *these*. Indefiniteness is closely associated with the use of indefinite articles such as *a* and *an*. A referring expression that identifies a particular referent (or referents) in the world is usually marked with the definite article. If a referent has been referred to before in a discourse, then this referring expression is likely to appear with the definite article. The referring expression of a referent that is new to a discourse, or cannot be uniquely identified is typically marked by an indefinite article. It has been observed that in the dative alternation, when one object referring expression is marked with a definite article and the other object is marked with an indefinite article then the object with the definite article tends to be preferred in a sentence where it precedes the expression marked with the indefinite article. This has been proposed to be an indication of the preference for known material to appear before new material (e.g. Chafe, 1976; Gundel, 1988; Prince, 1992; Arnold and Wasow, 2003). This is illustrated in (294).

- (294) a. % Kim handed a toy to the baby
b. Kim handed the baby a toy

(Arnold and Wasow, 2003:2. Their 2.)

Gundel (1988: 229) labelled this generalization the “given before new principle” and formulated it as: “State what is given before what is new in relation to it.” Ballantyne (2004), Gundel, Hedberg, and Zacharski (1993), Gundel et al. (2010), Wind Cowles and Ferreira (2012) (among many others) propose that this principle relates to the familiarity of a referent in a discourse. This is a complex principle of Information Structure that is not strictly relevant to our thesis so we point the reader to these studies and references within. What is of interest here is that in the dative alternation and the spray/load alternation, if one object referring expression is marked as definite and the other referring expression is marked as indefinite then the former is more likely to appear preceding the latter (Bresnan et al., 2007). In the dative alternation when it is the NP2 that has the definite article and the NP1 that has the indefinite article, then it is more likely that a double-object construction is preferred. When the NP1 is marked as definite and NP2 as indefinite then it is more likely that a dative construction is preferred choice, as shown in (295) and (296). The (a) examples are generally preferred to the (b) examples. Again, % signifies the least preferred sentence.

- (295) a. Sam brought the girl a puppy.
b. %Sam brought a puppy to the girl.

- (296) a. %Sam brought a girl the puppy.
b. Sam brought the puppy to a girl.

Things are more complex for the spray/load alternation. Due to the fact that spray/load sentences tend to occur with a plural NP1. Therefore a balancing plural NP2 is difficult to assign with an indefinite

article in English. As such we treat a bare NP as less definite than an overtly marked definite NP. As illustrated in (297) and (298) the definite NP is preferred in a position preceding the bare NP.

- (297) a. Sam loaded the boxes on trucks.
b. %Sam loaded boxes on the trucks.
- (298) a. Sam loaded the trucks with boxes
b. %Sam loaded trucks with the boxes.

In order to mitigate any effect of definiteness in the experimental design, object expressions are created with definite articles for use in the dative alternation trial sentences (e.g. *Sarah will feed the zebra to the lion*). For the spray/load alternation only bare noun phrases are used (e.g. *Sarah will pack bombs into boxes*). This set is not marked with definite articles because when both objects are marked with a definite article they are more difficult to articulate in these constructions, and this may interfere with the processing of the sentences by the participants. (Compare *Sarah will load luggage into aeroplanes* vs. *Sarah will load the luggage into the aeroplanes*, and *Sarah will load the aeroplanes with the luggage* vs. *Sarah will load aeroplanes with luggage*).

Now the factors that can impact on word order preferences in general and the spray/load and dative alternation in particular have been made explicit, we can proceed with the presentation of the experiment. Taking into account these influencing factors the referring expressions in this experiment are balanced in terms of animacy, definiteness, plurality, the number of words in an expression, and the relative syllable length of the NP1 and NP2; the difference in the number of syllables between the expressions was no more than one. In the dative construction, the preposition was not included in this count⁶⁰.

⁶⁰ To include the preposition in the word count would have meant that we would have had to use different referring expressions for the NP2s in the dative construction and the double-object construction. In the double-object construction, the NP2 expression would need to have been augmented with the addition of an extra word in order to account for the absence of the preposition. This change in the type and complexity of referring expression is problematic. Such difference between the referring expressions indicates to a hearer of a difference in accessibility that should be attributed to their referents (cf. Ariel, 1988).

Now the linguistic determinants of argument order preferences that are considered important to control in the experimental design have been made clear, we proceed with the presentation of the first experiment.

4.2. Method

4.2.1. Participants

81 adults aged between 18 and 70 took part in the study on a voluntary basis. Participants were recruited via calls put out on the university website, by email and on social networks. All were native speakers of English and none had any neurocognitive impairments. All participants had normal or corrected to normal vision. Of the 81 participants only 62 completed the survey in full. The incomplete surveys were discarded, thus the total number of participants included for analysis was 62.

4.2.2. Materials and procedure

This experiment employed an online forced-choice questionnaire. Having consented to take part, participants were given access to the link to the on-line survey. Participants were informed that the purpose of the questionnaire was to examine regional preferences for different kinds of sentence constructions. They were assured that their responses would remain anonymous. Participants clicked on the online link to the survey, and before entering the task itself, were asked to which age range they belonged, to confirm that they were native speakers of English, and to indicate the geographical region from which they came. They were then instructed that they would see a series of sentence pairs. Their task was to select the sentence that they preferred by clicking on the relevant sentence. They were instructed that the survey would not continue until they had made their selection on the presented trial. At the end of the survey they were thanked for their participation and on this final screen, it was made clear that in fact the true purpose of the experiment was to examine the preference for one of the constructions of the dative alternation and one of the constructions from the spray/load alternations (see Appendix 6). Participants were presented with an option to remove their data. The experiment was then terminated. The survey was hosted online with Survey Monkey (*surveymonkey.net*) and the online link to the survey was posted on the experimenter's social network page (*facebook.com*). Data was extracted from *Survey Monkey* and transferred to *Microsoft excel*, and then coded for statistical analysis using *SPSS 21* statistical software.

4.2.3. Sentences tested

The survey was made up of a series of sentences, where for each sentence, participants were asked to choose the sentence they preferred from a choice of two options. So, for example, when presented with the sentences in (299), they were asked to choose which sentence they preferred, and they did so by clicking on the preferred sentence.

- (299) a. The librarian stacked books on shelves.
 b. The librarian stacked shelves with books.

The questionnaire included two verb sets – a set of verbs involved in the spray/load alternation, and a set of verbs involved in the dative alternation. Each set tested a preference for a different type of construction: either a locative construction or a *with*-variant construction from the spray/load alternation set, and a dative construction or a double-object construction from the dative alternation set. A sentence pair was created for each verb in which the object referring expressions were matched for animacy, definiteness, and the number of words in the expression. The relative difference in syllable number between the expressions was minimised to no more than one (*see figure 1.*).

Figure 1. Critical trial verbs and their matched referring expressions

ALTERNATION	VERB	NP1	NP2
Dative	toss	the fish	the seal
Dative	show	the painting	the camera
Dative	hand	the villain	the police
Dative	bring	the patient	the doctor
Dative	throw	the rabbit	the hound
Dative	pass	the infant	the parent
Spray/Load	splash	paint	desks
Spray/Load	pack	jam	jars
Spray/Load	lay	cutlery	tables
Spray/Load	load	luggage	aeroplanes
Spray/Load	stack	books	shelves
Spray/Load	pile	bricks	tables

In the dative verb set, all referring expressions were singular, and in the spray/load verb set all referring expressions were plural; 2x count noun pairs, and 4x count and non-count noun pairs. In the dative verb set, all referring expressions were accompanied by a definite article (e.g. *the shark*); this was a grammatical requirement for singular referring expressions that uses common nouns. In the spray/load verb set, the referring expressions were plural and bare. This was because the semantics of the verbs in this condition require a plural NP1. (*Sarah stacked books on tables* versus **Sarah stacked the book on table*). The definite article was excluded from these expressions because the sentences were considered less natural with them (e.g. *Sarah loaded the aeroplanes with the luggage* vs. *Sarah loaded aeroplanes with luggage*) and this was considered to be detrimental to the experiment, as it may have interfered with the sentence processing. An example of a sentence from the dative verb set is given below in (300) and an example from the spray/load verb set is given in (301). The complete list can be found in Appendix 1. In each trial, one sentence appeared above the other. Their orders were pseudo-randomised so that each participant encountered an equal number of each sentence type in the first position. The critical trials were also pseudo-randomised so that they were dispersed evenly among the fillers.

- (300) a. The trainer tossed the fish to the seal. (*dative construction*)
 b. The trainer tossed the seal the fish. (*double-object construction*)
- (301) a. Peter splashed paint onto desks. (*locative construction*)
 b. Peter splashed desks with paint. (*with-variant construction*)

Six dative alternation verbs were included in the questionnaire (*toss, show, hand, bring, throw, and pass*) as well as six spray/load alternation verbs (*splash, pack, lay, load, stack, and pile*), amounting to twelve critical trials. The frequencies for these verbs are given in Figure 2, which is taken from the University of Lancaster “Word Frequency of Written and Spoken English” corpus (<http://ucrel.lancs.ac.uk/bncfreq/flists.html>). Two of the verbs used in this experiment were not found on the corpus which has been indicated in the table by ‘N/A’. It can be seen that the verbs that are involved in the dative alternation are generally more frequent in this corpus than verbs that are involved in the spray/load alternation. This is considered to be a consequence of the kind of event that these verbs describe – giving and bringing events are more commonplace than packing and piling

events. Eighteen fillers were also used resulting in thirty trials in total. An example of a sentence pair from each verb set is given in (302) and (303).

Figure 2. Frequency list of verbs by lemma: occurrences per million

Alternation	Verb	Frequency per Million
Dative	Toss	13
Dative	Show	598
Dative	Hand	54
Dative	Bring	439
Dative	Throw	115
Dative	Pass	204
Spray/Load	Splash	N/A
Spray/Load	Pack	33
Spray/Load	Lay	104
Spray/Load	Load	22
Spray/Load	Stack	N/A
Spray/Load	Pile	11

(302) a. The trainer tossed the fish to the seal . (dative construction)

b. The trainer tossed the seal the fish. (double-object construction)

(303) a. Peter splashed paint on desks . (locative variant)

b. Peter splashed desks with paint. (with-variant construction)

The 18 fillers consisted of pairs of sentences and phrases. Each pair consisted of examples that also had two possible alternates. These alternates are commonly regarded as being subject to regional variability. This included two sentence pairs that differed in terms of adverb placement, as in (304), three sentence pairs that differed in terms of prepositional choice, one of which is illustrated in (305),

two sentence pairs that used preposition stranding, as in (306), one phrase pair in which infinitives were split, indicated in (307), two sentence pairs that differed in terms of whether or not they express the main tense of a sentence overtly, as in (308), two sentence pairs that differed in subject-verb agreement, shown in (309), two sentence pairs that differed in the presence of a resumptive pronoun that was coindexed with the sentential subject, (310), one sentence pair that differed in adjectival or relative clause modification of the head noun (311), one sentence pair that differed in the presence of an overt complimentiser (312), one sentence pair that differed in the presence of a negative argument or a negative polarity item, as in (313), and lastly, one wh-sentence pair that differed in whether it showed a crossover violation (314). The reader is referred to appendix 1 for the complete set.

- (304) a. Mary kissed the boys often.
b. Mary often kissed the boys.
- (305) a. Tom is different from Tim.
b. Tom is different to Tim.
- (306) a. At what did you look?
b. What did you look at?
- (307) a. To boldly go.
b. To go boldly.
- (308) a. I have just got home.
b. I just got home.
- (309) a. The data are important.
b. The data is important.
- (310) a. A helicopter most people don't have.
b. A helicopter most people don't have one.

- (311) a. Mary has a barking dog.
b. Mary has a dog that barks.
- (312) a. John is the man we expected to see.
b. John is the man that we expected to see.
- (313) a. They didn't see anyone in the house
b. They saw no one in the house
- (314) a. Which book did John wonder why Bill had read?
b. Which book did John think that Bill had read?

4.3. Results

Data was scored by collecting participants' preferences from the two choices given. In the spray/load verb set, if participants' selected a locative variant construction this was coded as '1', whereas a *with*-variant construction was coded as '0'. In the dative verb set, if participants' selected a dative construction this was also coded as '1', whereas a double-object construction was coded as '0'. Coding in this way mapped with the hypothesis that participants would exhibit a preference for a locative construction in the spray/load alternation and a dative construction in the dative alternation in the absence of any cues. Each set included six different verbs which were presented to participants once. This amounted to six trials for each set. For the spray/load verb set, responses were summed according to the number of times the locative variant was chosen. This resulted in a 7-point scale, ranging from 0 to 6. In the dative verb set, responses were summed according to the number of times the dative construction was chosen, which gave the same 7-point scale. The fillers were discarded prior to analysis.

4.3.1. Group comparisons

The responses in the spray/load set were analysed first. The medians indicated that participants were more likely to select the locative variant (median = 4) than the *with*-variant construction (median = 2). This was a significant difference as confirmed by a Wilcoxon signed rank test ($p < 0.001$). Figure 3

demonstrates the number of responses for each construction as well as the percentages from a total of 372 trials (6 x 62).

Figure 3. Total number and percentage of responses in the spray/load alternation

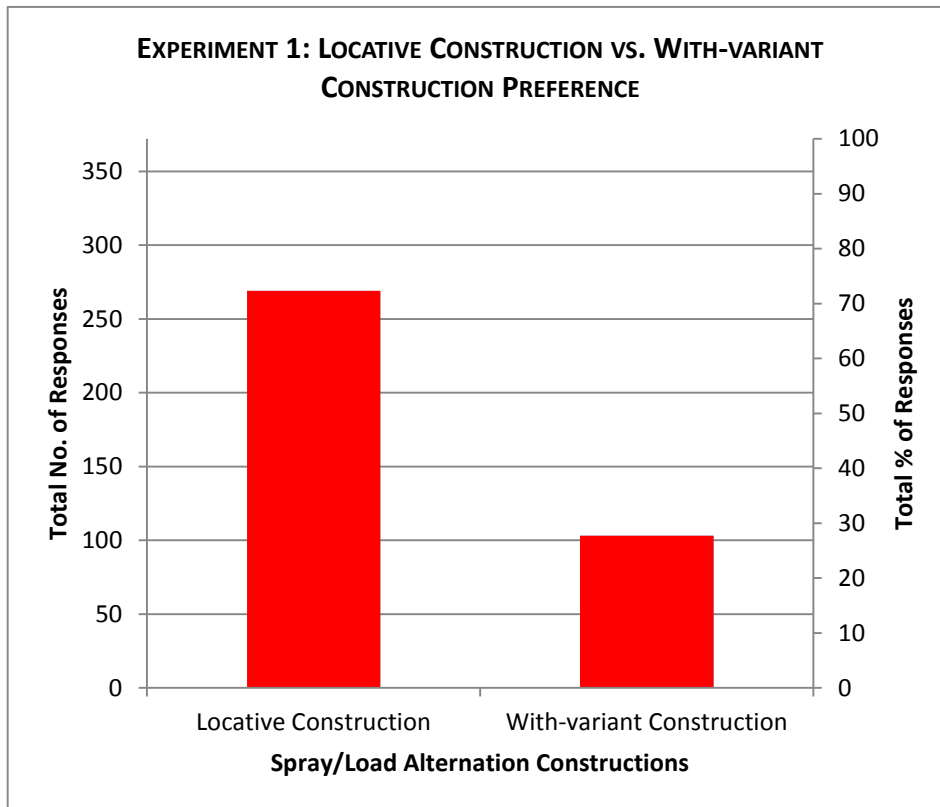

The responses in the dative verb set were analysed in the same way. The medians indicated that participants preferred the dative construction (Median = 5.5) over the double-object construction as predicted (Median = 0.5). A Wilcoxon was significant ($p < 0.001$). Figure 4 demonstrates the number of responses for each construction – as well as the percentages, again from a total of 372 trials (6 x 62).

Figure 4. Total number and percentage of responses in the dative alternation

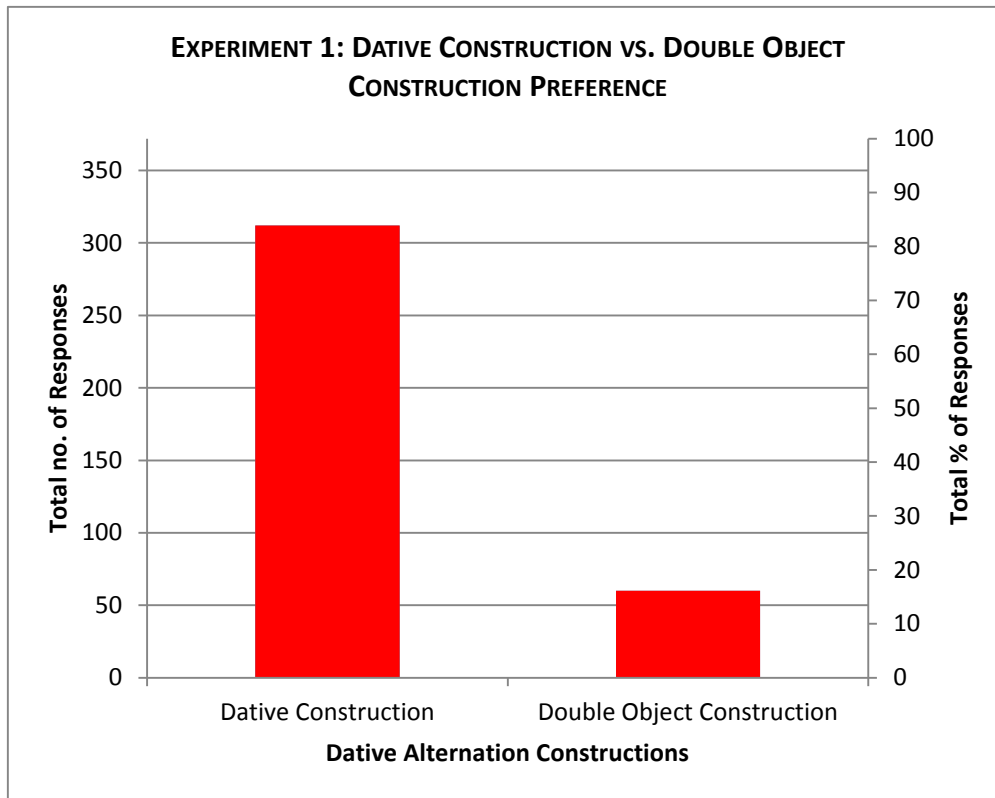

4.3.2. Individual comparisons

Firstly, for the spray/load alternation, 49 out of 62 participants (79.03%) patterned in the direction of an overall preference for a locative construction in a neutral context, 9 (14.5%) did not show any overall preference, and only 4 (6.45%) preferred the *with*-variant overall. This is illustrated in figure 5.

Figure 5. Total number and percentage of individual preferences for a construction from the spray/load alternation.

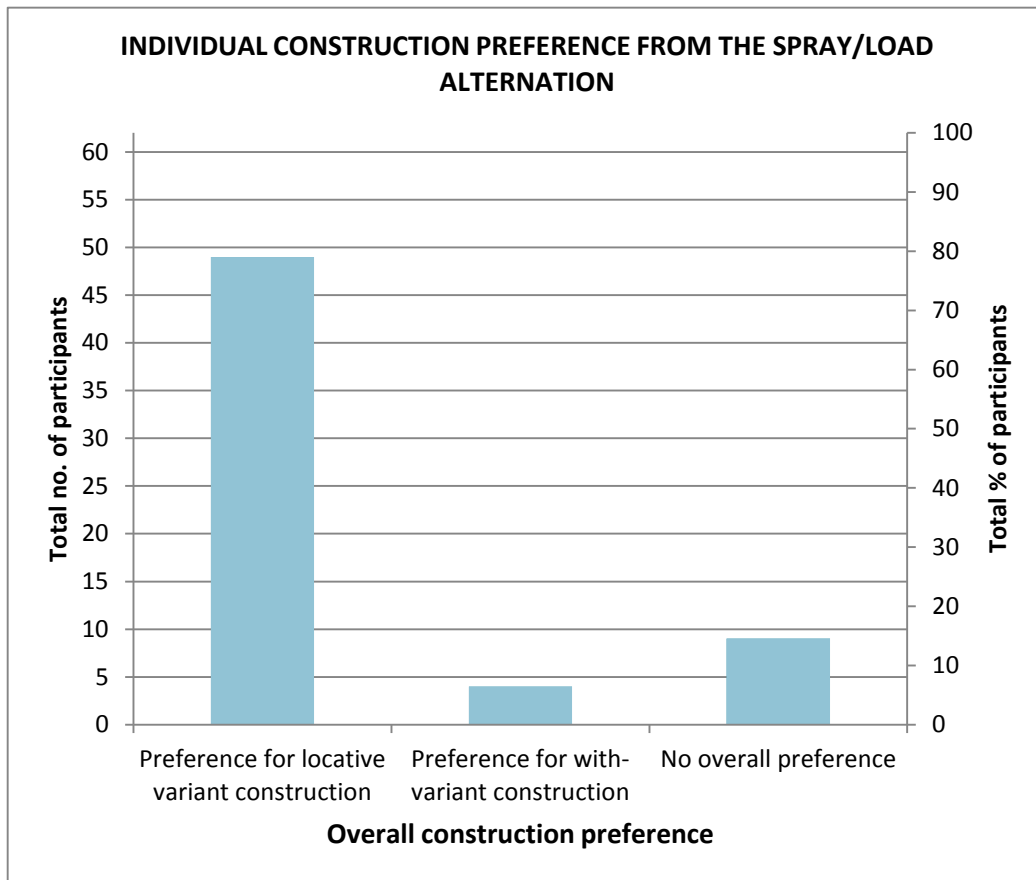

Secondly, for the dative alternation, 57 of the 62 participants (91.9%) patterned in the direction of a majority preference for a dative construction in the neutral context, 2 (3.23%) showed no preference, and only 3 (4.84%) showed an overall preference for the double-object construction. Interestingly, only one participant showed an overall preference for both the double-object and the *with*-variant construction. This is illustrated in figure 6.

Figure 6. Total number and percentage of individual preferences for a construction from the dative alternation

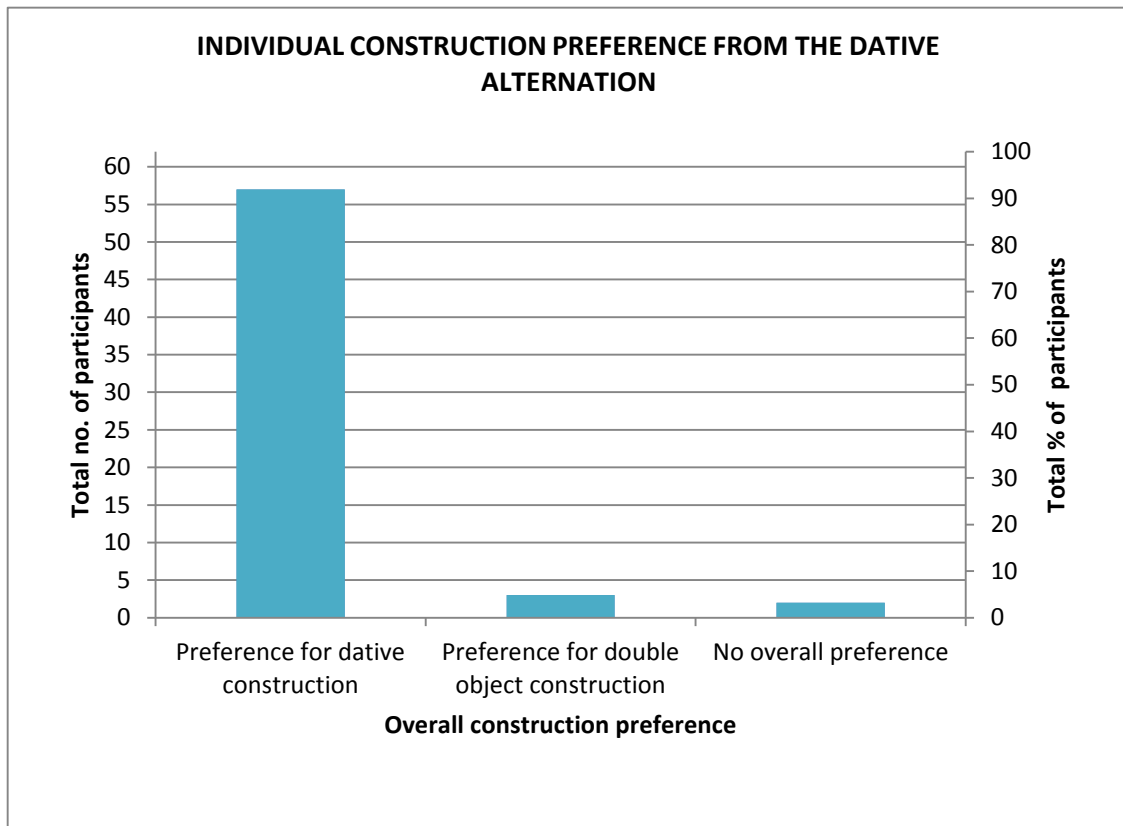

4.4. Discussion

The purpose of this study was to establish a preference for one of the variants from the spray/load alternation, and one of the variants from the dative alternation in the absence of contextual effects. The results of this study support the hypothesis that, all things being equal, preference is driven by economy in that both the locative variant construction and the dative construction were the preferred constructions from their respective alternations. Participants preferred the less complex structures in the absence of context. On an individual level, over 79.3% of participants patterned in the direction of an overall preference for a locative construction in a neutral context, and over 91.9% of participants patterned in the direction of an overall preference for a dative construction in the neutral context. Results show that the locative variant construction from the spray/load alternation and the dative construction from the dative alternation were significantly preferred over the *with*-variant construction and the double-object construction respectively in a neutral context.

There are several reasons why these findings are important. From a syntactic perspective, if we follow the tenet that economy is a strong motivation for structural choice, then the results indicate that the locative variant of the spray/load alternation is the least complex. This is because these structures were consistently preferred in the absence of any context. This has implications for how the structures for both the locative variant and the *with*-variant constructions should be viewed. Following the idea of economy motivating a preference between competing constructions, if both structures were equally complex as proposed by Baker (1997), then we could not have predicted such a strong bias toward the locative variant construction from the spray/load alternation. This means the structures in the spray/load alternation can be viewed as distinct; the locative variant is the more economical construction and the *with*-variant construction is the more complex. In the case of the dative alternation, the results also support the structures for the dative construction and the double-object construction being distinct. Following standard assumptions of economy, the preference for the dative construction gives support to the claim that the dative construction is the least complex structure of the alternation. The preference for the dative and locative variant constructions in the absence of context also provides the first tentative empirical step towards supporting the claim that the structures in the spray/load alternation are similar to the structures in the dative alternation as initially claimed by Speas (1990) and Larson (2014). If the constructions are to be paired for comparison, then we must compare the dative construction with the locative construction as they are the least complex of their respective alternation pair, and the *with*-variant construction with the double-object construction as they are the more complex of their respective alternation pair. These pairings provide additional support for the pairing and syntactic analysis from chapter 3.

The data from this first experiment also relates directly to the validity of the constructionist approach to these constructions. The verbs that are included in the spray/load class have one of two basic senses that remain constant: putting substances on (or removing from) surfaces, or putting things in (removing from) containers (e.g. Levin, 1993). The sub-classes of dative alternation verbs also have a basic sense within their class; essentially a sense of a caused locational change of an object from one location to another either explicitly or via a metaphoric link. This implies that the use of the verb evokes in the mind a default scene which stands for “a coherent schematization of experience” (Fillmore, 1985: 223). This schematic frame represents these default scenes in terms of specific inferences of participant roles. These roles are embedded in a general frame which “one needs to have knowledge of to properly understand the meaning of the verb” (van der Leek, 1996: 324). In the absence of contextual cues, it might be assumed that the default scene evoked by the verb and its thematic specification is a basic event type which then should tally with a basic syntactic frame, one in which the basic sense of the verb and its roles is systematically mapped onto a syntactic structure

(e.g. Jackendoff, 1990). Based on the results from the experiment, the basic spray/load event is mapped onto a locative variant construction for spray/load events, and a basic dative-type event is mapped onto dative construction for dative-type events. No cues were available to bias the participant in to viewing the scene in a particular way, and so the default interpretation should manifest. This implies that the basic sense of the event for both classes of verbs must be cause-motion as the dative and locative variant constructions were preferred in the absence of any cues. Recall that cause-motion has the sense that something inferred to be a *theme* is being affected in such a way that it is being moved by a force (typically inferred as an agent) toward a different location. If this sense is encoded into the event semantics of the verb, then what is not clear is what contribution to the meaning of the sentence is made by a cause-motion construction. Recall that it is claimed that unless motion is encoded in the verb's sense then the verb is incompatible with the cause-motion construction. This may account for why transitive and non-transitive verbs appear in unusual constructions, but what is unclear is the contribution made by the construction to the meaning of the event, if this meaning is already embedded in the basic sense of a dative or spray/load verb. If a 'conceptual path' meaning is the additional element contributed by the construction in a dative or a locative variant sentence, then again it is difficult to separate the contribution made by the construction as a whole that is different from the meaning contributed by a directional preposition whose form is also linked to the semantics of the verb. Construction grammar claims that a construction's meaning is not a composition of the meaning of its elements, but only of the frame itself. As such, construction grammar makes specific predictions about the spray/load and dative alternations: a dative construction cannot be associated with a cause-to-receive meaning. In the same way, the locative variant construction cannot be associated with a meaning in which the location's state has been completely changed facilitated by an instrument. Additionally, the cause-to-receive meaning associated with the double-object construction should not be an extended or an additional sense of a basic cause-motion event. It should be identified as an independent event frame that is distinct from cause-motion. In the same way, the change-of-state-plus-with-adjunct construction associated with the *with*-variant construction should not be an extended or an additional sense of a cause-motion event; rather it is distinctly the augmentation of a change of state event. The form-meaning correspondence of a construction and an event type is independent and underived. However, the results from the experiment suggest that this may not be the case as without a cue to a specific meaning, participants overwhelmingly opted for a dative and locative variant construction from the dative and spray/load alternations respectively. This suggests that something additional to constructional meaning is playing a role in construction preference, otherwise we would expect to see a preference for a construction to be no greater than chance. This can be accounted for if the verb contributes a basic cause-motion interpretation. The

thematic features that are profiled by the verb are then realised in a basic syntactic frame (a dative or locative variant construction). It is the hierarchical relation of the thematic clusters and the motivation of economy that constrain the form of the structure. This predicts that all dative and spray/load alternating verbs (if we accept that they form natural classes) should then be compatible with an underlying cause-motion interpretation if they manifest a dative or a locative variant construction in a context-free environment; indicative of the verbal sub-event. The evidence in chapter 5 will support this prediction when the preference for a double-object construction and a *with*-variant construction is shown not to be driven semantically

For the purpose of the experiment in chapter 5, the result of the study is important because it serves as a point of reference from which to measure the effect of the egocentric perception of distance by visually cueing the relative distance of referents. On the basis of this study, the baseline interpretations of the two constructions are now known, which enables the subsequent experiment to factor in this baseline interpretation when assessing whether visual cues that vary participants' perception of referent distance can affect this baseline.

4.5. Chapter summary

Having reached the end of this chapter, we have seen that there is an overwhelming preference for one of the variants in the spray/load alternation (the locative construction), and one of the variants in the dative alternation (the dative construction). We can now proceed to chapter 5, where sentences from the dative alternation and spray/load alternation will be accompanied by a visual context in which the egocentric perception of distance of the referential arguments in these constructions is manipulated. This will be carried out with a view to demonstrating that the egocentric perception of distance has an effect on the word order of spray/load and dative alternation sentences. The results of that experiment are also brought to bear on the theoretically driven syntactic, semantic, and information processing arguments that have been discussed in earlier chapters.

Chapter 5. The effect of the egocentric perception of distance on preferences in the spray/load and dative alternations

5.1. Introduction

The purpose of this experiment is to test for an effect of visual salience on the word order preferences of referents in double-complement sentences. Specifically, the experiment tests whether a participant's egocentric perception of referent distance in a visual scene can influence the order in which they prefer arguments to occur in sentences that take part in the spray/load alternation, and sentences that take part in the dative alternation. This preference of word order manifests as a preference for one of the particular variations in these alternations. As we saw in (2.18) this is based on research which has demonstrated that speakers prefer objects that capture their attention to appear earlier in a sentence than those that do not (e.g. Hull, 1943; Osgood and Bock, 1977; Macwhinney, 1977; Myachykov, 2007; Myachykov, Posner, & Tomlin, 2007; Slevc, 2011). It is thus assumed that, when faced with a picture, a person forms a mental representation of the depicted event. The mental representation of the event is influenced by a serial allocation of processing resources to the objects that are visible. The allocation of resources is triggered by features of the stimuli. All things being equal, a relative value of a particular property (for example, animacy) can capture attention, whereas an alternative relative value of that property (such as inanimacy) does not. Recall from (2.18.3) that when two objects are in competition for attention, the object that is relatively nearer to the viewer than the other object is more likely to capture attention first (Mazzo, Turatto, and Umiltà, 2005). Resources are then made available for the visual processing of the further object only after the first object has been processed. If an object is processed first, then it is more likely to be converted into a referring expression first. As such, this preference will influence the kind of construction that can accommodate its early processing. When there is a choice between two constructions to describe a particular event, then the construction that can accommodate the early processing of the referring expression will be preferred. In other words, the sentence construction should reflect the serial processing of objects. Therefore, if we can manipulate the visual salience of referents that correspond to NP1 and NP2 referring expressions, we would expect to see sentence preference effects in the spray/load and dative alternations. Recall that the binary-choice questionnaire in chapter 4 demonstrated a baseline preference for the locative (S V NP1 P NP2) and dative constructions (S V NP1 P NP2). This means that we would expect to see the preference for the

double-object and *with*-variant constructions (S V NP2 NP1) increase if we manipulate the distance location of the referent that corresponds to the NP2 so that it is nearer than the referent that corresponds to the NP1⁶¹. This is because the NP2 appears linearly in the constructions before the NP1, which is presumed to be a reflection of the serial order of processing the corresponding referents. The experiment is predicted to expose this effect.

In this experiment, visual salience is manipulated by presenting pairs of objects in pictures that vary in their depiction of relative distance from the participants. The general hypothesis for this experiment is that the perception of visual distance affects construction preference. The questionnaire in chapter 4 presented participants with these construction types in the absence of any contextual cues. This established that the baseline preference for the spray/load alternation is the locative construction and the baseline preference for the dative alternation is the dative construction. On this basis, it is predicted that a scene which depicts the referent corresponding to the NP2 in the foreground would alter that base-line sentence preference. To test this effect, the experiment has two conditions: one where the NP1 is in the foreground, and NP2 is in the background (condition 1), and one where NP1 is in the background and NP2 is in the foreground (condition 2). Specifically, for the spray/load alternation, when NP2 is in the foreground (condition 2), it is predicted that participants' preference for the *with*-variant over the locative-variant will be significantly higher than when NP2 is in the background (condition 1). For the dative alternation it is predicted that when the NP2 is in the foreground (condition 2), participants' preference for the double-object construction over the dative construction will be significantly higher than when the NP2 is in the background (condition 1). Since the previous experiment established that there was general preference for the locative construction in the spray/load alternation, and for the dative construction in the dative alternation, we are not concerned that participants still prefer the locative and the dative when the NP1 is in the foreground (condition 1). It is only important that they prefer the double-object construction and the *with*-variant construction more in condition 2.

In the previous chapter, we saw that the linguistic context has a significant part to play in word order preferences. Now we will see that the visual context can also impact on these preferences. The visual context is another contextual medium that interacts with the concept of attention. Attention was defined as the allocation of mental resources for the processing of information. This was shown to be

⁶¹ Given the inherent preference of the dative and locative variant constructions, it is much harder to reveal the effect of the egocentric perception in the dative and locative variant constructions. This is because any effect is competing with the inherent preference. A result is therefore very difficult to extract. Due to this complication only the change in preference for the double-object construction and *with*-variant construction is measured.

a serial process that selects some information for processing to the inhibition of other information. This was proposed to be due to the maintenance of the limited capacity of Working Memory in order to prevent overload. Focus was given to the egocentric perception of distance which is the experimental variable used in the current chapter. In the same way that the referring expressions in chapter 4 were balanced in terms of the linguistic context, the same strategy must be applied to the visual context in order to reveal the effect of the egocentric perception of distance separately to other attention allocating factors. In what follows, the features that are considered important to balance in the experimental design are discussed. The features considered to be important are colour, visual animacy, and novelty. Those features of the visual context, alongside the features of the linguistic context that were accounted for in chapter 4 are subsequently balanced in the design of the current experiment. We begin the discussion by introducing what is meant by the visual context, before presenting the relevant features of the visual context that are important to the experimental design.

5.1.1. The visual context

The term visual context refers to the visual features of images, scenes, and objects that are available to the perceptual processes of our eyes within our field of vision at a particular moment in time. Our visual environment can comprise a rich mosaic of features that are available to perception. Many of these features interact with attention. This means that in a particular visual environment there is likely to be competition for attention between features of the visual context. Visual search experiments have revealed a number of visual features that contribute to the likelihood that it captures attention. For example larger objects are more likely to capture attention than smaller objects (Proulx, 2010), as evident in the example in (315). Your attention is more likely to be captured by the larger fish before the smaller one.



It would take us too far afield to review all of these features here so the reader is pointed to Wolfe (1998a). The feature of the visual context which is of importance to this thesis is the egocentric perception of distance. This feature is hypothesised to interact with the preference for one of the variants of the spray/load alternation and one of the variants of the dative alternation. Distance information is not the only variable that can impact on word order preferences. Discussion now turns to two other relevant variables of a visual environment: colour information and the novelty of a stimulus.

5.1.2. Colour

A coloured object seem to ‘pop out’ of displays containing objects of a different colour (e.g. D’Zmura, 1991; Nagy and Sanchez, 1990; Treisman and Gelade, 1980), and seems to capture attention irrespective of the visual search task (e.g. Theeuwes, 1994). “A flash of yellow to your side when you step off the curb in New York City may be a speeding taxi, and it triggers a rapid shift in visual attention to its location.” (Fuller and Carrasco, 2006: 4032). However, what does not seem well documented is the overall effect of different colours on the salience of an object. The salience of a particular colour and subsequently its attention capturing effect is said to depend on the image categories in natural scenes (Parkhurst et al., 2002) rather than any particular colour having a consistent effect on attention allocation. In a study that looked at how people look at real world scenes, Frey et al., (2011) found

that colour contrast played the largest role in attracting participants' overt attention in rainforest scenes. This was because the participants' eyes were initially drawn to red objects in a predominantly green scene, though when the colours were artificially reversed, participants' eyes were drawn toward the green colour. What this study suggests is that the novelty of a colour in a scene affects attention, rather than one particular colour being more effective at capturing attention. This is supported by Liu et al. (2011), who observe that attention capturing objects are less likely to contain colours that are distributed widely throughout an image.

Bearing these studies in mind, the data suggests that particular colours are not more effective at capturing attention than others; rather it is the contrast between colours that is significant. For this reason, the experiment reported here will ensure that the colour assigned to objects is equally contrastive to the background of the scene in which it appears. It will also ensure that a particular colour is not in conflict with the real world knowledge of the typical colour associated with that object in that scene. This is achieved by either assigning colours to objects that are typically associated with them (e.g. a yellow lion on a green background), or that the relevant objects in a scene are assigned a similar colour against a contrastive colour background (e.g. grey aeroplanes and grey luggage against a white background). In this way, any attention capturing effect of colour contrast is diminished.

5.1.3. Novelty and surprise

Surprise is one of many emotional reactions that result from the effect that perceived stimuli can have on an experiencer. Surprise is usually thought to be caused by data that is new and unexpected (Meyer et al., 1997) that is, stimuli whose presence is in conflict with a particular cognitive schema associated with a particular event. It results when the perception of new and unexpected information cannot be easily assimilated into an experiencer's expectations of an event, and this has behavioural consequences (Meyer et al., 1991). What this means is that surprise is caused by cognitive appraisal processes that are triggered in response to unexpected variables (Reisenzein et al., 1996). It is intentional and object-driven, in that when one is surprised, one is surprised about something. Something is unexpected when it does not fit with a preconception about how the event should play out and how its participants should be and behave as events progress. This is based on the idea that humans have organised knowledge structures in their memory that represent concepts (schemata) such as situations, objects, events, and actions at various abstract levels (e.g. Schutzwöhl, 1998) whose central function is to facilitate the comprehension of current input, and to predict future events (Rumelhart and Ortony, 1977). Surprise results from the perception of variables that are discrepant

with a particular schema which the experiencer has stored in his memory. This discrepancy causes a reallocation of attentional resources. Schützwohl (1998) found that participants redirected their attention to a discrepant condition, whilst neglecting a schema-congruent condition; the refocusing of attention occurred irrespective of the strength of the discrepant schema. It is well documented that this emotional state can have an effect on the language of a speaker (e.g. Colston and Keller, 1998; Gussenhoven, 1999; DeLancey, 2001; Peterson, 2013). In the current experiment, the objects used in the images will be congruent with the backdrop in which they appear (e.g. a lion in a jungle scene, aeroplanes on a runway scene, a seal in a coastal scene). In this way the experiment excludes unexpected stimuli and the subsequent effect of surprise.

The last property to be discussed in this section on variables that interact with visual attention is Animacy.

5.1.4. Animacy and visual attention

Objects can be animate (e.g. human) and inanimate (e.g. luggage). Animacy is also a property that can be encoded in linguistic expressions. This feature provides a bridge in our discussion about the possible features that may impact on the experimental design in this thesis as it is also a feature of the linguistic context. This section will focus on its non-linguistic effect. The linguistic effect of animacy is the subject of the subsequent section. When viewing natural scenes, attention is automatically drawn to animate agents such as people and animals, relative to inanimate objects such as vehicles and plants, even while carefully controlling for lower-level stimulus differences (New, Cosmides, and Tooby 2007). Kirchner and Thorpe (2006) found that people initiate quicker eye movements toward pictures of animals rather than pictures of other objects. Individuals tend to look longer at animate than inanimate objects (Yang et al., 2012). Animate objects tend to be located more quickly than inanimate objects (Jackson & Calvillo, 2013), and animate motion is detected more quickly than inanimate motion (Pratt, Radulescu, Guo, and Abrams, 2010). Evidence supports the importance of attention to animate objects. New, Cosmides and Tooby (2007) propose the animate-monitoring hypothesis, which posits that animate stimuli, due to their importance in humans' ancestral hunter-gatherer environments, may be processed differently than inanimate stimuli. This suggests that the attention capturing capability of animate objects has an evolutionary base. We were more likely to survive if we attended to animate objects in our ancestral environments (Jackson & Calvillo, 2013). Jackson & Calvillo (2014) conducted a change-blindness study on 200 university students. Participants were instructed that they would briefly see a set of words, and that one of the words would be the

name of a colour. They were instructed to search for the colour name and write it down after the words disappeared. In the third test trial, an unexpected object appeared, simultaneously with the words, which depicted either an animate or an inanimate entity. Jackson & Calvillo (2014) found that participants were more likely to notice the unexpected image if that image depicted an animate entity rather than an inanimate one. This occurred even under a high perceptual load. This cannot be attributed to novelty or surprise of the stimulus or one would expect that unexpected animate and inanimate pictures would be noticed with equal frequency. These studies strongly suggest that inanimate and animate entities interact with attention capture to different degrees. This means that in order to mitigate any effect of visual animacy the current experiment balances animacy so that either both object referents are animate or both object referents are inanimate. As indicated above, animacy is a category that also has a linguistic import.

Now a set of variables of the visual context have been given in order to demonstrate which further factors need to be controlled for in our experimental design. This means that all the factors that are considered to be important to balance for have been discussed. We can now proceed with the picture-sentence matching task which examines the effect of the egocentric perception of distance.

5.2. Method

5.2.1. Participants

49 participants (30 females and 19 males) took part in the experiment. All participants were native speakers of English between the ages of 18 and 64 (Mean age =30) with normal or corrected-to-normal vision. No participant belonged to any vulnerable group, and no participant reported having any neuro-cognitive impairments. The participants consisted of students and non-students, linguists and non-linguists. Participants were paid with a £5 voucher for their participation.

5.2.2. Materials and procedure

The experiment employed a picture-sentence matching task design. Perceived visual proximity was manipulated by presenting pictures of object pairs to participants that contrast in their perceived depth location. The relative left and right orientation of the objects was another potential variable as it has been shown that participants tend to draw simple scenes in a way that reflects the writing direction of their native language. For example, on hearing a sentence and being tasked to draw it,

English participants tend to draw scenes where an item that corresponds to the sentential subject is more likely to be drawn to the left of a picture, and an item that corresponds to the sentential object is more likely to be drawn on the right (cf. Maass and Russo, 2003; Altmann et al., 2006; Román, El Fathi, and Santiago, 2013). Although it has not been shown that the left-right orientation of items in an image affects sentence preferences per se, we did not dismiss this possibility. In order to control for this possible effect, each object occurred in four possible locations: in the foreground and positioned on the left, in the foreground and positioned on the right, in the background and positioned on the left, and in the background and positioned on the right. The objects in a pair had opposing orientations so that when an object was in the foreground and positioned on the left its opposing object was in the background and positioned on the right. When an object was in the background and positioned on the left, its opposing object was in the foreground and positioned on the right. Two sentences accompanied each object pair: a dative construction and a double-object construction for the dative alternation set, and a locative construction and a *with*-variant construction for the spray/load alternation set. The task for participants was to choose the sentence that they thought best matched the scene they were shown. Participants' choice of sentence was measured. The software operated on a *HP Compaq 8200* desktop PC, and the experiment was displayed on an *HP ZR2440W* 24 inch LED Backlit IPS Monitor. Participants also had access to a keyboard used to complete the experiment. The participants sat in a low noise, artificially lit room. The experiment used the *EPrime 2.0* software programme. Data was extracted from *EPrime 2.0* and transferred to *Microsoft excel*, and then coded for statistical analysis using *SPSS 21* statistical software.

Participants were seated centrally, approximately 50cm from the monitor. They were instructed by an on-screen prompt that they would see a series of images accompanied by a sentence-pair marked '1' and '2' which was going to appear after a short delay (1000ms). They were instructed to look at the image and their task was to select as quickly as possible the sentence which best matched what they saw by pressing either '1' or '2' on the keyboard. Participants were told that they could not go back to change an answer, and that they would need to indicate a choice before being taken to the next trial. Pressing the Spacebar started the experiment. A fixation cue appeared in the centre of the screen for 1000 milliseconds. At the top of the screen, a context sentence (e.g. *In this scene Sarah is a schoolgirl*) appeared with the first image immediately below it. After the image had been visible for 1000 milliseconds, a sentence-pair appeared (one target and one non-target) immediately below the image. Participants made their selection and immediately after the numeric key was pressed, they were shown the fixation cue again. This sequence continued until the experiment was complete. The first 10 trials were a practice block after which the software procedure paused and participants were instructed that they now had the opportunity to ask any questions. When the trial block was complete,

a screen appeared thanking them for their participation, and the experiment was terminated. On completion of the experiment, participants completed a short questionnaire. This was to collect the participants' gender, age, highest qualification, occupation (student or non-student), and whether they had any formal linguistic training. Participants were then paid £5 for their participation. No participant took more than 15 minutes to complete the experiment.

5.2.3. Images

The critical images consisted of 24 cartoon-like full colour JPEG files with 72dpi resolution, designed using *Adobe Photoshop* software. There was one main character in the experiment (*Sarah*), who appeared in every trial. She was introduced as an actress, who played a number of different roles. For each role Sarah played, she wore a different costume. Each image depicted a large cartoon thought bubble above the head of Sarah, who was wearing one of six costumes. Within the bubble was one of six simple scenes that were contextually related to the costume that the main character wore. For example, when Sarah played a nurse, the scene depicted a doctor and a patient. The thought bubble took up the upper two-thirds of the screen. The image of Sarah was centrally placed in the bottom third of the image, and took up less than 15% of this space. Each scene was constructed so that the bottom part of the scene in the bubble was perceived as closer to the participant than the top part. This was achieved by manipulating the size of the objects shown. A larger image of the object was used when it appeared at the bottom of the screen and a smaller image when it appeared at the top. Thus, when an object appeared at the bottom, that object was perceived as closer to the participant than an object appearing at the top (Gogel, 1953; Bruno & Cutting, 1988; Murgia and Sharkey, 2009; Champion and Warren, 2010). In addition, the scene provided a contextual backdrop for the object pairs. This backdrop was designed so as to give visual cues to aid in the perception of distance. Cues included other simple scenic objects, whose size was relative to their depicted location. For example in the scene that depicted a lion and a zebra, one tree was included in the background, and the trunk of another tree was depicted in the foreground. Depictions of convergence were also included. This is where lines converge toward a vanishing point, which has been shown to be successful in giving the impression that they extend into the distance (Richards and Miller, 1969). A scene contained one of six object pairs. The members of the pair were positioned in such a way so that they were always in opposing corners of the scene area. Every permutation was used so that each one of the six scenes had four possible variants making 24 scenes in total. This was so the impression of distance was counterbalanced in terms of whether the impression of distance extended upward from the left of the image to the right or upward from right to left. This gave four variants of each scene + object pair (6

x 4), as illustrated in figure 7. Visual salience was thus manipulated by object size within the scene, the position of objects and the orientation of the scene in both image sets. The six scenes with their four variants were further divided into two subsets according to animacy and plurality of the objects depicted. Subset 1 contained pairs of single animate objects; 2 x animal pairs + 1 x human pair. Subset 2 consists of three pairs of inanimate objects. This meant that each subset had three different scenes each with four variants, amounting to 12 trials (3 x 4). This resulted in twenty-four total trials (2 x 3 x 4). Subset 2 was used to accompany the spray/load alternation constructions, whilst subset 1 was used to accompany the dative alternation constructions. Figure 7 illustrates the four possible orientations of object-pairs in a scene. See Appendix 7 for the complete set of critical images.

Figure 7. An example of the four critical trial image variants

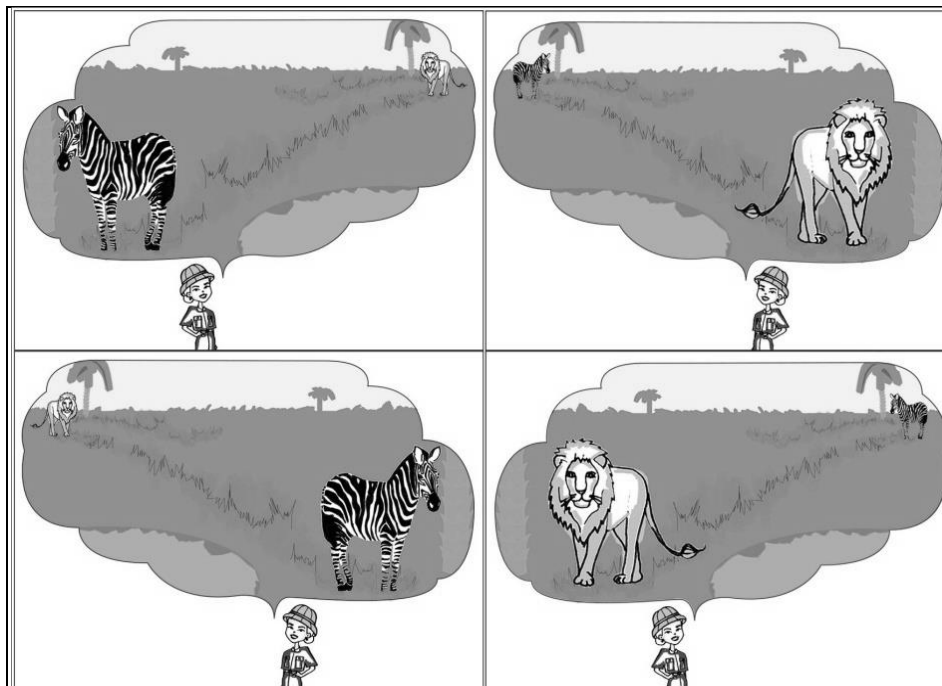

5.2.4. Sentences tested

12 dative alternation pairs and 12 spray/load alternation pairs were presented, which brought the total of critical trials to 24. 30 fillers were included, amounting to 54 trials in total. Prior to the

experiment proper, 10 practice items were presented, which familiarised participants with the procedure. The practice items and the fillers were discarded prior to analysis.

Six double-complement compatible verbs were selected; three that take part in the dative alternation (*show, feed, bring*), and three from the spray/load alternation (*spray, load, pack*). The frequencies for these verbs are given in figure 8 taken from the university of Lancaster “Word Frequency of Written and Spoken English” corpus (<http://ucrel.lancs.ac.uk/bncfreq/flists.html>). The verb *spray* did not appear in this corpus, and is therefore marked as *N/A*. A sentence pair was created for each verb: a locative variant construction and a *with*-variant construction for verbs from the spray/load alternation, and a dative construction and a double-object construction for verbs from the dative alternation. An example from each alternation is given in (316) and (317) respectively.

Figure 8. Frequency list of verbs by lemma: overall occurrences per million

Alternation	Verb	Frequency per Million
Dative	Feed	67
Dative	Show	598
Dative	Bring	439
Spray/Load	Spray	N/A
Spray/Load	Load	22
Spray/Load	Pack	33

- (316) a. Sarah sprayed paint on desks. (*locative variant construction*)
 b. Sarah sprayed desks with paint. (*with-variant construction*)
- (317) a. Sarah showed the seal to the shark. (*dative construction*)
 b. Sarah showed the shark the seal. (*double-object construction*)

Each sentence pair used referring expressions which picked out the object pairs in the corresponding image: full non-modified singular NPs in the dative set (e.g. *the shark*), and bare non-modified plural NPs in the spray/load set (e.g. *desks*). The latter set consisted of two non-count/count noun pairs and one count/count noun pair. Each referring expression pair had been matched for the number of words in the expression. The relative difference in syllable number between the expressions was minimised to no more than one (see figure 9.). In addition each referring pair was also matched in terms of *Givenness* such that neither object appeared in a previous context without the other in its pair, nor was any referent of an expression incompatible with the context of the scene that the sentences described. Data that is unexpected (that is, stimuli whose presence is in conflict with a particular cognitive schema associated with a particular event) cannot be easily assimilated into an experimenter's expectations of an event and this has behavioural consequences (e.g. Meyer et al., 1991; Schützwohl and Borgstedt, 2005), such as interfering with attention allocation (Reisenzein et al., 1996).

Figure 9. Critical trial verbs and their matched referring expressions

Alternation	Verb	NP1	NP2
Dative	feed	the lion	the zebra
Dative	show	the shark	the seal
Dative	bring	the doctor	the patient
Spray/Load	spray	paint	desks
Spray/Load	load	luggage	aeroplanes
Spray/Load	pack	bombs	boxes

In a trial, one sentence in a pair appeared above the other. Their orders were pseudo-randomised so that each participant saw an even number of each sentence type in the first sentence position during the experiment, and this combination was varied across trials and between participants. In order to maintain a balance across conditions and across trials, four pseudo-randomised instantiations of the experiment were created so participants saw a unique combination of sentence order and image orientation.

5.2.5. Fillers and practice items

The practice items also consisted of an image and sentence pair. These served to acclimatise participants to the trials. All participants scored at ceiling on these, which confirmed that the participants understood the task. These were subsequently discarded. Two filler conditions, comprising 30 trials in total each, were used. The first filler condition used the same 24 scenes from the critical trials, but without either the bubble or a depiction of Sarah. The purpose of this was to assess whether the 3d cues in the images made participants perceive objects as being at different distances. This was in addition to the fillers functioning as distractors to the main experiment. An example is shown in figure 10.

Figure 10. An example of four variants of a filler trial

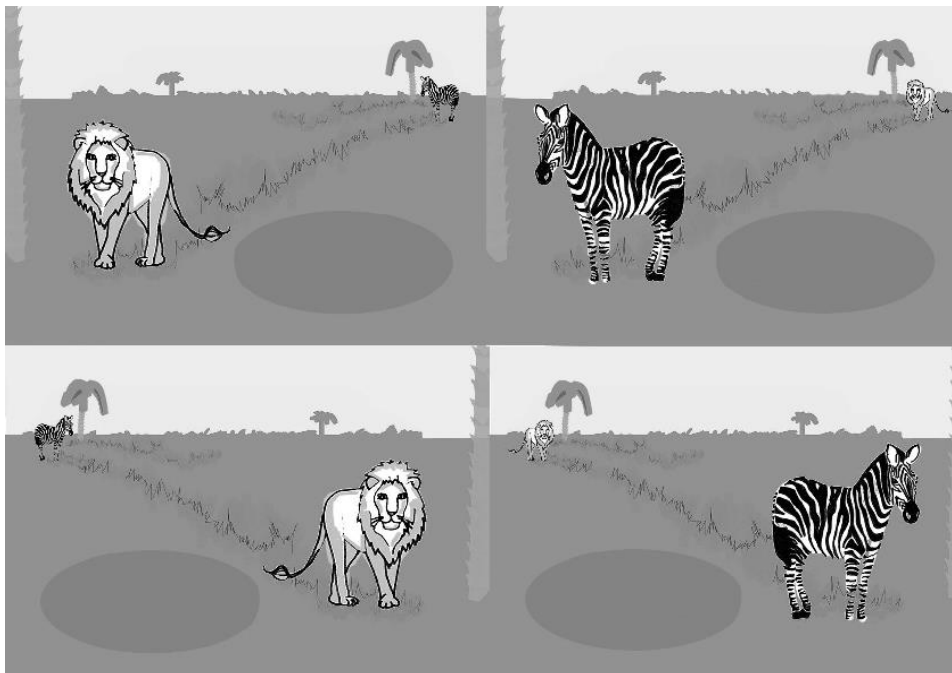

The sentences of this set consisted of statements identifying the location of one of the objects as in (318). The second filler condition used fillers containing pictures of the main character in her different costumes. The sentences in this set were statements identifying the uniform that the character was wearing; one was correct and the other was not, as in (319). All items appeared with a context sentence which had one of the following structures: *In this scene...*, or *In this scene Sarah is an X* (where X corresponds to the costume that Sarah was wearing). The former was used for the filler trials, and the latter for the critical trials.

- (318) a. The lion is nearer than the zebra.
- b. The zebra is on the left.
- (319) a. Sarah is a game keeper.
- b. Sarah is a police woman.

In addition to the trial and filler images, two further images were included as visual cues to aid with the introductory narrative to the experiment. These images only appeared in the introduction stage, before the practice trials. They did not appear at any other time during the experiment.

5.2.6. Results

Data was first scored for a sentence-to-picture response. The data captured the effect of relative object distance. For the *spray/load* alternation, participants' responses were summed according to the number of times the *with*-variant construction was chosen, which gave a 7-point scale, ranging from 0 – 6. For the dative alternation, participants' responses were summed according to the number of times the double-object construction was chosen, which also gave a 7-point scale, ranging from 0 – 6. As we have already established that there is a default preference for the locative construction and the dative construction, comparisons of the *spray/load* alternation focused on whether the total number of *with*-variant construction responses was higher in the NP2 foreground condition than in the NP2 background condition. Similarly, comparisons in the dative alternation focussed on whether the number of double-object construction responses in the NP2 foreground condition was higher than in the NP2 background condition.

Participants were coded according to gender, age, student/non-student, education level, and whether they had undergone any linguistic training. These further participant details can be found in Appendices 4 and 5. In the 24 filler trials, participants' overall accuracy was collected to check the effectiveness of the depth perspective of the images, and to check participants' performance within the experiment.

5.2.6.1. Group comparisons

In the filler sentences, participants achieved a 94% success rate, which indicates that the perception of depth was effectively communicated by the cartoon-like images. I now report on the spray/load constructions first. In the spray/load verb set, it was predicted that participants would choose the *with*-variant construction more often when the visual object that corresponded to the NP2 was in the foreground than when the visual object that corresponded to NP2 was in the background. The median number of *with*-variant construction choices was 3 when the NP2 was in the background and 2 when in the foreground, indicating support for the hypothesis. A Wilcoxon signed ranks test confirmed this difference ($p < 0.001$). Figure 11 shows the distribution of spray/load alternation responses in the NP2 background condition. Figure 12 shows the distribution of spray/load alternation responses in the NP2 foreground condition.

Figure 11. Number and percentage of locative and with-variant responses in condition 1

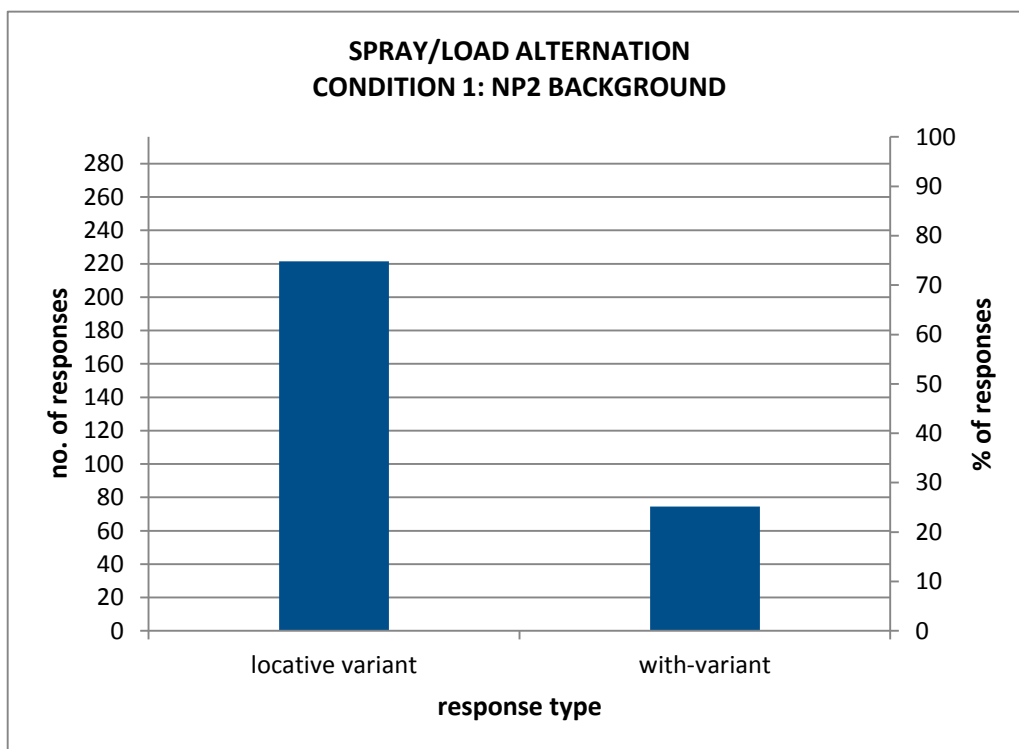
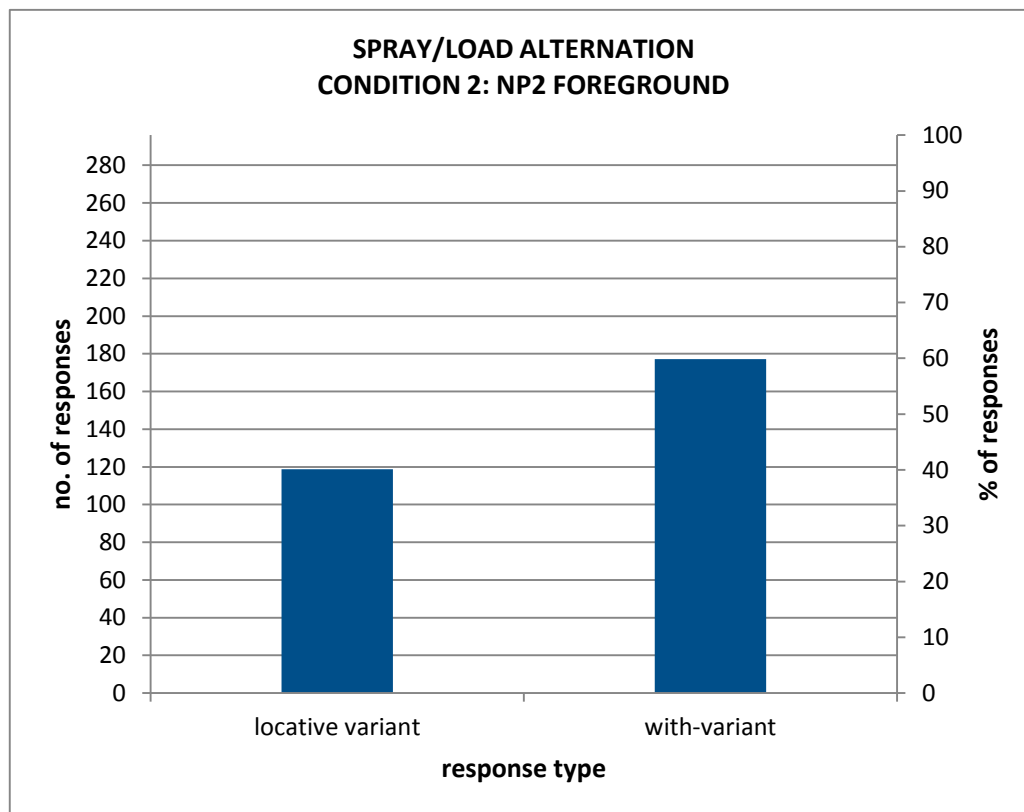
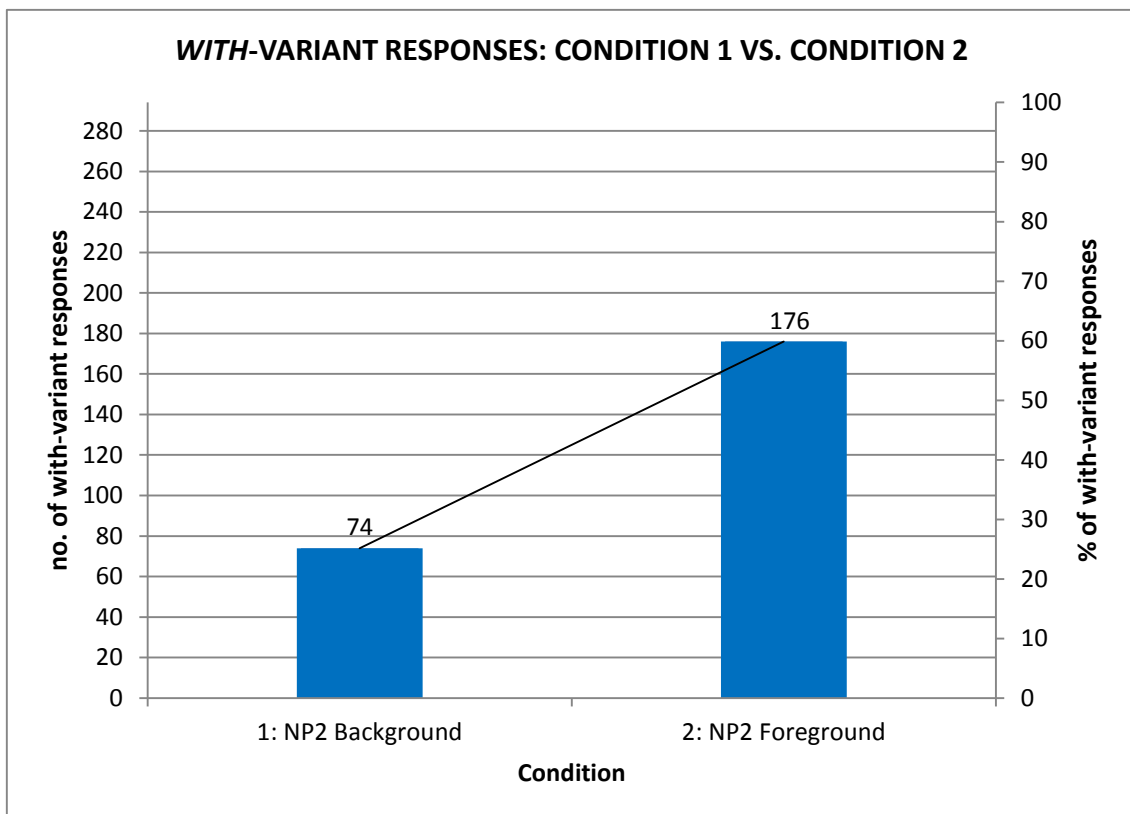

Figure 12. Number and percentage of locative and with-variant responses from condition 2



As we can see from figure 11, participants chose mostly locative variant constructions in the NP2 background condition. The *with-variant* construction totalled 25.2% of the total responses. Contrastingly, in the NP2 foreground condition (condition 2), participants chose the *with-variant* construction 59.9% of the time, as can be seen in figure 12. When the number of *with-variant* construction responses is compared across the two conditions, we see that a marked difference in *with-variant* construction preference between the conditions. The comparison between the number of *with-variant* responses in condition 1 and 2 can be seen in figure 13.

Figure 13. Comparison of with-variant responses from condition 1 and 2



In the dative verb set, participants were more likely to select a double-object construction when the object that corresponded to NP2 was in the foreground (median = 3) than when the object that corresponded to NP2 was in the background (median = 2). This was also a significant difference as confirmed by a Wilcoxon signed rank test ($p < 0.001$). Figure 14 shows the distribution of dative alternation responses in the NP2 background condition. Figure 15 presents the distribution of dative alternation responses in the NP2 foreground condition.

Figure 14. Number and percentage of dative and double-object construction responses from condition 1

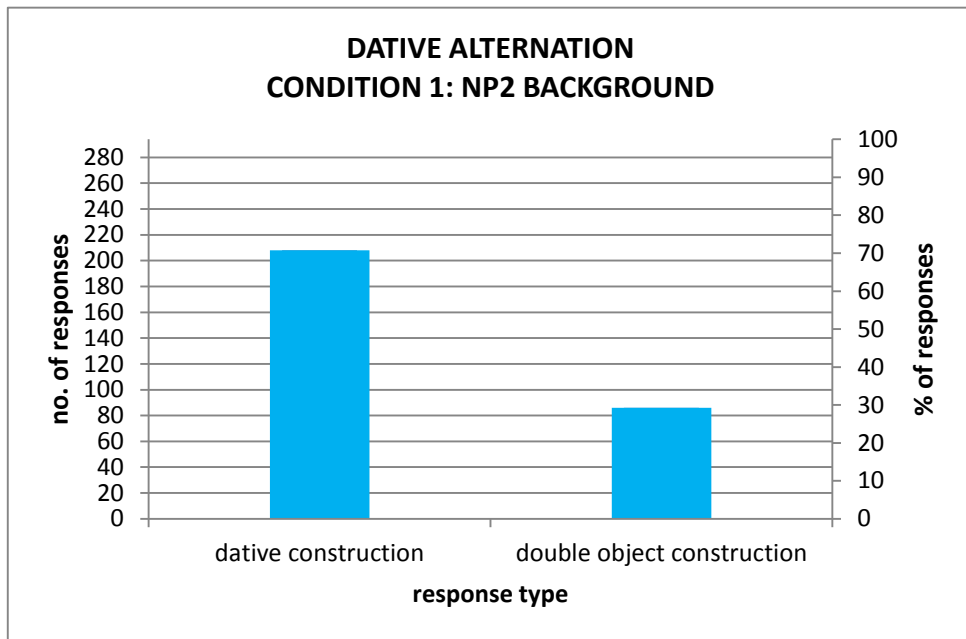
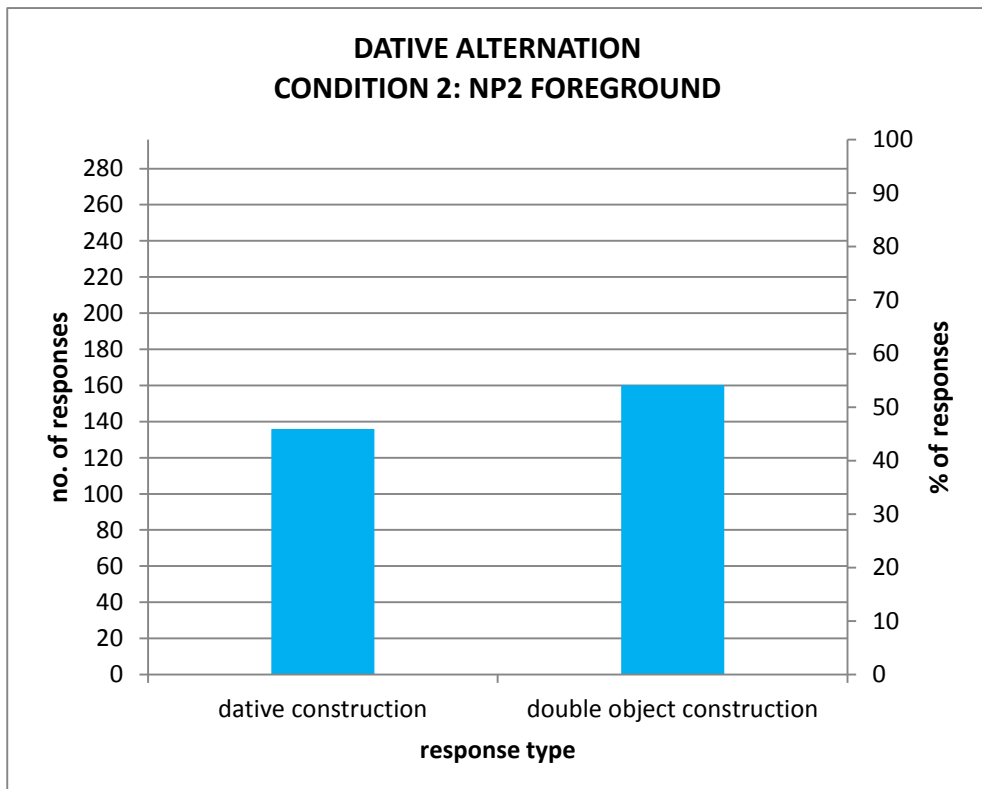
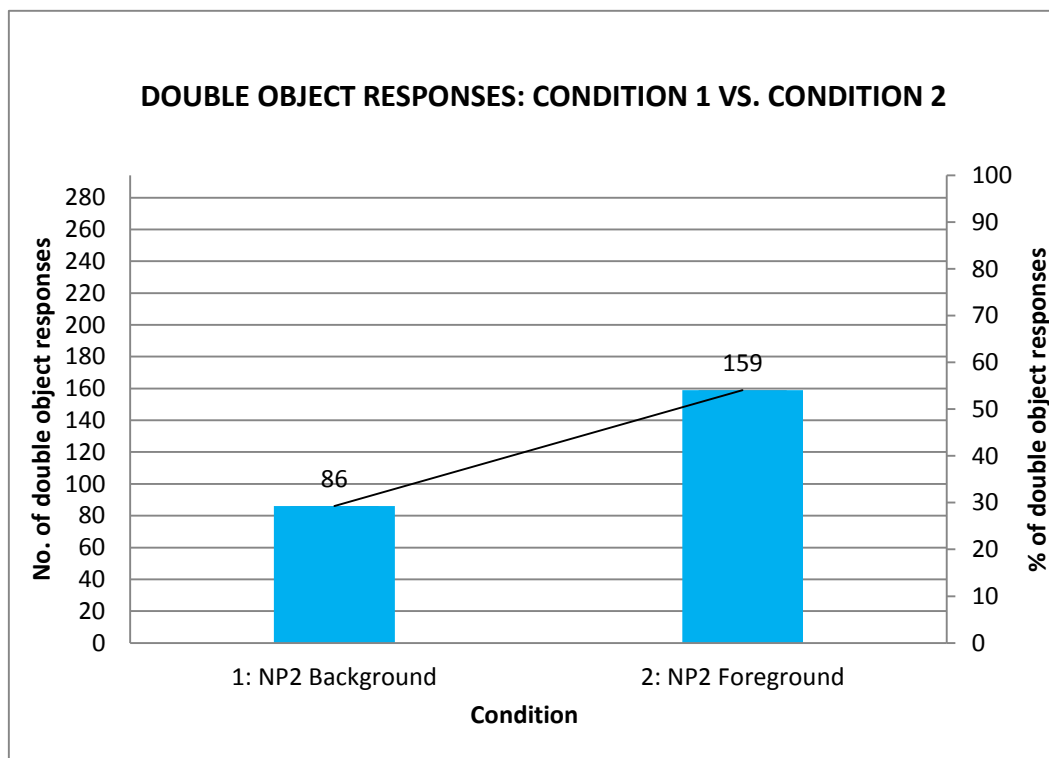

Figure 15. Number and percentage of dative and double-object construction responses from condition 2



As we can see from figure 14, participants chose mostly dative constructions in the NP2 background condition. The double-object construction was chosen 29.3% of the time. Contrastingly, in the NP2 foreground condition (condition 2), participants selected the double-object construction 54.1% of the time, as can be seen in figure 15. When the number of double-object responses is compared across the two conditions, we see a marked difference in double-object construction preference between the conditions. The comparison between the number of double-object responses in condition 1 and 2 can be seen in figure 16.

Figure 16. Comparison of double-object responses from condition 1 and 2



A paired samples t-test shows that the preference for the target construction in condition 2 is not influenced by the left/right orientation of the NP2 in the spray/load alternation ($t(48) = -9.24$, $p = 0.37$), but an effect is seen in the dative alternation ($t(48) = -2.69$, $p = 0.01$). Participants preferred the double-object construction more when the NP2 was on the right. This is not as predicted by Maass and Russo (2003), Altmann et al. (2006), or Román, El Fathi, and Santiago (2013).

5.2.7.2. Individual and between group comparisons

Only the overall preference from individuals for condition 2 is discussed. The preferences in condition 1 are only of concern in terms of their serving as a point of comparison for the data in condition 2. Firstly for the spray/load alternation set in condition 2, 24 out of 49 participants (48.98%) patterned in the direction of an overall preference ($N > 3$) for a *with*-variant construction in the NP2 foreground condition. 11 (22.45%) showed no overall preference and 14 (28.57%) exhibited an overall preference the locative variant construction in this condition. This is illustrated in figure 17.

Figure 17. Total number and percentage of overall individual preferences in condition 2 for the spray/load alternation

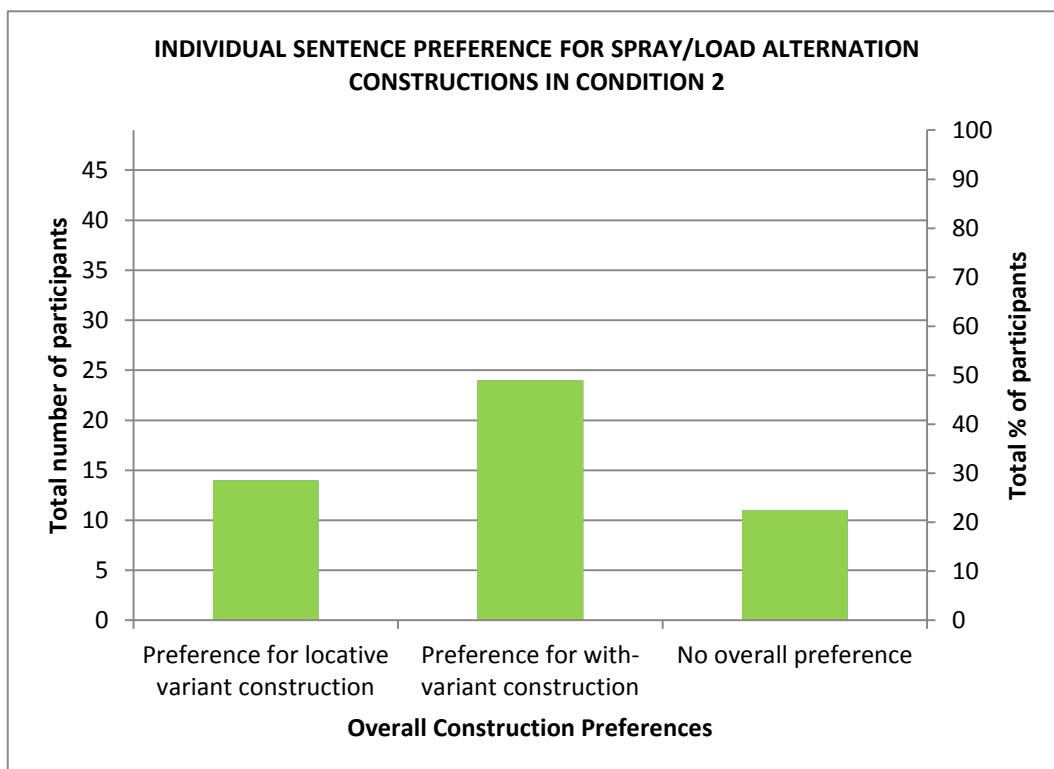

In the dative alternation set in condition 2, 22 out of 49 participants (44.9%) patterned in the direction of an overall preference ($N > 3$) for a double-object construction in the NP2 foreground condition. 11 (22.45%) showed no overall preference and 16 (32.65%) exhibited an overall preference the dative construction in this condition. This is illustrated in figure 18.

Figure 18. Total number and percentage of overall individual preferences in condition 2 for the dative alternation

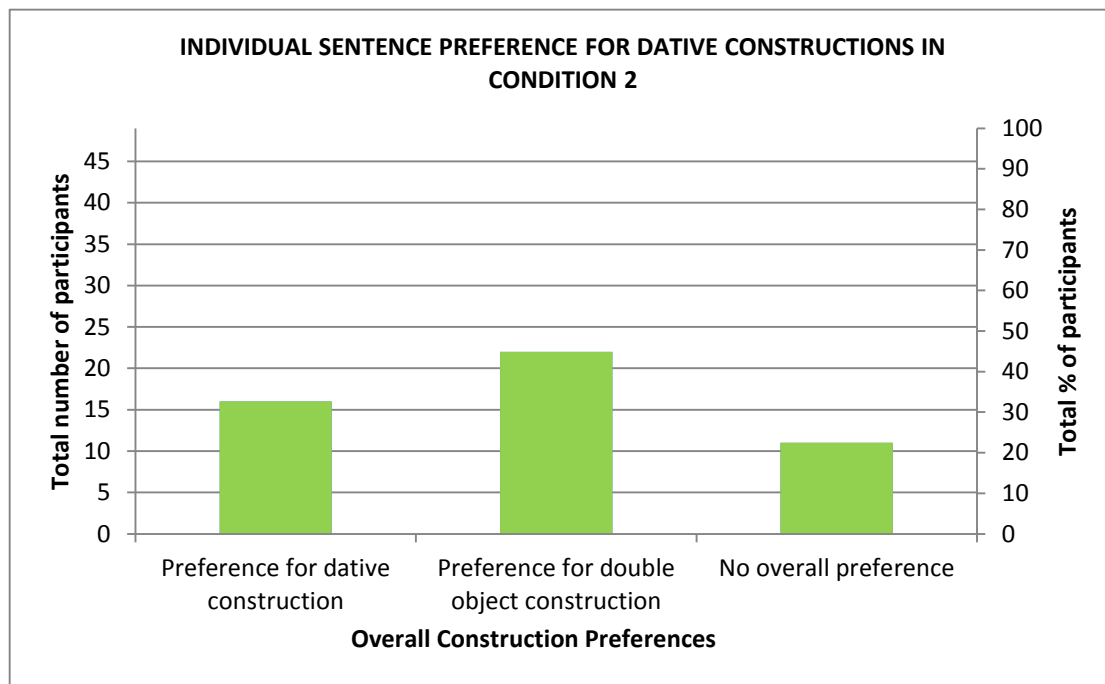

In condition 2, a significant effect is seen at a group level for both the spray/load alternation and the dative alternation. On an individual level the amount of individuals who exhibited an overall preference for a *with*-variant construction from the spray/load alternation and a double-object construction from the dative alternation is not as pronounced as expected. More individuals did however exhibit an overall preference for the target constructions in condition 2 than those that preferred the non-target overall or showed no preference. However, the individuals that opted for the target constructions did not form an overall majority. 15 out of 49 participants (30.61%) showed a preference for both the *with*-variant construction and the double-object construction. Two participants (4.08%) showed no overall preference for any construction, and 8 out of 49 participants (16.33%) showed an overall preference for the non-target constructions in condition 2. Only 2 participants showed no preference for either a dative or a double-object construction in either condition, and 2 participants showed no preference for either a locative variant or a *with*-variant construction in either condition. No individual showed no preference in both verb sets.

In the dative alternation, of the 49 participants, 31 (63.27%) exhibited a positive increase in the number of double-object construction responses in condition 2 compared to condition 1, 11 participants (22.45%) showed no change and 7 (14.28%) showed a reduction in double-object

responses in condition 2. In the spray/load alternation, 33 participants (67.35%) exhibited a positive increase in the number of *with*-variant responses in condition 2 compared to condition 1, 10 (20.41%) showed no change, and 6 (12.24%) showed a reduction in *with*-variant responses in condition 2 compared to condition 1. No Participant showed a decrease in both a double-object construction and a *with*-variant construction in condition 2 compared to condition 1, and only 3 (6.12%) showed no change in the number of target constructions for both verb groups.

Results revealed no group effects for the preference for a *with*-variant construction. A one-way ANOVA showed no significance for age ($F(4,44) = 0.659$, $p = 0.62$), education ($F(3,45) = 0.173$, $p = 0.9$), or which instantiation of the experiment was seen ($F(3,45) = 0.630$, $p = 0.6$). An independent samples T-test found no difference for gender ($t(47) = 1.607$, $p = 0.12$) or previous linguistic training ($t(47) = -0.182$, $p = 0.86$).

There were also no group effects on the preference for a double-object construction. A one-way ANOVA showed no significance for age ($F(4,44) = 0.207$, $p = 0.93$), education ($F(3,45) = 0.413$, $p = 0.75$), or which instantiation of the experiment was seen ($F(3,45) = 0.309$, $p = 0.82$). An independent samples T-test found no difference for gender ($t(47) = 1.8$, $p = 0.08$) or previous linguistic training ($t(47) = -0.552$, $p = 0.58$).

5.8. Discussion

The purpose of this study was to measure the effect of the egocentric perception of distance on sentence preference in the spray/load and dative alternations. In our initial study we established a preference for the locative construction and the dative construction in the absence of any contextual cues. In the current one, we showed that this preference can be significantly diminished by the presence of a visual context, when the sentences are used to describe the visual scene. The study showed that the relative proximity of the NP2 referent relative to the NP1 referent impacted on this preference. Overall, participants preferred the double-object construction, and the *with*-variant construction in this context, whereas they did not exhibit this preference when the NP1 referent was in the foreground. This effect of visual context was not felt more in any particular in-sample group, and the effect did not react with the left/right orientation of the foreground object. This suggests that this feature of the visual context can be attributed to a generalised effect observed across the sample population. A large proportion of the sample were affected to some degree by the egocentric perception of distance. This study supports the findings of Mazzo, Turatto, Umiltà, (2005) as the presence of an object on a front plane captures attention more effectively than an object that exists

on a back plane. This occurred in a visual scene of simple geometric shapes. Our findings show that this conclusion can be extended to pictorial depictions of real world scenes. The findings of this experiment also build on those in Vogels, Krahmer, and Maes (2013), presented in (2.18). In that experiment they showed that distance information (cued by partially occluding one referent with another) affected the production of a transitive sentence. The referent in the foreground was more likely to be used as the sentential subject. The findings in our experiment show that this sensitivity to distance information is relevant to the ordering of objects in the double- complement sentences in this study that are used to describe the scene. Overall, we provided supporting evidence for the idea that attention influences word order preferences. This is important as this motivation of word order variation has implications for the accounts of the spray/load and dative alternations presented here. These implications are discussed in chapter 6.

Chapter 6. The analysis of the spray/load and dative alternations

6.1 Introduction

The purpose of this chapter is to bring together all of the aspects discussed so far in order to see what progress has been made in our understanding of the spray/load alternation. In the preceding chapters, a number of different approaches have been discussed, which lay emphasis on different aspects of the spray/load construction. These have laid the foundation for a comprehensive account of the spray/load alternation. Some important arguments have been put forward. First I suggested that the syntactic account of the spray/load alternation can be unified with that of the dative alternation. This has moved forward the discussion about the similarity of the structures in the spray/load alternation and the dative alternation as claimed in Speas (1990) and Larson (1990; 2014) considerably, albeit from a different view of the syntax. Secondly, I argued that the semantic account of the spray/load alternation from Construction Grammar cannot account for the preferences for one variant over the other. Thirdly, I claimed that it is information processing that it is a primary motivation for the varying word orders between the variants of the spray/load alternation and the dative alternation. I have combined established approaches that deal specifically with thematic structure, syntactic structure, and the effect of attention on information processing. I propose that these theories are indeed compatible with each other in that they each account adequately for the part of language that they address as well as providing a compatible interface for their integration. The compatibility that I claim between the approaches rests on the view of the syntax of Janke and Neeleman (2012) that I have discussed. It is by reference to the dual structures of this approach that the formality of thematic structure and the dynamic flexibility of information processing can be integrated. I now provide a shortened overview of what has been discussed thus far and how this relates to the double-complement structures in this thesis; particularly the spray/load alternation. In (6.2), I summarise the key points of the approaches discussed in chapter 2 with the tests from chapter 3 and the experimental evidence from chapters 4 and 5. This will remind the reader of all of the aspects that contribute to the generation of a spray/load sentence. Section (6.3) provides the analysis of the spray/load alternation. I show how the feature clusters of the Theta System and the effect of attention feed into the syntax. I argue that the structures in Janke and Neeleman (2012) provide the correct structures to realise this input to produce one of the structures from the spray/load alternation. In (6.4), I discuss an important aspect as yet unaccounted for in this document: the distinction between Merge and linear assembly. In (6.5) we look at some outstanding questions and some future avenues

for research. In particular I focus on the differences between the double-object construction and the *with*-variant construction in respect to the preposition *with*; the latter appears with an overt preposition and the former does not. An interesting line of enquiry is the existence of a null preposition introducing the NP1 in the double-object construction.

6.2. Key points

In 2.1, thematic structure was discussed in respect to the account of the Theta System of Reinhart (2000; 2002). In this approach, the theta system is the central component of the mental system that enables the interface between the system of concepts and the computational system. It contains coded concepts with features that define the basic theta-relations of verb entries (causality and sentience), and a set of marking procedures that prepare verbal material for the syntax. The coding of theta relations is determined by a set of binary features (+/-c (cause change) and +/-m (mental state)) and it is only these values that are visible to the syntax. It was argued that a semantic label such as *agent* is the result of inferences based on the value of its thematic feature cluster in a particular context. Similarly, the semantic labels of goal, recipient, possessor, and location were all said to be inferences licensed by the feature cluster [-c]. This cluster allows inferences of both animacy and inanimacy based on the underspecification of the /m feature. The consequence of this is that the feature cluster of the NP2 of a dative construction is not distinguishable from the NP2 of the locative variant construction as the former is generally associated with recipients (which are animate) and the latter with locative goals (which are inanimate). The [-c] cluster of the NP2 also does not distinguish between the fine grained distinction between a recipient and a possessor as it does not contain the detailed semantic information that can determine the difference between them. This means that the NP2 of the dative construction is not distinguishable from the NP2 of the double-object construction in any way that is relevant to the syntax; they both have the same feature cluster. A first pass at a hierarchy of feature clusters was also given. It was argued that in the hierarchy the cluster usually inferred to be a *theme* ([-c -m] appears lower in the hierarchy than the [-c] cluster. This is based on the assumption that the more negative values explicitly profiled in a cluster, the lower on the hierarchy it will appear.

In (2.12), a model of the syntax of double-complement structures was encountered. This model proposes that a double-complement verb phrase is characterised by one of two distinct and independent syntactic structures: an ascending and a descending structure. The ascending structure is based on the traditional structure in Chomsky (1981), and the descending structure is based on the

double-object structure of Larson (1988). However the descending structure differed from Larson's in that its arguments are not derived from an underlying position and are in fact generated in the position in which they appear. The only derived movement in this approach is by the verb which moves into a position to license the accusative case of the NP2 argument. Each structure was shown to only account for a portion of the data independently. Only by reference to two independently generated structures could the data on scope, the distribution of floating quantifiers, and constituency be captured as argued in J and N. The binding data was accounted for by appeal to the General Pattern of Anaphoric Dependency proposed by Williams (1997). It was proposed that both of the structures of a double-complement alternation are in competition. The selection of a particular structure is primarily regulated by a condition of economy. If two structures are characterised by identical hierarchical relations then the one with the fewest movements (the ascending structure) is selected unless the less economical structure (the descending structure) is needed to rescue an ill-formed structure. Particularly this is the requirement to license the case feature of the NP2 argument by left-adjacency of the verb. Importantly, this account made no claim as to why the NP2 argument appeared in different linear positions (to the left of NP1 in the double-object construction, and to the right of NP1 in the dative construction). Only the hierarchical relations between the object NPs was discussed.

Section (2.15) went on to the Construction Grammar account of the spray/load alternation. This approach views the components of a sentence as a verb and an independent construction. The verb which has a minimally specified lexical entry does not project a structure; a sentence is formed by the integration of a verb into a construction frame that has a generalised meaning and exists as an independent entry in the lexicon. The meaning associated with a particular construction is independent (although compatible) with the meaning of a verb with which it can appear. For example, the verb *load* describes a loading event that involves a loader, a loaded theme and a container which is profiled in the verb's lexical entry, whereas the locative variant construction denotes a cause-motion event involving a cause, a theme, and a path. In the construction, these roles are represented as empty slots that can be filled by (compatible) roles profiled by the verb. At least one verb role must fuse with a role of the construction. The fusion of verb roles and construction roles generates an interpretation of an event in which a loader causes a theme to move toward the location of a container, with no implication that the change of location of the theme is completed. The compatibility between a verb and a construction is licensed either by the verb and construction sharing a common semantic feature or by metaphorical extension in the sense of Lakoff (1993) such as the change-of-state as change-of-location metaphor. In order to prevent the over generation of constructions, a number of construction-specific semantic constraints are stipulated. Constructions are also argued to be associated with a limited number of semantic extensions, which means that a construction is

polysemous. In the dative alternation, the dative construction is associated with a cause-motion meaning, and the double-object construction is associated with a cause-to-receive meaning. In the spray/load alternation, the locative variant construction is also associated with a cause-motion meaning which means that it is identical to the dative construction except by way of the different prepositions introducing the locative argument. The *with*-variant construction is a special case. It is one of the few examples of a compositional structure. The variant is claimed to be a change-of-state construction (a standard transitive sentence) with the addition of an obligatory adjunct that has an interpretation in which this argument is instrumental to the event. A number of problems for this approach have been highlighted. It was demonstrated that Construction Grammar cannot account for exceptional cases in which, for example, a double-object construction is not associated with a cause-to-receive meaning (e.g. *Sam bet John fifty pounds*). The meaning claimed to be denoted by the construction is only a possible entailment of the sentence and therefore falls under the remit of pragmatics rather than being semantic in nature; they are inferences based on contextual constraints. Additionally, the argument for the polysemy of constructions was shown to be weak. Polysemous interpretations are difficult to separate from the meaning of the verbs that a claim for polysemous constructions is proposed to account for. Moreover, the Construction Grammar analysis of the *with*-variant construction is shown to be problematic. The adjunct classification of the *with*-PP falls short as its behaviour does not resemble other adjunct phrases. This was also the case for the semantic interpretation of the *with*-PP as an instrument as interpretations beyond the one specified are possible. The multiple role interpretations associated with this argument are the result of the linking to the [-m] thematic cluster. A reformulation of the Feature Cluster Hierarchy has been proposed and the Construction Grammar approach is rejected.

In (2.18), the effect of context was presented. Here it is claimed that the word order of arguments interacts with the way we process information constrained by the limited capacity of Working Memory. This is regulated by attention which was defined as the allocation of processing resources to some piece of information. This process occurs at the expense of the processing of other available information. It has also been described as proceeding in a serial fashion from one item of information to another. The serial order is determined by particular features of objects in the context; as the features capture attention they are processed. It has been argued that in order to maintain an efficient processing system, Working Memory operates on the principle that information is discharged as soon as it is processed. This means that the serial order of the processing of objects corresponds to the linear order of objects in a sentence that describes that scene. In other words, an item to be reported which is currently the focus of attention tends to trigger the generation of syntactic structures that allow for the early production of this material. This effect on attention allocation by the egocentric

perception of distance was discussed. This feature of the visual context has as yet been untested on preferences for a variant in the spray/load and dative alternations. It is defined as the perception of distance from an observer to an object along a depth axis that linearly extends away from the observer's field of vision. If two objects vary in their egocentric perception of distance, the one that is closer is more likely to be referred to as the subject of a transitive sentence, whereas the one that is further away is more likely to be referred to as the object of the sentence (Vogels, Krahmer and Maes, 2013). It was claimed that this effect is not exclusive to the linear order of transitive constructions but also affects the linear order of object arguments in the spray/load and dative alternations.

In chapter 3, a range of standard syntactic tests that are sensitive to syntactic structure have been presented in order to determine which structures of the dative alternation correspond to the structures of the locative variant and *with*-variant constructions. The chapter began by arguing that the structure of the locative variant could be assimilated with the dative construction, and that the *with*-variant construction can be compared to the double-object construction. This is because the relative hierarchy between the [-m] and [-c] clusters in spray/load verbs is the same as that between the [-c -m] and [-c] clusters of dative verbs. The [-c] cluster occurs higher than both [-c -m] and [-m] clusters. In both alternations the [-c] cluster is associated with the NP2 object. The variants are then matched according to the position of the [-c] cluster; to the left of NP1 for the double-object and *with*-variant constructions, and to the right in the dative and locative-variant constructions. It has been shown that the locative variant exhibits parallel behaviour to the dative construction, and the *with*-variant construction exhibits parallel behaviour to the double-object construction in respect to scope interpretation, the formation of passives, the formation of deverbal nominals, sluicing ellipsis, *do so* anaphora, and the licensing of floating quantifiers. The locative variant also exhibits parallel behaviour to the dative construction in respect to the formation of unaccusative sentences, synthetic compounds, the modification of verb particle constructions with *right*, *wh*-movement, *tough* movement, and relativisation. However this parallelism is not mirrored between the *with*-variant construction and the double-object construction. This remains an unresolved issue.

Chapter 4 presented the first experiment. Its intention was to establish a baseline preference for one of the variants from the spray/load alternation and one of the variants of the dative alternation in a neutral context. A number of features that were deemed important to the experimental design were considered. The effect of linguistic animacy, phonological weight of referring expressions, grammatical number, and definiteness indicated by definite or indefinite articles was presented. These variables were controlled for in the experimental design. The results show that participants significantly prefer the dative construction over the double-object construction and the locative variant construction over

the *with*-variant construction. These are argued to be important findings for several reasons. Firstly, they give empirical support to the claim that the dative construction is the less complex of the two constructions in the dative alternation as participants are argued to be constrained by economy conditions. It is assumed that in a neutral context, nothing interferes with the selection of the more basic structure. Secondly, it gives support to the claim that the locative-variant construction is the same as the dative construction. This is because both structures are the most economical of their respective alternation. This means the comparative analysis of the constructions in chapter 3 is on the right track. The result of the experiment also gives support to the claim that the structure of the *with*-variant construction is distinct from the structure of the dative construction with the former being more complex than the latter. If this was not the case then one would have expected to see a preference for a construction from the spray/load alternation to be no greater than chance. It has also been argued that the significant preference for one of the constructions from an alternation brings into question the validity of the Construction Grammar approach. It is difficult to see how a cause-to-receive construction (our double-object construction) is not derived from a cause-motion event. If a double-complement verb has a default association with a cause-motion event then a cause-to-receive construction must also have the availability of a cause-motion interpretation. Based on the evidence, the same problem exists for the distinctiveness of the change-of-state interpretation of the *with*-variant construction, in which case the uniqueness of a form-meaning correspondence for a construction from an alternation is not clear.

In chapter 5 the experiment that tested the effect of the egocentric perception of distance has been presented. It has been shown that by controlling for the contextual variables that were accounted for in the experiment in chapter 4 as well as those found in the visual context (colour, novelty and surprise, and animacy) participants' preferences for a construction from the dative alternation and the spray/load alternation can be significantly altered from the baseline preference established in chapter 4. Participants are more likely to select a *with*-variant construction from the spray/load alternation and a double-object construction from the dative alternation when the NP2 argument corresponds to a referent in a visual scene that is perceived to be closer to the observer than a referent that corresponds to the NP1 argument. This is because the presence of an item on a front plane captures attention more effectively than an item that exists on a back plane. This evidence provides support for my hypothesis that the order of the serial processing of objects in a visual scene affects VP word order preferences in a double-complement sentence. Of two items in a visual scene, the item that captures attention first and hence is processed first in respect to the other item is more likely to have a referring expression which appears before the referring expression that corresponds to the other item due to the sensitivity of attention to distance information. The Construction

Grammar approach has nothing to say about this, and is unable to account for this non semantic preference.

6.3. The analysis of the spray/load alternation

As we saw in (2.15) the Construction Grammar approach has been the dominant analysis of the spray/load alternation. On this view, each of the variants of an alternation are characterised by a distinct meaning, as seen in (2.16). Throughout this thesis I have questioned the efficacy of this theory. The experimental data presented in this thesis also impacts on its validity. The preference for one of the constructions from the alternation can be affected by a contextual variable that does not alter the event semantics. This implies that the event semantics of a variant is not distinct from the other as claimed in Construction Grammar. In the experiment in chapter 5, nothing had been altered in the visual images presented to participants apart from the distance information of the objects. There is no difference that motivates a difference in the semantics of the event, yet the preference for a structure from an alternation is significantly affected. Moreover, the significant preference for the dative and locative variant constructions in a neutral context in chapter 4 implies that there is a default interpretation of a double-complement event which involves dative and spray/load verbs - one which involves the causal movement of an object along a path toward some goal. The claim here is that this meaning is the only one available to the generation of a spray/load or dative sentence. This can only be the case if it is the verb that carries the event meaning rather than the construction; as such the semantic account proposed in Construction Grammar is rejected as it cannot effectively capture the motivation for the availability of the variants in the spray/load or dative alternations. The experiments indicate that, given the availability of two variants why one variant is preferred over another. It suggests that a preference for a variant is not based upon a difference in semantics but rather a difference in contextual information that is not semantic in nature; the relative distance of participants does not change the kind of event that is being described. This preference cannot then be a result of a different thematic coding. If there is a consistency of profiled feature clusters for a locative variant construction and a *with*-variant construction then the trigger for these structures cannot be due to the existence of a homophonous verb with a different sense. A difference in the event semantics of a spray/load event denoted by a different verb sense would involve the profiling of a different set of participant roles. I therefore reject a semantic account that distinguishes each variant by a difference in meaning in favour of the view that the event meaning associated with the variants is the same (e.g. Larson, 1988; Bresnan et al., 2007). A core meaning can only be available to an alternation if the participant roles that take part in the event denoted by the verb are the same for each of the variants.

This is what is proposed by the analysis of the Theta System discussed in chapter 2. A dative verb is argued to consistently project a [-c -m] and a [-c] cluster. The former is usually inferred to be a theme participant and the latter as a goal. A spray/load verb is argued to consistently project a [-m] and a [-c] cluster. The [-m] cluster can also be inferred as a theme although other inferences are available. The availability of multiple inferences associated with spray/load or dative verbs is a result of the underspecificity of a verb's feature clusters. The possible set of interpretations is more restrictive when both features of a cluster are specified. This leads naturally to a prediction that spray/load verbs are subject to more variability in event meaning than dative verbs, as the former has two underspecified profiled clusters and the latter has only one (abstracting away from the feature cluster associated with the causal participant). This means the set of possible inferences as to the roles of participants in an event is larger for spray/load verbs than dative verbs. There is a greater acceptance in the literature that variability in meaning exists between the variants that denote a spray/load event than exists between the variants that denote a dative event. This is a likely outcome of the underspecificity of the thematic clusters involved in a spray/load event. So what this ultimately means for the analysis is that an event meaning of a spray/load and dative verb is contained in the lexical specification of the verb and its profiled thematic clusters and differences in inferences about the structure of the event is amplified by the underspecification of clusters.

It was proposed in (2.9) that clusters are represented in a formal hierarchy. This is uncontroversial as we saw that a thematic hierarchy is assumed by many accounts, although the form of the hierarchy is disputed. The cluster hierarchy I propose is repeated below in (320).

(320) *The Feature Cluster Hierarchy (revised)*

[+c +m], [+c]/[+m], [+c -m]/[-c +m], [-c], [-c -m], [-m]

What I claim is that the formal relation between clusters shown in (320) is visible to the syntax and this relation constrains the possible positions that a feature cluster can appear. The hierarchical relation between feature clusters is mirrored in the structural hierarchy of arguments that correspond to those clusters in the syntax. This again is uncontroversial. However, where my proposal differs is that I propose that the realisation of the thematic hierarchical relation in the syntax is uniquely hierarchical. Word order is not directly determined by the feature cluster hierarchy. Any linear ordering of arguments as a consequence of the hierarchical syntactic structure is epiphenomenal. For

example, the fact that agents occur linearly before goals in a language like English is not because their thematic roles are linearly ordered, it is because of the restrictive availability of structures that can realise this hierarchical relation; in English active clauses, subjects are restricted to appear to the left of a VP and complements are restricted to a position following the verb. It is coincidental that the leftmost argument is also structurally higher than the rightmost argument. In cases where there is an option of realising the hierarchical relation in a variety of structures such as the structures of the VP in Janke and Neeleman (2012) then either structure may be utilised to express this relation. What determines which syntactic structure is used depends on factors irrelevant to thematic structure. What is important is that the selection of a syntactic 'option' must occur at the earliest stages of the syntactic encoding of a spray/load or dative event. This is the more economical option. A significant strain would be placed on a system that consistently allowed a reselection of a syntactic option after the event participants were mapped to the syntax⁶². This means that whatever triggers linear preferences must be encoded at this early stage. This leads on to an important outstanding aspect: the difference between an order of Merge and the linear order of arguments in the spray/load and dative alternations. It is to this issue that we now turn.

6.4 Distinguishing hierarchical from linear assembly: Merge versus online production

One of the central operations in generative theories is Merge – the combining (or merging) of two syntactic objects to form a new syntactic unit (e.g. Chomsky, 1995; 1999). It is generally assumed that merge takes place serially to construct more and more complex units (e.g. words combining to form phrases which combine to form clauses). Such a process determines the structural assembly of syntactic objects. This fits with the pervasive assumption that arguments are inserted into thematic positions before any syntactic operations apply. The syntactic structure begins as a direct representation of thematic structure (e.g. Larson, 1988; a.o.). However, the question is how this can be reconciled with real-time processes of production. It is widely accepted that in the production of a sentence, the grammatical constraints of the language are adhered to. One explanation is that the order of merge gradually constructs an argument structure as a real time process that proceeds up from the most deeply embedded arguments (bottom to top). Only when merge operations have been completed and all of the elements are assembled can their linear order be sorted and then the sentence produced. However, such a process would place a significant burden on Working Memory (WM) capacity especially in sentences that contain a large number of elements. This is because the

⁶² Abstracting away from strategies of goal-directed information structuring.

most deeply embedded elements tend to appear further to the right of a sentence. This is evident in the structures for the dative alternation proposed in Larson (1988) and illustrated in (321).

(321)

a. the dative construction

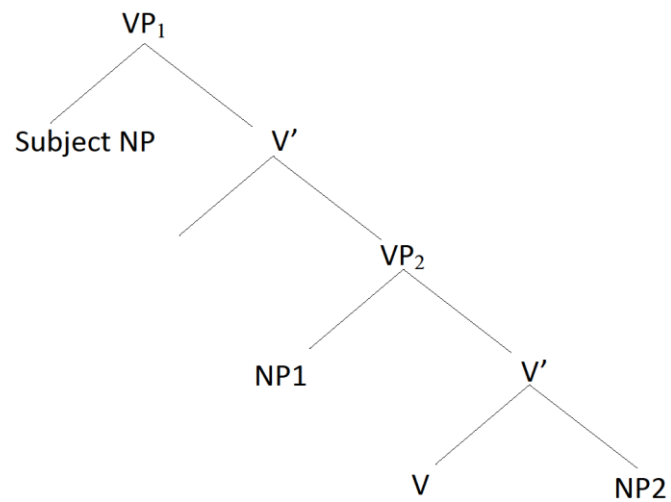

b. the double-object construction

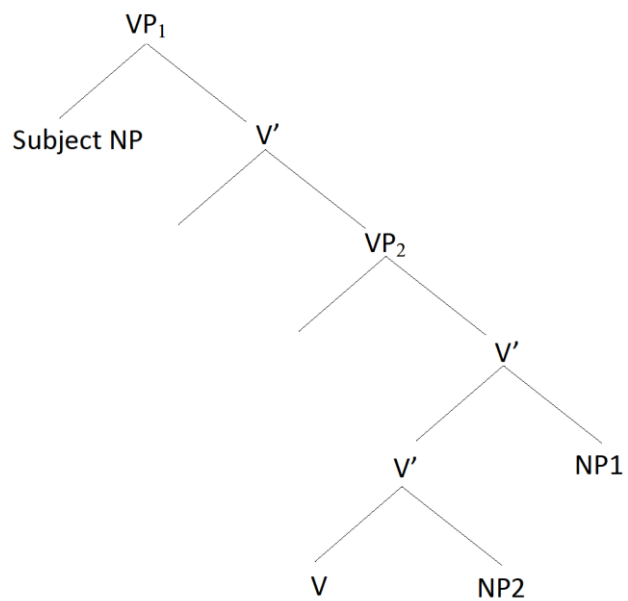

The implication of treating linear assembly and order of merger as a single process is that elements that appear at the end of the sentence must be held in storage by WM until they can be produced. This would be the case irrespective of the attention allocation of the argument triggered by its referent. This is certainly not the most efficient processing option available; specifically in a context where the material further to the right is linked to a high attention load. An alternative approach is that a syntactic frame develops incrementally as a series of possible ‘treelet’ structures, whose inclusion is triggered by properties of the items that enter the syntax⁶³. This idea has been developed for sentence parsing (cf. Fodor, 1998a, b; Sakas, 2000; Sakas and Fodor, 2001)⁶⁴. This account has not been developed for production. However, we can capture the formality of the hierarchical relations of thematic structure and include a process that incrementally assembles arguments based on a similar idea which I now propose. I claim that a structure does exist as a specified argument structure frame which is determined by the formal principles of the grammar. This can take the form of an argument structure such as a transitive active structure, or alternatively it can take the form of a smaller unit such as the VP of a *with*-variant construction. Within the frame all the constraints of the grammar are met but the slots for lexical items are empty. This is different to the Construction Grammar approach which views a construction as a holistic whole and does not make reference to grammatical rules. In this way, the hierarchical structure of thematic relations is already specified. The order that lexical items are linearly assembled is then separated from the formal process of establishing hierarchical relations. The latter is embedded in the syntax, and the former is a procedural realisation of a specific frame which denotes an event in context. Recall that structures are in competition if they can each realise the same structural relation such as the ascending and descending VPs of Janke and Neeleman (2012). The realisation of either structure is determined primarily by a principle of economy but it may also be determined outside of the syntax by factors that are relevant to the conceptualisation of the event. In either structure the order of merge is preserved – the NP1 merges first with the verb, and then NP2 merges with the resulting *V'* to form the VP. The only difference is that in a descending structure there is movement of the verb to the left of NP2 because the NP2 is reliant on it to license its case. In either case the linear order of arguments does not impact on the hierarchical structure of arguments. The grammatical encoding of an event concept is a process that occurs early in the formation of a sentence (e.g. Levelt, 1989). This means that in cases where there is competition, the particular frame that is selected must also be determined at this early stage.

⁶³ A similar proposal has been put forward in Marcus (2013).

⁶⁴ This has been an effective proposal to account for local ambiguities and garden-path effects in comprehension as in (i).

(i) Time flies like an arrow; fruit flies like a banana.

This is because there is only a limited ability to look-ahead based upon the input so misparsing is a frequent occurrence.

So, for the structure of the spray/load and dative alternation we have the encoding of the formal thematic structure in the syntax which gives us a consistent hierarchical relation between clusters. We know that economy is a driving factor so that the default structure is ascending, but we have no motivation for selecting a structure that over-rides economy - the descending structure for the *with*-variant construction and double-object construction. In order to account for this we must look to the contextual features of the event that are relevant at the time of encoding. When there is a potential ambiguity then contextual factors can over-ride the economy condition. This takes us to the features of the context discussed in (2.18.3) and chapter 5. I refer to a feature being relevant in the sense that it affects the serial order of attention focus. It is relevant if the object that it is attached to is to be referenced in the sentence. The feature is not semantic; its presence does not change the kind of event that is being described. The egocentric perception of distance is one such feature. This feature of the visual context is a property attached to objects. An object can exist in the visual field on a depth plane that is distinct from the depth plane of some other object. The results of the experiment determined that when two objects exist in the visual field, the object that is nearer captures attentional focus before the more distant object. We cannot say that this means something in the semantic sense only that it makes us process the event following a certain pattern; the serial capture of our attention causes us to view an event from a particular perspective (Tomlin, 1997) and not perceive the event as different from another event in which the distance of objects is switched. This is a stimulus-driven effect in which attention allocation is the response. It does not reflect a goal-driven strategy of actively controlling the looking from object to object in a scene. The allocation of attention has impact on the capacity of information processing of WM. WM is responsible for the processing of incoming material and the preparation of that information for further processing. When reporting a visual scene, WM must not only decode the visual stimuli that are available to perception, it must also prepare that information for a verbal report. It was argued that the most efficient way of preventing an overload of capacity is to trigger the generation of syntactic structures that allow for the early production of material that is using up the most capacity – the object that is the current focus of attention. When the language has a choice available as to the position of the referring expressions of the referents in the scene then the most efficient option is to select the structure that allows the early production of those expressions. The ascending and descending structures of Janke and Neeleman (2012) are two such structures. In a spray/load or dative event, when an item of the visual scene which corresponds to one of the object NPs captures attention before an item that corresponds to the other NP, then the selection process is informed by this relation between referents. This was shown to occur when the preference for a *with*-variant construction and a double-object construction was significantly increased when the referent of the NP2 was in the foreground

and the referent of the NP1 was in the background. We established a pattern between the linear position of the NP2 and the primacy of its referent in the serial allocation of attention compared to the referent of NP1. At the point that conceptual information is encoded, both the thematic information associated with participants in the event and the properties of the participants that interact with attention are input for the syntax. The former triggers the hierarchical arrangement of participants and the latter their linear order within the constraints of possible structures in the language. In a spray/load event the thematic input to the structure of the VP is a [-m] and [-c] cluster. In the feature cluster hierarchy the [-m] occurs lower than [-c]. This is realised structurally by the [-c] cluster appearing higher in the syntactic structure than [-m]. In a dative event the thematic input to the structure of the VP is a [-c -m] and [-c] cluster. In the feature cluster hierarchy the [-m-c] cluster occurs lower than [-c]. This is realised structurally by the [-c] cluster appearing higher in the syntactic structure than [-c -m]. In describing the event, WM is affected by the attentional values of the referents associated with these clusters. The requirement to maintain processing efficiency triggers the use of a structure that allows the expression that corresponds to the item in attentional focus to be produced first. When this is the NP2, then a descending structure is generated – a *with*-variant construction or a double-object construction. The economy condition in the syntax masks the effect of the referent of NP1 being in attentional focus before the referent of NP2. This gives us a way to account for the varying word orders in both the dative alternation and the spray/load alternation. I now move to a discussion of potential areas of future research. I begin with the elephant in the room – the presence or absence of prepositions in the *with*-variant and double-object constructions.

6.5. Areas for future research

6.5.1. Accounting for the variable presence of *with* in the *with*-variant and double-object constructions

The thesis has argued for a parallelism between the structures in the dative and spray/load alternations. What has been shown is that, hierarchically, the structure of the dative and locative variant constructions is the same, and the structure of the double-object and *with*-variant constructions is the same. In the locative variant and dative constructions the NP2 arguments are introduced by a preposition (to/into etc.) whereas the NP1 is not. In the double-object and *with*-variant constructions the NP2 argument is not introduced by a preposition. However in the *with*-variant construction the NP1 argument is introduced by the preposition *with*, whereas this is not mirrored in the double-object construction. Even though the presence of *with* does not affect the

analysis of their hierarchical structure, an interesting line of enquiry is whether we can account for this apparent dissimilarity, and whether this dissimilarity can address the differences in syntactic behaviour presented in 3.5. The motivation for this is that some dative alternating verbs listed in Levin (1993) can appear with the preposition *with* introducing the NP1 argument, as I demonstrate in (322). The verbs in (b') and (c') are also categorised as belonging to the so-called fulfilling alternation (Levin, 1993: 65). Levin points out that this alternation shows some superficial similarity to both the dative and spray/load alternation.

(322)

- a. Sam fed the machine the data.
- a'. Sam fed the machine with the data.
- b. Shipman was convicted of administering patients poison.
- b'. Shipman was convicted of administering patients with poison.
- c. The warden issued John a ticket.
- c'. The warden issued John with a ticket.
- d. Sam left Billy the washing-up.
- d'. Sam left Billy with the washing-up.
- e. The bank may reimburse you the interest you lost.
- e'. The bank may reimburse you with the interest you lost.

Interestingly the presence of a phonologically and semantically null preposition introducing the NP1 has been proposed by Emonds (1985), Hale and Keyser (1993), and Pesetsky (1995)⁶⁵ among others. Pesetsky (1995) presents an analysis in which the NP1 is headed by a null preposition which he terms *G*. He claims that there are at least two forms of *G*, one of which is *G_{with}*. Pesetsky (1995) proposes that the null preposition *G_{with}* heads a small PP clause headed by the null preposition in which the NP2

⁶⁵ A similar proposal is also given in Harley (1995; 2002)

is its specifier and the NP1 is its complement. The small clause is the complement of ditransitive verbs and G_{with} is the null preposition present in verbs of caused motion and verbs of giving such as in (323).

- (323) a. Sam gave Peter G_{with} the pencil.
 b. Sam threw John G_{with} the ball.

The small clause is also the structure Pesetsky proposes for the *with*-variant construction, except that the preposition is overt. This is illustrated in (324).

(324)

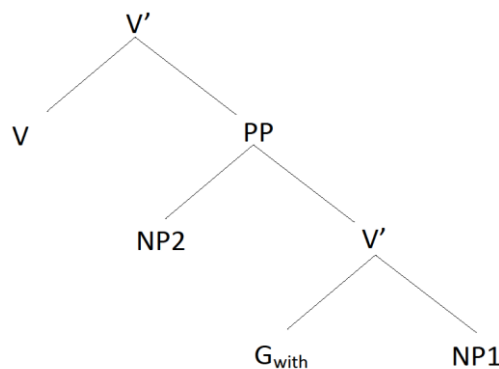

In this analysis, G is a null affixal preposition. It is proposed that the null preposition subcategorises for the overt preposition *with*⁶⁶. In the *with*-variant construction the overt preposition is realised, whereas in the double-object construction it is not. This means that the NP1 in the double-object construction is actually a prepositional phrase with the null P as its head, which suggests a similarity with the *with*-variant construction as the NP1 is now classed as a PP. Our analysis does not rest on whether the NP1 is an NP or a PP, as it is still the first argument to merge with the verb. Because the

⁶⁶ Pesetsky also claims that there is a variant of the null preposition that also subcategorises for *of*. This is not of concern here and so the reader is pointed to arguments in Pesetsky (1995: Ch5).

preposition is affixal in Pesetsky (1995), it cannot remain in the position for overt prepositions and is forced to prefix onto the verb⁶⁷ as illustrated in (325).

(325)

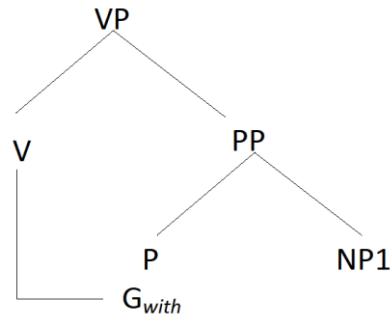

His analysis of the double-object and the *with*-variant constructions puts the NPs in the correct structural relationship to account for my data (the NP2 is structurally higher than NP1); however, he provides a unified structural analysis of the small clause for all the constructions in the dative and spray/load alternations. This causes problems for distinguishing scope interpretations. A higher NP tends to have scope over the lower NP. Pesetsky accounts for this, as was described in (2.12) by proposing that a dative or spray/load variant has access to both a descending and an ascending structure at the same time. This proposal is difficult to falsify and, as pointed out in Janke and Neeleman (2012: 184) “creates a problem of demarcation, and hence arbitrariness.”

If the idea of a null preposition is incorporated into our descending structure, then we do not cause problems for distinguishing scope interpretations; the hierarchical relation between the two NPs is maintained as illustrated in (326). The motivation for this is that scope interpretation is unaffected by the presence of the overt preposition in the *with*-variant construction, and so there seems to be no reason why a null preposition should be different.

⁶⁷ This is the raising of the null preposition by movement in Pesetsky. However we do not subscribe to a movement analysis at this level.

(326)

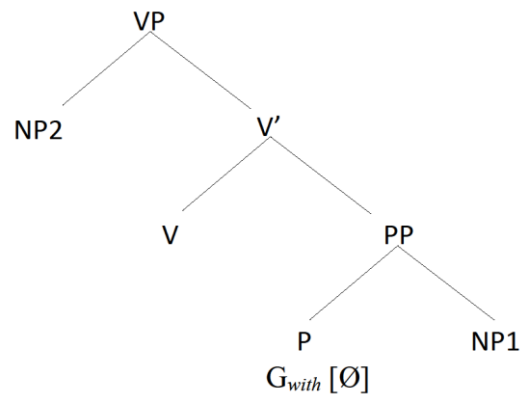

As I showed in (325) G_{with} moves to affix on to the verb leaving either a null preposition or an overt *with*. However, we may rather analyse the null preposition as a trace of the affixal G_{with} . In its position attached to the verb, G_{with} is still within the c-command domain of the trace, as I demonstrate in (327).

(327)

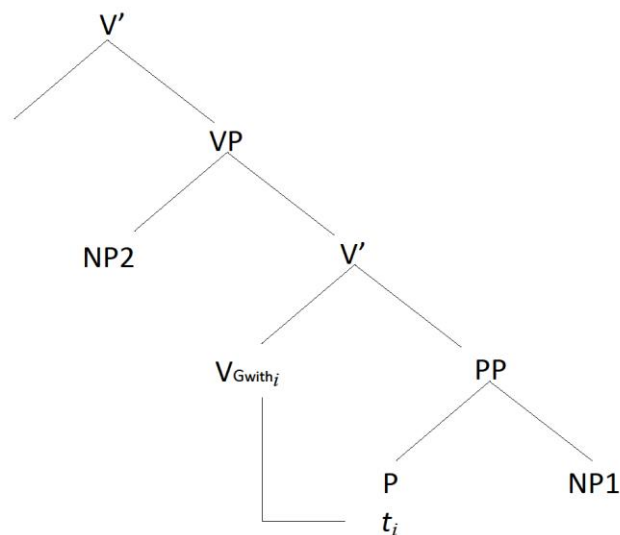

We may propose that the movement of G_{with} to the verb occurs before the verb moves to license the case feature of NP2 in the double-object construction then we avoid proposing additional movement operations and compromising economy. Once G_{with} is incorporated the verb can then move to its

position left-adjacent to NP2 as shown in (335). Notice that even in its new position the verb plus G_{with} element is still in a position to c-command the trace in P. In (328), I revert back to labelling the PP as NP1 as has been done for the *with*-variant construction throughout this thesis.

(328)

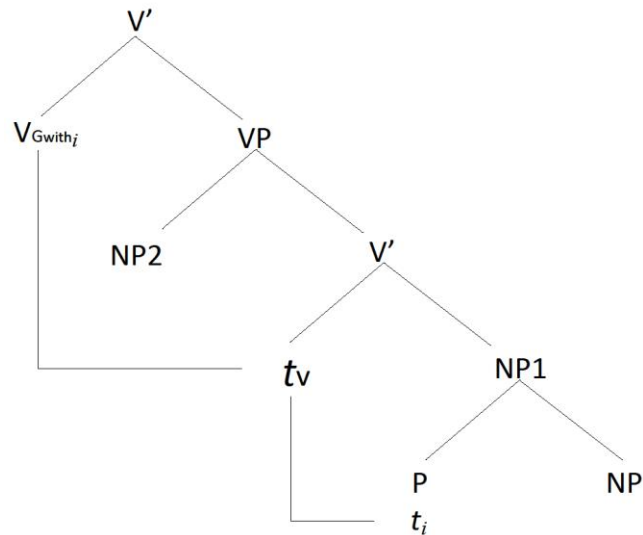

This same structure can be applied to the *with*-variant construction; the only difference is that the preposition is overt and leaves no trace, as illustrated in (329).

(329)

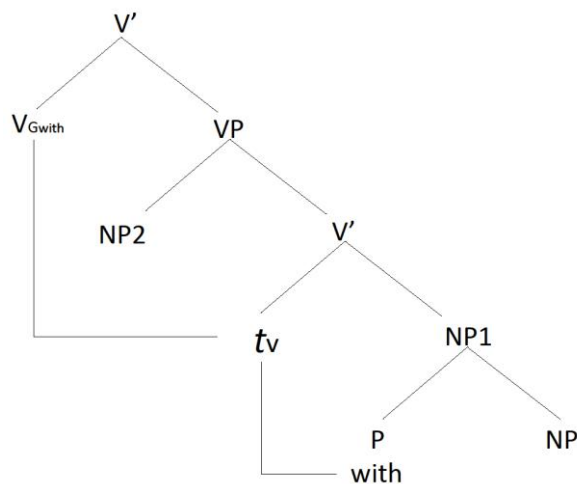

Pesetsky argues that his analysis accounts for why the double-object and *with*-variant constructions cannot form deverbal nominals, as shown in (3.4.3). The affixation of the null-preposition to the verb when it is in the lower V blocks the subsequent affixation of a nominalising morpheme to the verb. It is well known that only constituents can be moved, and this assumption forms part of the syntactician's toolkit for determining the constituency of a string of words. As we saw in the *with*-variant, the *with*-PP is not restricted in A-bar movement which indicates that it is a constituent. On the other hand, the NP1 in the double-object construction is highly restricted and subject to speaker variability. On the null hypothesis that the NP1 in the double-object construction is also a constituent, what is now a possibility is that the restriction in A-bar movement of NP1 is due to the trace-antecedent relation. A trace it must be properly bound to an antecedent. A trace and its antecedent can be viewed as a subcase of the relation between an antecedent and its bound anaphor (e.g. Dresher and Hornstein, 1979). An antecedent must c-command a variable if it is to be bound (e.g. Epstein, 1991). This then is another example in which the General Rule of Anaphoric Dependency (GPAD) from (2.13) applies. GPAD implies that when a dependent category is not contained in a subordinate clause to the antecedent then it must at least follow the antecedent to establish a coreference between them. In we can analyse the P as a trace, then the movement of NP1 would put the trace of P in a position where it no longer follows its antecedent, nor is it contained in a subordinate clause. In *wh*-movement, tough movement, and relativisation the NP1 of the double-object construction contains the dependent category – the trace of P. This means that dependent category does not follow its antecedent nor is it in a subordinate clause and so coreference cannot be established and the resulting construction is ill-formed. I illustrate this with *wh*-movement in (330). In the example the structure between V' and C' is not specified but indicated by the dotted line.

(330)

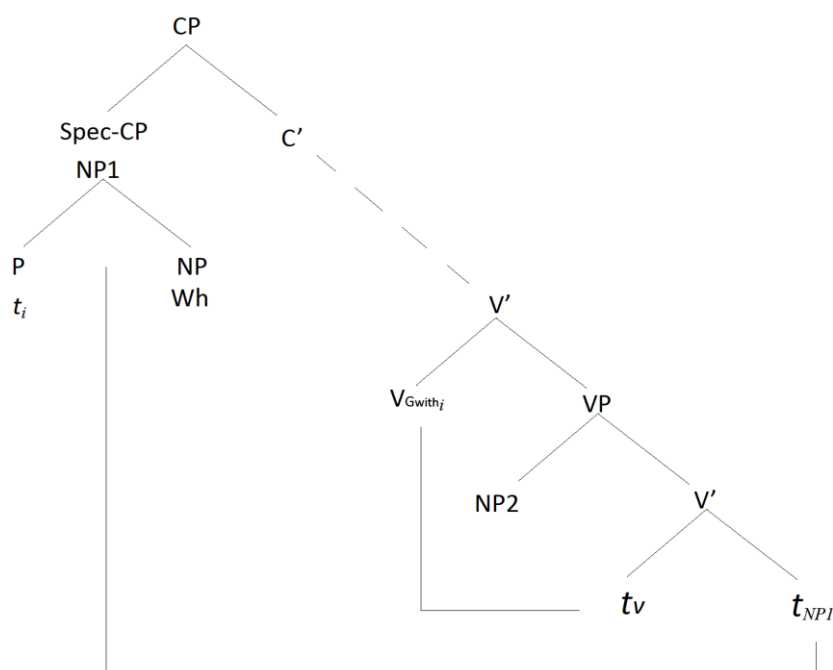

Conversely in the *with*-variant construction, the *with*-PP would be free to move as it does not have to establish a coreference between the trace of P and its antecedent. This idea if properly developed would strengthen the claim that the structures of the dative alternation are identical to the structures in the spray/load alternation. This is a neat theory internal idea but the challenge is to show an independent motivation for G_{with} . Moreover, the challenge is to align the function of G_{with} with the function of the overt preposition *with*. There are two ways in which they may align: either G_{with} is semantic with a similar meaning to overt *with*, or G_{with} is semantically empty in which case it must exhibit the same functional behaviour as overt *with*. Hale and Keyser (1996) argue for a similar small clause structure to Pesetsky (1995), but they argue that the null preposition has a semantic function. They identify the P head as a preposition of central coincidence. The preposition designates the spatial position where the two referents interact to “the extent that it is physically and practically possible, given the nature of the figure and place and the specific stance or movement of the figure, the centre of the figure coincides with the centre of the place.” Hale (1986: 239). According to Hale and Keyser (1996; 2005), central coincidence is encoded in many overt prepositions including *with* (e.g. *on, at, by, in, along, over, past, through*). These prepositions are distinguished from the prepositions of terminal coincidence (e.g. *to, into, up to, onto, from*) which encode a coincidence between one edge or *terminus* of a path and the place. Here we may have an argument for a semantic relation between

the *with* and G_{with} , we would have to accept distinguishable meaning differences between the constructions in an alternation even though the onus is placed on the preposition for the different interpretations. An alternative is Svenonius (2007) who proposes that overt *with* should be viewed as functional rather than lexical due to the wide range of interpretations introduced by *with*. *With* can (non-exhaustively) express *accompaniment* (331a), *possession* (331b), *instrument* (331c), and *manner* (331d). What these examples show is that the same *with* phrase can have various interpretations which Svenonius (2007) claims is because *with* does not assign a thematic role to its complement. The interpretation of the complement of *with* is determined by other aspects of the structure (i.e. the verb).

- (331) a. I ate a steak with a glass of wine.
b. I ate a steak with a peppercorn crust .
c. I ate a steak with a fork.
d. I ate a steak with vociferousness.

Here we may have an overt *with* counterpart to G_{with} that could be semantically vacuous. However, the challenge here then is to provide a functional analysis of *with* and align this with a functional analysis of G_{with} . As we can see, this is an area that requires much development.

6.5.2. Unifying Double Complement Alternations

The research reported in this thesis and the model supported by the experimental data provides an opportunity to unify the syntactic analysis of all double complement alternating verbs. There is a tradition to subcategorise double complement verbs by way of their semantics (e.g. Pinker, 1989; Gropen et al., 1991; Levin, 1993; Goldberg, 1995; Harley, 1996; 2002; Iwata, 2008; a.o.), such as the so-called *benefactive* alternation in (332), the *clear* alternation in (333) and the *fulfilling* alternation in (334) (cf. Levin, 1993 and references therein).

- (332) a. Bill arranged a party for Sam.
b. Bill arranged Sam a party.
- (333) a. Henry cleared the dishes from the table.
b. Henry cleared the table of dishes.
- (334) a. The judge presented a prize to the winner.
b. The judge presented the winner with a prize.

The unification of the structures of the spray/load and dative alternation might be a first step in providing a unified analysis for all alternating double-complement structures in English. No analysis that I am aware of has attempted to either provide a comprehensive structural analysis of these constructions, or has claimed that they can be unified with other double-complement structures. Moreover, I find no reference to the effect of context on the word order preferences for these constructions. It would be interesting to see if these constructions were subject to the same effects as the dative and spray/load alternations. If the preferences for the constructions in (333) to (334) were subject to the same effects of context then this would give significant strength to the claim that attention has an influence on the word order of arguments in general. I leave this idea open for future experiments.

6.5.3. Aligning grammatical theory and language processing.

The evidence and arguments presented in this thesis are particularly important for the discussion about whether one can align grammatical theories and language processing models. This was recently discussed in Lewis and Phillips (2015). The question arises around whether two separate cognitive systems are being described or whether the same cognitive system is described from different viewpoints. I would argue that the evidence in this thesis leans toward the one system view that sees the grammar as “an abstract description of the representations that the cognitive system builds.”

(Lewis and Phillips, 2015: 30). If further evidence can be collected that shows that the effect of context can influence word order possibilities then the distinction between online and offline accounts of language structure begins to disappear. The first stage would be to see whether other double-complement structures are subject to the same contextual effects as the spray/load and dative alternations discussed here. I see the challenge of bringing together grammatical theory and online processing a worthwhile endeavour. To express this, I indulge myself with an analogy for this final point: the idea that a language which expresses alternative sentences with the same meaning will ultimately boil down to the operation of one master algorithm excluding a context ignores the myriad of colour shades perceived by the painter.

I now proceed for some final remarks.

6.6. Final remarks

In this thesis I have presented an ambitious analysis of two examples of English double-complement constructions. Two rather different questions were addressed. The first was whether the syntactic representations of the spray-load alternations could be conflated with those of the dative alternation. The second was what might motivate a speaker to opt for one of these variants over the other in the first place. I have considered several theoretical models, which I have attempted to integrate in order to give a comprehensive analysis of the constructions in question. I have attempted to capture the interplay between perceptual and linguistic processes during sentence construction. In this analysis I have proposed that the Theta System of Reinhart (2000; 2002) provides the basis for a formal hierarchical input into the syntax. This model is novel in that it does not stipulate thematic labels; these are left to inferential processes based on context. This is advantageous as it provides the basis for a representational approach to the syntax. Discrepancies found between previous proposals of Thematic Hierarchies are therefore avoided. In the approach of Reinhart (2000; 2002) we did not have to postulate a separate position in the thematic hierarchy for *goals*, *locatives*, *recipients*, or *possessors*. All are argued to be inferences emanating from the same feature cluster [-c]. This gave the first indication that the meaning of the constructions in the dative alternation is the same as both constructions contain the same thematic representation, which suggests that they are not describing different events. It was indicated that the underspecification of the feature clusters for spray/load sentences suggest that these constructions are subject to a wider range of interpretations based on the possible participant role inferences associated with the clusters. This seems to hold true in the literature although no such claim is made explicit. Having established the structure of the theta cluster hierarchy, I addressed the syntactic structure of the spray/load alternation. I gave an account of its

structures based on the model of double-complement VPs in Janke and Neeleman (2012). This model is important because an approach that unifies the two constructions would not integrate with the thematic hierarchy that I argue for. Each of the structures in Janke and Neeleman were argued to be identical in respect to the hierarchical relation between NP1 and NP2. A separate question was why a speaker might choose one of these constructions over the other. This was captured by appealing to cognitive processes, specifically the allocation of processing resources (attention) and the effect it has on the maintenance of a highly restricted capacity for information processing. It was argued that this triggered the early production of referring expressions that corresponded to referents that had a high degree of information load. In support of this argument, I showed that construction preference could be captured by manipulating the attention-capturing properties of referents. I did this with an untested feature of the visual environment – the egocentric perception of distance. Egocentric perception of distance was shown to significantly affect participant preferences for one of the variants, which was an important result as it demonstrated that non-semantic information can influence the preference for a particular instantiation in the *spray/load* and dative alternatives. I also provided a speculative idea as to why there is a difference between the appearance of the preposition *with* for the NP1 in the *with*-variant construction and the double-object construction. It was suggested that a null affixal preposition and a *trace* analysis for the double-object construction could unify the structures of the NP1 phrase. This may also account for the difference in licensing A-bar movement between the two constructions. However, only an outline was provided and the idea warrants future research. If it is on the right track, it is further support for the structures being analysed in parallel. In a nutshell, the conclusions of this thesis are:

1. The locative variant construction in the *spray/load* alternation and the dative construction in the dative alternation have the same structure. This is also so of the *with*-variant construction and the double-object construction. .
2. The thematic structure of the variants in each of the alternations is identical.
3. Thematic structure only affects Merge.
4. Stimulus-driven attention can affect construction choice.
5. Stimulus-driven attention on referents that correspond to arguments in the *spray/load* and dative alternations is a contributory factor in determining preferences for one of these variants over the other.

6. The egocentric perception of distance is a variable of the visual context that can affect preferences in both the spray/load and dative alternation due to its interaction with attention allocation.

These claims are heavily dependent on the integration of the approaches used in this thesis. I am aware that the proposal forms a house of cards argument; the falsification of one of the approaches would bring the whole proposal tumbling down. However, a single approach cannot account for the data, and in the spirit of the EU framework for Research and Innovation (Horizon 2020), one can only advance research and innovate by pushing the boundaries of what is considered possible.

BIBLIOGRAPHY

Abels, K. and A. Neeleman. (2009). Universal 20 Without the LCA. In Brucart, J., Gavarro, A., and Sola. J. (Eds.). *Merging Features: Computation, Interpretation and Acquisition*. Oxford: Oxford University Press. pp. 60–79.

Abels, K. and Neeleman, A., (2012). Linear Asymmetries and the LCA. *Syntax*, 15(1): 25-74.

Aissen, J. (2003). Differential Object Marking: Iconicity vs. Economy. *Natural Language and Linguistic Theory*, 21: 435–483.

Alexiadou, A. and Schäfer F. (2006). Instrument Subjects are Agents or Causers. In Baumer, D., Montero, D., and Scanlon M. (Eds). *Proceedings of the 25th West Coast Conference on Formal Linguistics*. Somerville, MA: Cascadilla Proceedings Project. pp. 40-48.

Altmann, L., Saleem, A., Kendall, D., Heilman, K., and L. Rothi. (2006). Orthographic Directionality and Thematic Role Illustration in English and Arabic. *Brain and Language*, 97(3): 306–316.

Anagnostopoulou, E. (2003). *The Syntax of Ditransitives: Evidence from Clitics*. Berlin: Mouton de Gruyter.

Anderson, S. (1971). On the Role of Deep Structure in Semantic Interpretation. *Foundations of Language*, 6: 197-219.

Anttila, A. (2008). Phonological Constraints on Constituent Ordering. In Chang, C. and Haynie, H. (Eds.). *Proceedings of the 26th West Coast Conference on Formal Linguistics (WCCFL 26)*, Cascadilla Proceedings Project, Somerville, Massachusetts. pp. 51-59.

Aoun, J. and Li, Y. (1989). Scope and Constituency. *Linguistic Inquiry*, 20(2): 141-172.

Ariel, M. (1985b). The Discourse Functions of Given Information. *Theoretical Linguistics*, 12: 99-113.

Ariel, M. (1988). Referring and Accessibility. *Journal of Linguistics*, 24: 65-87.

Arnold, J., Wasow, T., Losongco, A., and R. Ginstrom. (2000). Heaviness vs. Newness: the Effects of Structural Complexity and Discourse Status on Constituent Ordering. *Language*, 76: 28–55.

Baddeley, A. (1986). *Working Memory*. Oxford: Oxford University Press.

- Baddeley, A. (1992). Working Memory. *Science*, 255: 556-559.
- Baddeley, A. (1995). Working Memory. In Gazzaniga, M. (Ed.). *The Cognitive Neurosciences*. Cambridge, MA: MIT Press. pp. 755-764.
- Baddeley, A. (1996). The Concept of Working Memory. In Gathercole, S. (Ed.). *Models of Short-Term Memory*. Hove: Lawrence Erlbaum Associates - Taylor and Francis. pp. 1-28.
- Baddeley, A. (2010). Working Memory. *Current Biology*, 20(4): 136-140.
- Baddeley, A. and Hitch, G. (1974). Working memory. In Bower, G. (Ed.), *Recent Advances in Learning and Motivation*, Volume 8. New York: Academic Press. pp. 47–90.
- Baker, M. (1985). *Incorporation: A Theory of Grammatical Function Changing*. Ph.D Dissertation, MIT.
- Baker, M. (1988). *Incorporation: A Theory of Grammatical Function Changing*. Chicago: University of Chicago Press.
- Baker, M. (1996). On the Structural Position of Themes and Goals. In Rooryck J. and Zaring, L. (Eds.) *Phrase Structure and the Lexicon*. Dordrecht: Kluwer. pp. 7-34.
- Baker, M.C., (1996). Thematic Roles and Syntactic Structure. In Haegeman, L. (Ed.). *Elements of Grammar: Handbook in Generative Syntax*. Netherlands: Springer, pp. 73-137.
- Baker, M. (1997). Thematic Roles and Syntactic Structure. In Haegeman (Ed.). *Elements of Grammar: Handbook of Generative Syntax*. Dordrecht: Kluwer Academic. pp. 73-138.
- Ballantyne, H. (2004). Givenness as a Ranking Criterion in Centering Theory: Evidence from Yapese. *Oceanic Linguistics*, 43(1): 49-72.
- Baltin, Mark. (1978). *Toward a Theory of Movement Rules*. Ph.D Dissertation, MIT.
- Baltin, Mark. (1982). A Landing Site Theory of Movement Rules. *Linguistic Inquiry*, 13: 1–38.
- Barss, A. and Lasnik, H., (1986). A Note on Anaphora and Double Objects. *Linguistic inquiry*, 17(2): 347-354.
- Beavers, J. (2006). Semantic Underspecificity in English Argument/Oblique Alternations. *WECOL 2004*, 26.
- Beck, S. and Johnson, K. (2004). Double Objects Again. *Linguistic Inquiry*, 35(1): 97-124.

- Belletti, A. and Rizzi, L. (1988). The Syntax of *Ne*: Some Theoretical Implications. *Linguistic Review*, 1: 117-154.
- Bencini, G. and Goldberg, A. (2000). The Contribution of Argument Structure Constructions to Sentence Meaning. *Journal of Memory and Language*, 43(4): 640-651.
- Birner, B. (1998). Recency Effects in English Inversion. In Walker, M., Joshi, A., and Prince, E. (Eds.). *Centering Theory in Discourse*. Oxford: Clarendon Press. pp. 309-323.
- Bobaljik, J. (1995). *Morphosyntax: The Syntax of Verbal Inflection*. Ph.D Dissertation. MIT.
- Bobaljik, J. (2003). Floating quantifiers: Handle with Care. In Cheng, L. and Sybesma, R. (Eds.). *The Second Glot International State-of-the-Article Book*. Berlin: Mouton de Gruyter. pp. 107-148.
- Bock, J., Loebell, H., and Morey, R. (1992). From Conceptual Roles to Structural Relations: Bridging the Syntactic Cleft. *Psychological Review*, 99: 150–171.
- Bock, J. and Warren, R. (1985). Conceptual Accessibility and Syntactic Structure in Sentence Formulation. *Cognition*, 21: 47-67.
- Borkin, A. (1974). *Problems with Form and Function*. Ph.D Dissertation, University of Michigan.
- Bošković, Ž. (1994) D-structure, Theta-criterion, and Movement into Theta-positions. *Linguistic Analysis*, 24: 247-286.
- Bošković, Ž. (2004). Be Careful Where You Float Your Quantifiers. *Natural Language and Linguistic Theory*, 22: 681-742.
- Branigan, H., Pickering, M., and Tanaka, M. (2008). Contributions of Animacy to Grammatical Function Assignment and Word Order during Production. *Lingua*, 118: 172-189.
- Bresnan, J. (1982a). The Passive in Lexical Theory. In Bresnan, J. (Ed.). *The Mental Representation of Grammatical Relations*. Cambs, Mass.: MIT Press. pp. 3-86.
- Bresnan, J. and Kanerva, J. (1989). Locative Inversion in Chichewa: A Case Study of Factorization in Grammar. *Linguistic Inquiry*, 20: 1-50.
- Bresnan, J. and Nikitina, T. (2003). *The Gradience of the Dative Alternation*. Unpublished Ms: Stanford University.

- Bresnan, J., Cueni, A., Nikitina, T., and H. Baayen. (2007). Predicting the Dative Alternation. In Boume, G., Kraemer, I., and J. Zwarts, (Eds.). *Cognitive Foundations of Interpretation*. Amsterdam: Royal Netherlands Academy of Science. pp. 69–94.
- Bresnan, J. and Hay. J. (2008). Gradient Grammar: An Effect of Animacy on the Syntax of *Give* in New Zealand and American English. In Lamers, M., Lestrade, S., and de Swart, P. (Eds.). *Animacy, Argument Structure, and Argument Encoding: Special Issue of Lingua 118(2)*. Amsterdam: Elsevier. pp. 245–59.
- Bruening, B. (2001). QR Obeys Superiority: ACD and Frozen scope. *Linguistic Inquiry*, 32: 233–273.
- Broadwell, G. (1986). Multiple Theta-Role Assignment. In McDonough, J. and Plunkett, B. *Proceedings of NELS 17*, Volume I: 46-58.
- Bruno, N. and Cutting, J. (1988). Minimodularity and the Perception of Layout. *Journal of Experimental Psychology: General*, 117: 161-170.
- Büring, D. (2005). *Binding Theory*. Cambridge: Cambridge University Press.
- Burzio, L. (1986). *Italian Syntax*. Dordrecht: Reidel Publishing.
- Carlson, G. (1998). Thematic Roles and the Individuation of Events. In Rothstein, S. (Ed.). *Events and Grammar*. Dordrecht: Kluwer Academic. pp. 35-51.
- Carrier-Duncan J. (1985). Linking of Thematic Roles in Derivational Word Formation. *Linguistic Inquiry*, 16: 1-34.
- Case, R., Kurland, M., and Goldberg, J. (1982). Operational Efficiency and the Growth of Short-Term Memory Span. *Journal of Experimental Child Psychology*, 33: 386-404.
- Castiello, U. and Umiltà, C. (1990). Size of the Attentional Focus and Efficiency of Processing. *Acta Psychologica* 73(3): 195-209.
- Chafe, W. (1976). Givenness, Contrastiveness, Definiteness, Subjects, Topics, and Points of View. In Li, C. (Ed.). *Subject and Topic*. New York: Academic Press. pp: 25-55.
- Champion, R. and Warren, P. (2010). Ground-Plane Influences on Size Estimation in Early Visual Processing. *Vision Research*, 50: 1510-1518.
- Chomsky, N., (1973). Conditions on Transformations. In Anderson, S. and Kiparsky, P. (Eds.). *A Festschrift for Morris Halle*. New York: Holt, Rinehard and Winston. pp. 232-286.

- Chomsky, N., and Lasnik, H. (1977). Filters and Control. *Linguistic Inquiry*, 8(3): 425-504.
- Chomsky, N. (1981). *Lectures on Government and Binding*. Dordrecht: Foris.
- Chomsky, N. (1986). *Barriers. Linguistic Inquiry Monograph Thirteen*. Cambs, Mass.: MIT Press.
- Chomsky, N. (1986a). *Knowledge of Language: Its Nature, Origin, and Use*. New York: Praeger.
- Chomsky, N. (1991). Some Notes on the Economy of Derivations and Representation. In Friedin, R. (Ed.). *Principles and Parameters in Comparative Grammar*. Cambs, Mass.: MIT Press. pp. 417-454.
- Chomsky, N. (1992). *A Minimalist Program for Linguistic Theory*. MIT Occasional Papers in Linguistics, 1. Cambs.: Mass: MITWPL.
- Chomsky, N. (1995). *The Minimalist Program*. Cambs, Mass.: MIT Press.
- Chomsky, N. (1999). *Derivation by Phase*. Cambridge, Mass.: MIT Press.
- Clark, E. (1978). Locational: Existential, Locative, and Possessive Constructions. In Greenberg, J. Ferguson, C. and Moravcsik, E. (Eds.). *Universals of Human Language, 4: Syntax*. Stanford: Stanford University Press. pp. 85-126.
- Clark, E, and Clark, H. (1979). When Nouns Surface as Verbs. *Language*, 55: 767-811.
- Colston, H. and Keller, S. (1998). You'll Never Believe This: Irony and Hyperbole in Expressing Surprise. *Journal of Psycholinguistic Research*, 27(4): 499-513.
- Cowan, N., Li, D., Moffitt, A., Becker, T., Martin, E., Saults, J., and Christ, S. (2011). A Neural Region of Abstract Working Memory. *Journal of Cognitive Neuroscience*, 23(10): 2852-2863.
- Crăiniceanu, I. and Baci, I. (2007). Blocking Effects in the Double Object Construction. *Studii si Cercetari Lingvistice (SCL)*, 2: 263-270.
- Culicover P. and Jackendoff, R. (2005). *Simpler Syntax*. Oxford University Press.
- Cutting, J. and Vishton, P. (1995). Perceiving Layout: The Integration, Relative Dominance, and Contextual Use of Different Information about Depth. In Epstein, W. and Rogers, S. (Eds.). *Handbook of Perception and Cognition, Vol. 5: Perception of Space and Motion*. New York: Academic Press. pp. 69-117.
- Czepluch, H. (1982). Case Theory and the Dative Construction. *The Linguistic Review*, 2(1): 1-38.

- Dahl, Ö. and Fraurud, K. (1996). Animacy in Grammar and Discourse. In Fretheim, T. and Gundel, J. (Eds.). *Reference and Referent Accessibility*. Amsterdam: John Benjamins. pp. 47–64.
- Damonte, F. (2004). Classifier Incorporation and the Locative Alternation. In Munaro, N., Turano, G. and Schweikert, W. (Eds.). *Proceedings of the XXX Incontro di Grammatica Generativa*. Venezia: Cafoscarina. pp.83-103.
- Daneman, M. and Carpenter, P. (1980). Individual Differences in Working Memory and Reading. *Journal of Verbal Learning and Verbal Behaviour*, 19(4): 450-466.
- DeLancey, S. (2001). The Mirative and Evidentiality. *Journal of Pragmatics*, 33: 369–382.
- den Dikken, M. (1995). *Particles*. Oxford: Oxford University Press.
- Desimone, R. and Duncan, J. (1995). Neural Mechanisms of Selective Visual Attention. *Annual Review of Neuroscience*, 18: 193-222.
- De Vries, M. (2002). *The Syntax of Relativisation*. Utrecht: LOT.
- Dik, S. (1978). *Functional Grammar*. Amsterdam: North Holland.
- Downing, P. (2000). Interactions Between Visual Working Memory and Selective Attention. *Psychological Science*, 11(6): 467-473.
- Dowty, D. (1991). Thematic Proto-Roles and Argument Selection. *Language*, 67: 547-619.
- Dowty, D.R. (1999). *Argument Alternations, Lexical Polysemy and Thematic Roles: A Case Study*. [Online]. Available from: <http://www.ling.ohio-state.edu/~dowty/swarm-bees.hdt.norway>
- Dowty, D. (2000). The Garden Swarms with Bees and the Fallacy of Argument Alternation. In Ravin, Y. and Leacock, C. (Eds.). *Polysemy: Theoretical and Computational Approaches*. Oxford: Oxford University Press. pp. 111-128.
- Dowty, D. (2001). *The Asymmetry of Argument Alternations (and Why it Matters)*. *Groninger Arbeiten zur Germanistischen Linguistik*, 44. [Online]. Available from: <http://ling.ohiostate.edu/~dowty/papers/groningen-00.pdf>
- Dowty, D. (2003). The Dual Analysis of Adjuncts/Complements in Categorical Grammar. In Lang, E., Maienborn, C. and Fabricius-Hansen, C. (Eds.). *Modifying Adjuncts*. Berlin: Mouton de Gruyter. pp. 33-66.

- Dresher, B. and Hornstein, N. (1979). Trace Theory and NP Movement Rules. *Linguistic Inquiry*, 10(1): 65-82.
- D'Zmura, M. (1991). Color in Visual Search. *Vision Research*, 31(6): 951-966.
- Egeth, H. and Yantis, S. (1997). Visual Attention: Control, Representation, and Time Course. *Annual Review of Psychology*, 48: 269-297.
- Emonds, J. (1985). *A Unified Theory of Syntactic Categories*. Dordrecht: Foris.
- Engle, R., Cantor, J., and Carullo, J. (1992). Individual Differences in Working Memory and Comprehension: A Test of Four Hypotheses. *Journal of Experimental Psychology: Learning, Memory, and Cognition*, 18: 972-992.
- Epstein, S. (1991). *Traces and their Antecedents*. Oxford: Oxford University Press.
- Eriksen, C. and St. James, J. (1986). Visual Attention Within and Around the Field of Focal Attention: A Zoom Lens Model. *Perception and Psychophysics*, 40(4): 225-240.
- Everaert, M., Marelj, M. and Siloni, T. (2012). The Theta System: An Introduction. In Everaert, M., Marelj, M. and Siloni, T. (Eds.). *The Theta System: Argument Structure at the Interface*. Oxford: Oxford University Press. pp. 1-19.
- Ferreira, F. (1994). Choice of Passive Voice is Affected by Verb Type and Animacy. *Journal of Memory and Language*, 33: 715-736.
- Ferreira, V. and Dell, G. (2000). Effect of Ambiguity and Lexical Availability on Syntactic and Lexical Production. *Cognitive Psychology*, 40(4): 296-340.
- Fillmore, C. (1968). The Case for Case. In Bach, E and Harms, R. (Eds.). *Universals in Linguistic Theory*. New York: Holt, Rinehart, and Winston. pp. 1-68.
- Fillmore, C. (1971). Some Problems for Case Grammar. In O'Brien, R. (Ed.). *Report of the 22nd Annual Round Table Meeting on Linguistics and Language Studies*. Washington: Georgetown University Press. pp. 35-56.
- Fillmore, C. (1977). The Case for Case Reopened. In Cole, P. (Ed.). *Syntax and Semantics 8: Grammatical Relations*. New York: Academic Press. pp. 59 - 81.

- Fillmore, C. (1989). Grammatical Construction Theory and the Familiar Dichotomies. In: Dietrich, R. and Graumann, C. (Eds.). *Language Processing in Social Context*. Amsterdam: North Holland. pp. 17-38.
- Fillmore, C. and Kay, P. (1999). Regularity and Idiomaticity in Grammatical Constructions: The Case of Let Alone. *Language*, 64: 501–538.
- Fodor, J. (1998a). Unambiguous Triggers. *Linguistic Inquiry*, 29(1): 1-36.
- Fodor, J. (1998b). Parsing to Learn. *Journal of Psycholinguistic Research*, 27: 339-374.
- Franconeri, S. and Simons, D. (2003). Moving and Looming Stimuli Capture Attention. *Perception and Psychophysics*, 65(7): 999-1010.
- Fraser, B. (1971). A Note on the Spray Paint Cases. *Linguistic Inquiry*, 2(4): 604-607.
- Frey, H., Wirz, K., Willenbockel, V., Betz, T., Schreiber, C., Toscianno, T., and P. König. (2011). Beyond Correlation: Do Color Features Influence Attention in Rainforest? *Frontiers in Human Neuroscience*, 5:36.
- Fried, M. (2011). Construction Grammar. In Alexiadou, A. and Kiss, T. (Eds.). *Handbook of Syntax, Vol. 2*. (2nd ed.). Berlin: Walter de Gruyter. pp. 974-1003.
- Fukumura, K. and van Gompel, R. (2011). The Effect of Animacy on the Choice of Referring Expression. *Language and Cognitive Process*. 26: 1472–1504.
- Fuller, S. and Carraco, M. (2006). Exogenous Attention and Color Perception: Performance and Appearance of Saturation and Hue. *Vision Research*, 46: 4032–4047.
- Gardner, P. and Mon-Williams, M. (2001). Vertical Gaze Angle: Absolute Height-in-Scene Information for the Programming of Prehension. *Experimental Brain Research*, 136(3): 379-385.
- Gibson, J. (1972). A Theory of Direct Visual Perception. In Royce, J. and Rozenboom, W. (Eds.). *The Psychology of Knowing*. New York: Gordon and Breach. pp. 215-236.
- Gerwin, J. (2014). *Ditransitives in British English Dialects*. Berlin: Walter de Gruyter.
- Givón, T. (1984). *Syntax: A Functional-Typological Introduction Volume 1*. Amsterdam: John Benjamins.

- Givón, T. (1988). The Pragmatics of Word Order: Predictability, Word Order and Attention. In Hammond, M., Moravcsik, E., and Wirth, J. (Eds.). *Studies in Syntactic Typology*. Amsterdam: John Benjamins. pp. 243-284.
- Gleitman, L., January, D., Nappa, R., and J. Trueswell. (2007). On the Give and Take Between Event Apprehension and Utterance Formulation. *Journal of Memory and Language*, 57(4): 544–569.
- Gogel, W. (1953). The Visual Perception of Size and Distance. *Vision Research*, 3: 101-120.
- Goldberg, A. (1992c). The Inherent Semantics of Argument Structure: The Case of the English Ditransitive Construction. *Cognitive Linguistics*, 3(1):37-74.
- Goldberg, A. (1995). *A Construction Grammar Approach to Argument Structure*. Chicago: University of Chicago Press.
- Goldberg, A. (1997). Relationships Between Verb and Construction. In Verspoor, M. and Sweetser, E. (Eds.). *Lexicon and Grammar*. Amsterdam: John Benjamins. pp. 383–398.
- Goldberg, A. (2000). Patient Arguments of Causative Verbs can be Omitted: the Role of Information Structure in Argument Distribution. *Language Science*, 23: 503-524.
- Goldberg, A. (2002) Surface Generalizations: an Alternative to Alternations. *Cognitive Linguistics*, 13(4): 327-356.
- Goldberg, A. (2003). Constructions: A New Theoretical Approach to Language. *Trends in Cognitive Sciences*, 7(5): 219-224.
- Goldberg, A. (2006.) *Constructions at Work*. Oxford: Oxford University Press.
- Goldberg, A. and Ackerman, F. (2001). The Pragmatics of Obligatory Adjuncts. *Language*, 77(4): 798-814.
- Green, G. (1974). *Semantics and Syntactic Regularity*. Bloomington, Indiana: Indiana University Press.
- Greenberg, J., (1963). Some Universals of Grammar with Particular Reference to the Order of Meaningful Elements. In Greenberg, J. (Ed.). *Universals of Language*. Cambs, Mass.: MIT. pp. 73–113.
- Grice, P (1975). Logic and Conversation. In Cole and Morgan (Eds.). *Syntax and Semantics volume III: Speech Acts*. NY: Academic Press. pp. 41-58.

- Grimshaw, J. (1990). *Argument Structure*. Cambs, Mass.: MIT Press.
- Grimshaw, J. (1993). *Minimal Projections, Heads, and Optimality*. Ms, Rutgers University.
- Gropen, P., Pinker, S., Hollander, M., Goldberg, R. and R. Wilson (1989). The Learnability and Acquisition of the Dative Alternation in English. *Language*, 65(2): 203-257.
- Gropen, P., Pinker, S., Hollander, M. and R. Goldberg. (1991). Affectedness and Direct Objects: The Role of Lexical Semantics in the Acquisition of Verb Argument Structure. *Cognition*, 41: 153-195.
- Grossberg, S. (1994). 3-D Vision and Figure-Ground Separation by Visual Cortex. *Perception and Psychophysics*, 55: 48-120.
- Gundel, J. (1988). Universals of Topic-Comment Structure In Hammond, M., Moravczik, E. and Wirth, J. (Eds.). *Studies in Syntactic Typology*. Amsterdam: John Benjamins. pp. 209-239.
- Gundel, J.K., Hedberg, N., and Zacharski, R. (1993). Cognitive Status and the Form of Referring Expressions in Discourse. *Language*, 69: 274–307.
- Gundel, J., Bassene, M., Gordon, B., Humnick, L., and A. Khalfaoui. (2010). Testing Predictions of the Givenness Hierarchy Framework: A Crosslinguistic Investigation. *Journal of Pragmatics*, 42(7): 1770-1785.
- Gussenhoven, C. (1999). Discreteness and Gradience in Intonational Contrasts. *Language and Speech*, 2-3: 283-305.
- Gruber, J. (1965), *Studies in Lexical Relations*. Cambridge Mass.: MIT Press.
- Hale, K. (1986). Notes on World View and Semantic Categories: Some Warlpiri Examples. In Muysken, P. and van Riemsdijk H. (Eds.). *Features and Projections*. Dordrecht: Foris. pp. 233-254.
- Hale, K. and Keyser, S. (1995). *The Limits of Argument Structure*. Ms, MIT.
- Hale, K. and Keyser, S. (1996). On the Double-Object Construction. Unpublished Ms. [Online]. Available from: <http://www.museunacional.ufrj.br/linguistica/congresso/1/txdoc.pdf>
- Hale, K. And Keyser, S. (2002). *Prolegomenon to a Theory of Argument Structure*. Cambs, Mass.: MIT Press.

- Hale, K. and Keyser, S. (2005). Aspect and the Syntax of Argument Structure. In Erteschik-Shir, N. and Rapoport, T. (Eds.), *The Syntax of Aspect: Deriving Thematic and Aspectual Interpretation*. Oxford: Oxford University Press. pp. 11-41.
- Harley, H. (1996). If You Have, You Can Give. In Agbayani, B. and Tang, S-W. (Eds.). *Proceedings of WCCFL XV*. Stanford: CSLI. pp. 193-207.
- Harley, H. (2002). Possession and the Double Object Construction. In Pica, P. and Rooryck, J. *Yearbook of Linguistic Variation: Volume 2*. Amsterdam: John Benjamins. pp. 29-68.
- Hartmann, J. (2008). Dwarf-Class Verbs, Theta-Theory, and Argument Linking. In Abner, N. and Bishop, J. (Eds.). *Proceedings of the 27th West Coast Conference on Formal Linguistics*. Somerville, MA: Cascadilla Proceedings Project. pp. 203-210.
- Haspelmath, M. (2004a). Explaining the Ditransitive Person-Role Constraint: a Usage-Based Account. *Constructions*, 2/2004: 1-72. [Online]. Available from: <http://journals.linguisticsociety.org/elanguage/constructions/article/view/3073.html>
- Heine, B. (1992). Grammaticalization Chains. *Studies in Language*, 16: 335–368.
- Henderson, J. and Ferreira, F. (2004). Scene Perception for Psycholinguistics. In Henderson, J. and Ferreira, F. (Eds.). *The Interface of Language, Vision, and Action: Eye Movements and the Visual World*. New York: Psychology Press. pp. 1-58.
- Herriman, J. and Seppänen, A. (1996). What is an Indirect Object. *English Language Studies*, 77(5): 484-500.
- Higginbotham, J. (1980). Pronouns and Bound Variables. *Linguistic Inquiry*, 11: 679–708.
- Hoeksema, J. (2000). Negative Polarity Items: Triggering Scope and C-command. In Horn, L. and Kato, Y. (Eds.). *Negation and Polarity*. Oxford: Oxford University Press. pp. 115-146.
- Hoekstra, T. (1984). *Transitivity*. Dordrecht: Foris.
- Hoffman, D. and Singh, M. (1997). Salience of Visual Parts. *Cognition*, 63: 29-78.
- Hole, D. (2015). Arguments and Adjuncts. In Kiss, T. and Alexiadou, A. (Eds.). *Syntax – Theory and Analysis: an International Handbook*. Berlin: de Gruyter. pp. 1284-1320.

- Hornstein, N. and A. Weinberg. (1981). Case Theory and Preposition Stranding. *Linguistic Inquiry*, 12: 55-91.
- Horstmann, G. (2006). The Time Course of Intended and Unintended Allocation of Attention. *Psychological Research*, 70: 13–25.
- Houser, M. (2010). *The Syntax and Semantics of Do So Anaphora*. Ph.D Dissertation, University of California, Berkeley.
- Huddleston, R. and Pullum, G. (2005). *A Student Introduction to English Grammar*. Cambridge: Cambridge University Press.
- Hull, C. (1943). *Principles of Behavior*. New York: Appleton-Century-Crofts.
- Ibbotson, P., Lieven, E. And Tomasello, M. (2013a). The Attention-Grammar Interface: Eye-Gaze Cues Structural Choice in Children and Adults. *Cognitive Linguistics*, 24(3): 457-481.
- Itti, L. and Koch, C. (2001). Computational Modelling of Visual Attention. *Nature Reviews Neuroscience*, 2(3): 194-203.
- Iwata, S. (2008). *Locative Alternation: A Lexical-Constructional Approach*. Amsterdam: John Benjamins.
- Jackendoff, R. (1972). *Semantic Interpretation in Generative Grammar*. Cambs, Mass.: MIT Press.
- Jackendoff, R. (1987). The Status of Thematic Relations in Linguistic Theory. *Linguistic Inquiry*, 18(3): 369-411.
- Jackendoff, R. (1990). *Semantic Structures*. Cambs, Mass.: MIT Press.
- Jackson, R. and Calvillo, D. (2013). Evolutionary Relevance Facilitates Visual Information Processing. *Evolutionary Psychology*, 11(5): 1011-1026.
- Jackson, R. and Calvillo, D. (2014). Animacy, Perceptual Load, and Inattentional Blindness. *Psychonomic Bulletin Review*, 21: 670-675.
- Jacobs, J. (1994) *Kontra Valenz*. Trier: Wissenschaftlicher Verlag.
- Jaeger, T. and Norcliffe, E. (2009). The Cross-linguistic Study of Sentence Production. *Language and Linguistics Compass*, 3(4), 866–887.

- Janke, J. and Neeleman, A. (2012). Ascending and Descending VPs in English. *Linguistic Inquiry*, 43: 151-190.
- Johnson, K., (1991). Object Positions. *Natural Language and Linguistic Theory*, 9: 577-636.
- Jonides, J. (1981). Voluntary vs. Automatic Control Over the Mind's Eye's Movements. In Long J. and A. Baddeley, A. (Eds.). *Attention and Performance IX*. Hillsdale, NJ: Erlbaum. pp. 187–203.
- Julesz, B. (1984). A Brief Outline of the Texton Theory of human Vision. *Trends in Neuroscience*, 7: 41-45.
- Kamp, H. and Rossdeutscher, A. (1994). Remarks on Lexical Structure and DRS Construction. *Theoretical Linguistics*, 20: 97-164.
- Kaufman, L. (1974). *Sight and Mind*. Oxford: Oxford University Press.
- Kayne, R. (1969). *The Transformational Cycle in French Syntax*. Ph.D. Dissertation, MIT.
- Kayne, R. (1975). *French Syntax: The Transformational Cycle*. Cambs, Mass.: MIT Press.
- Kayne, R. (1984). *Connectedness and Binary Branching*. Dordrecht: Foris.
- Kayne, R. (1984c). Unambiguous Paths. In Kayne, R. (Ed.). *Connectedness and Binary Branching*. Dordrecht: Foris. pp. 129-164.
- Kienker, P., Sejnowski, T., and Hinton, G. (1986). Learning Symmetry Groups with Hidden Units: Beyond the Perceptron. *Physica*, 22d: 260-275.
- Kirchner, H. and Thorpe, S. (2006). Ultra-Rapid Object Detection with Saccadic Eye Movements: Visual Processing Speed Revisited. *Vision Research*, 46: 1762–1776.
- Koenig, J., Maurer, G., and Bienvenue, B. (2003). Arguments for Adjuncts. *Cognition*, 89(2): 67-103.
- Koopman, H. (1987). *On the Absence of Case Chains in Barnbara*. Ms. UCLA.
- Krifka, M. (2001). Lexical Representations and the Nature of the Dative Alternation. DIP Colloquium University of Amsterdam, November 9, 2001. [Online]. Available from: <http://amor.cms.hu-berlin.de/~h2816i3x/Talks/DativeAmsterdam.pdf>
- Krifka, M. (2003). Semantic and Pragmatic Conditions for the Dative Alternation. *Korean Journal of English Language and Linguistics*, 4 (2004), 1-32.

- Kristjánsson, A. (2006a). Rapid Learning in Attention Shifts—A review. *Visual Cognition*, 13: 324–362.
- Kronenberger, W., Pisoni, D., Colson, B., and S. Henning. (2010). *Enhancing Language and Cognitive Processing Skills with Working Memory Training*. Alexander Graham Bell Convention. Lecture conducted from Hilton Orlando Bonnet Creek, Orlando, Florida.
- Kuno, S., and Robinson, J. (1972). Multiple Wh-Questions. *Linguistic Inquiry*, 3(4): 463-488.
- LaBerge, D. (1995). *Attentional Processing: The Brain's Art of Mindfulness*. Cambs, Mass.: Harvard University Press.
- Lakoff, G. and Ross, J. (1976). Why You Can't *do so* Into the Kitchen Sink. In McCawley, J. (Ed.). *Syntax and Semantics 7: Notes from the Linguistic Underground*. New York: Academic Press. pp. 101-111.
- Laffut, A. and Davidse, K. (2002). English Locative Constructions: An Exercise in Neo-Firthian Description and Dialogue with Other Schools. *Functions of Language*, 9(2): 169-207.
- Lakoff, G. (1993). The Contemporary Theory of Metaphor. In Ortony, A. (Ed.). *Metaphor and Thought*, 2nd ed. Cambridge: Cambridge University Press.
- Lamy, D. and Kristjánsson, Á. (2013). Is Goal-Directed Attentional Guidance Just Intertrial Priming? A Review. *Journal of Vision*, 13(3): 14. [Online]. Available from: <http://jov.arvojournals.org/article.aspx?articleid=2194097>
- Lamy, D., Leber, A., and Egeth, H. (2012). Selective Attention. In Healy A. and Proctor, R. (Eds.). *Comprehensive Handbook of Psychology, Vol.4: Experimental Psychology 4th ed*. New York: Wiley. pp. 265-294.
- Landy, M., Maloney, L. and Young, M. (1991). Psychophysical Estimation of the Human Depth Combination Rule. In Schenker, P. (Ed). *Sensor Fusion III: 3-D Perception and Recognition, Proceedings of the SPIE, 1383*. pp. 247-254.
- Langacker R. (1991). *Foundations of Cognitive Grammar, Volume 2: Descriptive Application*. Stanford: Stanford University Press.
- Larson, R. (1988). On the Double Object Construction. *Linguistic Inquiry*, 19: 335-391.
- Larson, R. (1990). Double Objects Revisited: A Reply to Jackendoff. *Linguistic Inquiry*, 21: 589-632.
- Larson, R. (2014). *On Shell Structure*. Oxford: Routledge.

- Lasnik, H. (2000). *Syntactic Structures Revisited: Contemporary Lectures on Classic Transformational Theory*. Cambs, Mass.: MIT Press.
- Lavie, N. (1995). Perceptual Load as a Necessary Condition for Selective Attention. *Journal of Experimental Psychology: Human Perception and Performance*, 21(3): 451-468.
- Lavie, N., de Fockert, J., and Viding, E. (2004). Load Theory of Selective Attention and Cognitive Control. *Journal of Experimental Psychology: General*, 133(3): 339-354.
- Lebeaux, D (1983). A Distributional Difference Between Reciprocals and Reflexives. *Linguistic Inquiry*, 14(4): 723-730.
- Levelt, W. (1989). *Speaking: From Intention to Articulation*. Cambs, Mass.: MIT Press.
- Levin, B. and Rappaport, M. (1988). Lexical Subordination. *CLS*, 24, Part 1: 275-289.
- Levin, B. and Rappaport Hovav, M. (2005). *Argument Realization: Research Surveys in Linguistics Series*. Cambridge: Cambridge University Press.
- Levin, B. (1993). *English Verb Classes and Alternations: A Preliminary Investigation*. Chicago: Chicago University Press.
- Levin, B. (2014). Semantic Roles. In Aronoff, M. (Ed). *Oxford Bibliographies in Linguistics*, New York: Oxford University Press. [Online]. Available from: <http://oxfordbibliographies.com/view/document/obo-9780199772810/obo-9780199772810-0141.xml>
- Lewis, S. and Phillips, C. (2015). Aligning Grammatical Theories and Language Processing Models. *Journal of Psycholinguistic Research*, 44(1): 27-46.
- Loomis, J. and Knapp, J. (2003). Visual Perception of Egocentric Distance in Real and Virtual Environments. *Virtual and Adaptive Environments*, 11: 21-46.
- Liu, T., Yuan, Z., Sun, J., Wang, J., Zheng, N., Tang, X., and H. Shum. (2011). Learning to Detect Salient Objects. *IEEE Transactions on Pattern Analysis and Machine Intelligence*, 33: 353–367.
- Maass, A. and Russo, A. (2003). Directional Bias in the Mental Representation of Spatial Events: Nature or Culture? *Psychological Science*, 14(4): 296-301.
- MacWhinney, B. (1977). Starting Points. *Language*, 53(1): 152-168.

- Majerus, S., Attout, L., D'Argembeau, A., Degueldre, C., Fias, W., Maquet, P., Martinez Perez, T., Stawarczyk, D., Salmon, E., Van der Linden, M., Phillips, C., and E. Balteau. (2012). Attention Supports Verbal Short-Term Memory via Competition between Dorsal and Ventral Attention Networks. *Cerebral Cortex*, 22: 1086-1097.
- Maling, J. (1976). Notes on Quantifier-Postposing. *Linguistic Inquiry*, 7: 708–718.
- Marcus, G. (2013). Evolution, Memory, and the Nature of Syntactic Representation. In Bolhuis, J. and Everart, M. (eds.). *Birdsong, Speech and Language: Exploring the Evolution of Mind and Brain*. Cambs, Mass.: MIT Press.
- Marelj, M. (2002). Rules that Govern the Co-Occurrences of Theta Clusters. *Theoretical Linguistics*, 28(3): 357-373.
- Marelj, M. (2004). *Middles and Argument Structure Across Languages*. Ph.D Dissertation, University of Utrecht.
- Marelj, M. (2005). *Ditransitives and Conditions on Theta Clusters*. Guest Lecture, LSA Institute, MIT.
- Marois, R. and Ivanov, J. (2005). Capacity Limits of Information Processing in the Brain. *TRENDS in Cognitive Sciences*, 9(6): 296-305.
- Marr, D. (1982). *Vision: A Computational Investigation into the Human Representation and Processing of Visual Information*. New York: Freeman.
- Martinez, N. (2013). The Metaphoric Motivation of the Caused-Motion Construction: A Case Study of Perception. *International Journal of English Studies*, 13(1): 89-110.
- May, R. (1985). *Logical Form*. Cambs, Mass.: MIT Press.
- May, R. (1988). Ambiguities of quantification and *wh*: A reply to Williams. *Linguistic Inquiry*, 19: 118–135.
- Mazzo, V. Turatto, M. and Umiltà, C. (2005). Foreground-Background Segmentation and Attention: A Change Blindness Study. *Psychological Research*, 69(3): 201-210.
- Merchant, J. (2003). Sluicing. In Everaert, M., and van Riemsdijk, H. (Eds.). *The Syntax Companion*. London: Blackwell. pp. 269-289.

- Merchant, J. and Simpson, A. (2012). *Sluicing: Cross-Linguistic Perspectives*. *Oxford Studies in Theoretical Linguistics*, 38. Oxford: Oxford University Press.
- Merchant, J. (2013). Diagnosing Ellipsis. In Cheng, L. and Corver, N. (Eds.). *Diagnosing Syntax*. Oxford: Oxford University Press. pp. 537-542.
- Merlo, P. and Esteve Ferrer, E. (2006). The Notion of Argument in Prepositional Phrase Attachment. *Computational Linguistics*, 32: 341–377.
- Metzger, F. (1953). *Gesetze des Sehens*. Frankfurt-am-Main: Waldemar Kramer.
- Meyer W-U., Niepel, M., Rudolph, U., and A. Schützwohl. (1991). An Experimental Analysis of Surprise. *Cognition and Emotion*, 5: 295-311.
- Meyer, W-U., Reisenzein, R., and Schützwohl, A. (1997). Toward a Process Analysis of Emotions: The Case of Surprise. *Motivation and Emotion*, 21(3): 251-274.
- Michaelis, L. and Lambrecht, K. (1996). Toward a Construction- Based Theory of Language Function: The case of Nominal Extraposition. *Language*, 72: 215–247.
- Miller, E. and Cohen, J. (2001). An Integrative Theory of Prefrontal Cortex Function. *Annual Review of Neuroscience*, 24: 167-202.
- Miyake, A. and Shah, P. (1999). *Models of Working Memory: Mechanisms of Active Maintenance and Executive Control*. Cambridge: Cambridge University Press.
- Moltmann, F. and Szabolcsi, A. (1994). Scope Interactions with Pair-List Quantifiers. In *Proceedings of NELS*, 24: 381–395.
- Moscovitch, M. (1992). Memory and Working with Memory: A Component Process Model Based on Modules and Central Systems. *Journal of Cognitive Neuroscience*, 4: 257-267.
- Mulkern, A. (2007). Knowing Who's Important: Relative Discourse Saliency and Irish Pronominal Forms. In Hedberg, N. and Zacharski, R. (Eds.). *The Grammar-Pragmatics Interface: Essays in Honor of Jeanette K. Gundel*. Amsterdam: John Benjamins. pp. 113-142.
- Murgia, A. and Sharkey, P. (2009). Estimation of Distances in Virtual Environments Using Size Constancy. *The International Journal of Virtual Reality*, 8(1): 67–74.

- Myachykov, A. (2007). *Perception, Conceptualization, and Syntax in Sentence Production*. Ph.D Dissertation, University of Glasgow.
- Myachykov, A., Garrod, S., and Scheepers, C. (2012). Determinants of Structural Choice in Visually Situated Sentence Production. *Acta Psychologica*, 141: 304-315.
- Myachykov, A., Posner, M., and Tomlin, R. (2007). A Parallel Interface for Language and Cognition: Theory, Method, and Experimental Evidence. *The Linguistic Review*, 24: 457-475.
- Myachykov, A., Thompson, D., Scheepers, C., and S. Garrod. (2011). Visual Attention and Structural Choice in Sentence Production Across Languages. *Language and Linguistics Compass*, 5(2): 95-107.
- Nagy, A. and Sanchez, R. (1990). Critical Color Differences Determined with a Visual Search Task. *Journal of the Optical Society of America*, 7: 1209–1217.
- Nappa, R., January, D., Gleitman, L., and J. Trueswell. (2004). Paying Attention to Attention: Perceptual Priming Effects on Word Order. In *Proceedings of the 17th Annual CUNY Sentence Processing Conference*.
- Neeleman, A. and van de Koot. H. (2002). The Configurational Matrix. *Linguistic Inquiry*, 33: 529–574.
- Neeleman, A. and van de Koot, H. (2010). A Local Encoding of Syntactic Dependencies and its Consequences for the Theory of Movement. *Syntax*, 13: 331–372.
- Neeleman, A. and Weerman, F., (1999). *Flexible Syntax*. Dordrecht: Kluwer.
- Neisser, U. (1967). *Cognitive Psychology*. Englewood Cliffs: Prentice-Hall.
- New, J., Cosmides, L., and Tooby, J. (2007). Category-Specific Attention for Animal Reflects Ancestral Priorities, Not Expertise. *Proceedings of the National Academy of Sciences*, 104: 16598–16603.
- Oberauer, K. (2002). Access to Information in Working Memory: Exploring the Focus of Attention. *Journal of Experimental Psychology: Learning, Memory, and Cognition*, 28(3): 411-421.
- Oberauer K. (2013). The Focus of Attention in Working Memory: from Metaphors to Mechanisms. *Frontiers in Human Neuroscience*, 7: 673. [Online]. Available from: <http://www.ncbi.nlm.nih.gov/pmc/articles/PMC3797978/?report=reader>
- Oehrle, R. (1976). *The Grammatical Status of the English Dative Alternation*. Ph.D Dissertation, MIT.

- Olivers, C. (2009). What Drives Memory-Driven Attentional Capture? The Effects of Memory Type, Display Type, and Search Type. *Journal of Experimental Psychology: Human Perception and Performance*, 35(5): 1275-1291.
- Ono, H., Rogers, B. Ohmi, M., and M. Ono. (1988). Dynamic Occlusion and Motion Parallax in Depth Perception. *Perception*, 17(2): 255-266.
- Ooi, T., Wu, B., and He, Z. (2001). Distance Determined by the Angular Declination Below the Horizon. *Nature*, 414: 197-200.
- Osgood, C. and Bock, J. (1977). Salience and Sentencing: Some Production Principles. In Rosenberg, S. (Ed.), *Sentence Production*. New York: Lawrence Erlbaum Associates. pp. 89--140.
- Parkhurst, D., Law, K., and Niebur, E. (2002). Modelling the Role of Salience in the Allocation of Overt Visual Attention. *Vision Research*, 42: 107–123.
- Parsons, T. (1990) *Events in the Semantics of English: A Study in Subatomic Semantics*. Cambs, Mass.: MIT Press.
- Partee, B. (1965). *Subject and Object in Modern English*. New York: Garland.
- Pashler, H. (1994). Overlapping Mental Operations in Serial Performance with Preview. *Quarterly Journal of Experimental Psychology*, 47: 161-191.
- Perlmutter, D. and Postal, P. (1977). Toward a Universal Characterization of Passivization. *BLS*, 3: 394-417.
- Perlmutter, D. (1983). Personal and Impersonal Constructions. *Natural Language and Linguistic Theory*, 1: 141-200.
- Perlmutter, D. and Postal, P. (1983). Some Proposed Laws of Basic Clause Structure. In Perlmutter, D. (Ed.). *Studies in Relational Grammar I*. Chicago: University of Chicago Press. pp. 81-128.
- Pesetsky, D. (1995). *Zero Syntax: Experiencers and Cascades*. Cambs, Mass.: MIT Press.
- Peterson, T. (2013). *Rethinking Mirativity: The Expression and Implication of Surprise*. Ms. [Online]. Available from: http://semarch.linguistics.fas.nyu.edu/Archive/2FkYTg4O/Rethinking_Mirativity.pdf.
- Pinker, S. (1989). *Learnability and Cognition*. Cambs, Mass.: MIT Press.

- Pollard, C. and Sag, I. (1987). *An Information-Based Syntax and Semantics. Volume 1: Fundamentals. CSLI Lecture Notes Number 13.* Center for the Study of Language and Information, Leland Stanford Junior University.
- Posner, M. and Petersen, S. (1990). The Attention System of the Human Brain. *Annual Review of Neuroscience*, 13: 25-42.
- Pratt, J., Radulescu, P., Guo, R., and R. Abrams. (2010). It's Alive! Animate Motion Captures Visual Attention. *Psychological Science*, 21: 1724–1730.
- Preminger, O. (2006). *Argument Mapping and Extraction.* Masters Thesis, Tel Aviv University.
- Prince, E. (1992). The ZPG Letter: Subjects, Definiteness, and Information Status. In Thompson, S. and Mann, W. (Eds.). *Discourse Description: Diverse Analyses of a Fund Raising Text.* Amsterdam: John Benjamins. pp. 295-325.
- Proulx, M. (2010). Size Matters: Large Objects Capture Attention in Visual Search. *PLoS ONE*, 5(12): e15293. [Online]. Available from: http://webpace.qmul.ac.uk/mproulx/Proulx2010_PLoS ONE.pdf
- Pylyshyn, Z. and Storm, R. (1988). Tracking Multiple Independent Targets: Evidence for a Parallel Tracking Mechanism. *Spatial Vision*, 3: 179–197.
- Quirk, R., Greenbaum, S., Leech, G., and J. Svartvik. (1972). *A Grammar of Contemporary English.* London: Longman.
- Radford, A. (2004). *English Syntax: An Introduction.* Cambridge: Cambridge University Press.
- Rákosi, G. (2006). *Dative Experiencer Predicates in Hungarian.* Ph.D Dissertation, University of Utrecht.
- Ramchand, G. (2003). *First Phase Syntax.* Ms., University of Tromsø.
- Randall, J. (1992). The Catapult Hypothesis: An Approach to Unlearning. In Weissenborn, J. Goodluck, H. Roeper, T. (Eds.), *Theoretical Issues in Language Acquisition: Continuity and Change in Development.* Hillsdale, NJ: Lawrence Erlbaum. pp. 93-138.
- Rappaport Hovav, M., and Levin, B. (1998). Building Verb Meanings. In Butt, M and Geuder, W. (Eds.). *The Projection of Arguments: Lexical and Compositional Factors.* Stanford: CSLI Publications. pp. 97–134.

Rappaport Hovav, M. and Levin, B. (2004). Deconstructing Thematic Hierarchies. In Grimshaw, J., Maling, C., Simpson, J., and A. Zaenen. (Eds.). *Architecture, Rules, and Preferences: A Festschrift for Joan Bresnan*. Stanford: CSLI Publications. pp. 451-468.

Rappaport Hovav, M. and Levin, B. (2008). The English Dative alternation: The Case for Verb Sensitivity. *The Journal of Linguistics*, 44: 129-167.

Raymond, J., Shapiro, K., and Arnell, K. (1992). Temporary Suppression of Visual Processing in an RSVP Task: An Attentional Blink? *Journal of Experimental Psychology: Human Perception and Performance*, 18(3): 849-860.

Rayner, K. (1998). Eye Movements in Reading and Information Processing: 20 Years of Research. *Psychological Bulletin*, 85: 618-660.

Reinhart, T. (1976). *The Syntactic Domain of Anaphora*. Ph.D Dissertation, MIT.

Reinhart, T. (2000). The Theta System: Syntactic Realisations of Verbal Concepts. *UIL-OTS Working Papers*, University of Utrecht.

Reinhart, T. (2002). The Theta System: An Overview. *Theoretical Linguistics*, 28: 229-290.

Reisenzein, R., Meyer, W.-U., and Schützwohl, A. (1996). Reactions to Surprising Events: A Paradigm for Emotion Research. In Frijda, N. (Ed.). *Proceedings of the 9th conference of the International Society for Research on Emotions*. Toronto: ISRE. pp. 292- 296.

Rensink, R. (1997a). How Much of a Scene is Seen? The Role of Attention in Scene Perception. *Investigative Ophthalmology and Visual Science*, 38: s707.

Rensink, R. (2002). Change Detection. *Annual Review of Psychology*, 53: 245-277.

Rensink, R. (2005) Change Blindness. In Itti, L., Rees, G., and Tsotsos, J. (Eds). *Neurobiology of Attention*. San Diego, CA: Elsevier. pp. 76-81.

Rensink, R., O'Regan, J. and Clark, J. (1997). To See or not to See: The Need for Attention to Perceive Changes in Scenes. *Psychological Science*, 8: 368–373.

Richards, N. (1997). *What Moves Where When in Which Language?* Ph.D Dissertation, MIT.

Richards, W. and Miller, J. (1969). Convergence as a Cue to Depth. *Perception and Psychophysics*, 5(5): 317-320.

- Rissman, L. (2013). *Event Participant Representations and the Instrumental Role: a Cross-Linguistic Study*. Ph.D Dissertation, Johns Hopkins University.
- Román, A., El Fathi, A., and Santiago, J. (2013). Spatial Biases in Understanding Descriptions of Static Scenes: the Role of Reading and Writing Direction. *Memory and Cognition*, 41: 588-599.
- Rosenbach, A., (2005). Animacy Versus Weight as Determinants of Grammatical Variation in English. *Language*, 81: 613– 644.
- Rosenbach, A. (2008). Animacy and Grammatical Variation: Findings from English Genitive Variation. *Lingua*, 118: 151–171.
- Rosenbaum, P. (1967). *The Grammar of English Predicate Complement Constructions*. Cambs, Mass.: MIT Press.
- Ross, J. (1969). Guess who? In Binnick, R., Davison, A., Green, G., and J. Morgan (Eds.). *Papers from the 5th regional meeting of the Chicago Linguistic Society*. University of Chicago. pp. 252-286.
- Rubin, E. (1915). *Visuell Warhgenommene Figuren*. Copenhagen: Glydendalske.
- Rubin, E. (translated, 1958). Figure and Ground. In Beardslee, D. and Wertheimer, M. (Eds. and Trans.) *Readings in Perception*. New York: Van Nostrand. pp. 194–203.
- Rumelhart, D. and Ortony, A. (1977). The Representation of Knowledge in Memory. In Anderson, R., Spiro, R., and Montague, W. (Eds.). *Schooling and the Acquisition of Knowledge*. Hillsdale, NJ: Erlbaum. pp. 99-135.
- Sakas, W. (2000). Ambiguity and the Computational Feasability of Syntax Acquisition. Ph.D. Dissertation, City University of New York.
- Sakas, W. And Fodor, J. (2001). The Structural Triggers Learner. In Bertolo, S. (ed.). *Language Acquisition and Learnability*. Cambridge: Cambridge University Press. pp. 172-233.
- Salvagio, E., Cacciamani, L., and Peterson, M. (2012). Competition-Strength-Depended Ground Suppression in Figure-Ground Perception. *Attention, Perception, and Psychophysics*, 74: 964-978.
- Schneider-Zioga, P. (1988). *Wh-Questions in Kinande*. Ms. University of Southern California.
- Schütze, C. (1996). PP Attachment and Argumenthood. *MIT Working Papers in Linguistics*, 26: 95-151.

Schütze, C. (2012). Implementing Argumenthood Diagnostics for Prepositional Phrases: Comments on Merlo and Esteve Ferrer. Ms. UCLA.

Schutzwöhl, A. (1998). Surprise and Schema Strength. *Journal of Experimental Psychology: Learning, Memory, and Cognition*, 24(5): 1182-1199.

Schutzwöhl, A. and Borgstedt, K. (2005). The Processing of Affectively Valenced Stimuli: The Role of Surprise. *Cognition and Emotion*, 19(4): 583-600.

Sedgewick, H. (1986). Space Perception. In Boff, K., Kaufman, L., and Thomas J. (Eds.). *Handbook of Perception and Performance, Vol 1*. New York: Wiley. pp. 1-57.

Selkirk, E. (2008). Contrastive Focus, Givenness and the Unmarked Status of 'Discourse-New'. *Acta Hungarica Linguistica*, 55(3-4): 331-346.

Searle, J. (1983). *Intentionality*. Cambridge: Cambridge University Press.

Shallice, T. and Burgess, P. (1993). Supervisory Control of Action and Thought Selection. In Baddeley, A. and Weiskrantz, L. (Eds.). *Attention, Selection, Awareness, and Control: A Tribute to Donald Broadbent*. Oxford: Clarendon Press. pp. 171-187.

Shen, Y. (1985). *The Structure of Action in the Short Narrative Text*. Ph.D Dissertation, Tel Aviv University.

Slevc, R. (2011). Saying What's on Your Mind: Working Memory Effects on Sentence Production. *Journal of Experimental Psychology: Learning, Memory, and Cognition*, 37(6): 1503-1514.

Speas, M. (1990). *Phrase Structure in Natural Language*. Dordrecht: Kluwer.

Stroik, T. (1996). *Minimalism, Scope, and VP Structure*. Thousand Oaks: Sage Publications.

Styles, A. (2005). *Attention, Perception, and Memory: An Integrated Introduction*. Hove: Psychology Press.

Subirana-Vilanova, J., and Whitman, R. (1991). Perceptual Organisation, Figure-Ground, Attention, and Saliency: Figure Has a Fuzzy Boundary, Its Outside/Near/Top/Incoming Regions Are More Salient (or Not; or What?), and Wholes are Independent of the Whole. *Artificial Intelligence Memo*, 1218: MIT.

- Svenonius, P. (2007). Adpositions, Particles, and the Arguments They Introduce. In Reuland, E., Bhattacharya, T. and Spathas, G. (Eds.). *Argument Structure*. Amsterdam: John Benjamins. pp. 63-103.
- Theeuwes, J. (1992). Perceptual Selectivity of Color and Form. *Perception and Psychophysics*, 51: 599–606.
- Theeuwes, J. (1994). Stimulus-Driven Attentional Capture and Attentional Set: Selective Search for Color and Abrupt Onsets. *Journal of Experimental Psychology: Human Perception and Performance*, 20: 799–806.
- Theeuwes, J. (2004). Top-Down Strategies Cannot Override Attentional Capture. *Psychonomic Bulletin and Review*, 11: 65–70.
- Tomlin, R. (1997). Mapping Conceptual Representations into Linguistic Representations: The Role of Attention in Grammar. In Nuyts, J., and Pederson, E. (Eds.) *Language and Conceptualization*. Cambridge: Cambridge University Press. pp. 162-189.
- Treisman, A. and Gelade, G. (1980). A Feature Integration Theory of Attention. *Cognitive Psychology*, 12: 97–136.
- Treisman, A. (1986). Features and Objects in Visual Processing. *Scientific American*, 255(5): 114–125.
- Van Belle, W. and Langendonck, W. (1996). *The Dative, Volume 1: Descriptive Studies*. Amsterdam: John Benjamins.
- Van der Leek, F. (1996). Rigid Syntax and Flexible Meaning: The Case of the English Ditransitive. In Goldberg, A. (Ed.). *Conceptual Structure, Discourse and Language*. Stanford: CSLI Publications. pp. 321-332.
- Van Dijck J.P., Abrahamse, E., Majerus, S., and W. Fias (2013). Spatial Attention Interacts with Serial-Order Retrieval from Verbal Working Memory. *Psychological Science*, 24(9) 1854–1859.
- Van Dijck, J. and Fias, W. (2011). A Working Memory Account for Spatial-Numerical Associations. *Cognition*, 119(1): 114-119.
- Van Valin, R. (1990). Semantic Parameters of Split Intransitivity. *Language*, 66(2): 221-260

- Van Valin, R. and Wilkins, D. (1996). The Case for 'Effector': Case Roles, Agents, and Agency Revisited. In: Shibatani M. and Thompson S. (Eds.). *Grammatical Constructions*. Oxford: Clarendon Press. pp. 289-322.
- Vecera, S., Flevaris, A., and Filapek, J. (2004). Exogenous Spatial Attention Influences Figure-Ground Assignment. *Psychological Science*, 15(1): 20-26.
- Vecera, S. and O'Reilly, R. (1998). Figure-Ground Organization and Object Recognition Processes: An Interactive Account. *Journal of Experimental Psychology: Human Perception and Performance*, 24: 441-462.
- Vecera, S. and O'Reilly, R. (2000). Graded Effects in Hierarchical Figure-Ground Organization: Reply To Peterson (1999). *Journal of Experimental Psychology: Human Perception and Performance*, 26: 1221-1230.
- Vecera, S., Vogel, E., and Woodman, G. (2002). Lower Region: A New Cue for Figure-Ground Segregation. *Journal of Experimental Psychology: General*, 131: 194-205.
- Vogels, J., Krahmer, E., and Maes, A. (2013). Who is Where Referred to How, and Why? The Influence of Visual Saliency on Reference Accessibility in Spoken Language Production. *Language and Cognitive Processes*, 28(9): 1323-1349.
- Wasow, T. (1977). Transformations and the Lexicon. In Culicover, P., Wasow, T., and Akmajian, A. (Eds.). *Formal syntax*. New York: Academic Press. pp. 327-360
- Wasow, T. (1997). End-Weight from the Speaker's Perspective. *Journal of Psycholinguistic Research*, 26: 347-361.
- Wasow, T. and Arnold, J. (2003). Post-Verbal Constituent Ordering in English. *Topics in English Linguistics*, 43: 119-154.
- Wierzbicka, A. (1988). *The Semantics of Grammar*. Amsterdam: John Benjamins.
- Williams, E. (1984). Grammatical Relations. *Linguistic Inquiry*, 15: 639-674.
- Williams, E. (1997). Blocking and Anaphora. *Linguistic Inquiry*, 28: 577-617.
- Wind Cowles, H., and Ferreira, V. (2012). The Influence of Topic Status on Written and Spoken Sentence Production. *Discourse Processes*, 49(1): 1-28.

Wolfe, J. (1998a). Visual Search. In Pashler, H. (Ed.). *Attention*. Hove, East Sussex: Psychology Press Ltd. pp. 13–74.

Woolford, E. (2006). Lexical Case, Inherent Case, and Argument Structure. *Linguistic Inquiry*, 37(1): 111-130.

Yang, J., Wang, A., Yan, M., Zhu, Z., Chen, C., and Y. Wang. (2012). Distinct Processing for Pictures of Animals and Objects: Evidence from Eye Movements. *Emotion*, 12: 540–551.

Yantis, S. (1993). Stimulus-Driven Attentional Capture and Attentional Control Settings. *Journal of Experimental Psychology: Human Perception and Performance*, 19: 676–681.

Yantis, S. and Jonides, J. (1984). Abrupt Visual Onsets and Selective Attention: Evidence from Visual Search. *Journal of Experimental Psychology: Human Perception and Performance*, 10: 610–621.

Young, R. and Morgan, W. (1987). *The Navajo Language: A Grammar and Colloquial Dictionary*. Albuquerque: University of New Mexico Press.

APPENDICES

Appendix 1: Baseline survey

- (1) Which sentence do you prefer?
 - a. Mary kissed the boys often.
 - b. Mary often kissed the boys.
- (2) Which sentence do you prefer?
 - a. Peter splashed paint on desks.
 - b. Peter splashed desks with paint.
- (3) Which sentence do you prefer?
 - a. The trainer tossed the fish to the seal.
 - b. The trainer tossed the seal the fish.
- (4) Which sentence do you prefer?
 - a. Tom is different to Tim.
 - b. Tom is different from Tim.
- (5) Which sentence do you prefer?
 - a. I have just got home.
 - b. I just got home.
- (6) Which sentence do you prefer?
 - a. Bill packed jars with jam.
 - b. Bill packed jam into jars.
- (7) Which sentence do you prefer?
 - a. Richard showed the painting to the camera.
 - b. Richard showed the camera the painting.
- (8) Which sentence do you prefer?
 - a. Mary has a barking dog.
 - b. Mary has a dog that barks.
- (9) Which sentence do you prefer?
 - a. John handed the villain to the police.
 - b. John handed the police the villain.
- (10) Which sentence do you prefer?
 - a. We are on holiday from the 10th to the 17th.
 - b. We are on holiday from the 10th through the 17th.

- (11) Which sentence do you prefer?
- The waiter laid tables with cutlery.
 - The waiter laid cutlery on tables.
- (12) Which sentence do you prefer?
- The nurse brought the doctor the patient.
 - The nurse brought the patient to the doctor.
- (13) Which sentence do you prefer?
- The motorbike caught up to the car.
 - The motorbike caught up with the car.
- (14) Which sentence do you prefer?
- John is the man we expected to see.
 - John is the man that we expected to see.
- (15) Which sentence do you prefer?
- The hunter threw the rabbit to the hound.
 - The hunter threw the hound the rabbit.
- (16) Which sentence do you prefer?
- Bill, everyone likes.
 - Bill, everyone likes him.
- (17) Which sentence do you prefer?
- To boldly go.
 - To go boldly.
- (18) Which sentence do you prefer?
- Charlie loaded aeroplanes with luggage.
 - Charlie loaded luggage onto aeroplanes.
- (19) Which sentence do you prefer?
- Max gave smoking up last month.
 - Max gave up smoking last month.
- (20) Which sentence do you prefer?
- They didn't see anyone in the house.
 - They saw no one in the house.
- (21) Which sentence do you prefer?
- To regularly interrupt a teacher is rude.
 - To interrupt a teacher regularly is rude.

- (22) Which sentence do you prefer?
- a. The librarian stacked shelves with books.
 - b. The librarian stacked books onto shelves.
- (23) Which sentence do you prefer?
- a. Are the keys to the car in your pocket?
 - b. Is the keys to the car in your pocket.
- (24) Which sentence do you prefer?
- a. I have just seen Jane.
 - b. I saw Jane just now.
- (25) Which sentence do you prefer?
- a. The data is important.
 - b. The data are important.
- (26) Which sentence do you prefer?
- a. A helicopter, most people don't have.
 - b. A helicopter, most people don't have one.
- (27) Which sentence do you prefer?
- a. Sophie piled bricks onto tables.
 - b. Sophie piled tables with bricks.
- (28) Which sentence do you prefer?
- a. Who did you smile at?
 - b. At who did you smile?
- (29) Which sentence do you prefer?
- a. At what did you look?
 - b. What did you look at?
- (30) Which sentence do you prefer?
- a. The nurse passed the infant to the parent.
 - b. The nurse passed the parent the infant.

Appendix 2. Experiment 1 data – spray/load alternation responses

PARTICIPANT	AGE RANGE	NATIONALITY	VERB SET: SPRAY/LOAD							TOTALS: TARGET RESPONSE	
										LOCATIVE	WITH-VARIANT
1	B	BR	1	0	1	0	1	0	0	3	3
2	C	BR	0	1	0	0	0	0	1	4	2
3	C	NON	1	0	0	0	0	0	0	5	1
4	C	BR	1	1	1	1	0	0	0	2	4
5	D	NON	0	1	1	0	0	0	0	4	2
6	E	NON	0	1	1	0	0	0	0	4	2
7	B	BR	0	0	0	0	1	0	0	5	1
8	A	BR	1	1	0	0	1	0	0	3	3
9	B	BR	0	1	0	0	1	0	0	4	2
10	D	NON	1	1	0	0	1	0	0	3	3
11	E	NON	0	1	0	0	0	0	0	5	1
12	B	BR	0	0	1	0	1	0	0	4	2
13	C	BR	0	1	0	0	1	0	0	4	2
14	B	BR	0	0	0	1	0	0	0	5	1
15	A	BR	1	1	1	0	1	0	0	2	4
16	B	BR	1	0	1	0	0	0	0	4	2
17	D	NON	0	0	0	0	1	0	0	5	1
18	B	BR	0	0	0	0	1	0	0	5	1
19	A	BR	0	0	0	0	0	0	0	6	0
20	C	NON	0	1	1	0	0	0	0	4	2
21	E	NON	0	1	0	0	0	0	0	5	1
22	B	NON	1	0	0	0	1	0	0	4	2
23	E	NON	0	1	0	0	0	0	0	5	1
24	A	BR	0	1	1	0	0	0	0	4	2
25	A	BR	0	0	1	0	0	0	0	5	1
26	D	NON	0	0	0	0	0	0	0	6	0
27	E	BR	0	1	0	0	0	0	0	5	1
28	B	BR	0	0	1	0	0	0	0	5	1
29	C	BR	1	0	0	0	0	0	0	5	1
30	C	BR	1	1	1	0	0	0	0	3	3
31	A	BR	0	0	0	0	1	1	0	4	2
32	B	NON	0	0	1	0	0	1	0	4	2
33	A	BR	0	1	0	0	0	0	0	5	1
34	B	BR	1	0	1	0	1	1	0	2	4
35	C	BR	1	0	0	0	1	0	0	4	2
36	C	NON	0	1	1	0	1	0	0	3	3
37	A	BR	0	0	0	1	0	0	0	5	1
38	E	BR	0	1	1	1	0	1	0	2	4
39	A	BR	0	0	0	1	1	0	0	4	2
40	B	BR	1	1	0	0	1	0	0	3	3
41	B	BR	0	0	0	0	0	0	0	6	0
42	B	BR	1	0	0	0	1	0	0	4	2
43	A	BR	0	0	0	0	1	1	0	4	2
44	A	BR	0	0	0	1	0	1	0	4	2
45	C	BR	0	1	1	0	0	1	0	3	3
46	B	NON	1	0	0	0	0	0	0	5	1
47	A	BR	0	0	0	0	0	0	0	6	0
48	C	BR	0	0	1	0	0	0	0	5	1
49	A	BR	0	0	0	0	0	0	0	6	0
50	A	BR	1	1	0	0	0	0	0	4	2
51	B	BR	1	0	0	0	0	1	0	4	2
52	C	NON	0	0	0	0	0	0	0	6	0
53	B	BR	0	0	1	0	1	1	0	3	3
54	B	BR	0	1	0	0	0	0	0	5	1
55	A	BR	0	0	0	0	0	0	0	6	0
56	A	BR	0	1	0	0	1	0	0	4	2
57	A	BR	0	0	0	0	0	0	0	6	0
58	A	BR	0	0	0	0	0	0	0	6	0
59	C	BR	1	0	0	1	1	0	0	3	3
60	B	BR	0	0	0	0	0	0	0	6	0
61	B	NON	0	0	1	0	0	0	0	5	1
62	D	BR	0	1	1	0	0	0	0	4	2

KEY		
Nationality	BR = British	NON = non-British
Age range	A = 18-30	B = 31-40
	C = 41-50	D = 51-60
	E = 60+	
Responses	1 = with-variant	0 = locative

Totals							
WITH-VARIANT	18	25	21	7	22	10	103
LOCATIVE	44	37	41	55	40	52	269

Appendix 3. Experiment 1 data – dative alternation responses

PARTICIPANT	AGE RANGE	NATIONALITY	VERB SET: DATIVE						TOTALS: TARGET RESPONSE	
									DATIVE	DOUBLE OBJECT
1	B	BR	0	1	0	0	1	0	4	2
2	C	BR	0	0	0	0	0	0	6	0
3	C	NON	0	1	0	0	0	0	5	1
4	C	BR	0	1	1	1	1	0	2	4
5	D	NON	0	1	0	1	0	0	4	2
6	E	NON	0	0	0	0	0	0	6	0
7	B	BR	1	0	0	0	0	0	5	1
8	A	BR	0	0	0	0	0	0	6	0
9	B	BR	0	0	0	0	0	0	6	0
10	D	NON	0	1	0	0	0	0	5	1
11	E	NON	0	0	0	0	0	0	6	0
12	B	BR	1	0	0	0	0	0	5	1
13	C	BR	0	0	0	0	0	0	6	0
14	B	BR	0	0	0	0	0	0	6	0
15	A	BR	1	0	0	1	0	0	4	2
16	B	BR	0	0	0	0	0	0	6	0
17	D	NON	0	0	0	0	0	0	6	0
18	B	BR	0	0	0	0	0	0	6	0
19	A	BR	0	0	0	0	0	0	6	0
20	C	NON	0	0	0	0	0	0	6	0
21	E	NON	0	0	0	0	1	0	5	1
22	B	NON	0	0	1	0	0	0	5	1
23	E	NON	0	0	0	0	0	0	6	0
24	A	BR	0	0	0	1	1	0	4	2
25	A	BR	0	0	0	1	1	1	3	3
26	D	NON	0	0	0	0	0	0	6	0
27	E	BR	0	0	0	0	0	0	6	0
28	B	BR	1	0	0	0	0	0	5	1
29	C	BR	0	0	0	0	0	0	6	0
30	C	BR	0	1	0	0	0	0	5	1
31	A	BR	1	0	1	0	0	0	4	2
32	B	NON	0	0	0	1	1	0	4	2
33	A	BR	0	1	0	1	0	0	4	2
34	B	BR	0	0	0	0	0	0	6	0
35	C	BR	0	1	0	0	1	0	4	2
36	C	NON	0	0	0	0	0	0	6	0
37	A	BR	0	0	0	0	0	0	6	0
38	E	BR	0	0	0	0	0	0	6	0
39	A	BR	0	0	0	0	0	0	6	0
40	B	BR	1	1	0	1	0	0	3	3
41	B	BR	0	0	0	0	0	0	6	0
42	B	BR	0	0	0	0	0	0	6	0
43	A	BR	0	1	1	1	1	1	1	5
44	A	BR	1	0	0	0	0	1	4	2
45	C	BR	0	0	0	0	0	0	6	0
46	B	NON	0	0	0	0	0	0	6	0
47	A	BR	0	0	1	0	0	0	5	1
48	C	BR	0	0	0	0	0	0	6	0
49	A	BR	1	1	0	0	0	0	4	2
50	A	BR	0	0	0	0	1	1	4	2
51	B	BR	1	0	0	0	0	0	5	1
52	C	NON	1	1	0	0	0	0	4	2
53	B	BR	0	0	0	0	0	0	6	0
54	B	BR	0	0	0	0	0	0	6	0
55	A	BR	1	1	1	1	1	1	0	6
56	A	BR	1	0	0	0	0	0	5	1
57	A	BR	0	0	0	0	0	0	6	0
58	A	BR	0	1	0	0	0	0	5	1
59	C	BR	0	0	0	0	0	0	6	0
60	B	BR	0	1	1	0	0	0	4	2
61	B	NON	0	0	0	0	0	0	6	0
62	D	BR	0	0	0	1	0	0	5	1

KEY		
Nationality	BR = British	NON = non-British
Age range	A = 18-30	B = 31-40
	C = 41-50	D = 51-60
	E = 60+	
Responses	1 = double object	0 = dative

Totals								
Double Object	12	15	7	11	10	5		60
Dative	50	47	55	51	52	57	312	

Appendix 6. Experiment 1: Post-debrief consent and information sheet

Post-Debrief Consent Form for Deception study

Establishing a baseline preference for the dative and spray/load alternations.

Thank you for your participation. During the experiment, you were asked to choose your preferred sentence or phrase from a series of sentence and phrase pairs. You were told that the purpose of the study was to examine regional preferences for different kinds of sentence and phrase constructions. Even though this is itself an interesting research question, this was not the true purpose of the study. The purpose of the study was to examine a general preference in just two types of sentence pairs given below. (1) is known as the dative alternation, and (2) is known as the spray/load alternation.

- (1) a. Sarah will feed the zebra to the lion.
- b. Sarah will feed the lion the zebra.
- (2) a. Sarah will load luggage onto aeroplanes.
- b. Sarah will load aeroplanes with luggage.

I believe that there is a general default preference for one of the constructions in each of the alternations (the (a) examples). The reason for the deception is that it was considered that your behaviour would be adversely affected by an awareness of the actual task, and this may have had implications for the choices you make.

Because you were deceived, you now have the right to refuse to allow your responses and your personal data to be used, and to ask that they be destroyed immediately. If you do so, there is no penalty.

If you do wish your information to be removed from the study then please place an X in this box.

Appendix 7. Critical images

Images for dative alternation.

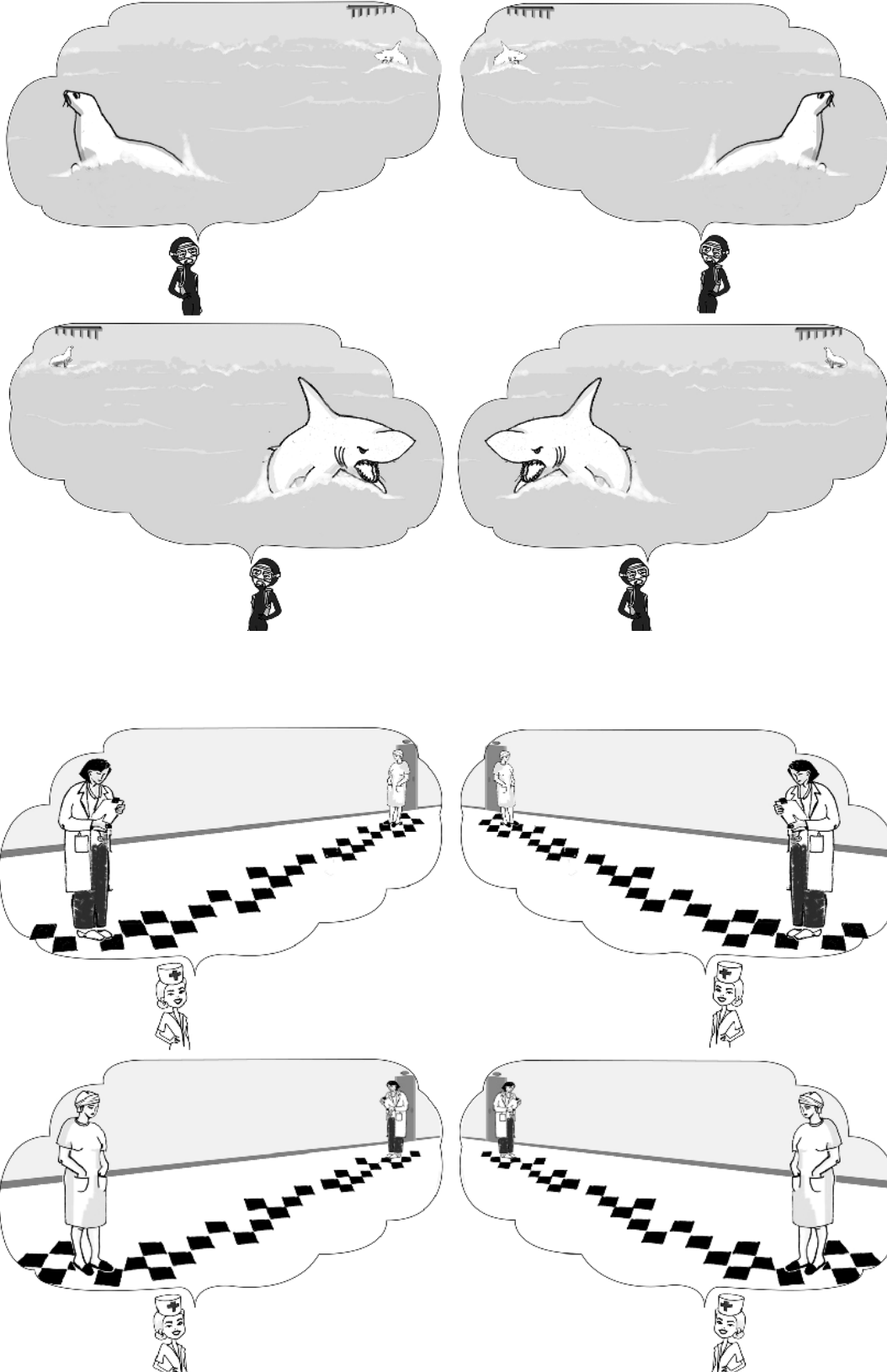

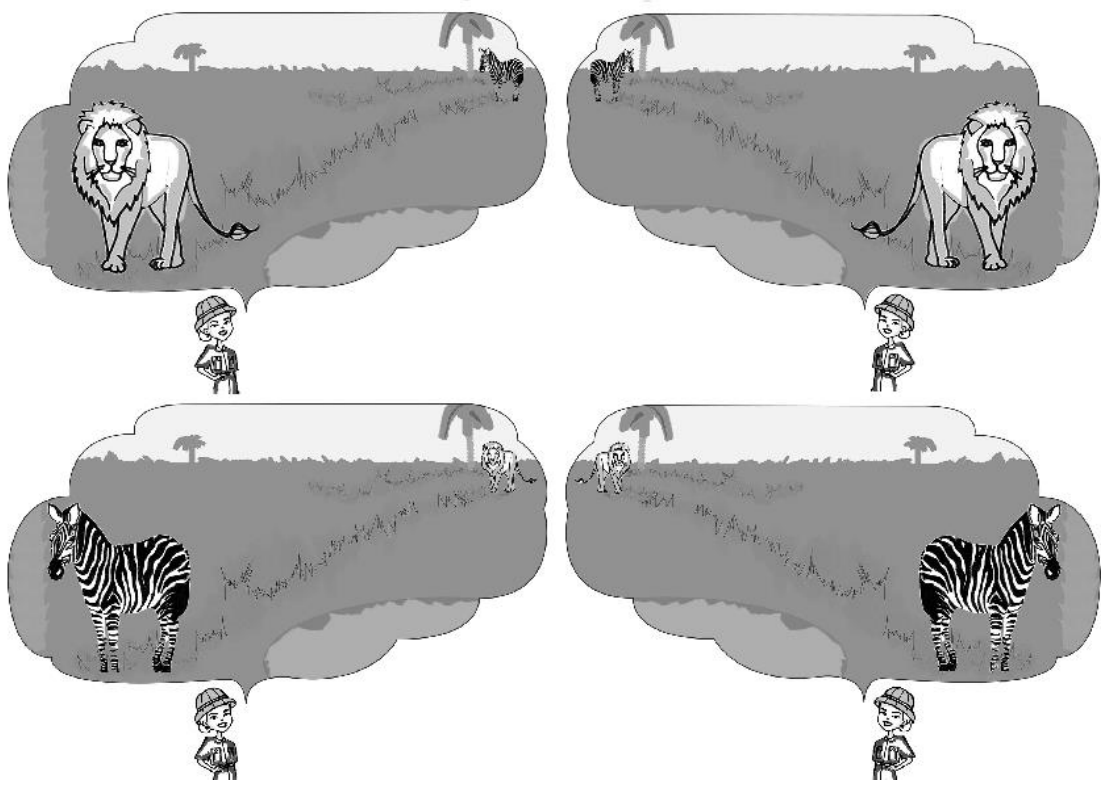

Images for spray/load alternation.

