



# Kent Academic Repository

**Bothwell, Keith and Watkins, Richard (2015) *Pines Calyx Earth Tube Performance*.  
In: PLEA 2015 Proceedings. .**

## Downloaded from

<https://kar.kent.ac.uk/53216/> The University of Kent's Academic Repository KAR

## The version of record is available from

## This document version

UNSPECIFIED

## DOI for this version

## Licence for this version

UNSPECIFIED

## Additional information

## Versions of research works

### Versions of Record

If this version is the version of record, it is the same as the published version available on the publisher's web site. Cite as the published version.

### Author Accepted Manuscripts

If this document is identified as the Author Accepted Manuscript it is the version after peer review but before type setting, copy editing or publisher branding. Cite as Surname, Initial. (Year) 'Title of article'. To be published in *Title of Journal*, Volume and issue numbers [peer-reviewed accepted version]. Available at: DOI or URL (Accessed: date).

### Enquiries

If you have questions about this document contact [ResearchSupport@kent.ac.uk](mailto:ResearchSupport@kent.ac.uk). Please include the URL of the record in KAR. If you believe that your, or a third party's rights have been compromised through this document please see our [Take Down policy](https://www.kent.ac.uk/guides/kar-the-kent-academic-repository#policies) (available from <https://www.kent.ac.uk/guides/kar-the-kent-academic-repository#policies>).

# Kent Academic Repository

## Full text document (pdf)

### Citation for published version

Bothwell, Keith and Watkins, Richard (2015) Pines Calyx Earth Tube Performance. In: PLEA 2015 31st International Conference, Bologna, 9-11 September 2015, Bologna.

### DOI

### Link to record in KAR

<http://kar.kent.ac.uk/53216/>

### Document Version

UNSPECIFIED

#### Copyright & reuse

Content in the Kent Academic Repository is made available for research purposes. Unless otherwise stated all content is protected by copyright and in the absence of an open licence (eg Creative Commons), permissions for further reuse of content should be sought from the publisher, author or other copyright holder.

#### Versions of research

The version in the Kent Academic Repository may differ from the final published version.

Users are advised to check <http://kar.kent.ac.uk> for the status of the paper. **Users should always cite the published version of record.**

#### Enquiries

For any further enquiries regarding the licence status of this document, please contact:

[researchsupport@kent.ac.uk](mailto:researchsupport@kent.ac.uk)

If you believe this document infringes copyright then please contact the KAR admin team with the take-down information provided at <http://kar.kent.ac.uk/contact.html>

## PINES CALYX EARTH TUBE PERFORMANCE

Keith Bothwell	Kent School of Architecture, University of Kent, Canterbury, UK	k.bothwell@kent.ac.uk
Richard Watkins	Kent School of Architecture	



Fig 1: The Pines Calyx building in its coastal setting

---

### Research summary

In temperate climates earth tubes achieve increased comfort in summer and the pre-heating of inlet air in winter, reducing the requirement for cooling and heating. This strategy was adopted to pre-temper air entering a small conference centre building in Kent, UK. The earth tube is about 16m long comprising a concrete pipe with an internal diameter of 0.6m. The pipe is located approximately 1.5m below ground level. A very low energy fan at the outlet end draws air through the tube and pushes it through a heat exchanger before it is distributed via ducts in the building. This paper reports on the results of monitoring the earth tube temperatures and air velocities under different weather conditions. Temperature sensors were positioned externally and at both ends of the earth tube. An anemometer was fixed in place 4m from the inlet end. This 'fixed' anemometer in the earth tube was calibrated and the velocity profile of the air flow in the tube was established. The air in the tube was found to have an almost uniform velocity profile, which is likely to be caused by the considerable turbulence created by changes in the direction of the tube, and the dimensions of the pipe relative to the flow rate. This indicates that the system was well-designed to maximise the heat exchange potential of the duct. The energy contribution of the earth in pre-heating and pre-cooling the air has been calculated at approximately 500W for each degree Kelvin raised or lowered, compared to only 18W power consumed by the fans. This demonstrates that earth tubes can make a very significant contribution to providing heating and cooling, with very low carbon emissions. Earth tubes are a durable and low-cost method of providing resilience in the face of climate change.

**Keywords:** earth tubes, earth cooling, passive design, low energy design, natural ventilation, Passivhaus principles, hybrid systems, mixed-mode systems

## 1. Introduction

The Pines Calyx is an innovative low-energy building located in St Margaret's Bay, Kent, on the south coast of the UK. The building is located in a parkland setting and was completed in 2006.

The energy strategy for the building is founded on passive design principles, based on the Passivhaus standard. The building has very high levels of insulation, air-tight construction, mechanical ventilation heat recovery (MVHR), and an earth tube.

The building comprises two main conference spaces, called 'roundels' because they are circular in form. The roundels have circular rooflights at their centre, called oculi. There are ancillary spaces for bar, kitchen, WCs and a plant room. The gross floor area is approximately 400 m<sup>2</sup>.

Innovative sustainable construction techniques include rammed chalk walls made with material excavated on site, and gustavino-vaulted roofs/ceilings, constructed from tiles manufactured locally from waste clay.

In 2012 a successful application was made by the author to the UK's Technology Strategy Board for the monitoring of the building's performance under its Building Performance Evaluation (BPE) programme. The two-year programme of work commenced in September 2012 and was completed in October 2014. The work included thermal imaging and daylight surveys, as well as the monitoring of temperatures and humidity at various points: externally, within the main spaces of the building and within the earth tube. Air velocities, energy consumption, insolation and other data was collected.

This paper focusses on the performance of the earth tube.

## 2. Design

### 2.1 Earth tube design principle

The design intention for the earth tube was that it would pre-heat fresh air in winter, to reduce heating costs and carbon emissions, and cool fresh air in summer, to improve comfort without the need for air-conditioning.

This was based on the knowledge that the ground temperature at a certain depth below ground level is very stable and approximates to the average annual external temperature. The depth at which the ground temperature is stable varies according to soil type and moisture content. "Usually systems buried to a depth of 2–4 m give the best economic return without incurring prohibitive excavation costs (CIBSE, 2005)." Along the south coast of the UK, the average external temperature is approximately 11°C. (Met Office)

As the inlet air passes through the earth tube it exchanges heat with the ground via the wall of the tube. If turbulence within the tube can be achieved (through changes in tube direction and/or surface irregularities in the tube wall and/or baffles to deflect air within the tube) then the heat exchange is enhanced. A detailed review of the design parameters for earth tubes has been discussed in De Paepe & Janssens (2003). If turbulence is not achieved a more laminar flow results, with a much greater radial velocity gradient and slower moving air adjacent to the inner wall of the tube - reducing the heat exchange effects.



Fig 2: Cowl above inlet to earth tube

## 2.2 Earth tube design

The earth tube is approximately 16m in length overall and comprises a concrete pipe with an internal diameter of 0.6m and a wall thickness of 100mm. The pipe is located approximately 1.5m below ground level. The tube inlet is connected to a manhole (see Fig 4). The manhole is capped with a ventilating cowl structure fabricated from timber and incorporating spiral shaped openings on all sides (see Fig 3). Insect mesh covers all the inlet openings. The tube terminates below ground level internally with a fan, which pushes air first through the heat exchanger in the plant room, and then to the building.

The two low-energy fans are 24V DC 82W made by EBM in Germany. The heat exchanger is reused from another building, and comprises a box containing glass tubes. The box has a clear plastic face to front, so that the internal arrangement is visible. The intake air from the earth tube passes through the glass tubes in the heat exchanger and then through distribution ductwork to the two roundels. Air is extracted at high level adjacent to the oculi, and from the WCs and kitchen and bar room by passing through ducts and then back through the heat exchanger in the opposite direction. The extract air passes through the space in the box surrounding the glass tubes, pre-heating

the intake air. The extract air is pulled through the heat exchanger by a second fan, located in a duct which extracts through the roof.

The oculi in the roundels were designed to be openable, to vent off excess hot air when required, but have not yet been made operable.

Intake and extract fan speeds are set independently by two variable speed controllers located in the plant room. These are manually adjusted.



Fig 3: The air inlet terminal above the manhole



Fig 4: Junction of manhole and earth tube



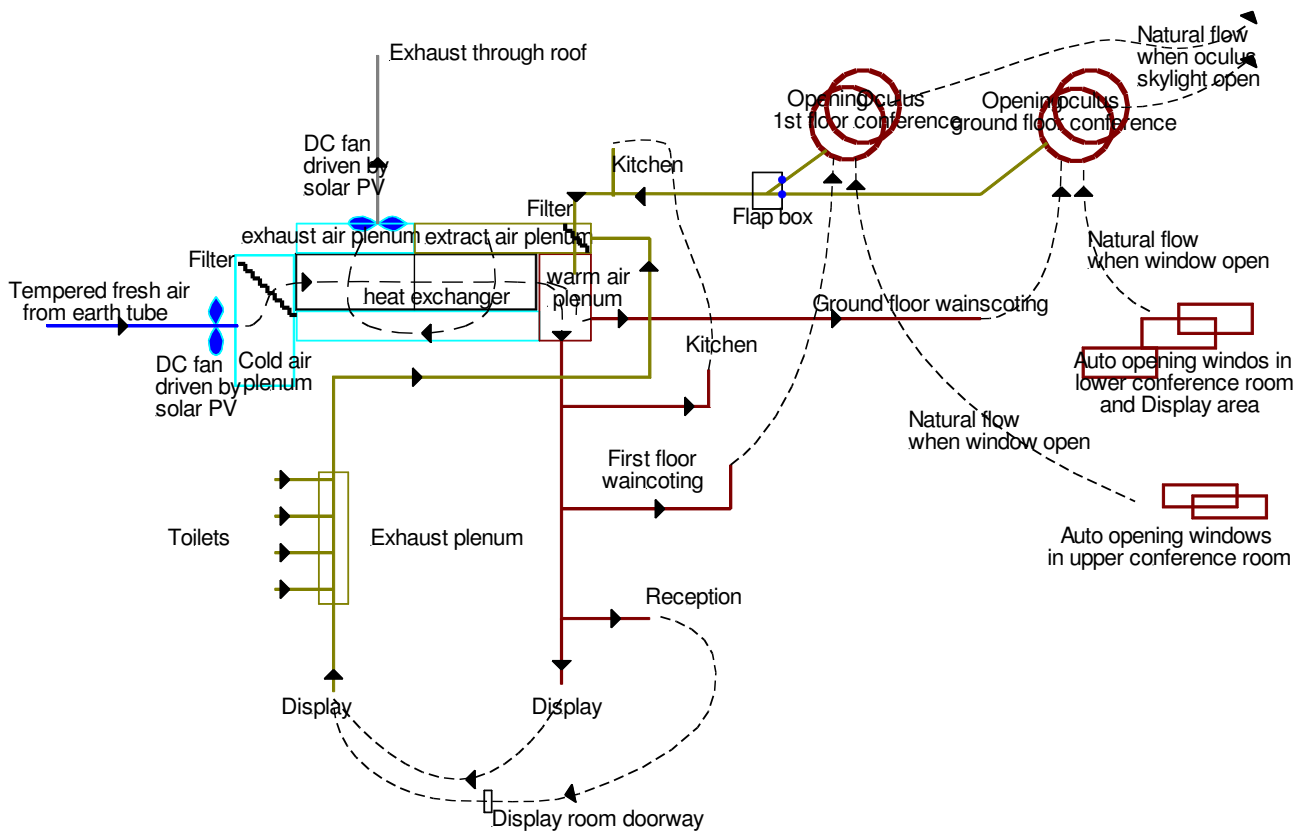

Fig 5: Ventilation system schematic

### 3. Research objectives

The objectives of this part of the monitoring exercise - relating to the earth tube - were firstly to determine the cooling and heating effects of the earth tube itself and, secondly, to compare the power of these effects with the power being used to drive the fans. A further objective was to determine the efficacy of the tube in improving internal comfort conditions in the roundels during warm weather.

### 4. Method

Sensors are located in the following locations (amongst others in the building):

- T-air (°C) and %RH externally (below the solar panel array)

- T-air (°C) and %RH at the inlet to the earth tube (external, below cowl)
- T-air (°C) and %RH at the outlet of the earth tube (0.3m before air is extracted through the fan into the building)
- V (m/s) anemometer located at a point central within the earth tube approximately 3.8m from the inlet end.

A CT current sensor is located on the distribution circuit serving the two low voltage fans (amongst many other circuits serving the building) - in the earth tube and in the outlet duct.

Data from all the sensors is logged every 15 minutes locally and is uploaded to a resilient data centre in the cloud on a daily basis.

#### 4.1 Earth tube velocity profile

In April 2014 a TSI Airflow TA465 hot-wire anemometer was used to calibrate the data from the fixed anemometer within the earth tube (see Fig 6). The team also measured the velocity profile of the tube so that the volume of air flow could be calculated, based on the velocity at the centre of the duct. Velocity measurements were taken using the TSI hot-wire anemometer at these points:

- Centre of tube
- 100 mm from centre
- 200 mm from centre
- 250 mm from centre



Fig 6: The 'permanent' or fixed anemometer in the tube

Unusually for a ventilation duct, the earth tube has an almost uniform velocity profile. A profile with a distinctly higher velocity at the centre reducing towards the walls of the tube is more usual within ventilation ducts. The more uniform profile is likely to be due to the turbulence caused by the changes in angle within the tube, and the dimensions of the pipe relative to the flow rate, indicating that the system has been well-designed to maximise the heat exchange potential of the duct.

The intake fan is normally set to mid speed and typical velocities in the earth tube are around 1.5 m/s. These velocities vary little because the fan speed is manually set and is rarely changed.



Fig 7: Fan control panel

## 5. Results

Data collected in April, May and August 2013, and January 2014 has been reviewed.

Fig 8 shows data over three days on 4 April and 5 April and 7 May 2013 (at 15 minute intervals). The jump in the graph occurs when the date changes from 5 April to 7 May.

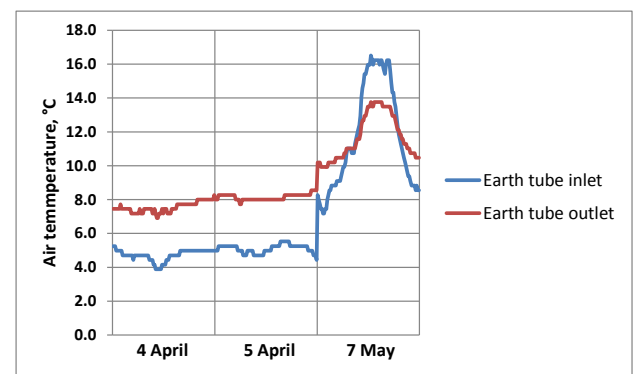

Fig 8: Temperatures in the earth tube on 4 April, 5 April and 7 May 2013

The temperature difference within the earth tube ranged from 2K to 4.3K between the external and internal temperatures, except when the external temperature approaches the ground temperature (11-12°C). This shows the earth tube pre-heating the air by 2-3K when the external temperature is below approximately 10°C and cooling the air by a similar amount when the external temperature is above approximately 14°C.

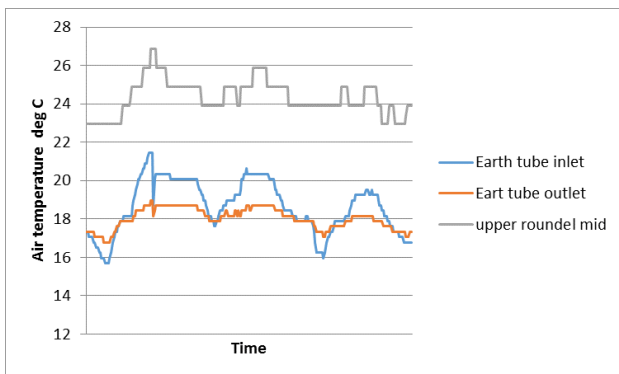

Fig 9: Temperatures over three days, from 1-3 August 2013

If these results are compared with those for the hottest time of year (see Fig 9) when the highest external temperatures were recorded at the beginning of August 2013, the results are rather less conclusive. Notably there is no cooling effect when the external temperature falls towards 17.5 degrees or below. This can be explained by the earth tube heating up over a period of warm days so that it no longer has the same cooling capacity that it does in winter or spring.

Figure 9 shows the earth tube external and internal temperatures compared with upper roundel mid level temperature. Temperatures at the external end of the earth tube ranged from 15.7°C to 21.5°C and at the internal end from 16.8°C to 19°C. Maximum cooling of 2.7 °K was achieved. The temperature stabilising effect of the earth tube can easily be seen. However, this stabilising effect is not

transferred into the upper roundel, where the temperature profile mirrors the external temperature fairly directly.

Compare this with one of the coolest periods of the year, from 21-23 January 2014 inclusive (Fig 10).

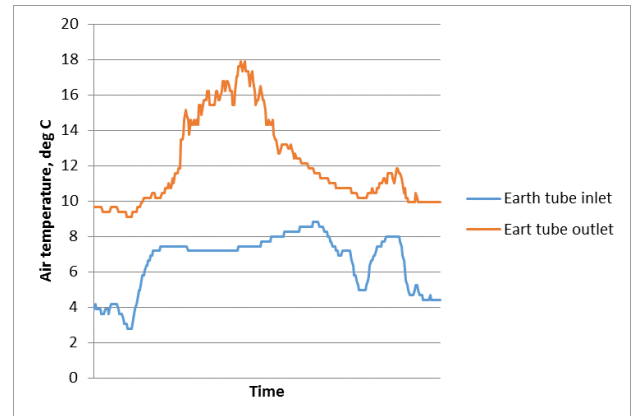

Fig 10: Temperatures over 3 days, from 21-23 January 2014

This suggests a very significant heating effect in the earth tube varying from 2.7K up to 10.4 K, which is very significant and highly unexpected. However, further investigation reveals that the air velocity in the earth tube was much lower during this period (from 12:00 on 14 January to 13:45 on 18 February 2014), at 0.016m/s, compared to an overall average velocity in the earth tube of 0.239 m/s. This strongly suggests that the intake fan was switched off during that period. It is not possible to verify this conclusively as both intake and extract fans are on the same metered circuit.

The raised temperatures can be attributed to heat from the building raising the temperature at the outlet end of the earth tube, while velocities within the earth tube were extremely low.

A further winter period has therefore been selected, from 4 to 5 January 2014 (see Fig 11), during which air velocities in the earth tube



were more normal (average 1.06 m/s). This shows results that might be anticipated - 3K of warming when the external temperatures were very low (less than 4 deg C) and a much smaller temperature difference as the inlet temperature approaches 10 deg C.

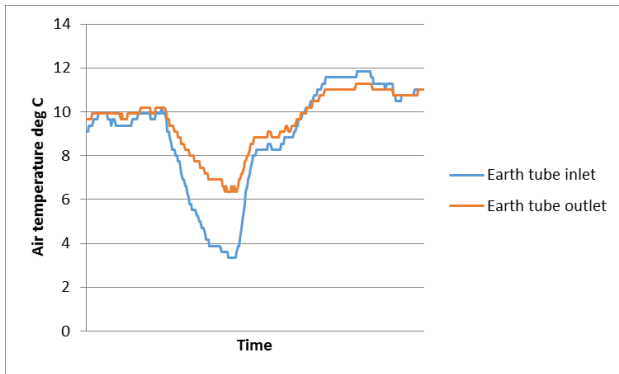

Fig 11: Temperatures over 3 days, from 4-5 January 2014

The heating and cooling effect of the earth tube can be calculated as follows.

(Mean velocity x Area = flow rate):

$$1.5\text{m/s} \times 0.28 \text{ m}^2 = 0.42 \text{ m}^3/\text{s}$$

(Density x flow rate = mass/sec. Density of air = 1.2kg/m<sup>3</sup>):

$$1.2 \times 0.42 = 0.5\text{kg/s} \text{ (Specific heat capacity of air = 1.0 kJ/kg K)}$$

If dt = 3 degrees K, then 3 x 0.5 = 1500 J/s = 1500 W of cooling (when dt = 3 degrees K).

Each DC fan has a power rating of 82W. Allowing for both intake and extract fans the total power rating is therefore 164W. However, measured power levels from the CT meters indicates a maximum power consumption by the fans of 16W and an average of 14W.

The net energy gain from the earth tube is therefore highly significant and the power

consumed by the fans negligible in comparison: 500W for each degree K raised or lowered, compared to an average of 14W of power expended.

## 6. Conclusions

Results from the earth tube temperature sensors in April and May 2013 demonstrate a strong correlation between external and internal temperatures, that swing around the assumed ground temperature of approximately 11-12 °C. In hot weather the earth tube is shown to have a damping effect, reducing the extremes.

However the cooling effect of the earth tube itself is not consistently translated into a cooling effect within the building itself. The reasons for the reduced cooling performance may be attributable to a number of factors:

- 1 The effects of the heat exchanger: in the absence of clear instructions to the building operators, or automatic controls, to switch off the extract fan in hot weather, or to adjust the dampers, the heat exchanger will be pre-heating incoming air in summer, using the outgoing warm air from the building. This is counteracting the effect of the earth tube.
- 2 Solar gains may be swamping the cooling effects of the earth tube.
- 3 Casual gains may similarly be swamping the cooling by the earth tube.

The energy used by the fans is minimal compared to the energy gained by heating and the potential for cooling. It is worth noting that the monitoring period has not covered a period of extremely cold or extremely hot weather.

### 6.1 Recommendations

1 The occuli opening vents should be made operational as soon as possible to achieve natural ventilation in summer, by venting off hot air.

2 The extract fan should either be switched off in summer, or the heat exchanger should be by-passed, to avoid the unwanted and counter-productive warming effects from the extract air.

3 Either automatic controls should be introduced to control the fans, or regular (daily) monitoring should take place by the facilities management (FM) team, to ensure that fan speeds are appropriately set for the weather conditions. A guidance note should be prepared to inform the FM team on what are appropriate fan speeds for both the intake and extract fans, under various weather conditions and use patterns.

4 Explore setting the fan to a lower speed to increase the temperature difference between the inlet air and the outlet air, to better match the temperature requirements in the building.

5 On future projects employing earth tubes it is recommended that the following are considered to improve the performance:

- a Employ a longer tube, to increase the heat exchange between air and ground
- b Locate the tube deeper underground, to obtain a more stable ground temperature.

## 7. Acknowledgments

This research was made possible with funding for the monitoring process from the UK's Technology Strategy Board under its Building Performance Evaluation programme. Alistair Gould and colleagues at the Bay Trust, who commissioned, own and run the Pines Calyx, provided access to the building, and essential information, as well as playing a key role in the

Building Performance Evaluation process. Paul Mallion of Conker Conservation Limited, who undertook the detailed design of the building and administered its construction, was invaluable in answering questions about the building's design and its construction. Anne Walker of Conservation Engineering has provided information on the mechanical systems employed in the building, including the diagram in figure 5.

## 8. References

- CIBSE (Chartered Institution of Building Services Engineers). (2005). Sustainable low energy cooling: an overview CIBSE Knowledge Series: KS3.
- De Paepe, M & Janssens, A. (2003). Thermo-hydraulic design of earth-air heat exchangers. *Energy and Buildings* 35 (2003). 389-397.
- Met Office. Southern England: climate. [www.metoffice.gov.uk/climate/uk/regional-climate/so](http://www.metoffice.gov.uk/climate/uk/regional-climate/so) [downloaded 6 February 2015]