

**THE ARCHAEOLOGICAL AUTHORITY
OF THE BAYEUX TAPESTRY**

MICHAEL JOHN LEWIS

APPENDIX

Submitted for the Degree of Doctor of Philosophy in History

University of Kent at Canterbury

September 2003

Corrections: April 2004 (following *viva*)



F185477

ATTRIBUTES CITED IN MANUSCRIPT ILLUMINATIONS

Buildings and Architecture

Arcading

Anglo-Saxon and Romanesque: Hildesheim, S-GC, 1, p.48, Cambridge, PC, 120, f.2v, f.3, f.5v, f.11, TCC, R. 17. 1, f.111 and BodL, Bodley 494, f.162v. TCC, B. 16. 3, f.1v, BL, Harley 603, f.66v, BL, Cotton Claudius B. iv, f.32, BL, Cotton Caligula A. xv, f.122v, PML, M 736, p.15, Cambridge, S-JC, A. 8. f.103v, BL, Royal 1 C. vii, f.58, BL, Lansdowne 383, f.14, CUL, Dd. 6. 6, f.2v, BodL, Laud, Misc. 469, f.7v, Dublin, CBL, 22, f.108, PML M 724v, PML, M 521 v and r, London, V&A, 661v, TCC, R. 17. 1 f.283v, f.285 and Copenhagen, RL, Thott 143 2°, f.11.

Continental: BNF, nouv. acq. lat. 1390, f.1v, f.5, BNF, lat. 254, f.46v, BNF, lat. 5296A, f.35, Parma, BP. Pal. 1650, f.4, f.9v, Verdun, BM, 8, f.1v, BNF, lat. 8, f.41, f.82, BNF, lat. 9438, f.46, Gent, CB-R, 1125 (92), f.13, Paris, BMaz, 1, f.85, BNF, lat. 2060, f.1, Vendôme, BM, 193, f.2v, Sées, BÉ, 5, *St. John*, BodL, Barlow 40, f.1, Santiago de Compostela, AC, *Liber Sancti Jacobi*, f.162v, Douai, BM, 250, f.2v, Strasbourg, GS, 37, f.2, f.4, Avranches, BM, 210, Valenciennes, BM, 500, f.55, BNF, lat. 16730, f.113, BNF, lat. 14516, f.240, f.240v, f.248, Valenciennes, BM, 501, f.30v, Wolfenbüttel, HAB, Cod. Guelf. 1 Gud. lat, f.9v, PML, M 44, f.4, Douai, BM, 340, f.39v, Hague, KB, 76 F 13, f.1v, f.20, BL, Cotton Caligula A. vii, f.5, Paris, BS-G, 1042, f.1v, Heiligenkreuz, Cod. 226, f.129v, Paris, BS-G, 9, f.111, BNF, lat. 17716, f.23, f.91 and BL, Add. 42497r.

Arched doorways and windows

Anglo-Saxon and Romanesque: BodL, Rawlinson B. 484, f.85, BL, Add. 40618, f.22v, f.49v, BL, Add. 49598, f.118v, BNF, lat. 6401, f.158v, Boulogne, BM, 11, f.55v, PML, M 869, f.17v, f.83v, BodL, Junius 11, p.57, p.84, p.87, BL, Harley 603, f.12, f.54v, BL, Royal 15 A. xvi, f.84, BL, Stowe 944, f.7, BL, Cotton Tiberius C. vi, f.11, BL, Cotton Caligula A. xv, f.122v, Florence, BM-L, Plut. XII. 17, f.2v, Oxford, UC, 165, p.45, p.26, PML, M 736, p.15, Cambridge, PC, 120, f.1, f.2v, f.4v, f.5v, f.6, f.6v, f.11, BL, Royal 1 C. vii, f.58, BL, Lansdowne 383, f.15v, CUL, Dd. 6. 6, f.2v, BodL, Auct. F. 6. 5, f.1v, TCD, 53, f.7v, BodL, Laud, Misc. 469, f.7v, Dublin, CBL, 22, f.108, PML, M 724v, BL, Add. 37472 v and r, PML, M 521 v and r, London, V&A, 661 v and r, TCC, R. 17. 1, f.9, f.283v, f.285, London, LP, 3, f.130, BodL, Auct. F. 2. 13, f.4v, BodL, Auct. D. 2. 6, f.166v, f.169, BodL, Auct. D. 1. 13, f.1, Winchester, CL, 17, f.343, f.350, PML, M 619v and r, BodL, Bodley 494, f.156, f.162 and Copenhagen, RL, Thott 143 2°, f.11.

Continental: Tours, BM, 1018, f.11, f.15, f.18, BNF, lat. 254, f.10, f.46v, BNF, lat. 5296A, f.35, BNF, nouv. acq. lat. 1390, f.1v, f.5, Parma, BP. Pal. 1650, f.4, f.9v, f.22, f.39, f.102v, BNF, lat. 8, f.41, f.82, BNF, lat. 9438, f.20v, f.24, f.46v, Quentin, CL, 1, p.9, BNF, lat. 17767, f.11v, Dijon, BM, 14, f.13v, f.165v, Tours, BM, 924, f.1, Gent, CB-R, 1125 (92) f.13, f.168, BNF, lat. 2060, f.1, Vendôme, BM, 193, f.2v, Cambrai, M, 234, f.2, Dijon, BM, 130, f.104, Sées, BÉ, 5, f.10v, f.36v, Amiens, BM, 143, f.107v, BodL, Barlow 40, f.1, BNF, lat. 116, f.65v, Santiago de Compostela, AC, *Liber Sancti Jacobi*, f.162, f.162v, Autun, BM, 132, f.9v, f.10, Lille, BM, 33, f.Mv, f.31, Boulogne, BM, 53, f.73, BAV, Pal. Lat. 497, f.58v, Strasbourg, GS, 37, f.4, Avranches, BM, 210, f.4v, f.19v, Valenciennes, BM, 500, f.55, f.64v, BNF, lat. 16730, f.113, f.262v, BNF, lat. 14516, f.240, f.240v, f.248, Valenciennes, BM, 501, f.30v, Saint-Omer, B, 12, Vol. II, f.1v, Wolfenbüttel, HAB, Cod. Guelf. 1 Gud. lat, f.9v, Valenciennes, BM, 501, f.5v, BNF, lat. 16745, f.171, f.197v, Cambrai, M, 967, f.2, BL, Cotton Caligula A. vii, f.5, f.8, Paris, BS-G, 1042, f.1v, The Hague, KB, 76 F 13, f.1v, f.20, f.28v, Paris, BÉB-A, 38, Heiligenkreuz, Cod. 226, f.129v, Paris, BS-G, 9, f.111, BNF, lat. 17716, f.91, The Hague, KB, 76 F 5, f.1, and BL, Add. 42497 r and v.

Battlements

Anglo-Saxon and Romanesque: BodL, Junius 11, p.11, BL, Harley 603, f.13v, x/xi, f.66v, BL, Cotton Caligula A. xiv, BodL, Auct. D. 2. 6, f.166v, PML, M 724 r and v, BL, Add. 37472r, London, V&A,

661v, Cambridge, PC, 120, f.2v, f.4v, PML, M 521v, DUL, Cosin V.III.1, f.22v, Winchester, CL, 17, f.331v, f.350v, PML, M 619v, BodL, Bodley 494, f.156, f.162 and GUL, Hunter U. 3. 2, f.15v.

Continental: Tours, BM, 1018, f.11, Quentin, CL, 1, p.11, Dijon, BM, 14, f.13v, Tours, BM, 924, f.13v, Gent, CB-R, 1125 (92), f.168, Berlin, SM-D-K, 78 A 4, f.1, Sées, BÉ, 5, f.36v, BodL, Barlow 40, f.1, Santiago de Compostela, AC, *Liber Sancti Jacobi*, f.162v, BL, Cotton Caligula, A. vii, f.5, f.8v, The Hague, KB, 76 F 13, f.20, f.28v, BNF, lat. 14516, f.240, f.240v, f.248, BNF, lat. 16745, f.197v, Heiligenkreuz, Cod. 226, f.129v, Paris, BS-G, 9, f.111, The Hague, KB, 76 F 5, f.1 and BL, Add. 42497v.

Battlements associated with ecclesiastical structures

Anglo-Saxon and Romanesque: BodL, Auct F. 6. 5, f.1v, BodL, Auct. D. 2. 6, f.169 and TCC, R. 17. 1, f.285.

Continental: Gent, CB-R, 1125 (92), f.13, Boulogne, BM, 53, f.73 and Avranches, BM, 210, f.4v.

Columns that support open planned structures

Anglo-Saxon and Romanesque: BodL, Junius 11, p.9, p.10, p.13, p.41, p.45, p.47, p.54, p.56, p.57, p.58, p.59, p.62, p.63, p.84, CCCC, 183, f.1v, BodL, Rawlinson B. 484, f.85, PML, M 869, f.17v, f.83v, BL, Harley 603, f.15, f.66v, BL, Cotton Claudius B. iv, f.32, BodL, Lat. lit. F. 5, f.21v, f.30v, BL, Cotton Tiberius C. vi, f.11, CCCC, 389, f.1v, BL, Cotton Caligula A. xv, f.122v, DCL, Hunter 100, f.119, PML, M 736, p.15, Cambridge, PC, 120, f.2v, f.11, BL, Royal 1 C. vii, f.58, BodL, Auct. F. 6. 5, f.1v, TCD, 53, f.7v, BodL, Laud, Misc. 469, f.7v, Dublin, CBL, 22, f.108, PML, M 521 v and r, London, V&A, 661v, TCC, R. 17. 1, f.92, f.283v, f.285, BL, Harley 603, f.29, London, LP, 3, f.130, BodL, D. 2. 6, f.166v, f.169, Winchester, CL, 17, f.350v, PML, M 619 v and r, BodL, Bodley 494, f.156, f.162v, Cambridge, S-JC, H. 6, f.iii, GUL, Hunter U. 3. 2, f.12, f.15v, Copenhagen, RL, Thott 143 2°, f.11 and BL, Cotton Claudius, B. ii, f.341.

Continental: Boulogne, BM, 11, f.55v, Tours, BM, 1018, f.11, Ameins, BM, Lescalopier 2, f.11⁵v, f.11⁶, BNF, nouv. aqu. lat. 1390, f.1v, f.2, f.5, BNF, lat. 254, f.10, f.46v, BNF, lat. 5296A, f.35, Parma, BP, Pal. 1650, f.4, f.9v, f.102v, Tours, BM, 291, f.132, BNF, lat. 8, f.82, BNF, lat. 9438, f.46v, Vendôme, BM, 193, f.2v, BNF, lat. 12054, f.79, Quentin, CL, 1, p.6, p.11, Gent, CB-R, 1125 (92) f.168, Tours, BM, 924, f.13v, BAV, Vat. Lat. 3305, f.8v, Paris, BMaz, 1, f.85, BNF, lat. 2060, f.1, BNF, lat. 15307, f.1v, BNF, lat. 17767, f.11v, Valenciennes, BM, 75, f.63v, Sées, BÉ, 5, f.10v, f.36v, Berlin, SM-D-K, 78 A 4, f.1, BodL, Barlow 40, f.1, Santiago de Compostela, AC, *Libre Sancti Jacobi*, f.162, Autun, BM, 132, f.9v, f.10, Lille, BM, 33, f.31, f.B, f.Mv, Boulogne, BM, 53, f.73, Strasbourg, GS, 37, f.2, f.4, Avranches, BM, 210, f.19v, Valenciennes, BM, 501, f.30v, Valenciennes, BM, 501, f.5v, PML, M 44, f.4, BL, Cotton Caligula A. vii, f.5, f.8v, The Hague, KB, 76 F 13, f.1v, f.28v, BNF, lat. 16745, f.171, Cambrai, M, 967, f.2, Paris, BS-G, 1042, f.1v, Paris, BÉB-A, 38, Heiligenkreuz, Cod. 226, f.129v, BNF, lat. 17716, f.23, f.91 and BL, Add. 42497r.

Crosses

Anglo-Saxon and Romanesque: Florence, BM-L, Plut. XII. 17, f.2v, BodL, Laud, Misc. 469, f.7v, TCC, R. 17. 1, f.9, f.285, CCCC, 183, f.1v, Oxford, UC, 165, p.45, BodL, Auct F. 6. 5, f.1v, BL, Add. 37472 (I) v, PML, M 521r, BodL, Auct D. 2. 6, f.169 and PML, M 619r.

Continental: Tours, BM, 291, f.132, Gent, CB-R, 1125 (92), f.168, Dijon, BM, 130, f.104, Boulogne, BM, 53, f.73, Strasbourg, GS, 37, f.2, Avranches, BM, 210, f.4v, Valenciennes, BM, 501, f.5v, Heiligenkreuz, Cod. 226, f.129v, BNF, lat. 17716, f.91 and The Hague, KB, 76 F 5, f.1.

Domed roofs

Anglo-Saxon and Romanesque: PML, M 869, f.83v, BL, Add. 49598, f.118v, BL, Harley 603, f.2, f.13v, f.15, f.29, f.66v, BodL, Junius 11, p.11, p.87, BL, Royal 15 A. xvi, f.84, BL, Harley 76, f.10, CUL, Ff. I. 23, f.4v, BL, Cotton Claudius B. iv, f.32, BL, Cotton Caligula A. xv, f.122v, Oxford, WC, A. 10. 22, f.104v, Oxford, UC, 165, p.45, PML, M 736, p.15, Florence, BM-L, Plut. XII, 17, f.2v, BodL, Laud, Misc. 469, f.7v, PML, M 736, p.15, Cambridge, PC, 120, f.2v, BL, Royal 1, C. vii, f.58, BL, Lansdowne 383, f.14, CUL, Dd. 6. 6, f.2v, TCD, 53, f.7v, BodL, Laud, Misc. 469, f.7v, PML, M 724v, BL, Add. 37472r, PML, M 521 v and r, BodL, Auct. D. 2. 6, f.169, BodL, Auct. D. 1. 13, f.1, Winchester CL, 17, f.5, f.331, f.342, f.350, TCC, R. 17. 1, f.92, f.283v, f.285, Copenhagen, RL, Thott 143 2°, f.11, f.69v, PML, M 619 v and r and Cambridge, S-JC, H. 6, f.iii.

Continental: Tours, BM, 1018, f.11, Amiens, BM, Lescalopier 2, f.11⁵, f.11⁶, BNF, nouv. acq. lat. 1390, f.1v, f.2, f.5, BNF, lat. 5296A, f.35, Parma, BP, Pal. 1650, f.4, f.9v, f.22, f.39, f.102v, Tours, BM, 291, f.132, BNF, lat. 8, f.41, f.82, BNF, lat. 9438, f.46v, BNF, lat. 12054, f.79, Quentin, CL, 1, p.6, p.9, p.11, Bergues, BC, 19, f.13v, BNF, lat. 17767, Paris, BMaz, 1, f.85, Gent, CB-R, 1125 (92), f.13, Sées, BÉ, 5, f.10v, Dijon, BM, 130, f.104, BodL, Barlow 40, f.1, Santiago de Compostela, AC, *Liber Sancti Jacobi*, f.162, f.162v, BNF, lat. 796, f.235v, Autun, BM, 132, f.9v, f.10, Lille, BM, 33, f.Mv, f.N, f.31, Boulogne, BM, 53, f.73, Boulogne, BM, 2, f.211, Avranches, BM, 210, f.4v, BL, Cotton Caligula, A. vii, f.5, Valenciennes, BM, 500, f.55, The Hague, KB, 76 F 13, f.1v, f.20, Valenciennes, BM, 501, f.30v, Cambrai, M, 967, f.2, Paris, BS-G, 1042, f.1v, BNF, lat. 17716, f.23, The Hague, KB, 76 F 5, f.1 and BL, Add. 42497r.

Mid-level pitched scaled roofs

Anglo-Saxon and Romanesque: CCCC, 183, f.1v, BodL, Rawlinson B. 484, f.85, Boulogne, BM, 11, f.55v, PML, M 869, f.17v, f.83v, Los Angeles, GM, MS 9, BL, Harley 603, f.13v, BL, Royal 15, A. xvi, f.84, BL, Cotton Claudius, B. iv, f.32, BL, Cotton Caligula A. xv, f.122v, Oxford, UC, 165, p.26, Hildesheim, S-GC, 1, p.55, TCC, R. 17. 1, f.111, f.285, BodL, Auct. F. 2. 13, f.4v, BodL, Auct. D. 2. 6, Winchester, CL, 17, f.350v and PML, M 619r.

Continental: BNF, lat. 8, Vol. I, f.82, Dijon, BM, 130, f.104 and Valenciennes, BM, 500, f.55.

Pointed roofs

Anglo-Saxon and Romanesque: BL, Add. 49598, f.118v, BNF, lat. 6401, f.158v, Boulogne, BM, 11, f.55v, PML, M 869, f.17v, Los Angeles, GM, MS 9, BL, Harley 603, f.2, f.66v, BL, Stowe 944, f.7, BL, Harley 76, f.10, CUL, Ff. I. 23, f.4v, BL, Cotton Claudius B. iv, f.32, CCCC, 389, f.1v, Florence, BM-L, Plut. XII. 17, f.2v, Oxford, UC, 165, p.45, Hildesheim, S-GC, 1, p.55, Cambridge, PC, 120, f.1, f.3, f.2v, f.5v, f.6, f.6v, f.11, BL, Royal 1 C. vii, f.58, BodL, Auct. F. 6. 5, f.1v, TCD, 53, f.7v, BodL, Laud, Misc. 469, f.7v, Dublin, CBL, 2, f.108, BL, Add. 37472v, London, V&A, 661 v and r, TCC, R. 17. 1, f.9, f.285, London, LP, 3, f.130, BodL, Auct. F. 2. 13, BodL, Auct. D. 2. 6, f.166v, f.169, DUL, Cosin V.III.1, f.22v, Winchester, CL, 17, f.331v, f.342, f.350v, PML, M 619r, GUL, Hunter U. 3. 2, f.12, f.15v and BL, Cotton Claudius B. ii, f.341.

Continental: BNF, lat. 254, f.10, f.46v, Tours, BM, 291, f.132, BNF, lat. 8, f.41, Quentin, CL, 1, p.6, Bergues, BC, 19, f.3v, Tours, BM, 924, f.11, BAV, Vat. Lat. 3305, f.9v, f.11v, Paris, BMaz, 1, f.85, BNF, lat. 2060, Gent, CB-R, 1125 (92), f.13, f.168, Berlin, SM-D-K, 78 A 4, f.1, Sées, BÉ, 5, f.36v, BodL, Barlow 40, f.1, Boulogne, BM, 53, f.73, Strasbourg, GS, 37, f.2, Avranches, BM, 210, f.4v, f.19v, Valenciennes, BM, 501, f.30v, Wolfenbüttel, HAB, Cod. Guelf. 1 Gud. lat, f.9v, The Hague, KB, 76 F 13, f.20, Paris, BÉB-A, 38, BNF, lat. 16730, f.113, Paris, BS-G, 1042, f.1v, Paris, BS-G, 9, f.111 and BNF, lat. 17716, f.91.

Rectangular buildings with pitched roofs

Anglo-Saxon and Romanesque: BL, Add. 49598, f.118v, BodL, Junius 11, p.87, BL, Cotton Claudius B. iv, f.36, BL, Royal 15, A. xvi, f.84, BL, Cotton Caligula A. xiv, CUL, Dd. 6. 6, f.2v, BodL, Auct. F. 2. 13, f.4v, f.47, BodL, Auct. D. 2. 6, f.169 and PML, M 619 v and r.

Continental: Tours, BM, 1018, f.15, BNF, lat. 254, f.46v, Dijon, BM, 14, f.165v, Vendôme, BM, 193, f.2v, Avranches, BM, 210, f.19v, BNF, lat. 16730, f.262v and The Hague, KB, 76 F 13, f.1v, f.20, f.28v.

Scaled roofing

Anglo-Saxon and Romanesque: CCCC, 183, f.1v, BodL, Rawlinson B. 484, f.85, TCC, B. 16. 3, f.1v, PML, M 869, f.17v, f.83v, BL, Add. 49598, f.118v, Boulogne, BM, 11, f.55v, f.107, BodL, Junius 11, p.57, p.84, p.87, BL, Harley 603, f.12, f.13v, f.15, f.54v, f.66v, BL, Royal 14 A. xvi, f.84, BL, Harley 76, f.10, BL, Cotton Claudius B. iv, f.32, BL, Stowe 944, f.7, BodL, Lat. lit. F. 5, f.30v, BL, Royal 15 A. xvi, f.84, BL, Cotton Caligula A. xiv, f.22, BL, Cotton Tiberius C. vi, f.11, CCCC, 389, f.1v, Oxford, UC, 165, p.26, Hidesheim, S-GC, 1, p.55, PML, M 736, p.15, Cambridge, PC, 120, f.2v, f.11, BL, Royal 1, C. vii, f.58, PML, M 724v, BL, Add. 37472 v and r, PML, M 521 v and r, TCC, R. 17. 1, f.9, f.92, f.111, f.285, f.288v, BodL, Auct. F. 2. 13, f.16 and PML, M 619 v and r.

Continental: BNF, lat. 5296A, f.35, Tours, BM, 291, f.132, BNF, lat. 9438, f.46, Quentin, CL, 1, p.11, Dijon, BM, 14, f.165v, Vendôme, BM, 193, f.2v, Paris, BMaz, 1, f.85, BodL, Barlow 40, f.1, Lille, BM, 33, f.Mv, f.N, Avranches, BM, 210, f.19v, BNF, lat. 16730, f.262v, Wolfenbüttel, HAB, Cod. Guelf. 1 Gud. lat, f.9v, PML, M 44, f.10v, The Hague, KB, 76 F 13, f.1v, BNF, lat. 16745, f.171, Paris, BÉB-A, 38, BNF, lat. 17716, f.91 and BL, Add. 42497r.

Towers that support open planned structures

Anglo-Saxon and Romanesque: BodL, Junius 11, p.3, p.17, p.51, p.59, BL, Add. 49598, f.118v, PML, M 869, f.83v, BL, Harley 603, f.13v, BodL, Auct. D. 2. 6, f.166v and Winchester, CL, 17, f.331v, f.350v.

Continental: Boulogne, BM, 11, f.55v, Tours, BM, 1018, f.11, f.15, f.18, BNF, lat. 116, f.65v, BAV, Pal. Lat. 497, f.58v, Avranches, BM, 210, f.19v and BNF, lat. 17716, f.91.

Two storey houses

Anglo-Saxon and Romanesque: BodL, Junius 11, p.3, p.51, Cambridge, PC, 120, f.2v, f.11, TCC, R. 17. 1, f.111, f.283v, BodL, Auct. F. 2. 13, BodL, Bodley 494, f.162v and PML, M 619r.

Continental: BNF, lat. 9438, f.24, Tours, BM, 924, f.1, BNF, lat. 14516, Valenciennes, BM, 501, f.5v and Paris, BÉB-A, 38.

Arms and Armour

Axes

Anglo-Saxon and Romanesque: BL, Cotton Cleopatra C. viii, f.27v, BodL, Junius 11, p.81, BL, Cotton Julius A. vi, f.5v, BL, Harley 603, f.4r, BL, Cotton Vitellius C. xii, f.121, BL, Harley 624, f.108v, xii¹ (Canterbury, Christ Church), Cambridge, PC, 120, f.1, PML, M 736, p.24, p.26, Cambridge, S-JC, A. 8, f.39v, PML, M 521r, BodL, Auct. D. 2. 6, f.6v, Winchester, CL, 17, f.342, BodL, Auct. E. inf. 1, f.264v, PML, M 81, f.12v and BodL, Gough liturg. 2, f.17.

Continental: Avranches BM, 72, f.151, Dijon, BM, 14, f.13, f.13v, Dijon, BM, 173, f.41, Paris, BÉB-A, 12 and BNF, lat. 11534, f.6.

Archers

Anglo-Saxon and Romanesque: BL, Cotton Cleopatra C. viii. f.23, BL, Harley 603, f.4r, f.14v, f.15r, BL, Cotton Galba A. xviii, f.14r, BAV, Reg. Lat. 12, f.24v, f.109v, Cambridge, S-JC, B. 20, f.2v, BL, Cotton Tiberius C. 1, f.25v, TCC, O. 2. 51, f.100 and BodL, Laud, Misc. 469, f.7v.

Continental: Amiens, BM, 18, f.95, Boulogne, BM, 11, f.3v, f.7v, Bordeaux, BM, 1, f.207, Dijon, BM, 14, f.13, f.13v and BNF, lat. 1626, f.56v.

Conical helmets (segmented and non-segmented)

Anglo-Saxon and Romanesque: BL, Cotton Tiberius C. vi, f.8v, f.9, BL, Cotton Tiberius B. v, f.85, BL, Add. 24199, f.17, BL, Harley 603, f.73v, DCL, Hunter 100, f.119v, Cambridge, PC, 120, f.2v, f.3v, TCD, 53, f.151, PML, M 521v, BL, Royal 6, C. vi, f.79v, BL, Arundel 91, f.188, Oxford, UC, 165, p.8, Hildesheim, S-GC, 1, p.48, TCC, R. 3. 30, f.1, PML, M 724r, Oxford, CCC, 2, f.2, London, V&A, 661v, Madrid, BN, Vit 23-8, f.15, f.81v and DCL, A. II. 1, Vol. III, f.131v.

Continental: Stuttgart, WLB, bibl. 2° 23, f.49, Nürnberg, GNM, 156.142/KG1138, f. 18v, BNF, lat. 8, f.82, BNF, lat. 15307, f.1v, Dijon, BM, 14, f.13, f.13v, Berlin, SM-D-K, 78 A 4, f.66v, BAV, Lat. 1269, Dijon, BM, 641, f.40v, Paris, BCD, 2, f.164, Santiago de Compostela, AC, *Libre Sancti Jacobi*, f.162v, BNF, lat. 16730, f.262v, Lyons, BM, 410, f.41v and Paris, BS-G, 9, f.111.

Conical helmets with nasal guards

Romanesque: BL, Royal 6 C. vi, f.79v, Cambridge, PC, 120, f.2v, PML, M 724r, London, V&A, 661v, Santiago de Compostela, AC, *Libre Sancti Jacobi*, f.162v, Winchester, CL, 17, f.69, f.250v, PML, M 619v, DCL, A. II. 1, Vol. III, f.131v and BL, Cotton Claudius B. ii, f.341.

Continental: Dijon, BM, 14, f.13, f.13v, Lyons, BM, 410 and Paris, BS-G, 9, f.111.

Disc-shaped pommels

Anglo-Saxon and Romanesque: BL, Cotton Cleopatra C. viii, f.10r, BL, Cotton Claudius B. iv, f.24v, TCC, B. 5. 2, f.70, Lincoln, CL, A. 1. 2, f.70v, BL, Arundel 91, f.179, Florence, BM-L, Plut. XII. 17, f.1v, BL, Cotton Titus D. xvi, f.14, PML, M 736, p.13, Cambridge, PC, 120, f.3v, DCL, A. 1. 10, f.170, PML, M 521r, PML, M 724r, BL, Harley 603, f.29, BodL, Auct. D. 2. 6, f.166v, CCCC, 3-4, f.139v, Winchester, CL, 17, f.331v and BL, Add. 11283, f.10v.

Continental: Nürnberg, GNM, 156.142/KG1138, f.18v, Tours, BM, 1018, f.9v, BNF, lat. 8, f.82, Dijon, BM, 14, f.13, Dijon, BM, 168, f.4v, 169, f.88v, Rouen, BM, A. 5 (7), f.148, Saint-Omer, B, 34, f.1v, Berlin, SM-D-K, 78 A 4, f.66v, Santiago de Compostela, AC, *Liber Sancti Jacob*, f.162v, Clermont-Ferrand, BM, 1, f.106, Munich, BSB, Clm. 28565, f.10, Boulogne, BM, 2, f.22, f.146, BNF, lat. 16730, f.262v, Cambrai, M 967, f.10, Lille, ADN, 10 H 323, p.104, BL, Cotton Caligula A. vii, f.7, BNF, lat. 11534, f.6, Lyons, BM, 410, f.41v, Wolfenbüttel, HAB, Cod. Guelf. 1 Gud. lat, f.9v, f.10, f.88, The Hague, KB, 76 F 13, f.29, Moulins, BM, 1, f.93, Amiens, BM, 19, f.8 and The Hague, KB, 76 F 5, f.2v.

Kite-shields with bosses

English Romanesque: BL, Arundel 91, f.188, Cambridge, S-JC, B. 20, f.2v, BL, Harley 603, f.29v, PML, M 724r, TCC, R. 17. 1, f.9, Winchester, CL, 17, f.350v, PML, M 619v and DCL, A. II. 1, Vol. III, f.131v.

Continental Romanesque: Dijon, BM, 14, f.13, f.13v.

Kite-shields without bosses

English Romanesque: CCCC, 3-4, f.117v, Winchester, CL, 17, f.350v and PML, M 619v.

Continental Romanesque: BNF, lat. 8, f.82, square top shield - Paris, BCD, 2, f.164, square top kite-shield - Lille, ADN, 10 H 323, p.104, square top kite-shield – The Hague, Mun, 19, f.8 and The Hague, KB, 76 F 5, f.1.

Phygrian caps

Anglo-Saxon and Romanesque: Salisbury, CL, 150, f.5, Rouen, BM, Y. 6 (8), f.36v, BodL, Douce 296, f.40v, BL, Arundel 60, f.13, Cambridge, S-JC, A. 8, f.39v, Oxford, CCC, 157, p.383, BodL, Auct. F. 2. 13, f.47 and Winchester, CL, 17, f.350v.

Round-shields with convex boards

Anglo-Saxon and Romanesque: BL, Add. 49598, f.51v, CCCC, 23, f.2, BL, Cotton Cleopatra C. viii, f.4v, BL, Add. 24199, f.17, BodL, Junius 11, p.57, BL, Harley 603, f.2, BL, Cotton Julius A. vi, f.4v, BL, Cotton Caligula A. xiv, f.22, BL, Cotton Tiberius C. vi, f.8v, f.9, f.16, BAV, Reg. Lat. 12, f.36r, f.27v, BodL, Douce 296, f.40v, BNF, lat. 8824, f.4r, Florence, BM-L, Plut. XII, 17, f.1v, BL, Harley 624, f.108v, BL, Harley 603, f.2, TCC, R. 17. 1, f.20, f.92, Madrid, BN, Vit 23-8, f.81v, Winchester, CL, 17, f.350v and BL, Cotton Claudius B. ii, f.341.

Continental: Berlin, SM-D-K, 78 A 4, f.66v, Dijon, BM, 641, f.40v, Boulogne, BM, 53, f.73, Boulogne, BM, 2, f.22, Lyon, BM, 410, f.41v, Moulins, BM, 1, f.93, Paris, BS-G, 8, f.141v and Paris, BS-G, 9, f.194.

Tea-cosy pommels

Anglo-Saxon: BL, Cotton Cleopatra C. viii, f.8r, f.11r, f.11v, f.12r, f.16v, f.18v, BL, Harley 603, f.72v, BAV, Reg. Lat. 12, f.32r, f.87v and BL, Cotton Tiberius C. vi, f.8v, f.9.

Three-lobed pommels

Anglo-Saxon: BL, Cotton Cleopatra C. viii, f.4r, f.16v, BodL, Junius 11, p.46, p.57, BL, Stowe 944, f.6, BAV, Reg. Lat. 12, f.87v, BL, Cotton Claudius B. iv, f.38 and BL, Cotton Tiberius B. v, f.85v.

Trousered hauberks

Anglo-Saxon and Romanesque: BL, Cotton Claudius B. iv, f.24v, BL, Harley 603, f. 73v and BL, Arundel 91, f.188.

Continental: Dijon, BM, 14, f.13 and The Hague, KB, 76 F5, f.1.

Winged spears

Anglo-Saxon and Romanesque: BAV, Reg. Lat. 12, f.36r, BL, Cotton Cleopatra C. viii, f.4v-5r, BL, Add. 49598, f.51v, CCCC, 23, f.2, BL, Add. 24199, f.17, BodL, Junius 11, p.3, BL, Cotton Julius A. vi, f.4v, BL, Harley 603, f.1v-4r, BL, Cotton Claudius B. iv, f.25, BL, Cotton Tiberius C. vi, f.8v, f.9, f.16, PML, M 521v, TCC, R. 17. 1, f.20, f.92 and CCCC, 22, f.162.

Continental: Dijon, BM, 14, f.13, f.13v, Dijon, BM, 168, f.4v and Dijon, BM, 641, f.40v.

Dress and Clothing

Brooches (circular)

Anglo-Saxon: CCCC, 183, f.1v, BL, Cotton Vespasian A. viii, f.2v, Boulogne, BM, 11, f.11, f.12, BL, Cotton Cleopatra C.viii, f.29, BL, Add. 24199, f.17, CCCC, 23, f.2, f.37v, BodL, Junius 11, p.57, p.58, BL, Cotton Julius A. vi, f.4v, f.5, Rouen, BM, Y. 6 (274). f.36v, BL, Cotton Claudius B. iv, f.15v, f.38, f.139v, CUL, Ff. I. 23, f.4v, BL, Cotton Tiberius B. v, f.5, f.34, f.87, BL, Cotton Tiberius C. vi, f.13, f.17v and BL, Cotton Tiberius A. iii, f.2.

Romanesque: CCCC, 391, p.24, BL, Arundel 91, f.179, Florence, BM-L, Plut. XII. 17, f.2v, Oxford, UC, 165, p.18, DCL, Hunter 100, f.119v, Hildesheim, S-GC, 1, p.48, BL, Cotton Titus D. xvi, f.34, Verdun, BM, 70, f.68v, PML, M 736, p.13, Cambridge, PC, 120, f.1, f.1v, f.2v, f.3, f.3v, f.4v, f.5v, CUL, li. 3. 12, f.61v, BL, Royal 1, C. vii, f.154v, BL, Lansdowne 383, f.15, CUL, Dd. 6. 6, f.2v, BodL, Bodley 269, f.iii, TCD, 53, f.151, Oxford, CCC, 157, p.382, p.383, CCCC, 2, f.94, f.147v, PML, M 521 v and r, London, V&A, 661r, PML, M 724 v and r, BL, Add. 37472r, BL, Harley 603, f.29, TCC, R. 17. 1, f.9, CCCC, 3, f.26, BodL, Auct. F. 2. 13, f.16, f.47, f.54v, f.85v, BodL, Auct. D. 2. 6, f.169, BodL, Auct. D. 1. 13, f.1, Winchester, CL, 17, f.190, f.200, f.331v, PML, M 619r and v, BodL, Gough liturg. 2, f.17, DCL, A. II. 9, f.130v, BodL, Laud, Misc. 752, f.146 and BL, Add. 11283, f.10v. Continental examples include are just as numerous.

Brooches (rectangular)

Anglo-Saxon: Boulogne, BM, 11, f.11 and BL, Cotton Tiberius A. iii, f.117v.

Romanesque and Continental: PML, M 619v, Amiens, BM, Lescalopier 2, f.11⁵v, BNF, nouv. acq. lat. 1390, f.1v and BNF, lat. 16746, f.7v.

Cloaked horsemen

Romanesque and Continental: PML, M 521v, BL, Add. 37472r, PML, M 724v, TCC, R. 17. 1, f.92, PML, M 619v, Copenhagen, RL, Thott, 143 2^o, f.10v, BNF, lat. 8959, f.85, The Hague, KB, 76 F 13, f.5v, Paris, BS-G, 8, f.141, Paris, BS-G, 9, f.194 and Heiligenkreuz, Cod. 226, f.129v.

Cloaks (short)

Anglo-Saxon: CCCC, 183, f.1v, BL, Cotton Vespasian A. viii, f.2v, Boulogne, BM, 11, f.11, f.12, CCCC, 23, f.37v, BL, Add. 24199, f.17, BL, Cotton Cleopatra C. viii, f.29, BodL, Junius 11, p.57, p.58, BL, Cotton Julius A. vi, f.4v, BL, Cotton Claudius B. iv, f.15v, f.38, f.139v, CUL, Ff. I. 23, f.4v, BL, Cotton Tiberius B. v, f.5, f.34, f.85v and BL, Cotton Tiberius C. vi, f.8v, f.13.

Romanesque and Continental: Oxford, UC, 165, p.18, CCCC, 2, f.94, f.147v, BodL, Auct. F. 2. 13, f.54v, Winchester, CL, 17, f.350v, BNF, lat. 5058, f.3, BNF, lat. 7211, f.134, Le Mans, BM, 227, f.13, Tours, BM, 291, f.132, Clermont-Ferrand, BM, 1, f.102 and The Hague, KB, 76 F 13, f.29.

Longer cloaks are found in DCL, Hunter 100, f.119v, PML, M 736, p.13, CUL, li. 3. 12, f.61v, BL, Harley 603, f.29v, PML, M 724r, BL, Add. 37472r, PML, M 521r, BodL, Auct. F. 2. 13, f.4v, f.16, f.47, f.85v, BodL, Digby 83, f.48v, Winchester, CL, 17, f.200v, PML, M 619r, PML, M 619v and BL, Add. 11283, f.10v.

Ecclesiastical vestments with cruciform motifs

Romanesque illuminations: Vendôme, BM, 193, f.2v, BNF, lat. 17767, f.11v, f.91, Tours, BM, 321, f.2, Dijon, BM, 641, f.4v, Santiago de Compostela, AC, *Liber Sancti Jacobi*, f.163, Strasbourg, GS, 37,

f.5, Munich, SB, Clm. 28565, f.11, Lille, ADN, 10 H 323, 27, Valenciennes, BM, 500, f.55, BNF, lat. 2287, f.1v and Valenciennes, BM, 512, f.4v.

Female clothing with decorative embellishment

Romanesque: Hemlines of dresses in BL, Royal 1, C. vii, f.58, which are decorated with small squares. Similarly, the dress of a lady in BodL, Auct. F. 6. 5, f.1v, has a decorated hemline. The dress of the lady in PML, M 619r, has a plain banded hem, as does Mary in BodL, Douce 293, f.10, and London, LP, 3, f.198. Women in Winchester CL, 17, f.331v have plain banded cuffs and necklines. Mary's dress in BodL, Gough liturg. 2, f.17, has a decorated hem with cross motifs. Mary's dress in Oxford, CCC, 157, p.77b, has braded decoration on the cuffs, neck, hemline and front. Similarly the women in BodL, Auct. F. 2. 13, f.47, f.54v, f.85v, have ornately decorated cuffs, necklines and hem, with even some (in one instance) linear decoration on the legs. Eve in GUL, Hunter U. 3. 2, f.8, has a plain neckband and braded decoration to the front of her dress. Mary's headdress in BodL, Bodley 269, f.111, has a decorated band on its lower edge.

Continental Romanesque: Mary's dress in both Troyes, BM, 894, f.113v, and Tours, BM, 193, f.70, have an embroidered hem, as do women in Strasbourg, GS, 37, f.4, f.5. Mary in both Autun, BM, 132, f.9v, and Clermont-Ferand, BM, 63, f.58, have ornately decorated cuffs. Mary's dress in both Lille, BM, 33, f.Mv, and Dijon, BM, 129, f.4v, are embellished with decorative hem and cuffs, and so is that of Gregory's mother in Valenciennes, BM, 512, f.4v. This is also true of St Leuinna in Bergues, BC, 19, f.112 and the wise (and foolish) virgins in Berlin, SM-D-K, 78 A 4, f.18, f.18v, who also have ornately decorated necklines. The sleeves of a woman in Tours, BM, 924, f.13v, is embellished with circular motifs. The Virgin's dress in Tours, BM, 193, f.98, is decorated with trefoil motifs, which is also found in Clermont-Ferrand, BM, 1, f.106, Valenciennes, BM, 501, f.30v and Strasbourg, GS, 37, f.5. The long cloak worn by Mary in Valenciennes, BM, 108, f.58v has liner motif embroidery. The dress of the female donor of The Hague, KB, 76 F 13, f.28v is decorated with linear bands of embroidered geometric motif.

Female garments with long-sleeves

Anglo-Saxon: BL, Add. 33241, f.1v and PML, M 709, f.1v.

Romanesque: Cambridge, PC, 120, f.5v, BodL, Bodley 269, f.111, Oxford, CCC, 157, p.77b, CCCC 4, f.139v, London, LP, 3, f.198, f.307, BodL, Auct. F. 2. 13, f.54v, f.85v, Winchester, CL, 17, f.331v, PML, M 619r, GUL, Hunter U. 3. 2, f.11v, Amiens, BM, Lescalopier 2, f.11ter, Tours, BM, 924, f.13v, BAV, Vat. Lat. 3305, f.8v, Dijon, BM, 14, f.165v, Reims, BM, 23, f.69v, BNF, lat. 9865, f.5v, Tours, BM, 193, f.98, Valenciennes, BM, 512, f.4v and Strasbourg, GS, 37, f.5.

Female gowns

Anglo-Saxon: BL, Cotton Vespasian A. viii, f.2v, TCC, O. 3. 7, f.1, BL, Add. 49598, f.15v, Rouen, BM, Y. 7 (369), f.21v, f.54v, Boulogne, BM, 11, f.56, CCCC, 23, f.37v, f.17v, BL, Cotton Cleopatra C. viii, f.10v, f.11, Munich, SB, Clm. 290316, f.1v, BL, Add. 24199, f.16v, London, LP, 200, f.68v, PML, M 869, f.9v, BodL, Junius 11, p.57, BodL, Bodley 577, f.1v, BL, Cotton Claudius B. iv, f.15v, f.32, f.36, CCCC, 421, p.1, PML, M 709, f.1v, BL, Stowe 944, f.6 and BL, Arundel 60, f.12v.

Romanesque: Oxford, UC, 165, p.45, DCL, Hunter 100, f.4, Hildesheim, S-GC, 1, p.48, Cambridge, PC, 120, f.5v, Cambridge, S-JC, B. 20, f.2v, BL, Royal 1, C. vii, f.58, BodL, Auct. F. 6. 5, f.1v, BodL, Bodley 269, f.111, BodL, Laud. Misc. 469, f.7v, Oxford, CCC, 157, p.77b, CCCC, 2, f.147v, PML, M 724 v and r, BL, Add. 37472r, PML, M 521v, London, V&A, 661r, TCC, R. 17. 1, f.9, CCCC, 4, f.139v, London, LP, 3, f.130, f.198, f.307, BodL, Auct. F. 2. 13, f.54v, f.85v, BodL, Auct. D. 2. 6, f.158v, BL, Cotton Nero C. iv, f.30, Winchester, CL, 17, f.331v, PML, M 619r, GUL, Hunter U. 3. 2, f.8, f.11v, Copenhagen, RL, Thott 143 2°, f.11 and BodL, Gough liturg. 2, f.17. Examples are just as numerous in continental illuminations.

Female sleeveless over-garments

Romanesque and Continental: Hildesheim, S-GC, 1, p.48, PML, M 724r, BL, Add. 37472r, London, V&A, 661r, TCC, R. 17. 1, f.92, BL, Cotton Nero C. iv, f.29, f.30, Copenhagen, RL, Thott 143 2°, f.11, Amiens, BM, Lescalopier 2, f.19⁵, Poitiers, BM, 40, f.15v, Reims, BM, 23, f.69v, Tours, BM, 193, f.70 and Clermont-Ferrand, BM, 63, f.58.

Female under-garment

Anglo-Saxon: BL, Add. 49598, f.15v, Rouen, BM, Y. 7 (369), f.21v, f.54v, PML, M 869, f.9v, BodL, Bodley 577, f.1v, BL, Stowe 944, f.6 and CCCC, 421, p.1.

Romanesque: Oxford, UC, 165, p.45, Cambridge, PC, 120, f.5v, BodL, Bodley 269, f.111, CCCC, 2, f.147v, BodL, Auct. F. 2. 13, f.85v, BodL, Auct. D. 2. 6, f.158v, BL, Cotton Nero C. iv, f.30 and GUL, Hunter U. 3. 2, f.11v. Continental examples are equally numerous.

Gowns embellished with motifs

Anglo-Saxon: BL, Arundel 60, f.12v, Boulogne, BM, 11, f.56, Florence, BM-L, Plut. XVII. 20, f.1, BL, Cotton Titus D. xxvii, f.65v, BL, Arundel 155, f.133, BL, Stowe 944, f.7, Warsaw, BN, I. 3311, f.15 and BL, Cotton Tiberius C. vi, f.17v.

Romanesque: Oxford, WC, A. 10. 22, f.22v, Florence, BM-L, Plut. XII. 17, f.2v and BodL, Laud. Misc. 469, f.7v.

Gowns embroidered with a band above the knee

Anglo-Saxon: Florence, BM-L, Plut. XVII. 20, f.1, Warsaw, BN, I. 3311, f.15, BL, Arundel 60, f.12v and BL, Cotton Tiberius C. vi, f.17v.

Romanesque and Continental: BL, Arundel 60, f.13, BNF, lat. 14782, f.52v, Cambridge, PC, 120, f.11, BL, Lansdowne 383, f.12v, Verdun, BM, 8, f.1v, Bergues, BC, 19, f.78, Reims, BM, 18, f.83v, Valenciennes, BM, 75, Arras, 721 (1027), f.38v, Verdun, BM, 43, f.75, Munich, SB, Clm. 28565, f.10, Santiago de Compostella, AC, *Liber Sancti Jacobi*, f.163 and Valenciennes, BM, 512, f.4v.

Gowns with diagonal fold

Anglo-Saxon: BL, Cotton Galba A. xviii, f.2, f.21, f.120v, BodL, Auct. F. 4. 32, f.1, Oxford, S-JC, 28, f.2, f.81v, BL, Cotton Vespasian A. viii, f.2v, TCC, O. 3. 7, f.1, BL, Add. 49598, f.15v, f.19v, f.56v, BNF, lat. 6401, f.158v, f.159, CCCC, 411, f.1v, Boulogne, BM, 11, f.12, f.55v, f.56, CCCC, 23, f.37v, BL, Cotton Cleopatra C. viii, f.10v, f.11, BL, Add. 24199, f.17, PML, M 869, f.9v, f.17v, f.83v, York Minster, CL, Add. 1, f.22v, f.60v, f.85v, Copenhagen, RL, G.K.S. 10, 2°, f.82v, BL, Royal 1, E. vi, f.30v, Los Angeles, GM, MS 9, *Christ and Apostles and Miracle of the Tribute Money*, BodL, Bodley 577, f.1, f.1v, BodL, Junius 11, p.11, p.41, p.61, p.74, p.84, p.87, BL, Harley 603, f.1, BodL, Bodley 155, f.93v, f.146v, BL, Cotton Vitellius C. iii, f.11v, f.19, TCC, B. 10. 4, f.16v, f.17v, Rouen, BM, Y. 6 (274), f.72, f.81v, f.164v, Florence, BM-L, Plut. XVII. 20, f.1, BL, Cotton Claudius, B. iv, f.2, f.139v, BL, Add. 34890, f.10v, Hanover, KM, WM XXI^a 36, f.65v, f.147v, Cambridge, PC, 301, f.10v, f.70v, BL, Cotton Titus D. xxvi, f.19v, f.65v, f.75v, TCC, B. 15. 34, f.1, Besançon, BM, 14, f.58v, CUL, Ff. I. 23, f.171, BodL, Douce 296, f.40, BAV, Reg. Lat. 12, f.36, f.73, BL, Stowe 944, f.6, f.6v, f.7, BodL, Lat. lit. F. 5, f.13v, f.21v, f.30v, Warsaw, BN, I. 3311, f.55, f.83v, PML, M 709, f.1v, f.2v, PML, M 708, f.2v, BL, Cotton Tiberius C. iv, f.18v, BL, Arundel 60, f.12v, CCCC, 422, p.52 and Reims, BM, 9, f.23.

Hats

Romanesque: Florence, BM-L, Plut. XII. 17, f.1v, Hidesheim, S-GC, 1, p.48, BL, Cotton Titus D. xvi, f.34, Cambridge, PC, 120, f.2v, f.3, f.5v, CCCC, 2, f.94, London, V&A, 661v, BL, Add. 37472r, Tours, BM, 924, f.13v, BNF, lat. 15307, f.1v, Dijon, BM, 2, f.235v and PML, M 44, f.10v.

Kerchiefs that are rounded

Anglo-Saxon: CCCC, 23, f.37v, f.17v, BL, Cotton Cleopatra C. viii, f.10v, f.11, BL, Add. 24199, f.16v, Rouen, BM, Y. 7 (369), f.21v, f.54v, BodL, Bodley 577, f.1v, BL, Cotton Claudius B. iv, f.15v, f.32, f.36 and PML, M 709, f.1v.

Romanesque: Oxford, UC, 165, p.45, Hildesheim, S-GC, 1, p.48, BodL, Laud. Misc. 469, f.7v, Oxford, CCC, 157, p.77b, CCCC, 2, f.147v, PML, M 724 v and r, BL, Add. 37472r, PML, M521 v and r, London, V&A, 661r, London, LP, 3, f.130, f.198, BodL, Auct. F. 2. 13, f.54v, f.85v, BodL, Auct. D. 2. 6, f.158v, BL, Cotton Nero C. iv, f.30, PML, M 619r, GUL, Hunter U. 3. 2, f.8, f.11v, Copenhagen, RL, Thott 143 2°, f.11 and BodL, Gough liturg. 2, f.17.

Leg-bands

Anglo-Saxon: BodL, Tanner 10, f.115v, BL, Cotton Vespasian A. viii, f.2v, Boulogne, BM, 11, f.12, BL, Add. 24199, f.17, BodL, Junius 11, p.58, p.74, p.84, p.87, Rouen, BM, Y. 6 (274), f.36v, BL, Cotton Julius A. vi, f.4v, f.5, BL, Stowe 944, f.6, f.6v, f.7 and BL, Cotton Tiberius C. vi, f.8v, f.9, f.13.

Romanesque: TCC, B. 5. 26, f.1, Lincoln, CL, A. 3. 17, f.8v, Florence, BM-L, Plut. XII. 17, f.1v, Hildesheim, S-GC, 1, p.48, PML, M 736, p.13, p.26, Cambridge, PC, 120, f.2v, CUL, Ii. 3. 12, f.61v, TCC, R. 17. 1, f.111, BodL, Auct. E. inf. 1, f.264v, Winchester, CL, 17, f.200v and CCCC, 22, f.162. Continental Romanesque examples are also numerous.

Phrygian caps

Anglo-Saxon: Rouen, BM, Y. 6 (274), f.36v, BodL, Douce 296, f.40v and BL, Cotton Tiberius B. v, f.85v.

Romanesque and Continental: BL, Arundel 60, f.13, Cambridge, S-JC, B. 20, f.2v, Oxford, CCC, 157, p.383, BNF, lat. 52, f.50, Auxerre, CT, *The Crucifixion*, BNF, lat. 1618, f.11, Saint-Quentin, CL, 1, p.11, p.41, BL, Harley 4772, f.120v and Avranches, BM, 210, f.19v.

Shoes

Anglo-Saxon: CCCC, 183, f.1v, BodL, Tanner 10, f.115v, BodL, Auct. F. 4. 32, f.1, BL, Cotton Vespasian A. viii, f.2v, BL, Add. 49598, f.118v, BL, Cotton Cleopatra C. viii, f.10v, f.11, f.29, BL, Add. 24199, f.17, CCCC, 23, f.17, f.37v, Munich, SB, Clm. 290316, f.1v, BL, Royal 6, B. viii, f.1v, f.16v, BodL, Junius 11, p.57, p.74, p.84, p.87, BL, Cotton, Vitellius C. iii, f.11v, f.19, Rouen, BM, Y. 6 (274), f.36v, BL, Cotton Julius A. vi, f.4v, f.5, f.5v, BL, Cotton Claudius B. iv, f.15v, f.32, f.38, f.139v, BL, Arundel 155, f.133, CUL, Ff. I. 23, f.4v, BodL, Tanner 3, f.1v, Rouen, BM, A. 27 (368), f.1v, BodL, Douce 296, f.40v, BL, Cotton Tiberius B. v, f.5, f.6v, f.34, f.85v, BL, Stowe 944, f.6, f.6v, f.7, BL, Cotton Tiberius C. iv, f.18v, BL, Cotton Tiberius A. iii, f.2v, f.117v, DCL, B. III. 32, f.56v, BL, Cotton Caligula A. xv, f.122v, BL, Cotton Tiberius C. vi, f.8v, f.9, f.13 and CCCC, 389, f.1v.

Shoes with vamp-stripes

Anglo-Saxon: Munich, SB, Clm. 290316, f.1v, BL, Cotton Vitellius C. iii, f.11v, f.19, BL, Cotton Claudius B. iv, f.139v, BL, Cotton Tiberius B. v, f.5, f.6v, f.34, BL, Cotton Tiberius A. iii, f.2v, BL, Cotton Tiberius C. vi, f.8v, f.9, f.13, CCCC, 389, f.1v and BL, Cotton Caligula A. xv, f.122v.

Romanesque and Continental: Florence, BM-L, Plut. XII. 17, f.2v, Oxford, UC, 165, p.18, p.45, Hildesheim, S-GC, p.19, p.304, PML, M 736, p.15, p.26, CCCC, 393, f.59, CUL, li. 3. 12, f.61v, Amiens, BM, Lescalopier 2, f.11^{ter}, f.11⁶, f.11^{5v}, f.19⁵, BNF, nouv. acq. lat. 1390, f.1v, Dijon, BM, 641, f.40v, Poitiers, BM, 40, f.15v, Quentin, CL, 1, p.9, Perpignan, BM, 1, f.14v, Dijon, BM, 14, f.13v, BNF, lat. 17767, f.11v, Gent, CB-R, 1125 (92), f.168, Douai, BM, 250, f.2, BNF, lat. 116, f.65v, Santiago de Compostela, AC, *Liber Sancti Jacobi*, f.163, BAV, Pal. Lat. 497, f.58v, BNF, lat. 9865, f.5v, Munich, SB, Clm. 28565, f.9v, f.10v, f.11, Valenciennes, BM, 500, f.55, f.60v, f.63, f.64v, Avranches, BM, 210, f.19v, Clermont-Ferand, BM, 1, f.102, Saint-Omer, B, 12, f.5v, Valenciennes, BM, 501, f.5v, Valenciennes, BM, 512, f.4v, Valenciennes, BM, 197, f.4v, f.7, Strasbourg, GS, 37, f.2 and The Hague, KB, 76 F 13, f.20.

Tunics with closely gathered sleeves

Anglo-Saxon: BL, Cotton Claudius B. iv, f.15v, f.32, f.36, f.38, f.139v, BL, Cotton Tiberius B. v, f.5, f.6v, f.34, f.85v, BL, Cotton Vespasian A. viii, f.2v, Rouen, BM, Y. 7 (369), f.54v, CCCC, 23, f.2, f.17v, f.37v, BL, Cotton Cleopatra C. viii, f.10v, f.28v, f.29, BL, Add. 24199, f.17, Munich, SB, Clm. 290316, f.1v, BL, Royal 6, B. viii, f.1v, BodL, Bodley 577, f.1v, BodL, Junius 11, p.57, p.58, p.61, p.84, p.87, BL, Cotton Julius A. vi, f.4v, f.5, f.5v, Rouen, BM, Y. 6 (274), f.36v, f.72, BL, Cotton Titus D. xxvi, f.19v, BL, Cotton Tiberius A. iii, f.2v, f.117v, DCL, B. III. 32, f.56v and BL, Cotton Tiberius C. vi, f.8v, f.9, f.11, f.13, f.17v.

Romanesque: CCCC, 391, p.24, TCC, B. 5. 26, f.1, BL, Arundel 91, f.179, BL, Cotton Vitellius C. xii, f.121, Hildesheim, S-GC, 1, p.48, BL, Cotton Titus, D. xvi, f.34, PML, M 736, p.13, BodL, Bodley 614, f.17v, CUL, Dd. 1. 4, f.220, DCL, A. I. 10, f.227, BL, Lansdowne 383, f.12v, BodL, Auct. F. 6. 5, f.1v, BodL, Bodley 269, f.iii, Oxford, CCC, 157, p.382, p.383, CCCC, 2, f.94, f.147v, Cambridge, PC, 16, f.75, PML, M 521v, TCC, R. 17. 1, f.9, f.20, f.92, f.111, f.283v, BodL, Auct. F. 2. 13, f.4v, f.16, f.47, f.54v, f.85v, DUL, Cosin V.III.1, f.22v, BodL, Auct. E. inf. 1, f.2, Winchester, CL, 17, f.169, f.200v, f.331v, f.350v, PML, M 619 r and v, Winchester, CL, 13, f.51v, Cambridge, S-JC, H. 6, f.iiv, BNF, lat. 10433, f.38, f.193, f.226, GUL, Hunter U. 3. 2, f.9v, f.11v, f.14, f.15v, Copenhagen, RL, Thott 143 2°, f.10, f.11, f.69v, BodL, Gough liturg. 2, f.27, DCL, A. II. 1, f.4, f.16, f.109, f.131v, DCL, A. II. 9, f.63, f.130v and BodL, Laud, Misc. 752, f.146. These are just as numerous in continental examples.

Tunics with rounded necklines, slit front and v-shaped braided border

Romanesque and Continental: TCC, B. 5. 2, f.70, Lincoln, CL, A. 1. 2, f.85v, Lincoln, CL, A. 3. 17, f.8v, BL, Arundel 91, f.179, BodL, Bodley 614, f.50, Cambridge, S-JC, B. 20, f.2v, Copenhagen, RL, Thott. 143 2°, f.69v, Tours, BM, 924, f.1, BAV, Vat. Lat. 3305, f.8v, f.9v, f.11v, Dijon, BM, 168, f.4v, f.88v, Dijon, BM, 135, f.182, BNF, lat. 17767, f.40v, Saint-Omer, B, 12, f.5v and The Hague, KB, 76 F 13, f.28v.

Tunics with wavy necklines

Romanesque and Continental: Oxford, WC, A. 10. 22, f.12v, f.104v, BL, Lansdowne 383, f.15, BNF, lat. 10433, f.193v, BodL, Gough liturg. 2, f.27, BNF, lat. 5058, f.2v, BNF, lat. 7211, f.133v, BNF, nouv. acq. lat. 2246, f.79v, f.122v, Perpignan, BM, 1, f.111v, Dijon, BM, 129, f.5, Verdun, BM, 43, f.28v, Munich, SB, Clm. 28565, f.10 and Moulins, BM, 1, f.4v.

Animals, Birds and Beasts

Birds

Romanesque: BL, Arundel 60, f.52v, BNF, lat. 14782, f.108, TCC, O. 2. 51, f.46, BL, Arundel 16, f.2, BL, Royal 1, B. xi, f.114, GUL, Hunter U. 3. 2, f.15v, CCCC, 2, f.94, f.281v, Cambridge, PC, 120, f.174, Cambridge, S-JC, A. 8, f.1v, f.200v, CUL, Dd. 1. 4, f.121, Winchester, CL, 17, f.200v, BL,

Cotton Nero C. iv, f.9, BodL, Auct. E. inf. 1, f.304, CCCC, 22, f.166 and Norwich, Church of St. Peter Mancroft, f.147.

Cattle

Romanesque: PML, M 521r, BL, Harley 603, f.29v, TCC, R. 17. 1, f.111, CCCC, 4, f.191v and BL, Add. 11283, f.11v.

Dragons

Romanesque: a xi^{ex} sculpture fragment on Wynford Eagle Church, Dorset, Cambridge, CC, 30 (N^o1.8), f.2, Cambridge, S-JC, B. 20, f.2v, BL, Harley 624, f.100, PML, M 777, f.38, BL, Cotton Cleopatra E. i, f.40, Florence, BM-L, Plut. XII. 17, f.3v, f.174v, BodL, Laud, Misc. 247, f.163, TCC, O. 4. 7, f.48v, f.75, BL, Royal 5, D. i, f.1, BL, Arundel 91, f.26v, BodL, Bodley, 271, f.36, BL, Cotton Vitellius C. xii, f.127, Cambridge, PC, 16, f.71v, Cambridge, PC, 120, f.11, Dublin, CBL, 22, f.89v, Hereford, CL, O. 6. XII, f.63v, CUL, Dd 1. 4, f.64v, f.100v, f.220, Cambridge, S-JC, A. 8, f.39v, f.91, BL, Royal 1, B. xi, f.6, CUL, Ii. 3. 12, f.93v, BodL, Auct. E. inf. 1, f.164v, Camarillo, DL, 7, f.81, TCC, O. 2. 51, f.58, f.46, f.91, f.81v, f.100, Copenhagen, RL, Thott 143 2^o, f.69v, CCCC, 22, f.162, DCL, A. II. 9, f.130v and Norwich, Church of St. Peter Mancroft, f.147.

Goats

Romanesque: Cambridge, S-JC, B. 20, f.2v, TCC, R. 17. 1, f.9, f.111, f.182, f.229, CCCC, 2, f.94, Dublin, CBL, 22, f.67v and BL, Add. 11283, f.11v, f.12.

Hogs

Romanesque: BodL, Bodley 130, f.93, BL, Add. 37472v, BodL, Auct. D. 2. 6, f.6v, London LP, 3, f.130, TCC, R. 17. 1, f.9, CCCC, 2, f.94 and PML, M 81, f.36v.

Horses

Romanesque: include: BodL, Bodley 130, f.76, BL, Royal 6, C. vi, f.79v, BodL, Bodley 614, f.17v, TCC, R. 3. 30, f.1, f.6, BL, Arundel 91, f.188, BL, Cotton Titus D. xvi, f.14v, Florence, BM-L, Plut. XII. 17, f.1v, Royal 1. C. viii, f.154v, BL, Harley 603, f.29, f.29v, TCC, R. 17. 1, f.9, f.92, PML, M 724v, BL, Add. 37472r, PML, M 736, p.153, Madrid, BN, Vit 23-8, f.81v, CCCC, 3, f.161v, Winchester, CL, 17, f.350v, PML, M 619v, Copenhagen, RL, Thott 143 2^o, f.10v and PML, M 81, f.13v.

Lions associated with winged beasts

Romanesque: an xi^{ex} capital sculpture in Ely Cathedral, DCL, B. II. 26, f.90, Verdun, BM, 70, f.39v, f.42v, f.54, Cambridge, S-JC, B. 20, f.2v, BL, Cotton Claudius E. v, f.36v, Florence, BM-L, Plut. XII. 17, f.3v, f.211, BL, Cotton Vitellius C. xii, f.134, DCL, A. I. 10, f.227, TCD, 53, f.151, PML, M 736, p.153, CUL, Dd. 1. 4, f.121, f.220, London, Lambeth, PL, 3, f.301v, TCC, R. 17. 1, f.182 and Winchester, CL, 13, f.51v.

Lions with wings

Romanesque: BL, Arundel 60, f.52, BNF, lat. 14782, f.52v, BL, Royal 1, C. vii, f.120v, CCCC, 2, f.281v and BodL, Laud, Misc. 752, f.350.

Sheep

Romanesque: Cambridge, S-JC, B. 20, f.2v, Verdun, BM, 70, f.68v, Oxford, UC, 165, p.18, TCC, R. 17. 1, f.111, BL, Add. 37472r, Dublin, CBL, 22, f.32v, f.67v, GUL, Hunter U. 3. 2, f.9v and BL, Add. 11283, f.12.

Vegetation

Acanthus scroll

Anglo-Saxon: CCCC, 183, London, LP, 200, f.69, BodL, Bodley 577, f.1v, Rouen, BM, Y. 6 (274), f.36v, BL, Harley 76, f.8v, PML, M 708, f.66v, f.67r, Warsaw, BN, I. 3311, f.15, BL, Cotton Claudius B. iv, f.32 and Monte Cassino, AB, BB. 437, 439, p.126, p.127.

Romanesque: TCC, O. 4. 7, f.75, TCC, O.2.51, f.46 and Valenciennes, BM, 4, f.4v.

Cruciform vegetal ornament Type 1b

Anglo-Saxon: BL, Cotton Galba A. xviii, f.21r, BNF, lat. 987, f.43, BL, Harley 603, f.64r, TCC, B. 10. 4, f.10v, Cambridge, PC, 301, f.10v, BAV, Reg. lat. 12, f.62 and PML, M 708, f.66v.

Romanesque: BL, Cotton Nero C. iv, f.24, BNF, lat. 17767, f.11v, Dijon, BM, 132, f.2v and Lille, BM, 33, f.31.

Cruciform vegetal ornament Type 1c

Anglo-Saxon: Hanover, KM, WM XXI^a 36, f.247v and BL, Arundel 155, f.93.

Cruciform vegetal ornament Type 1e

Anglo-Saxon: BL, Cotton Galba A. xviii, f.10r, BNF, lat. 987, f.41, BNF, lat. 6401, f.158v, Boulogne, BM, 11, f.8r, f.10v, BodL, Junius 11, p.7, Rouen, BM, Y. 6 (274), f.72, Cambridge, PC, 301, f.2v, Hanover, KM, WM XXI^a, 36, f.17v and BL, Cotton Tiberius C. vi, f.60.

Romanesque: Oxford, Wadham College, A. 10. 22, f.12v and Boulogne, BM, 2, f.240v.

Cruciform vegetal ornament Type 3

Anglo-Saxon: BL, Cotton Cleopatra C. viii, f.24r, BodL, Junius 11, p.7, TCC, B. 11. 2, f.4, BNF, lat. 987, f.41 and Cambridge, PC, 302, f.1v, f.38r.

Romanesque: TCC, R. 17. 1, f.283v and Tours, BM, 193, f.98.

Interlace

Anglo-Saxon: London, CA, Arundel 22, f.84, Boulogne, BM, 11, f.12r, York Minster, CL, Add. 1, f.23, BL, Add. 34890, f.115, BL, Loan 11, Cambridge, PC, 301, f.11r, BL, Harley 76, f.45, CUL, Ff. I. 23, f.5, f.37v, PML, M 709, f.3r, CCCC, 422, p.51, CCCC, 411, f.1v and BL, Harley 2904, f.4, f.125.

Romanesque: BL, Stowe 2, f.1, Nîmes, BM, 36, f.61v, Grenoble, BM, 17, f.123 and Dijon, BM, 12, f.3v.

Leaf variety Type B (*trifoliolate pointed*)

Anglo-Saxon: BL, Harley 603, f.2, f.25r, BL, Cotton Cleopatra C. viii, f.23v and Cambridge, PC, 302, f.3v.

Romanesque: BL, Cotton Vitellius C. xii, f.134.

Leaf variety Type C (*trifoliolate acanthus*)

Anglo-Saxon: BNF, lat. 7585, f.164, BNF, lat. 987, f.41, London, LP, 200, f.69, BodL, Junius 11, p.58, BL, Royal 1, D. ix, f.11, BL, Harley 76, f.10, Warsaw, BN, I. 3311, f.15, BL, Royal 15, A. xvi, f.84, BAV, Reg. Lat. 12, f.62, CUL, Ff. I. 23, f.5, BL, Cotton Tiberius C. vi, f.72 and TCC, O. 2. 51, f.46.

Romanesque: Cambridge, S-JC, A. 8, f.200v, TCC, B. 3. 4, f.1, DCL, B. II. 16, f.2, Amiens, BM, Lescalopier 2, f.19, Santiago de Compostela, AC, *Libre Sancti Jacobi*, f.163, Paris, BMaz, 1, f.85 and Lyons, BM, 410, f.41v.

Leaf variety Type D (*single-sided acanthus*)

Anglo-Saxon: BodL, Junius 11, p.11, BL, Cotton Julius A. vi, f.5v, BL, Royal 1, D. ix, f.111, BL, Add. 34890, f.10v, Hanover, KM, WM XXI^a 36, f.9v, CCCC, 41, p.246, BodL, Douce 296, f.40, CUL, Ff. I. 23, f.4v, BL, Cotton Claudius B. iv, f.36, TCC, B. 10. 4, f.15r, BodL, Rawlinson C. 570, f.44v, Cambridge, PC, 302, f.3v and BL, Cotton Vespasian A. viii, f.2v.

Romanesque: BL, Cotton Claudius E. v, f.28, BL, Cotton Vitellius, C. xii, f.127, DCL, A. I. 10, f.170, TCC, B. 5. 28, f.87v, Rouen, BM, A. 85 (467), f.118, Paris, BCD, 2, f.164 and Avranches, BM, 159, f.5.

Leaf variety Type E (*trifoliolate rounded*)

Anglo-Saxon: BL, Cotton Galba A. xviii, f.21, BodL, Junius 27, f.135v, BL, Cotton Vespasian A. viii, f.2v, BL, Add. 47967, Fly-leaf (iii), BL, Royal 12, C. xxiii, f.6v, Boulogne, BM, 11, f.12, Warsaw, BN, I. 3311, f.69, Hannover, KM, WM XXI^a, 36, f.10, Cambridge, PC, 301, f.10v, TCC, O. 4. 7, f.48v, Cambridge, PC, 302, f.1r, PML, M 708, f.27r and BodL, Lat. lit. F. 5, f.21v, f.30v.

Romanesque: BL, Harley 603, f.33v and Yale, UL, 414, f.1.

Leaf variety Type F (*heart shaped*)

Anglo-Saxon: BodL, Bodley 579, f.154v, BL, Royal 12, C. xxiii, f.6v and BL, Cotton Julius A. vi, f.5v.

Romanesque: TCD, 53, f.36, BL, Cotton Nero C. iv, f.9, BNF, lat. 8, f.91 and The Hague, KB, 76 F 5, f.15.

Leaf variety Type H (*chilli-type*)

Anglo-Saxon: BL, Cotton Galba A. xviii, f. 10v, BodL, Rawlinson C. 570, f.44v, BL, Royal 12, C. xxiii, f.6v and BL, Cotton Vitellius C. iii, f.56v.

Leaf variety Type I (*serrated*)

Anglo-Saxon: BodL, Bodley 579, f.154v, BL, Cotton Vespasian A. viii, f.2v, TCC, O. 3. 7, f.31, BL, Royal 12, C. xxiii, f.6v, Vercelli, BC, Codex CVII, f.112, BL, Harley 5431, f.54v, London, LP, 200, f.68v, f.69, Salisbury, CL, 38, f.7v, BodL, Junius 11, p.11, BL, Cotton Julius A. vi, f.5v, BodL, Bodley

718, f.1, BL, Arundel 155, f.12, BL, Royal 1, D. ix, f.111, TCC, B. 10. 4, f.10v, f.17v, PML, M 709, f.2v, BodL, Douce 296, f.40, Monte Cassino, AB, BB. 437, 439, p.126, p.127.

Romanesque: BL, Harley 603, f.33r, PML, M 736, p.26 and PML, M 619v.

Leaf variety Type J (*multi-lobed*)

Anglo-Saxon: BL, Cotton Galba A. xviii, f. 120v, BodL, Junius 11, p.13, p.41 and BL, Stowe 2, f.1.

Romanesque: BL, Cotton Claudius E. v, f.49, BL, Harley 624, f.108v, CUL, Dd. 1. 4, f.100v and Djion, BM, 135, f.165.

Leaf variety Type K (*oval lobed*)

Anglo-Saxon and Continental Early Medieval: BNF, lat. 6401A, f.57v and Avranches, BM, 72, f.182v.

Romanesque: Florence, BM-L, Plut. XII. 17, f.211, TCC, R. 15. 22, f. 5v and TCC, B. 3. 4, f.1.

Nodes

Anglo-Saxon: BodL, Junius 11, p.13, BL, Cotton Galba A. xviii, f.21, BL, Cotton Vitellius A. xix, f.9, TCC, B. 11. 2, f.4, BL, Cotton Vitellius C. iii, f.11v, BL, Cotton Claudius B. iv, f.36 and Cambridge, PC, 302, f.1v, f.2r.

Staggered stumps

Anglo-Saxon: BodL, Junius 11, p.13, BL, Harley 603, f.3v, BL, Cotton Claudius B. iv, f.7 and BL, Arundel 60, f.52v.

Romanesque: London, LP, 3, f.6.

Vine Scroll

Anglo-Saxon: BL, Add. 47967, Fly-leaf (iii), TCC, B. 11. 2, f.4, f.106v, BL, Cotton Vitellius C. iii, BL, Cotton Tiberius C. vi, f.18v and PML, M 708, f.43r.

Romanesque: TCC, R. 17. 1, f.283v and Boulogne, BM, 2, f.146.

MANUSCRIPTS CITED

Key to dates:	x/xi	late tenth century/early eleventh century
	xi	eleventh century
	xi ⁱⁿ	early eleventh century
	xi ¹	first half of the eleventh century
	xi ^{1/4}	first quarter of the eleventh century
	xi ^{2/4}	second quarter of the eleventh century
	xi ^{med}	middle of the eleventh century
	xi ²	second half of the eleventh century
	xi ^{3/4}	third quarter of the eleventh century
	xi ^{4/4}	fourth quarter of the eleventh century
	xi ^{ex}	end of the eleventh century

Amiens, Bibliothèque municipale (Amiens, BM)

Amiens, BM, 18, viii/ix (Corbie) – *Corbie Psalter*

Amiens, BM, 19, xii^{ex} (?Amiens) – *Saint-Fuscien Psalter*

Amiens, BM, 143, xii^{2/4} (Corbie) – *Lectionary-Homiliary*

Amiens, BM, Lescalopier 2, xi/xii (Angers) - *Psalter*

Arras, Médiathèque (Arras)

Arras, MS 435, f.1, xi^{2/4} (Arras) – *Arras Bible*

Arras, MS 559, xi^{2/4} (St Vaast, Arras) – *St Vaast Bible*

Arras, MS 721 (1027), xii^{2/4} (Arras) – *Sacramentary fragment*

Autun, Bibliothèque municipale (Autun, BM)

Autun, BM, 132 (S.154), xii^{med} (Autun) - *Sacramentary*

Auxerre, Cathedral Treasury (Auxerre, CT)

Auxerre, CT, s.n., xiiⁱⁿ (Tours) – *Two leaves from a Sacramentary or Missal*

Avesnes, Musée de la Société Archéologique (Avesnes, MSA)

Avesnes, MSA, s.n., xii^{2/4} (Saint-Lambert, Liessies) – *Two leaves from a Gospel Book*

Avranches, Bibliothèque municipale E. Le Héricher (Avranches, BM)

Avranches, BM, 72, xi^{2/4} (Mont-Saint-Michel) – *Patristic texts*

Avranches, BM, 78, x^{4/4} (Mont-Saint-Michel) – *Augustine, Psalms*

Avranches, BM, 107, xi^{med} (Mont-Saint-Michel) – *Bede, St Mark and St Luke*

Avranches, BM, 159, xii^{3/4} (Mont-Saint-Michel) – *Chronicle of Robert of Torigny*

Avranches, BM, 210, xii^{3/4} (Mont-Saint-Michel) – *Cartulary of Mont Saint-Michel*

Bamberg, Staatsbibliothek (Bamberg, SB)

Bamberg, SB, 76, x/xi (Reichenau) – *Bamberg Commentaries*

Bamberg, SB, 140, xiⁱⁿ (Reichenau) – *Bamberg Apocalypse*

Bergues, Bibliothèque Communale (Bergues, BC)

Bergues, BC, 19, xii¹ (Bergues) – *Life and Miracles of St Winnoc and St Oswald;*

Translation of St Leuinna

Berlin, Staatliche Museen, Dahlem, Kupferstichkabinett (Berlin, SM-D-K)
Berlin, SM-D-K, 78 A 4, xii^{2/4} (Saint-Vincent, Metz) – *Sigebert of Gembloux, Passion of St Lucy*

Berlin, Staatsbibliothek Preussischer Kulturbesitz (Berlin, SPK)
Berlin, SPK, theol. Lat. fol. 1, x^{3/4} (Fulda) – *Codex Wittekindeus*
Berlin, SPK, theol. Lat. fol. 34, x^{3/4} (Trier) - *Epistolary of Trier*

Bern, Burgerbibliothek (Bern, BB)
Bern, BB, Cod. 120. II, xii^{ex} (Italian) – *Ebulo Codex*

Besançon, Bibliothèque municipale (Besançon, BM)
Besançon, BM, 14, x^{ex} and xi¹ (?Winchester) - *Gospels*

Bordeaux, Bibliothèque municipale (Bordeaux, BM)
Bordeaux, BM, 1, xi² (Mont Saint-Michel) – *Redon Bible*

Boulogne-sur-Mer, Bibliothèque municipale (Boulogne, BM)
Boulogne, BM, 2, xii² (Saint-André-au-Bois) – *Bible of Saint-André-au-Bois*
Boulogne, BM, 11, x^{ex} (English artist at Saint-Bertin) – *Boulogne Gospels*
Boulogne, BM, 53, xii^{med} (Saint-Bertin) – *St Augustine, City of God*

Bremen, Stadtbibliothek (Bremen, SB)
Bremen, SB, *Book of Pericopes of Henry III*, xi^{2/4} (Echternach) - *Book of Pericopes of Henry III*

Olim Camarillo, Doheny Library (Camarillo, DL) – sold at Christie's in 1987
Camarillo, DL, 7, xii² (?Abbotsbury Abbey) – *Zacharias Chrysopolitanus*

Cambrai, Médiathèque (Cambrai, M)
Cambrai, M, 234, xii^{1/4} (Cambrai) - *Missal*
Cambrai, M, 967, xii^{4/4} (?Paris) – *Gratian, Decretum*

Cambridge, Clare College (Cambridge, CC)
Cambridge, CC, 30 (N^o 1.8), xi^{ex} (Worcester Cathedral Priory)

Cambridge, Corpus Christi College (CCCC)
CCCC, 2, xii^{2/4} (Bury St Edmunds Abbey) – *Bury Bible*
CCCC, 3-4, xii^{med} (Canterbury, Christ Church) – *The Dover Bible*
CCCC, 22, xii^{3/4} (uncertain) – *Isidore, Etymologiae; Bestiary*
CCCC, 23, x^{ex} (?Canterbury, Christ Church) – *Prudentius, Psychomachia and other poems*
CCCC, 41, xi¹ (uncertain) – *Bede, Historia ecclesiastica*
CCCC, 183, x^{2/4} (unknown) – *Bede, Lives of St Cuthbert*
CCCC, 286, vi² (Italian) – *Gospel Book of St Augustine*
CCCC, 389, x^{ex} and xi^{3/4} (Canterbury, St Augustine's) – *St Paul the Hermit; Felix, Life of St Guthlac*
CCCC, 391, xi^{3/4} (Worcester Cathedral Priory) – *St Wulfstan's Portiforium*
CCCC, 393, xii^{2/4} (Ely Cathedral Priory) – *Historia Eliensis*
CCCC, 411, x^{4/4} (Canterbury) - *Psalter*

CCCC, 421, xi^{2/4} (uncertain) – *Anglo-Saxon Homilies*
CCCC, 422, xi^{3/4} (Winchester) – *Missal, Red Book of Darley*

Cambridge, Pembroke College (Cambridge, PC)

Cambridge, PC, 16, xii^{2/4} (Bury St Edmunds Abbey) – *St Gregory the Great, Homilies*
Cambridge, PC, 120, xii^{2/4} (?Bury St Edmunds Abbey) - *Gospels*
Cambridge, PC, 301, xi^{1/4} and xi^{2/4} (uncertain) - *Gospels*
Cambridge, PC, 302, xi^{med} (uncertain) – *Hereford Gospels*

Cambridge, St John's College (Cambridge, S-JC)

Cambridge, S-JC, A. 8, xii^{2/4} (Canterbury, Christ Church) – *Flavius Josephus, Jewish Antiquities*
Cambridge, S-JC, B. 20, xii¹ (?Worcester Cathedral Priory) – *Calendar; Isidore; Homilies*
Cambridge, S-JC, H. 6, xii^{3/4} (?Ramsey Abbey) – *Bede, Apocalypse Commentary*

Cambridge, Trinity College (TCC)

TCC, B. 2. 34, xii¹ (Canterbury, Christ Church) – *Jerome*
TCC, B. 3. 4, xii¹ (Canterbury, Christ Church) – *Jerome*
TCC, B. 5. 2, xi/xii (Lincoln) - *Bible*
TCC, B. 5. 26, xi² (Canterbury, Christ Church) – *Augustine, Commentary on the Psalms*
TCC, B. 5. 28, xi² (Canterbury, Christ Church) – *Augustine*
TCC, B. 10. 4, xi^{1/4} (?Canterbury, Christ Church) – *Trinity Gospels*
TCC, B. 11. 2, x^{3/4} (Canterbury, St Augustine's) - *Amalarius*
TCC, B. 14. 3, x^{4/4} (Canterbury, Christ Church) – *Arator, Historia Apostolica*
TCC, B. 15. 34, xi¹ (Canterbury, Christ Church) – *Anglo-Saxon Homilies*
TCC, B. 16. 3, x¹ (?Canterbury, Christ Church) – *Rabanus Maurus*
TCC, O. 2. 51, xi² (Canterbury, St Augustine's) – *Priscian, Grammar*
TCC, O. 3. 7, x^{3/4} (Canterbury, St Augustine's) - *Boethius*
TCC, O. 4. 7, xii^{1/4} (Rochester Cathedral Priory) – *Jerome, Commentaries on the Old Testament*
TCC, R. 3. 30, xii^{1/4} (Rochester Cathedral Priory) – *Lucan, Pharsalia*
TCC, R. 15. 22, xii^{2/4-3/4} (Canterbury, Christ Church) - *Boethius*
TCC, R. 17. 1, xii^{med} (Canterbury, Christ Church) – *Eadwine Psalter*

Cambridge, Trinity Hall (Cambridge, TH)

Cambridge, TH, 1, xvⁱⁿ (Canterbury, St Augustine's) – *Thomas of Elmham, Speculum Augustinianum*

Cambridge, University Library (CUL)

CUL, Dd. 1. 4, xii^{2/4} (Canterbury, Christ Church) – *Flavius Josephus, Jewish Antiquities*
CUL, Dd. 6. 6, xii^{2/4} (uncertain) – *Boethius, The Consolation of Philosophy*
CUL, Ff. I. 23, xi^{2/4} (?Winchcombe Abbey) – *Winchcombe Psalter*
CUL, Ii. 3. 12, xii^{2/4} (Canterbury, Christ Church) – *Boethius, De Musica, De Arithmetica*

Chantilly, Musée Condé (Chantilly, MC)

Chantilly, MC, 14 b, x^{3/4} (?Trier) - *Registrum Gregorii*

Clermont-Ferrand, Bibliothèque municipale (Clermont-Ferrand, BM)

Clermont-Ferrand, BM, 1, xii^{3/4} (?Central France) – *Clermont-Ferrand Bible*
Clermont-Ferrand, BM, 63, xii^{4/4} (?Clermont-Ferrand) – *Sacramentary*

Copenhagen, Royal Library (Copenhagen, RL)

Copenhagen, RL, G.K.S, 10, 2°, x/xi (uncertain) – *Copenhagen Gospels*
Copenhagen, RL, Thott 143 2°, xii^{3/4} (Northern England or France) – *Psalter*

Darmstadt, Hessische Landesbibliothek (Darmstadt, HL)

Darmstadt, HL, 1640, xi^{1/4} (Cologne) – *Hitda Codex*
Darmstadt, HL, 1948, x^{3/4} (Reichenau) – *Gero Codex*

Dijon, Bibliothèque municipale (Dijon, BM)

Dijon, BM, 2, xii^{2/4} (Saint-Bénigne, Dijon) – *Bible of Saint-Bénigne*
Dijon, BM, 12, xii^{1/4} (Cîteaux) – *Bible of Stephen Harding*
Dijon, BM, 14, xii^{1/4} (Cîteaux) – *Bible of Stephen Harding*
Dijon, BM, 129, xii^{2/4} (Cîteaux) – *Jerome, Commentary on Isaiah*
Dijon, BM, 130, xii^{2/4} (Saint-Vaast, Arras) – *Jerome, Commentary on Jeremiah*
Dijon, BM, 132, xii^{2/4} (Cîteaux) – *Jerome, Commentary on Daniel, Minor Prophets and Ecclesiastes*
Dijon, BM, 135, xii^{1/4} (Cîteaux) – *Jerome, Letters and Sermons*
Dijon, BM, 168, xii^{1/4} (Cîteaux) – *Gregory, Moralia in Job*
Dijon, BM, 169, xii^{1/4} (Cîteaux) – *Gregory, Moralia in Job*
Dijon, BM, 173, xii^{1/4} (Cîteaux) – *Gregory, Moralia in Job*
Dijon, BM, 641, xii^{2/4} (Cîteaux) – *Cîteaux Lectionary*

Douai, Bibliothèque municipale (Douai, BM)

Douai, BM, 250, xii^{med} (Sainte-Rictrude, Marchiennes) – *Augustine, Enarrationes in Psalmos*
Douai, BM, 340, xii^{3/4} (Saint-Sauveur, Anchin) – *Rabanus Maurus, De laudibus sanctae Crucis*

Dublin, Chester Beatty Library (Dublin, CBL)

Dublin, CBL, 22, xii^{2/4} (Walsingham Priory) – *Walsingham Bible*

Dublin, Trinity College (TCD)

TCD, 53, xii^{2/4} (Winchcombe Abbey) – *Winchcombe Psalter*
TCD, A. 1. 6 (58), viii-ix (?Iona) – *Book of Kells*
TCD, A. 4. 5 (57), ?vii² (?Iona) – *Book of Durrow*

Durham, Cathedral Library (DCL)

DCL, A. I. 10, xii^{2/4} (Durham Cathedral Priory) – *Miscellaneous Commentaries*
DCL, A. II. 1, Vol. III, xii² (Durham Cathedral Priory) – *Puisset Bible*
DCL, A. II. 9, xii^{4/4} (Durham Cathedral Priory) – *Peter Lombard*
DCL, B. II. 16, xi/xii (Canterbury, St Augustine's) – *Augustine, In Evangelium Iohannis*
DCL, B. II. 26, xii¹ (Durham Cathedral Priory) – *St Augustine, On the Trinity*
DCL, B. III. 32, xi^{med} (Canterbury, Christ Church) – *Aelfric's Grammar*
DCL, Hunter 100, xii^{1/4} (Durham Cathedral Priory) – *Astronomy; Medicine*

Durham, University Library (DUL)

DUL, Cosin V.III.1, xii^{med} (Durham Cathedral Priory) – *Laurence of Durham, Works*

Épernay, Bibliothèque municipale (Épernay, BM)

Épernay, BM, 1, ix¹ (Hautvillers Abbey, near Reims) - *Ebbo Gospels*

Florence, Biblioteca Mediceo-Laurenziana (Florence, BM-L)

Florence, BM-L, Amiatino 1, viii^{1/4} (Wearmouth-Jarrow) - *Codex Amiatinus*

Florence, BM-L, Plut. XII. 17, xii^{1/4} (Canterbury, ?St Augustine's) – *St Augustine, De Civitate Dei*

Florence, BM-L, Plut. XVII. 20, xi¹ (Canterbury, Christ Church) – *Gospel Lectionary*

Gent, Centrale Bibliotheek van de Rijksuniversiteit (Gent, CB-R)

Gent, CB-R, 1125 (92), xii^{1/4} (Saint-Omer) – *Lambert of Saint-Omer, Liber Floridus*

Glasgow, University Library (GUL)

GUL, Hunter U. 3. 2, xii^{3/4} (Northern England, ?diocese of York) - *Psalter*

Göttingen, Universitätsbibliothek (Göttingen, UB)

Göttingen, UB, MS theol. 231, x² (Fulda) – *Fulda Sacramentary*

Grenoble, Bibliothèque municipale (Grenoble, BM)

Grenoble, BM, 17, xiiⁱⁿ (Grande Chartreuse) - *Bible*

The Hague, Koninklijke Bibliotheek (The Hague, KB)

The Hague, KB, 76 F 5, xii^{ex} (Saint-Bertin) – *Psalter fragment*

The Hague, KB, 76 F 13, xii^{4/4} (?Fécamp or Ham) – *Fécamp Psalter*

Hanover, Kestner Museum (Hanover, KM)

Hanover, KM, WM XXI^a 36, xi^{1/4} (Canterbury, Christ Church) – *Eadwig Gospels*

Heiligenkreuz, Stiftsbibliothek (Heiligenkreuz)

Heiligenkreuz, Cod. 226, xii^{ex} (Burgundy or Champagne, ?Morimond) – *Hugh of Fouilloy, Liber Avium; De volutione rotarum*

Hereford, Cathedral Library (Hereford, CL)

Hereford, CL, O. 5. XI, xii^{2/4} (West Country) – *St John Chrysostom, Commentaries and Homilies*

Hereford, CL, O. 6. XII, xii^{2/4} (?Hereford) - *Psalter*

Hildesheim, Cathedral Treasury (Hildesheim, CT)

Hildesheim, CT, 18, xi^{1/4} (Hildesheim) – *Gospels of Bernward of Hildesheim*

Hildesheim, CT, 688, xi¹ (Reichenau) – *Book of Collects*

Hildesheim, St. Godehard's Church (Hildesheim, S-GC)

Hildesheim, S-GC, 1, xii^{1/4} (St Albans Abbey) – *St Albans Psalter*

Leiden, Bibliotheek der Rijksuniversiteit (Leiden, B-R)

Leiden, B-R, Voss. lat. Q 79, ix^{2/4} (?Lotharingia) – *Leiden Aratea*

Le Mans, Bibliothèque municipale (Le Mans, BM)

Le Mans, BM, 227, xiiⁱⁿ (Le Mans) – *Lives of the Saints*

Lichfield, Cathedral Library (Lichfield, CL)

Lichfield, CL, 1, viii¹ (?Lichfield) - *Lichfield Gospels*

Lille, Archives Départementals du Nord (Lille, ADN)

Lille, ADN, 10 H 323, xii² (Sainte-Rictrude, Marchiennes) – *Cartulary of Marchiennes*

Lille, Bibliothèque municipale (Lille, BM)

Lille, BM, 33, xii^{med} (Saint-Calixte, Cyssoing) - *Gospels*

Lincoln, Cathedral Library (Lincoln, CL)

Lincoln, CL, A. 1. 2, xi/xii (Lincoln) - *Bible*

Lincoln, CL, A. 3. 17, xiiⁱⁿ (Lincoln) – *St Augustine, Sermons*

London, British Library (BL)

BL, Add. 10546, ix^{2/4} (Tours) – *Grandval-Moutier Bible*

BL, Add. 11283, xii^{3/4} (uncertain) - *Bestiary*

BL, Add. 24199, x^{ex} (uncertain) - *Prudentius*

BL, Add. 33241, xi^{2/4} (?Flanders) – *Encomium Emmae reginae*

BL, Add. 34890, xi^{1/4} (uncertain) – *Grimbald Gospels*

BL, Add. 37472 (I), xii^{2/4} (Canterbury, ?Christ Church) – *Picture Leaf*

BL, Add. 40618, viii to ix and x^{med} (uncertain) - *Gospels*

BL, Add. 42497, xii^{ex} (Hohenbourg) – *Scenes of the Life of St John the Baptist*

BL, Add. 47967, x^{2/4} and x² (Winchester) – *Orosius, Universal History*

BL, Add. 49598, x² (Winchester, Old Minster) – *Benedictional of St Æthelwold*

BL, Arundel 16, xi^{4/4} (Canterbury, Christ Church) – *Life of St Dunstan*

BL, Arundel 60, xi^{3/4} and xi^{4/4} (Winchester, ?New Minster) - *Psalter*

BL, Arundel 91, xii^{1/4} (Canterbury, St Augustine's) – *Lives of Saints*

BL, Arundel 155, xi^{1/4} (Canterbury, Christ Church) - *Psalter*

BL, Cotton Caligula A. vii, x² (uncertain) - *Heliand*

BL, Cotton Caligula A. xiv, xi^{med} (uncertain) – *Hereford Troper*

BL, Cotton Caligula A. xv, xi^{3/4} (Canterbury, Christ Church) – *Paschal Tables*

BL, Cotton Claudius B. ii, xii^{4/4} (Canterbury, Christ Church) – *John of Salisbury, Life of Thomas Becket; Letters of Thomas Becket*

BL, Cotton Claudius B. iv, xi^{2/4} (?Canterbury, St Augustine's) – *Old English Hexateuch*

BL, Cotton Claudius E. v, xii¹ (Canterbury, Christ Church) – *Canon Law*

BL, Cotton Cleopatra C. viii, x^{ex} (Canterbury, Christ Church) – *Prudentius, Psychomachia*

BL, Cotton Cleopatra E. i, xii^{1/4} (Canterbury, Christ Church) – *Canterbury privileges*

BL, Cotton Galba A. xviii, x^{2/4} (Winchester, Old Minster) – *Aethelstan Psalter*

BL, Cotton Julius A. vi, xiⁱⁿ and xi^{med} (?Canterbury, Christ Church) – *Calendar and Hymnal*

BL, Cotton Nero C. iv, xii^{med} (Winchester, ?Cathedral Priory of St Swithun) – *Winchester Psalter*

BL, Cotton Nero C. vii, xii¹ (Canterbury, Christ Church) – *Lives of Saints*

BL, Cotton Nero D. ii, xiii^{med} (?Canterbury or Rochester) – *Matthew of Westminster's Flores Historiarum*

BL, Cotton Nero D. iv, vii/viii (Lindisfarne) – *Lindisfarne Gospels*

BL, Cotton Otho B. vi, v^{ex} (?Alexandria or Antinoë) – *Cotton Genesis*

BL, Cotton Tiberius A. iii, xi^{med} (Canterbury, Christ Church) – *Regularis Concordis, Rule of St Benedict*

BL, Cotton Tiberius B. i, xi^{in-med} (?Abingdon) – *Orosius; Menologium; Anglo-Saxon Chronicle*

BL, Cotton Tiberius B. v, xi^{2/4} (?Winchester) – *Calendar; Cicero, Aratea; Marvels of the East*

BL, Cotton Tiberius C. i, xii^{1/4} (Peterborough Abbey) – *Computistic and astrological treatises*

BL, Cotton Tiberius C. vi, xi^{med} (uncertain) – *Tiberius Psalter*

BL, Cotton Titus D. xvi, xii^{1/4} (St Alban's Abbey) – *Prudentius, Psychomachia*

BL, Cotton Titus D. xxvi and xxvii, xi¹ (Winchester, New Minster) – *Prayers; Church Offices; Miscellanea*

BL, Cotton Vespasian A. i, viii^{2/4} (Canterbury, St Augustine's) – *Vespasian Psalter*

BL, Cotton Vespasian A. viii, x^{3/4} (Winchester, New Minster) – *New Minster Charter*

BL, Cotton Vitellius A. xv, x^{ex} (uncertain) – *Marvels of the East*

BL, Cotton Vitellius A. xix, x^{med} (Canterbury, St Augustine's) – *Bede, Lives of St Cuthbert*

BL, Cotton Vitellius C. iii, xiⁱⁿ (Canterbury, Christ Church) – *Herbarium Apulei, Dioscorides; Medicina de quadrupedibus*

BL, Cotton Vitellius C. xii, xii^{1/4} (Canterbury, St Augustine's) – *Martyrology*

BL, Egerton 3314, xi^{ex} (Canterbury) – *Computistica etc*

BL, Harley 76, xi¹ (Canterbury, Christ Church) – *Bury Gospels*

BL, Harley 603, x/xi and xii^{2/4} (Canterbury, Christ Church) – *Utrecht Psalter*

BL, Harley 624, xii¹ (Canterbury, Christ Church) – *Passionale*

BL, Harley 2788, viii/ix (Charlemagne's Ada School) – *Harley 2788 Gospel*

BL, Harley 2826, ix^{med} (Reims) – *Gospel Book*

BL, Harley 2904, x^{4/4} (Winchester) – *Psalter*

BL, Harley 4751, xiii¹ (unknown) – *Bestiary*

BL, Harley 4772, xii^{1/4} and xii^{med or 3/4} (Languedoc) – *Languedocian Bible*

BL, Harley 5102, xiii¹ (unknown) – *Psalter*

BL, Harley 5431, x^{4/4} (Canterbury, St Augustine's) – *Regula St Benedict; Statutes Antiqua*

BL, Lansdowne 383, xii^{2/4} (West Country) – *Shaftesbury Psalter*

BL, Loan 11, xi^{1/4} (?Canterbury, Christ Church) – *Kederminster Gospels*

BL, Royal 1 B. xi, xii^{2/4} (Canterbury, St Augustine's) – *Gospels*

BL, Royal 1 C. vii, xii^{2/4} (Rochester, Cathedral Priory) – *Rochester Bible*

BL, Royal 1 D. ix, xi^{1/4} (Canterbury, Christ Church) – *Gospels*

BL, Royal 1 E. vi, manuscript ix¹, added drawing x/xi (?Canterbury, St Augustine's) – *Gospels*

BL, Royal 5 D. i, xii^{1/4} (Rochester, Cathedral Priory) – *St Augustine, Commentary on Psalms*

BL, Royal 5 F. iii, ix/x (?Mercia) – *Aldhelm*

BL, Royal 6 B. vi, xii¹ (Rochester) – *Ambrose etc*

BL, Royal 6 B. viii, x/xi (?Canterbury, St Augustine's) – *Isidore*

BL, Royal 6 C. vi, xii^{1/4} (Rochester Cathedral Priory) – *Gregory the Great, Moralia in Job*

BL, Royal 10 A. xiii, xii^{3/4} (Canterbury, Christ Church) – *Smaragdus, Commentary on the Rule of St Benedict*

BL, Royal 12 C. xxiii, x² (Canterbury, Christ Church) – *Julian; Aldhelm*

BL, Royal 15 A. xvi, xi^{2/4} (Canterbury, St Augustine's)

BL, Stowe 2 xi^{3/4} (?Winchester, New Minster) - *Psalter*

BL, Stowe 944, xi^{2/4} (Winchester, New Minster) – *New Minster Liber Vitae*

London, College of Arms (London, CA)

London, CA, Arundel 22, x^{4/4} (Winchester) – *Fragment of Gospel Lectionary*

London, Lambeth Palace Library (London, LP)

London, LP, 3, xii^{2/4} (?Canterbury, St Augustine's) – *Lambeth Bible*

London, LP, 200, x^{ex} (Canterbury, St Augustine's) - *Aldhelm*

London, Victoria and Albert Museum (London, V&A)

London, V&A, 661, xii^{2/4} (Canterbury, ?Christ Church) – *Picture leaf*

Los Angeles, Getty Museum (Los Angeles, GM)

Los Angeles, GM, MS 9, x/xi (?Canterbury) – *Gospel Lectionary fragments*

Lyons, Bibliothèque municipale (Lyons, BM)

Lyons, BM, 410, xii^{4/4} (?Lyonnais) - *Bible*

Madrid, Biblioteca Nacional (Madrid, BN)

Madrid, BN, Vit 23-8, xii^{med} (?Winchester Cathedral Priory of St Swithun) - *Psalter*

Madrid, Escorial Library (Madrid, EL)

Madrid, EL, Vitr. 17, xi^{2/4-med} (Echternach) - *Gospels*

Madrid, EL, *Codex Aureus*, xi^{2/4} (Echternach) – *Codex Aureus*

Monte Cassino, Archivio della Badia (Monte Cassino, AB)

Monte Cassino, AB, BB. 437, 439, xi^{med} (uncertain) – *Gospels of Judith of Flanders*

Moulins, Bibliothèque municipale (Moulins, BM)

Moulins, BM, 1, xii^{ex} (Saint-Pierre, Souvigny) – *Souvigny Bible*

Munich, Bayerische Staatsbibliothek (Munich, BSB)

Munich, BSB, Clm. 4452, xi^{1/4} (Reichenau) - *Pericopes Book of Henry II*

Munich, BSB, Clm. 4453, x/xi (Reichenau) - *Gospel Book of Otto III*

Munich, BSB, Clm. 4454, xiⁱⁿ (Reichenau) – *Pericopes Book of Reichenau*

Munich, BSB, Clm. 4456, xi^{1/4} (Regensburg) – *Sacramentary of Henry II*

Munich, BSB, Clm. 13601, xi^{1/4} (Regensburg) – *Uta Codex*

Munich, BSB, Clm. 14000, ix^{3/4} (Court School of Charles the Bald) - *Codex Aureus Gospels*

Munich, BSB, Clm. 28565, xii^{med or 3/4} (Saint-Vincent, Metz) – *Annals of Metz and hagiographical compilation*

Munich, BSB, Clm. 290316, x^{ex} (uncertain) – *Prudentius fragment*

New York, Pierpont Morgan Library (PML)

PML, M 81, xii^{4/4} (?Lincoln) - *Bestiary*

PML, M 44, xii^{3/4} (North Eastern France, ?Corbie) – *Scenes of the Life of Christ*
 PML, M 521, xii^{2/4} (Canterbury, ?Christ Church) – *Picture leaf*
 PML, M 619, xii² (Winchester, Cathedral Priory of St Swithun) – *Winchester Bible leaf*
 PML, M 708, xi^{2/4} (?household of Judith) – *Judith of Flanders Gospels*
 PML, M 709, xi^{2/4} (?household of Judith) – *Judith of Flanders Gospels*
 PML, M 724, xii^{2/4} (Canterbury, ?Christ Church) – *Picture leaf*
 PML, M 736, xii^{2/4} (Bury St Edmunds Abbey) – *Life of St Edmund*
 PML, M 777, xii^{1/4} (uncertain) – *Mostyn Gospels*
 PML, M 827, manuscript s x (?Northern France); added decoration by Anglo-Saxon artist x^{ex} /xi – *Anhalt-Morgan Gospels*
 PML, M 869, x^{4/4} to xiⁱⁿ (Canterbury, Christ Church) – *Arenberg Gospels*

Nîmes, Bibliothèque municipale (Nîmes, BM)

Nîmes, BM, 36, xi^{4/4} to xii^{1/4} (La Grasse) – *Florus, Commentary on the Pauline Epistles*

Norwich, Church of St. Peter Mancroft (Norwich, S-PM)

Norwich, Church of St. Peter Mancroft, xii^{4/4} (?Northern England) – *Epistles of St Paul*

Nürnberg, Germanisches Nationalmuseum (Nürnberg, GNM)

Nürnberg, GNM, 156.142/KG1138, xi^{2/4} (Echternach) - Codex Aureus of Echternach

Oxford, Bodleian Library (Oxford, BodL)

BodL, Auct. D. 1. 13, xii^{med} (?Winchester) – *St Paul, Epistles*
 BodL, Auct. D. 2. 6, xii^{2/4} (St Albans Abbey) - *Calendar*
 BodL, Auct. E. inf. 1, xii^{med} and xii^{4/4} (Winchester) – *Bible: Genesis to Job*
 BodL, Auct. F. 1. 15, x^{ex} (Canterbury, St Augustine's) – *Boethius, De consolatione philosophiae*
 BodL, Auct. F. 2. 13, xii^{med} (St Albans Abbey) - *Terence, Comedies*
 BodL, Auct. F. 4. 32, x^{med} (Glastonbury) – *St Dunstan's Classbook*
 BodL, Auct. F. 6. 5, xii^{2/4} (West Country) – *Boethius, The Consolation of Philosophy*
 BodL, Barlow 40, xii^{2/4 or med} (Southern France) – *Cicero, De inventione rhetorica*
 BodL, Bodley 130, xi/xii (Bury St Edmunds Abbey) – *Herbal and Sextus Placitus, De virtutibus bestiarum in arte medicinae*
 Bodley 155, xiⁱⁿ (Barking) - *Gospels*
 BodL, Bodley 269, xii^{2/4} (?Eynsham Abbey) – *St Augustine, Commentary on Psalms*
 BodL, Bodley 271, xii^{2/4} (Canterbury, Christ Church) – *St Anselm, Works*
 BodL, Bodley 494, xii^{3/4} (uncertain) – *Richard of St Victor, Commentary on the Visions of Ezekiel*
 BodL, Bodley 577, x/xi (Canterbury, Christ Church) – *Aldhelm, De virginitate*
 BodL, Bodley 579, ix^{ex} (?Arras or Cambrai), later additions x¹⁻²⁺ (Canterbury, Christ Church) and xi^{med+} (Exeter) – *Leofric Missal*
 BodL, Bodley 614, xii¹ (uncertain) – *Astronomy; Marvels of the East*
 BodL, Bodley 718, xiⁱⁿ (Canterbury and Exeter) – *Penitential of Egbert, Halitgar*
 BodL, Digby 83, xii^{med} (uncertain) – *Astronomical treatise*
 BodL, Douce 293, xii^{med-3/4} (Northern England) - *Psalter*
 BodL, Douce 296, xi^{2/4} (?Crowland) - *Psalter*
 BodL, Gough liturg. 2, xii^{ex} (Northern England) - *Psalter*

BodL, Junius 11, x^{ex} (?Canterbury, Christ Church) – *Old English Biblical Poetry*
 BodL, Junius 27, x^{2/4} (Winchester) – *Junius Psalter*
 BodL, Lat. lit. F. 5, xi^{2/4} (uncertain) - *St Margaret Gospels*
 BodL, Laud, Misc. 247, xii^{1/4} (uncertain) - *Bestiary*
 BodL, Laud, Misc. 469, xii^{2/4} (uncertain) – *St Augustine, City of God*
 BodL, Laud, Misc. 752, xii^{4/4} and xiiiⁱⁿ (?West Country) - *Bible*
 BodL, Rawlinson B. 484, x^{2/4} (Winchester, Old Minster) – *Miniature from Aethelstan Psalter*
 BodL, Rawlinson C. 570, x² (Canterbury, St Augustine's) – *Arator, Historia apostolica*
 BodL, Tanner 3, xi^{2/4} (?Worcester) – *Gregory the Great, Dialogues*
 BodL, Tanner 10, x¹ (uncertain) – *Bede, Historia ecclesiastica*

Oxford, Corpus Christi College (Oxford, CCC)

Oxford, CCC, 2, xii^{2/4} (?St Albans Abbey) – *Two leaves from a ?Psalter*
 Oxford, CCC, 157, xii^{2/4} (Worcester Cathedral Priory) – *Florence/John of Worcester, Chronicle*

Oxford, St. John's College (Oxford, S-JC)

Oxford, S-JC, 28, x^{med-3/4} (Canterbury, St Augustine's) – *Miscellaneous texts; Gregory the Great, Pastoral Care*

Oxford, University College (Oxford, UC)

Oxford, UC, 165, xii^{1/4} (Durham Cathedral Priory) – *Bede, Life of St Cuthbert*

Oxford, Wadham College (Oxford, WC)

Oxford, WC, A. 10. 22, xi^{ex} (uncertain) - *Gospels*

Paris, Bibliothèque de la Chambre des Députés (Paris, BCD)

Paris, BCD, 2, xii^{med} (Vendôme) - *Bible*

Paris, Bibliothèque de l'École des Beaux-Arts (Paris, BEB-A)

Paris, BEB-A, 12, 13, 15, 16, xii^{2/4} (Saint-Lambert, Liessies) – *Detached leaves from St Basil, Homilies on the Hexameron*
 Paris, BEB-A, 38, xii^{4/4} (Saint-Martin de Canigou) – *Foundation Charter of a Confraternity of Saint-Martin de Canigou*

Paris, Bibliothèque Mazarine (Paris, BMaz)

Paris, BMaz, 1, xii^{1/4} (Limousin) – *Mazarine Bible*

Paris, Bibliothèque nationale de France (BNF)

BNF, lat. 1, ix^{2/4} (Tours) – *Vivian Bible*
 BNF, lat. 2, ix^{3/4} (Saint-Amand) – *Second Bible of Charles the Bald*
 BNF, lat. 6, xi^{2/4} (San-Pedro, Roda) – *Roda Bible*
 BNF, lat. 8, xiiⁱⁿ (Saint-Martial, Limoges) – *Second Bible of Saint-Martial*
 BNF, lat. 52, xi^{4/4} (Saint-Pierre, Moissac) - *Bible*
 BNF, lat. 116, xii^{med} (?Chartres) - *Bible*
 BNF, lat. 254, xi/xii (South Western France) – *New Testament, Codex Colbertinus*
 BNF, lat. 266, ix^{med} (Tours) – *Lothair Gospels*
 BNF, lat. 796, xii^{med} (Montiéramey) - *Breviary*

BNF, lat. 833, xii² (Normandy) – *Premonstratensian Missal*
 BNF, lat. 987, x^{4/4} (Winchester) - *Benedictional*
 BNF, lat. 1141, ix^{3/4} (Metz) - *Sacramentary fragment*
 BNF, lat. 1618, xiiⁱⁿ (South Western France) – *Pseudo-Dionysius, De caelesti hierarchia, De divinis nominibus and De mystica theologia; Pseudo-Quintilianus, Declamationes majores*
 BNF, lat. 1626, xii^{med} (?Sens or Saint-Denis) – *Origen, Homilies on the Old Testament*
 BNF, lat. 2060, xii^{1/4} (?Rhône Valley or Languedoc) – *St Augustine, City of God*
 BNF, lat. 2287, xii^{3/4} (Saint-Amand) – *St Gregory, Epistles*
 BNF, lat. 5058, xi/xii (Saint-Pierre, Moissac) – *Flavius Josephus, De bello Judaico*
 BNF, lat. 5296A, xi/xii (Saint-Martial, Limoges) – *Life of St Martial*
 BNF, lat. 6401, x^{4/4} (English hand at Fleury) - *Boethius, De consolazione Philosophiae*
 BNF, lat. 6401A, x^{ex} (Canterbury, Christ Church) – *Boethius, De consolazione Philosophiae*
 BNF, lat. 7211, xi^{ex} or xiiⁱⁿ (South Central France) – *Musical Theory Collection*
 BNF, lat. 7585, x² (Canterbury, St Augustine's) – *Isidore Etymologia*
 BNF, lat. 8824, xi^{2/4} (uncertain) - *Psalter*
 BNF, lat. 8846, xii^{4/4} and xiv^{med} (Canterbury, Christ Church and Catalonia) – *Psalter*
 BNF, lat. 8850, viii/ix (Charlemagne's Ada School) - *St Médard of Soissons Gospels*
 BNF, lat. 8959, xii^{med} (?Troyes) – *Flavius Josephus, Antiquitates Judaicae and De bello Judaico*
 BNF, lat. 9428, ix^{med} (Metz) – *Drogo Sacramentary*
 BNF, lat. 9438, xiiⁱⁿ (Cathedral of Saint-Étienne, Limoges) – *Sacramentary of Saint-Étienne, Limoges*
 BNF, lat. 9865, xii^{med or 3/4} (Saint-Pierre, Vierzon) – *Cartulary of Vierzon*
 BNF, lat. 10433, xii^{3/4} (uncertain) – *Psalter and Book of Hours*
 BNF, lat. 11534, xii^{4/4} (?Paris) - *Bible*
 BNF, lat. 12054, xiiⁱⁿ (Saint-Maur-des-Fossés) - *Missal*
 BNF, lat. 14516, xii^{3/4} (Saint-Victor, Paris) – *Richard of St Victor, Opera, including In Ezechielem*
 BNF, lat. 14782, xi^{ex} (Exeter Cathedral) – *Exeter Gospels*
 BNF, lat. 15307, xii^{1/4} (Saint-Urbain) – *St Gregory, Moralia in Job*
 BNF, lat. 16730, xii² (North Eastern France, ?Corbie) – *Josephus, Antiquates Judaicae and De Bello Judaicae*
 BNF, lat. 16745, xii^{4/4} (Champagne) – *Capucins Bible*
 BNF, lat. 17716, xii^{ex} (Saint-Martin-des-Champs) – *Liturgical and historical compilation concerning Cluny*
 BNF, lat. 17767, xii^{1/4} (Saint-Pierre, Corbie) – *Martyrology; Rule of St Benedict; Obituary*
 BNF, lat. 17814, x^{ex} (?Canterbury, Christ Church) – *Boethius, De consolazione Philosophiae*
 BNF, nouv. acq. lat. 1203, viii^{4/4} (Charlemagne's Ada School) – *Godescalc Gospel Lectionary*
 BNF, nouv. acq. lat. 1390, xi/xii (Angers) – *Life of St Albinus*

Paris, Bibliothèque Sainte-Geneviève (Paris, BS-G)

Paris, BS-G, 8, xii^{ex} (Champagne) – *Manerius Bible*

Paris, BS-G, 9, xii^{ex} (Champagne) – *Manerius Bible*

Paris, BS-G, 1042, xii^{4/4} (North Eastern France) – *Martianus Capella, De Nuptiis Mercurii et Philologiae*

Parma, Biblioteca Palatina (Parma, BP)

Parma, BP, Pal. 1650, xi^{ex} or xiiⁱⁿ (Cluny) – *Ildefonsus, De virginitate Beatae Mariae*

Perpignan, Bibliothèque municipale (Perpignan, BM)

Perpignan, BM, 1, xii^{1/4} (Roussillon or Catalonia) - *Gospels*

Poitiers, Bibliothèque municipale (Poitiers, BM)

Poitiers, BM, 40, xiiⁱⁿ (Sainte-Radegonde, Poitiers) – *Missal*

Reims, Bibliothèque municipale (Reims, BM)

Reims, BM, 9, xi^{3/4} (uncertain) - *Gospels*

Reims, BM, 18, xii¹ (Saint-Remi, Reims) – *Saint-Remi Bible*

Reims, BM, 23, xii^{2/4} (Saint-Thierry, Reims) - *Bible*

Rome, Abbazia di San Paolo fuori le mura (Rome, SPfM)

Rome, SPfM, *Bible of San Paolo Fuori le Mura*, ix^{3/4} (?Reims)

Rouen, Bibliothèque Municipale (Rouen, BM)

Rouen, BM, A. 5 (7), xii^{1/4} (La Trinité, Fécamp) – *Octateuch, Chronicles and Gospel fragments*

Rouen, BM, A. 6 (8), xiiⁱⁿ (Jumièges) - *Bible*

Rouen, BM, A. 27 (368), xi^{2/4} (Wessex) – *Lanalet Pontifical*

Rouen, BM, A. 85 (467), xi^{ex} (Saint-Ouen) – *Augustine*

Rouen, BM, Y. 6 (274), xi^{1/4} (uncertain) – *Sacramentary of Robert of Jumièges*

Rouen, BM, Y. 7 (369), x^{4/4} (Winchester, New Minster) – *Benedictional of Archbishop Robert*

St Gall, Stiftsbibliothek (St Gall, SB)

St Gall, SB, 51, viii² (Ireland) - *Gospels*

Saint-Omer, Bibliothèque de l'agglomération (Saint-Omer, B)

Saint-Omer, B, 12, xii^{3/4} (Saint-Bertin) – *St Gregory, Moralia in Job*

Saint-Omer, B, 30, xii^{3/4} (Saint-Bertin) – *Zachary of Besançon, Concordances of the Gospels*

Saint-Omer, B, 34, xii^{2/4} (Saint-Bertin) – *Origen, Homilies on the Old Testament*

Saint-Quentin, Chapter Library (Saint-Quentin, CL)

Quentin, CL, 1, xiiⁱⁿ (?Saint-Quentin) – *Life and Miracles of St Quentin*

Santiago de Compostela, Archivo de la Catedral (Santiago de Compostela, AC)

Santiago de Compostela, AC, *Liber Sancti Jacobi*, xii^{med} (?North or Western France)

Salisbury, Cathedral Library (Salisbury, CL)

Salisbury, CL, 38, x^{ex} (Canterbury, ?Christ Church) – *Aldhelm, De virginitate*

Salisbury, CL, 150, x² (South West England) - *Psalter*

Sées, Bibliothèque de l'Évêché (Sées, BÉ)

Sées, BÉ, 5, xii^{2/4} (Saint-Martin de Sées) - *Gospels*

Stockholm, Kungliga Biblioteket (Stockholm, KB)

Stockholm, KB, A.135, viii^{med} (Canterbury) – *Codex Aureus*

Strasbourg, Grand Séminaire (Strasbourg, GS)

Strasbourg, GS, 37, xii^{3/4} (Marbach-Schwarzenthann) – *Codex Guta-Sintram*

Stuttgart, Württembergische Landesbibliothek (Stuttgart, WLB)

Stuttgart, WLB, bibl. 2° 23, ix^{2/4} (Northern France, ?St Germain des Prés) – *Stuttgart Psalter*

Tours, Bibliothèque municipale (Tours, BM)

Tours, BM, 193, xii^{3/4} (Saint-Martin, Tours) - *Sacramentary*

Tours, BM, 291, xiiⁱⁿ (uncertain) – *St Augustine, Homilies on St John*

Tours, BM, 321, xii^{2/4} (uncertain) – *St Gregory, Moralia in Job*

Tours, BM, 924, xii^{1/4} (?Loire Valley) – *Terence, Comedies*

Tours, BM, 1018, xi/xii (Saint-Martin de Tours) – *Vita Martini*

Trier, Stadtbibliothek (Trier, SB)

Trier, SB, 22, viii/ix (Charlemagne's Ada School) – *Ada Gospels*

Trier, SB, 24, x^{4/4} (Reichenau) - *Codex Egberti, Pericopes book*

Trier, SB, 31, viii/ix (Northern France) – *Trier Apocalypse*

Trier, SB, MS 2209/2328, x^{3/4} (Trier) – *St Gregory, Moralia*

Troyes, Bibliothèque municipale (Troyes, BM)

Troyes, BM, 894, xii¹ (Saint-Père de Chartres) – *Missal of Saint-Père, Chartres*

Upsala, University Library (Upsala, UL)

Upsala, UL, *Gospels of Henry III*, xi^{med} (Echternach) – *Gospels of Henry III*

Utrecht, Universiteits Bibliotheek (Utrecht, UB)

Utrecht, BR, 32, ix¹ (Hautvillers Abbey, near Reims) – *Utrecht Psalter*

Valenciennes, Bibliothèque municipale (Valenciennes, BM)

Valenciennes, BM, 1-5, xii^{3/4} (Saint-Amand) – *Sawalo's Bible*

Valenciennes, BM, 75, xii^{1/4} (?Saint-Amand) – *Gospels of St Matthew and St John, Apocalypse and Song of Songs*

Valenciennes, BM, 108, xii^{3/4} (Saint-Amand) - *Sacramentary*

Valenciennes, BM, 197, xii^{3/4} (Saint-Amand) – *Gilbert de la Porrée, Commentary on Boethius' De Trinitate*

Valenciennes, BM, 500, xii² (Saint-Amand) – *Life and Miracles of St Amand*

Valenciennes, BM, 501, xii^{3/4} (Saint-Amand) – *Life and Miracles of St Amand*

Valenciennes, BM, 512, xii^{3/4} (Saint-Amand) – *John the Deacon, Life of St Gregory; St Gregory, Liber Pastoralis; Life and Miracles of St Nicholas; Versified Life of St Faith*

Vatican City, Biblioteca Apostolica Vaticana (BAV)

BAV, Lat. 1269, xii (?Ravenna) – *Homiliary Passionary*

BAV, Pal. Lat. 497, xii^{med} (Notre-Dame, Lixheim) - *Epistolary*
BAV, Reg. Lat. 12, xi^{2/4} (Canterbury, Christ Church) – *Bury Psalter*
BAV, Reg. Lat. 124, ix^{2/4} (Fulda) - *Hrabanus Maurus' De laudibus sanctae cruces*
BAV, Vat. Lat. 3305, xii^{1/4} (South Western France) – *Terence, Comedies*

Vendôme, Bibliothèque municipale (Vendôme, BM)

Vendôme, BM, 193, xii¹ (La Trinité, Vendôme) – *Geoffrey of Vendôme, Works*

Vercelli, Biblioteca capitolare (Vercelli, BC)

Vercelli, BC, Codex CVII, x² (?Rochester) – *Homilies and Poems*

Verdun, Bibliothèque municipale (Verdun, BM)

Verdun, BM, 8, xi/xii (Saint-Airy, Verdun) – *Life of St Airy*
Verdun, BM, 43, xii^{2/4} (Saint-Vanne, Verdun) - *Gospels*
Verdun, BM, 70, xii¹ (St Albans Abbey) – *St Anselm, Prayers and Meditations*
Verdun, BM, 119, xii^{2/4} (Saint-Vanne, Verdun) - *Homiliary*

Vienna, Weltliche Schatzkammer der Hofburg (Vienna, WS-H)

Vienna, WS-H, *Coronation Gospels*, viii^{ex} (Court School of Charlemagne)

Warsaw, Biblioteka Narodowa (Warsaw, BN)

Warsaw, BN, I. 3311, x/xi and xi^{2/4} (uncertain) – *Evangelary*

Winchester, Cathedral Library (Winchester, CL)

Winchester, CL, 13, xii^{3/4} (Winchester) – *Lives of Saints*
Winchester, CL, 17, xii² (Winchester, Cathedral Priory of St Swithun) - *Winchester Bible*

Wolfenbüttel, Herzog August Bibliothek (Wolfenbüttel, HAB)

Wolfenbüttel, HAB, Cod. Guelf. 1 Gud. lat, xii^{3/4} (North Eastern France) – *Lambert of Saint-Omer, Liber Floridus*

Yale University, Beinecke Rare Book and Manuscript Library (Yale, UL)

Yale, UL, 414, xii¹ (South Central France) - *Bible*

York Minster, Chapter Library (York Minster, CL)

York Minster, CL, Add. 1, x/xi (Canterbury, Christ Church) – *York Gospels*

Würzburg, Universitätsbibliothek (Würzburg, UB)

Würzburg, UB, M. p. th. f.69, viii^{ex} (near Würzburg) - *Würzburg Epistles of St Paul*

BIBLIOGRAPHY

- Ables, R., 'Brookland and Fyrd Service in Late Saxon England', *Anglo-Norman Studies* 7 (1984), 1-25.
- Adams, H., *Mont-Saint-Michel and Chartres* (Boston, 1913).
- Addyman, P. V. and Priestley, J., 'Baile Hill, York: A Report on the Institute's Excavations', *The Archaeological Journal* 134 (1977), 115-156.
- Ailes, A., 'Heraldry in Twelfth-Century England: the Evidence', in D. Williams (ed.), *England in the Twelfth Century* (Woodbridge, 1990), 1-16.
- Alcock, N. W. and Buckley, R. J., 'Leicester Castle: the Great Hall', *Medieval Archaeology* 31 (1987), 73-9.
- Alexander, J. J. G., *Norman Illumination at Mont St Michel 966-1100* (Oxford, 1970).
- Alexander, J. J. G., *Insular Manuscripts – 6th to the 9th Century* (London, 1978).
- Alexander, J. J. G., *Medieval Illuminators and their Methods of Work* (New Haven and London, 1992).
- Alexander, J. J. G., 'Ideological Representation of Military Combat in Anglo-Norman Art', *Anglo-Norman Studies* 15 (1992), 1-24.
- Alexander, J. J. G. and Binski, P. (eds.), *Age of Chivalry, Art in Plantagenet England 1200-1400* (London, 1987).
- Amyot, T., 'Observations on an Historical Fact Supposed to be Established by the Bayeux Tapestry', *Archaeologia* 19 (1819), 88-95.
- Amyot, T., 'A Defence of the Early Antiquity of the Bayeux Tapestry', *Archaeologia*, 19 (1819), 192-208.
- Anon., *Illustrated Guide to the Facsimile of the Bayeux Tapestry in the Reading Museum and Art Gallery* (Reading, 1949).
- Archer, T. A., 'The Battle of Hastings', *The English Historical Review* 9/33 (1894), 1-41.
- Armitage, E. S., *Early Norman Castles of the British Isles* (London, 1912).
- Ashley, M., *The Life and Times of William I* (London, 1973).

- Backhouse, J., Turner, D. H and Webster, L. (eds.), *The Golden Age of Anglo-Saxon Art 966-1066* (London, 1984).
- Bachrach, B. S., 'Some Observations on the Military Administration of the Norman Conquest', *Anglo-Norman Studies* 8 (1985), 1-26.
- Bachrach, B. S., 'Some Observations on the Bayeux Tapestry', *Cithara* 27 (1987), 1-28
- Bailey, R. N. and Cramp, R., *Corpus of Anglo-Saxon Stone Sculpture, Volume II, Cumberland, Westmoreland and Lancashire North-of-the-Sands* (Oxford, 1988).
- Barker, P. A., and Barton, K. J., 'Excavations at Hastings Castle, 1968' *Archaeological Journal* 134 (1977), 80-100.
- Barlow, F., *The English Church 1000-1066: A History of the Late Anglo-Saxon Church* (London, 1979).
- Barlow, F., *The Feudal Kingdom of England 1042-1216* (London, 1988).
- Barlow, F., *Edward the Confessor* (London, 1997).
- Barlow, F. (trans.), *The Life of King Edward who rests at Westminster* (Oxford, 1992).
- Barlow, F. (ed. and trans.), *The Carmen de Hastingae Proelio of Guy Bishop of Amiens* (Oxford, 1999).
- Barlow, F., *The Godwins* (Harlow, 2002).
- Barral i Altet, X., *The Romanesque Towns, Cathedrals and Monasteries* (Köln, 2001).
- Bates, D. R., *Odo Bishop of Bayeux 1049 – 1097* (unpublished PhD thesis, Exeter University, 1970).
- Bates, D. R., 'The Character and Career of Odo, Bishop of Bayeux (1049/50-1097)', *Speculum* 50 (1975), 1-20.
- Bates, D. (ed.), *Regesta Regum Anglo-Normannorum, the Acta of William I* (Oxford, 1998)
- Bates, D., *William the Conqueror* (Stroud, 2001).
- Baxter, R., *Bestiaries and Their Users in the Middle Ages* (Stroud, 1998).
- Baylé, M., 'Interlace Patterns in Norman Romanesque Sculpture: Regional Groups and their Historical Background', *Anglo-Norman Studies* 5 (1982), 1-20.
- Baylé, M., 'Réminiscences Anglo-Scandinaves dans la sculpture romane de Normandie', *Anglo-Norman Studies* 13 (1990), 35-48.

- Baylé, M., 'Architecture et enluminure dans le monde normand', in P. Bouet and M. Dosdat (eds.) *Manuscripts et enluminures dans le monde normand (X^e-XV^e siècles)* (1999), 51-68.
- Baylé, M., Bouet, P. *et al.*, *Le Mont-Saint-Michel* (Paris, 1998).
- Baylé, M. and Bouet, P. (eds.), *L'Architecture Normande au Moyen Age*, 2. vols., 2nd ed. (Caen, 2001).
- Beckwith, J., *Ivory Carvings in Early Medieval England* (London, 1972).
- Beeler, J., *Warfare in England 1066-1189* (New York, 1966).
- Bennett, M., *Campaigns of the Norman Conquest* (Oxford, 2001).
- Bennett, M., 'Poetry as History? The Roman de Rou of Wace as a Source for the Norman Conquest', *Anglo-Norman Studies* 5 (1982), 21-39.
- Bennett, P., Frere, S. S. and Stow, S., *Excavations at Canterbury Castle* (Maidstone, 1982).
- Beresford, G., 'Goltho manor, Lincolnshire: the buildings and their surrounding defences c.850-1150', *Anglo-Norman Studies* 4 (1981), 13-36.
- Bernstein, D., 'The Blinding of Harold and the Meaning of the Bayeux Tapestry', *Anglo-Norman Studies* 5 (1982), 40-64.
- Bernstein, D. J., *The Mystery of the Bayeux Tapestry* (London, 1986).
- Bertrand, S., 'The History of the Tapestry', in F. Stenton (ed.) *The Bayeux Tapestry* (1957), 76-85.
- Bertrand, S., *La Tapisserie de Bayeux et la manière de vivre au onzième siècle* (La Pierre-qui-Vire, 1966).
- Bertrand, S. and Lemagnen, S., *The Bayeux Tapestry* (Rennes, 1996).
- Bertrand, S., 'A Study of the Bayeux Tapestry', in R. Gameson (ed.) *The Study of the Bayeux Tapestry* (1997), 31-38.
- Biddle, M., 'Excavations at Winchester, 1965, Fourth Interim Report', *The Antiquaries Journal* 45 (1966), 308-332.
- Blair, J. (ed.), *Minsters and Parish Churches: The Local Church in Transition 950 – 1200* (Oxford, 1998).
- Blair, J., 'The 12th-Century Bishop's Palace at Hereford', *Medieval Archaeology* 31 (1987), 59-72.

- Bone, P., 'The Development of Anglo-Saxon Swords from the Fifth Century to the Eleventh Century' in S. C. Hawkes (ed.), *Weapons and Warfare in Anglo-Saxon England* (1989), 63-70.
- Bosanquet, G. (ed. and trans.), *Eadmer's History of Recent Events in England – Historia Novorum in Anglia* (London, 1964).
- Bouet, P. and Dosdat, M. (eds.), *Manuscripts et enluminures dans le monde normand (X^e-XV^e siècles)* (Caen, 1999).
- Bradbury, J., *The Medieval Archer* (Woodbridge, 1997).
- Bradbury, J., *The Battle of Hastings* (Stroud, 1998).
- Bradley, J., *Illuminated Manuscripts* (London, 1996).
- Bradley, S. A. J. (ed. and trans.), *Anglo-Saxon Poetry* (London, 1995).
- Brilliant, R., 'The Bayeux Tapestry: a stripped narrative for their eyes and ears', in R. Gameson (ed.) *The Study of the Bayeux Tapestry* (1997), 111-37.
- Brindley, H. H., *Impressions and Casts of Seals, Coins, Tokens, Medals and Other Objects of Art Exhibited in the Seal Room, National Maritime Museum* (Greenwich, 1938).
- Brøgger, A. W. and Shetelig, H., *The Viking Ships: Their Ancestry and Evolution* (London, 1971).
- Brooks, F. W., *The Battle of Stamford Bridge* (York, 1963).
- Brooks, N. P., 'Arms, Status and Warfare in Late-Saxon England', in D. Hill (ed.) *Ethelred the Unready*, *British Archaeological Reports (British Series) 59* (1978), 81-103.
- Brooks, N. P. and Walker, H. E., 'The Authority and Interpretation of the Bayeux Tapestry', *Anglo-Norman Studies 1* (1978), 1-34.
- Brooks, N., 'Weapons and Armour', in D. Scragg (ed.), *The Battle of Maldon* (Oxford, 1991), 208-19.
- Brooks, N., *The Early History of the Church of Canterbury* (London, 1996).
- Brown, M. P., *The Lindisfarne Gospels, Society, Spirituality and the Scribe* (London, 2003).
- Brown, R. A., *English Castles* (London, 1976).
- Brown, R. A., 'The Battle of Hastings', *Anglo-Norman Studies 3* (1980), 1-21.
- Brown, R. A., *The Normans and the Norman Conquest* (Woodbridge, 1998).

- Brown, R. A., *The Norman Conquest* (London, 1984).
- Brown, R. A., *Castles, Conquest and Charters – Collected Papers* (Woodbridge, 1989).
- Brown, R. A., ‘Castles of the Conquest’, in his, *Castles, Conquest and Charters* (1989), 65-74.
- Brown, R. A., ‘The Architecture of the Bayeux Tapestry’, in his, *Castles, Conquest and Charters – Collected Papers* (1989), 214-26.
- Brown, S. A., ‘The Bayeux Tapestry: Why Eustace, Odo and William?’, *Anglo-Norman Studies* 12 (1989) 7-28.
- Brown, S. A., *The Bayeux Tapestry, History and Bibliography* (Woodbridge, 1988).
- Brown, S. A. and Herren, M. W., ‘The Adelae Comitissae of Baudri of Bourgeuil and the Bayeux Tapestry’, *Anglo-Norman Studies* 16 (1993), 55-74.
- Bruce-Mitford, R. L. S., *The Sutton Hoo Ship Burial*, 3 vols. (London, 1975-1983).
- Budny, M., ‘The Byrhtnoth Tapestry or Embroidery’, in D. Scragg (ed.), *The Battle of Maldon* (Oxford, 1991), 263-78.
- Budny, M., *Insular, Anglo-Saxon, and Early Anglo-Norman Manuscript Art at Corpus Christi College, Cambridge*, 2 vols. (Kalamazoo, 1997).
- Burgess, G. (trans.), *The Song of Roland* (London, 1990).
- Butler, L. A. S. and Morris, R. K. (eds.) *The Anglo Saxon Church: Papers on History, Architecture and Archaeology in Honour of Dr. H. M. Taylor, CBA Research Report 60* (London, 1986).
- Cahn, W., *Romanesque Manuscripts, the Twelfth Century*, 2 vols. (London, 1996).
- Campbell, A., (ed. and trans.) *Encomium Emmae Reginae* (London, 1949).
- Campbell, J. (ed.), *The Anglo-Saxons* (London, 1991).
- Carver, M. O. H., ‘Contemporary Artefacts Illustrated in Late Saxon Manuscripts’, *Archaeologia* 108 (1986), 117-145.
- Carver, M. O. H. (ed.), *The Age of Sutton Hoo* (Woodbridge, 1992).
- Cassidy, B. (ed.), *The Ruthwell Cross* (Princeton, 1992).
- Cassidy, B. and Wright, R. M. (eds.), *Studies in the Illustration of the Psalter* (Stamford, 2000).

- Chibnall, M. (ed.), *The Ecclesiastical History of Orderic Vitalis*, 6 vols. (Oxford, 1968-1978).
- Chibnall, M., 'Military Service in Normandy before 1066', *Anglo-Norman Studies* 5 (1982), 65-77.
- Chibnall, M., *Anglo-Norman England 1066-1166* (Oxford, 1987).
- Christensen, A. E., *Guide for the Viking Ships* (Oslo, 1970).
- Christensen, A. E., *Centenary of a Norwegian Viking Find: The Gokstad Excavations* (Sandefjord, 1979).
- Christie, A. G., *English Medieval Embroidery* (London, 1938).
- Clapham, A. W., *English Romanesque Architecture Before the Conquest*, 2nd ed. (Oxford, 1964).
- Clark, J., *Saxon and Norman London* (London, 1989).
- Clegg, J., *The Medieval Church in Manuscripts* (London, 2003)
- Clifton-Taylor, A., *The Cathedrals of England* (London, 1974).
- Clutton-Brock, J., 'The Animal Resources' in D. M. Wilson (ed.), *The Archaeology of Anglo-Saxon England* (London, 1976), 373-92.
- Coatsworth, E. and Pinder, M., *The Art of the Anglo-Saxon Goldsmith, Fine Metalwork in Anglo-Saxon England: Its Practice and Practitioners* (Woodbridge, 2002).
- Cohen, A. S., *The Uta Codex, Art, Philosophy, and Reform in Eleventh-Century Germany* (Pennsylvania, 2000).
- Coldstream, N., *Mason and Sculptors* (London, 1991).
- Collins, M., *Medieval Herbals, the Illustrated Traditions* (London, 2000).
- Combes, P. and Lyne, M., 'Hastings, Haestingaceaster and Haestingaport', *Sussex Archaeological Collections* 133 (1995), 213-24.
- Cook, D. R., 'The Norman Military Revolution in England', *Anglo-Norman Studies* 1 (1978), 94-102.
- Coss, P., *The Knight in Medieval England 1000-1400* (Stroud, 1993).
- Coulson, C., *Castles in Medieval Society: Fortresses in England, France and Ireland in the Central Middle Ages* (Oxford, 2003).

- Coward, D., *A History of French Literature from Chanson de geste to Cinema* (Oxford, 2002).
- Cowdrey, H. E. J., 'Towards an Interpretation of the Bayeux Tapestry', *Anglo-Norman Studies* 10 (1987), 49-66.
- Cowgill, J., De Neergaard, M. and Griffiths, N., *Knives and Scabbards*, 2nd ed. (London, 2003).
- Cramp, R., *Grammar of Anglo-Saxon Ornament – A General Introduction to the Corpus of Anglo-Saxon Stone Sculpture* (Oxford, 1991).
- Cramp, R., *Corpus of Anglo-Saxon Stone Sculpture, Volume I, County Durham and Northumberland*, 2 vols. (London, 1984).
- Croome, A., 'The Viking Ship Museum at Roskilde: Expansion Uncovers Nine More Early Ships; and Advances Experimental Ocean-sailing Plans', *The International Journal of Nautical Archaeology* 28.4 (1999), 382-93.
- Crossley-Holland, K. (trans.), *The Anglo-Saxon World, An Anthology, Including the Complete Beowulf*, 2nd ed. (Oxford, 1999).
- Crowfoot, E., Pritchard, F. and Staniland, K., *Textiles and Clothing c.1150 – c.1450* (London, 1992).
- Crumlin-Pedersen, O., 'Cargo Ships of Northern Europe AD 800-1300', *Conference on Waterfront Archaeology in North European Towns* 2 (1983), 83-93.
- Crumlin-Pedersen, O. and Olsen, O. (eds.), *The Skuldelev Ships* 1 (Roskilde, 2002).
- Darlington, R. R. and McGurk, P., 'The Chronicon ex Chronicis of Florence of Worcester and its Use of Sources for English History before 1066', *Anglo-Norman Studies* 5 (1982), 185-196.
- Darlington, R. R. and McGurk, P. (eds.), *The Chronicle of John of Worcester*, vol. II (Oxford, 1995).
- Davis, R. H. C., 'The Carmen de Hastingae Proelio', *English Historical Review* 367 (1978), 241-61.
- Davis, R. H. C., Engels, L. J. *et al.*, 'The Carmen de Hastingae Proelio: a discussion', *Anglo-Norman Studies* 2 (1979), 1-20.
- Davis, R. H. C., 'William of Jumièges, Robert Curthose and the Norman Succession', *English Historical Review* 95 (1980), 597-606.
- Davis, R. H. C., 'The Warhorses of the Normans', *Anglo-Norman Studies* 10 (1987), 67-82.

- Davis, R. H. C., 'Did the Anglo-Saxons have Warhorses?' in S. C. Hawkes (ed.), *Weapons and Warfare in Anglo-Saxon England* (Oxford, 1989), 141-4.
- Davis, R. H. C. and Chibnall, M. (ed. and trans.), *The Gesta Guillelmi of William of Poitiers* (Oxford, 1998).
- Deanesly, M., *The Pre-Conquest Church in England* (London, 1961).
- Déceneux, M., *The Mont-Saint-Michel, Stone by Stone* (Rennes, 1996).
- Delgado, J. P., (ed.) *British Museum Encyclopaedia of Underwater and Marine Archaeology* (London, 1997).
- Demmin, A., *Arms and Armour, From the Earliest Period to the Present Time* (London, 1877).
- Denhman, R., *The Benedictional of Æthelwold* (Princeton, 1995).
- Denny, N. and Flimer-Sankey, J., *The Bayeux Tapestry, The Norman Conquest 1066* (London, 1985).
- de Palol, P. and Hirmer, M., *Early Medieval Art in Spain* (London, 1967).
- DeVries, K., *The Norwegian Invasion of England in 1066* (Woodbridge, 1999).
- Dickinson, T. and Härke, H., 'Early Anglo-Saxon Shields', *Archaeologia* 110 (1992), 1-94.
- Dodwell, C. R., *Anglo-Saxon Art, a new perspective*, (Oxford, 1985).
- Dodwell, C. R., *The Canterbury School of Illumination 1066-1200* (Cambridge, 1954).
- Dodwell, C. R., *The Pictorial Arts of the West 800-1200* (New Haven and London, 1993).
- Dodwell, C. R. and Clemoes, P., *The Old English Illustrated Hexateuch, Early English Manuscripts in Facsimile XVIII* (Copenhagen, 1974).
- Dodwell, C. R., 'The Bayeux Tapestry and the French Secular Epic', in R. Gameson (ed.) *The Study of the Bayeux Tapestry* (1997), 47-62.
- Douce, F., 'Translation of a Memoir on the Celebrated Tapestry of Bayeux, by the Abbé de la Rue', *Archaeologia* 17 (1814), 85-109.
- Douglas, D. C., *William the Conqueror* (London, 1997).
- Douglas, D. C. and Greenaway, G. W., (eds.) *English Historical Documents II, 1042-1189* (London, 1981).

- Drake, C. S., *The Romanesque Fonts of Northern Europe and Scandinavia* (Woodbridge, 2002).
- Dufty, A. R., *Arms and Armour in England* (London, 1969).
- Dyer, W. H., *Hastings Castle* (Hastings, 1962).
- Eales, R. and Sharpe, R. (eds.), *Canterbury and the Norman Conquest: Churches, Saints and Scholars 1066-1109* (London, 1995).
- Eden, C. H., *Black Tornai Fonts in England, the Group of Seven Late Norman Fonts from Belgium* (London, 1909).
- Edge, D. and Paddock, J. M., *Arms and Armour of the Medieval Knight* (London, 1988).
- Egan, G. and Pritchard, F., *Dress Accessories c.1150 – c.1450* (London, 1991).
- Emms, R., 'The Historical Traditions of St Augustine's Abbey Canterbury', in R. Eales and R. Sharpe (eds.) *Canterbury and the Norman Conquest* (1995), 159-68.
- Emms, R., 'The Scribe of the Paris Psalter', *Anglo-Saxon England* 28 (1999), 179-84.
- Erlande-Brandenburg, A., Pernoud, R., Gimpel, J. and Bechmann, R., *Carnet de Villard de Honnecourt* (Paris, 1986).
- Evans, A. C., *The Sutton Hoo Ship Burial* (London, 1994).
- Farrell, A. W., 'The Use of Iconographic Material in Medieval Ship Archaeology, in McGrail (ed.), *Medieval Ships and Harbours* (1979), 227-46.
- Fenwick, V., (ed.) *The Graveney Boat* (Greenwich, 1978).
- Fernie, E., *The Architecture of the Anglo-Saxons* (London, 1983).
- Fernie, E., 'Saxons, Normans and their Buildings', *Anglo-Norman Studies* 21 (1998), 1-10.
- Ffoulkes, C. J., 'European Arms and Armour', *Historical Association Leaflet*, 88 (1928-35), 1-16.
- Flambard Héricher, A-M., 'Fortifications de Terre et Résidences en Normandie (XI^e-XIII^e Siècles)', *Château Gaillard* 20 (2002), 87-100.
- Foreville, R. (trans.), 'William of Poitiers, Histoire de Guillaume le Conquérant', in S. Morillio (ed.) *Battle of Hastings* (1996), 3-15.
- Fowke, F. R., *The Bayeux Tapestry, A History and Description* (London, 1913).
- Foys, M., *Bayeux Tapestry Digital Edition* (un-published version, 2002).

- Freeman, E. A., *William the Conqueror* (London, 1888).
- Freeman, E., 'The Authority of the Bayeux Tapestry', in R. Gameson (ed.) *The Study of the Bayeux Tapestry* (1997), 7-15.
- Freeman, E., 'The Ælfgyva of the Bayeux Tapestry', in R. Gameson (ed.) *The Study of the Bayeux Tapestry* (1997), 15-18.
- Fuglesang, S. H., *Some Aspects of the Ringerike Style* (Odense, 1980).
- Gaborit-Chopin, D., *Ivories du Moyen Age* (Fribourg, 1978).
- Galliou, P. and Jones, M., *The Bretons* (Oxford, 1991).
- Gameson, R., 'The Romanesque Crypt Capitals of Canterbury Cathedral', *Archaeologia Cantiana* 110 (1992), 17-48.
- Gameson, R., 'The Decoration of the Tanner Bede', *Anglo-Saxon England* 21 (1992), 115-60.
- Gameson, R. G., 'The Romanesque Artist of the 603 Harley Psalter', *English Manuscript Studies 1100-1700* 4 (1993), 24-61.
- Gameson, R., 'English Manuscript Art in the Late Eleventh Century: Canterbury and its Context', in R. Eales and R. Sharpe (eds.) *Canterbury and the Norman Conquest* (1995), 95-144.
- Gameson, R. (ed.), *The Study of the Bayeux Tapestry* (Woodbridge, 1997).
- Gameson, R., *Saint Augustine of Canterbury* (Canterbury, 1997).
- Gameson, R. (ed.), *St Augustine and the Conversion of England* (Stroud, 1999).
- Gameson, R., *The Role of Art in the late Anglo-Saxon Church* (Oxford, 1995).
- Gameson, R., *The Codex Aureus: An Eighth-Century Gospel Book, Stockholm, Kungliga Bibliotek, A.135, Early English Manuscripts in Facsimile XXVIII and XXIX*, 2 vols. (Copenhagen, 2002).
- Garmonsway, G. N. (trans.), *The Anglo-Saxon Chronicle* (London, 1965).
- Gardiner, M., 'Shipping and Trade between England and the Continent during the Eleventh Century', *Anglo-Norman Studies* 22 (1999), 71-94.
- Garnet, G., 'Coronation and Propaganda: Some Implications of the Norman Claim to the Throne of England in 1066', *Royal Historical Society Transactions* 36 (1985), 91-116.

- Geake, H., 'Burial Practice in Seventh- and Eighth-Century England' in M. O. H. Carver (ed.) *The Age of Sutton Hoo* (1995), 83-94.
- Geake, H., 'Portable Antiquities Scheme, Medieval Britain and Ireland, 2000', *Medieval Archaeology* 45 (2001), 236-51.
- Geake, H., 'Portable Antiquities Scheme, Medieval Britain and Ireland, 2001', *Medieval Archaeology* 46 (2002), 128-45.
- Gem, R. D. H., 'The Romanesque Rebuilding of Westminster Abbey', *Anglo-Norman Studies* 3 (1981), 33-60.
- Gem, R., 'Towards an Iconography of Anglo-Saxon Art', *Journal of the Warburg and Courtauld Institutes* 46 (1983), 1-18.
- Gem, R., 'English Romanesque Architecture', in G. Zarnecki *et al.* (ed.), *English Romanesque Art 1066-1200* (1984), 27-40.
- Gem, R., 'The English Parish Church in the 11th and early 12th Centuries', in J. Blair, *Minsters and Parish Churches: The Local Church in Transition 950 – 1200* (1998), 21-30.
- Gem, R. (ed.), *St Augustine's Abbey Canterbury* (London, 1997).
- Gibbs-Smith, C. H., 'Notes on the Plates', in F. Stenton (ed.) *The Bayeux Tapestry* (1957), 162-176.
- Gibbs-Smith, C. H., *The Bayeux Tapestry* (London, 1973).
- Gibson, M. T. Heslop, T. A. and Pfaff, R. W. (eds.), *The Eadwine Psalter, Text, Image, and Monastic Culture in Twelfth-Century Canterbury* (London & University Park, 1992).
- Gifford, E. and Gifford, J., 'The Sailing Performance of Anglo-Saxon Ships as Derived from the Building and Trials of Half-Scale models of the Sutton Hoo and Graveney Ship Finds', *The Mariner's Mirror, The Journal of the Society for Nautical Research* 82/2 (1996), 131-53.
- Gillmor, C., 'Naval Logistics of the Cross-Channel Operation, 1066', in S. Morillo (ed.), *The Battle of Hastings* (1996), 113-28.
- Glover, R., 'English Warfare in 1066' in S. Morillo (ed.) *The Battle of Hastings* (Woodbridge, 1996), 173-88.
- Godfrey, J., *The Church in Anglo-Saxon England* (Cambridge, 1962).
- Goldschmidt, A., *An Early Manuscript of the Aesop Fables of Avianus* (Princeton, 1947).
- Goldschmidt, A., *German Illumination* (New York, 1970).

- Gombrich, E. H., *Art and Illusion*, 4th ed. (London, 1972).
- Gombrich, E. H., *The Story of Art*, 15th ed. (London, 1995).
- Goodburn, D., 'Fragments of a 10th-Century Timber Arcade from Vintner's Place on the London Waterfront', *Medieval Archaeology* 37 (1993), 78-92.
- Grabar, A. and Nordenfalk, C., *Early Medieval Painting - From the Fourth to the Eleventh Century* (Lausanne 1957).
- Graham-Campbell, J., *Viking Artefacts, A Select Catalogue* (London, 1980).
- Graham-Campbell, J., *The Viking World* (London, 1989).
- Graham-Campbell, J., 'Anglo-Scandinavian Equestrian Equipment in Eleventh-Century England', *Anglo-Norman Studies* 14 (1991), 77-90.
- Graham-Campbell, J. (ed.), *Cultural Atlas of the Viking World* (Oxford, 1994).
- Gransden, A., *Historical Writings in England c.550 to c.1307* (London, 1974).
- Gransden, A. (ed.), *Bury St Edmunds: Medieval Art, Architecture, Archaeology and Economy*, British Archaeological Association Conference Transactions 20 (Leeds, 1998).
- Grape, W., *The Bayeux Tapestry* (Munich, 1994).
- Gravett, C., *Norman Knight 950-1204 AD* (London, 1993).
- Gravett, C., *Hastings 1066, the Fall of Saxon England* (London, 1996).
- Gravestock, P., 'Did Imaginary Animals Exist?', in D. Hassig (ed.), *The Mark of the Beast* (1999), 119-35.
- Greenaway, D. (ed. and trans.), *Henry, Archdeacon of Huntingdon Historia Anglorum - The History of the English People* (Oxford, 1996).
- Grew, F. and de Neergaard, M., *Shoes and Pattens* (London, 1988).
- Griffiths-Pedley, J., *Greek Art and Archaeology* (London, 1998).
- Gullick, M., 'The Illuminator of Gloucester', *English Manuscript Studies 1100-1700* 5 (1995), 209-13.
- Gullick, M., 'Professional Scribes in Eleventh- and Twelfth-Century England', *English Manuscript Studies 1100-1700* 7 (1998), 1-24.
- Gurney, H., 'Observations on the Bayeux Tapestry', *Archaeologia* 18 (1817), 359-70.

- Hagen, A., *A Second Handbook of Anglo-Saxon Food and Drink, Production and Distribution*, 2nd ed. (Hockwold cum Wilton, 1999).
- Haist, M., 'The Lion, Bloodline and Kingship', in D. Hassig (ed.), *The Mark of the Beast* (1999), 3-16.
- Hall, R., *The Viking Dig: The Excavations at York* (London, 1986).
- Hall, R., *Viking Age York* (London, 1994).
- Hart, C., 'The Bayeux Tapestry and Schools of Illumination at Canterbury', *Anglo-Norman Studies* 22 (1999), 117-68.
- Harrison, M., *Anglo-Saxon Thegn AD 449-1066* (Oxford, 1993).
- Haseloff, G., *Email im Frühen Mittelalter – Frühchristliche Kunst von der Spätantike bis zu den Karolingern* (Marburg, 1990).
- Haskins, C. H., 'King Harold's Books', *English Historical Review* 37 (1922), 398-400.
- Hassig, D., *The Mark of the Beast* (London, 1999).
- Hattat, R., *Brooches of Antiquity* (Oxford, 1994).
- Hawkes, S. C. (ed.), *Weapons and Warfare in Anglo-Saxon England* (Oxford, 1989).
- Haywood, J., *Dark Age Naval Power, A Reassessment of Frankish and Anglo-Saxon Seafaring Activity*, 2nd ed. (Hockwold-cum-Wilton, 1999).
- Heitz, C., 'The Iconography of Architectural Form', in L. A. S. Butler and R. K. Morris (eds.) *The Anglo Saxon Church*, CBA Research Report 60 (1986), 90-100.
- Henderson, G., *From Durrow to Kells – The Insular Gospel Books 650-800* (London, 1987).
- Henige, C., 'Putting the Bayeux Tapestry in Its Place', in G. Owen-Crocker (ed.) *Harold II Godwinsson and the Bayeux Tapestry* (forthcoming).
- Henson, D., *A Guide to Late Anglo-Saxon England from Ælfred to Eadgar II* (Hockwold-cum-Wilton, 1998).
- Herren, M. W. (trans.), 'Baudri de Bourgueil, Adelae Comitissae', in S. A. Brown (ed.) *The Bayeux Tapestry, History and Bibliography* (1988), 167-77.
- Heslop, T. A., 'A Dated Late Anglo-Saxon Illuminated Psalter', *Antiquaries Journal* 72 (1992), 171-4.

- Heslop, T. A., 'The Production and Artistry of the Bury Bible', in A. Gransden (ed.) *Bury St Edmunds, Medieval Art, Architecture, Archaeology and Economy* (1998), 172-85.
- Hewitt, J., *Ancient Armour and Weapons* (London, 1996).
- Hicks, C. (ed.), *England in the Eleventh Century* (Stamford, 1992).
- Hicks, C., 'The Borders of the Bayeux Tapestry', in her (ed.), *England in the Eleventh Century* (1992), 251-65.
- Hicks, C., *Animals in Early Medieval Art* (Edinburgh, 1993).
- Higham, N. J., *The Kingdom of Northumbria AD 350-1100* (Stroud, 1993).
- Higham, N. J., *The Death of Anglo-Saxon England* (Stroud, 1997).
- Higham, R. and Barker, P., *Hen Domen Montgomery, A Timber Castle on the English-Welsh Border*, 2 vols (Leeds, 1982)
- Higham, R. and Barker, P., *Timber Castles* (London, 1992).
- Higham, R. and Barker, P., *Hen Domen Montgomery, A Timber Castle on the English-Welsh Border* (Exeter, 2000)
- Hill, D., 'The Bayeux Tapestry: The Case of the Phantom Fleet', *Bulletin of the John Rylands University Library* 80, 1 (1998), 23-31.
- Hill, D. (ed.), *Ethelred the Unready*, British Archaeological Reports (British Series) 59 (Oxford, 1978).
- Hinton, D., *Catalogue of the Anglo-Saxon Ornamental Metalwork 700-1100 in the Department of Antiquities, Ashmolean Museum* (Oxford, 1974).
- Hinz, H., 'Zu zwei Darstellungen auf dem Teppich von Bayeux', *Château Gaillard* 6 (1973), 107-120
- Hirokazu, T., 'Three Knights Depicted on the Bayeux Tapestry', *Rekishi, Tohoku Historical Journal* 64 (1985), 38-74.
- Holden, A. J. (ed. and trans.), *Le Roman de Rou de Wace*, 3 vols. (Paris, 1970-3).
- Holden, S., *From Excavation to Reconstruction at West Stow Anglo-Saxon Village* (Bury St Edmunds, 1997).
- Hollander, L. M. (trans.), *Heimskringla, History of the Kings of Norway* (Austin, 1964).
- Holmes, M. R., 'The Bayeux Tapestry, A Comprehensive Survey', *Medieval Archaeology* 1 (1957), 178-82.

- Holmes, U. T., 'The Houses of the Bayeux Tapestry', *Speculum* 34 (1959), 179-183.
- Hooper, N., 'Anglo-Saxon Warfare on the Eve of the Conquest: A Brief Survey', *Anglo-Norman Studies* 1 (1978), 84-93.
- Hooper, N., 'The Housecarls in England in the Eleventh Century', *Anglo-Norman Studies* 7 (1984), 161-76.
- Hutchinson, G., *Medieval Ships and Shipping* (London, 1994).
- Hyland, A., *The Medieval Warhorse from Byzantium to the Crusades* (Stroud, 1996).
- John, E., 'Edward the Confessor and the Norman Succession', *The English Historical Review* 371 (1979), 241-67.
- Jones, S. R. and Smith, J. T., 'The Great Hall of the Bishop's Palace at Hereford', *Medieval Archaeology* 4 (1961), 69-80.
- Kahn, D., *Canterbury Cathedral and its Romanesque Sculpture* (London, 1991).
- Kahn, D. (ed.), *The Romanesque Frieze and its Spectator* (London, 1992).
- Kahn, D., 'Anglo-Saxon and Early Romanesque Frieze Sculpture in England', in D. Kahn (ed.), *The Romanesque Frieze and its Spectator* (1992), 61-74.
- Kauffmann, C. M., *Romanesque Manuscripts, 1066-1190* (London, 1975).
- Keefer, S., 'Body Language: a Graphic Commentary by the Horses of the Bayeux Tapestry', in G. Owen-Crocker (ed.) *Harold II Godwinsson and the Bayeux Tapestry* (forthcoming).
- Kelly, S. E., *Charters of St Augustine's Abbey Canterbury and Minster-in-Thamet* (Oxford, 1995).
- Kenyon, J. R., *Medieval Fortifications* (Leicester, 1990).
- Kerr, M. and Kerr, N., *Anglo-Saxon Architecture* (Aylesbury, 1983).
- Kessler, H., *The Illustrated Bibles from Tours* (Princeton, 1977).
- Keynes, S. (ed.), *The Liber Vitae of the New Minster and Hythe Abbey Winchester, Early English Manuscripts in Facsimile XXVI* (Copenhagen, 1996).
- Kidd, P., 'A Re-examination of the Date of an Eleventh Century Psalter from Winchester, in B. Cassidy and R. M. Wright (eds.) *Studies in the Illustration of the Psalter* (2001), 42-54.
- Kielland, E. C., *Depth and Movement: Stave Churches and Viking Ships Studied in Light of Egyptian-Greek Methods* (Oslo, 1981).

Kiff, J., 'Images of War, Illustrations of Warfare in Early Eleventh-Century England', *Anglo-Norman Studies*, 7 (1984), 177-94.

King, D., 'Embroidery and Textiles', in J. Alexander and P. Binski (eds.), *Age of Chivalry, Art in Plantagenet England 1200-1400* (1987), 157-61.

King, D. J. C., *Castellarium Anglicanum* (London, 1983).

Kirmeier, J., Schneidmüller, B., Weinfurter, S. and Brockhoff, E., *Kaiser Henrich II, 1002-1024* (Augsburg, 2002).

Klingender, F., *Animals in Art and Thought to the end of the Middle Ages* (London, 1971).

Koehler, W., *Die Karolingischen Miniaturen Im Auftrage des Deutschen Vereins für Kunstwissenschaft, Die Schule von Tours I*, 2 vols. and folio (Berlin, 1930 and 1963).

Koehler, W., *Die Karolingischen Miniaturen Im Auftrage des Deutschen Vereins für Kunstwissenschaft II*, 1 vol. and folio (Berlin, 1958).

Koehler, W. and Mütterich, F., *Die Karolingischen Miniaturen: Die Schule von Reims VI*, 2 vols. (Berlin, 1994).

Kölzer, T. and Stähli, M., *Liber ad Honorem Augusti, Sive de Rebus Siculis Cod 120 II der Burgerbibliothek Bern* (Sigmaringen, 1994).

Krautheimer, R., 'Introduction to an Iconography of Mediaeval Architecture', *Journal of the Warburg and Courtauld Institute* 5 (1942), 1-33.

Laffetay, J. D., 'Notice historique et descriptive sur la Tapisserie dite de la Reine Mathilde, Exposée à la Bibliothèque Bayeux' (Bayeux, 1885).

Lampl, P., 'Schemes of Architectural Representation in Early Medieval Art', *Marsyas: Studies in the History of Art* 9 (1961), 6-13.

Lang, J., *Anglo-Saxon Sculpture* (Aylesbury, 1988).

Lang, J., *Corpus of Anglo-Saxon Stone Sculpture, Volume III, York and Eastern Yorkshire* (Oxford, 1991).

Lang, J., *Corpus of Anglo-Saxon Stone Sculpture, Volume VI, Northern Yorkshire* (Oxford, 2001).

Lasko, P., *Ars Sacra 800-1200* (Harmondsworth, 1972).

Lasko, P., 'The Bayeux Tapestry and the Representation of Space', in Owen-Crocker and Graham (eds.) *Medieval Art, Recent Perspectives* (1998) 26-39.

Lawson, M. K., *The Battle of Hastings 1066* (Stroud, 2002).

- Leahy, K., *Anglo-Saxon Crafts* (Stroud, 2003).
- Lebecq, S., 'England and the Continent in the Sixth and Seventh Centuries: the Question of Logistics', in Gameson (ed.), *St Augustine* (1999), 50-67.
- Lemmon, C. H., 'The Campaign of 1066', in D. Whitelock, D. C. Douglas, C. H. Lemmon and F. Barlow, *The Norman Conquest, Its Setting and Impact* (1966), 77-122.
- Le Patourel, J., 'The Norman Succession, 996-1135', *The English Historical Review* 339 (1971), 225-49.
- Le Patourel, N., 'The Norman Conquest, 1066, 1106, 1154?', *Anglo-Norman Studies*, 1 (1978), 103-120.
- Lepelley, R., 'A Contribution to the Study of the Inscriptions in the Bayeux Tapestry: *Bagias* and *Wilgelm*', in R. Gameson (ed.) *The Study of the Bayeux Tapestry* (1997), 39-45.
- Lethaby, W. R., 'The Perjury at Bayeux', in R. Gameson (ed.) *The Study of the Bayeux Tapestry* (1997), 19-20.
- Lewis, S., *The Rhetoric of Power in the Bayeux Tapestry* (Cambridge, 1999).
- Ling, R., *Roman Painting* (Cambridge, 1991).
- Lingard, J., *The History and Antiquities of the Anglo-Saxon Church* (London, 1845).
- Lockett, L., 'An Integrated Re-examination of the Dating of Oxford, Bodleian Library, Junius 11', *Anglo-Saxon England* 31 (2002), 141-74.
- MacGregor, A., *Anglo-Scandinavian Finds from Lloyds Bank, Pavement and Other Sites, Archaeology of York* 17/3 (York, 1982).
- Maclagen, E., *The Bayeux Tapestry* (London, 1945).
- MacLean, D., 'The Date of the Ruthwell Cross', in B. Cassidy (ed.) *The Ruthwell Cross* (1992), 49-70.
- Mann, J., 'Arms and Armour', in F. Stenton (ed.), *The Bayeux Tapestry* (London 1957), 56-69.
- Mann, J., *Arms and Armour in England from the Early Middle Ages to the Civil War* (London, 1969).
- Mann, V. B., 'Architectural Conventions on the Bayeux Tapestry', *Marsyas: Studies in the History of Art* 17 (1975), 59-66.

- Marignan, A., 'Une visite à l' Abbaye de Fleury à St Benoît-sur-Loire', *Revue de l'Art Chrétien*, 4. 13 (1902), 291-305
- Marwood, G. W., *The Story of Holy Trinity Church Bosham* (Selsey, 1995).
- Mayr-Harting, H., *Ottoman Book Illumination, An Historical Study*, 2 vols (London, 1991).
- McGrail, S., *The Building and Trials of the Replica of an Ancient Boat: The Gokstad Faering 1* (Greenwich, 1974).
- McGrail, S. (ed.), *Medieval Ships and Harbours in Northern Europe*, British Archaeological Reports (International Series) 66 (Greenwich, 1979).
- McGrail, S., *The Ship* (London, 1981).
- McGurk, P., and Rosenthal, J. 'The Anglo-Saxon Gospelbooks of Judith, Countess of Flanders: their Text, Make-up and Function', *Anglo Saxon England* 24 (1995) 251-308.
- McLynn, F., *1066, The Year of the Three Battles* (London, 1998).
- McNeill, T. E. and Pringle, M., 'A Map of Mottes in the British Isles', *Medieval Archaeology* 41 (1997), 220-2.
- McNulty, J. B., 'The Lady Aelfgyva in the Bayeux Tapestry', *Speculum* 1v (1980), 659-68.
- McNulty, J. B., *The Narrative Art of the Bayeux Tapestry Master* (New York, 1989).
- Merhautová, A., 'Der St. Wenzelshelm', *Bimonthly of the Institute of the History of Art of the Czechoslovak Academy of Sciences* 20/3 (1992), 170-8.
- Messent, J., *The Bayeux Tapestry Embroiderers' Story* (Thirsk, 1999).
- Metz, P., *The Golden Gospels of Echternach* (London, 1957).
- Milne, G. and Goodburn, D., 'The Early Medieval Port of London AD 700-1200', *Antiquity* 64 (1990), 629-36.
- Mitchell, B. and Robinson, F. C., *A Guide to Old English*, 5th ed. (Oxford, 1995).
- Montier, E. and Chirol, P., *L' Abbaye de Jumièges* (Rouen, 1923).
- Morillio, S., (ed.) *The Battle of Hastings* (Woodbridge, 1996).
- Mortet, V., *Receuil de texts relatifs a l'histoire de l'architecture...en France au Moyen Age*, I (Paris, 1911).

- Morris, C. A., *Craft, Industry and Everyday Life: Wood and Woodworking in Anglo-Scandinavian and Medieval York, The Archaeology of York, The Small Finds, 17/13* (York, 2000).
- Morrison, J. S., Cumlin-Pedersen, O. and van der Heide, G., *Aspects of the History of Wooden Shipbuilding* (Greenwich, 1970).
- Morton, C. and Muntz, H., (eds.) *The Carmen de Hastingsae Prolio of Guy Bishop of Amiens* (Oxford, 1972).
- Musset, L., *Normandie romane, La Haute-Normandie*, 2nd ed. (Saint-Léger-Vauban, 1985).
- Musset, L., *La Tapisserie de Bayeux*, 2nd ed. (Paris, 2002).
- Mütherich, F., and Gaehde, J. E., *Carolingian Painting* (London, 1977).
- Mynors, R. A. B, Thomson, R. M., and Winterbottom, M., (ed. and trans.) *William of Malmesbury, Gesta Regum Anglorum, The History of the English Kings*, Vol. 1 (Oxford, 1998).
- Myrhøj, H. M. and Gøthche, M., *The Roskilde Ships* (Roskilde, 1997, www.natmus.dk).
- Neumann, J., 'Hydrographic and Ship-Hydrodynamic Aspects of the Norman Invasion, AD 1066', *Anglo-Norman Studies* 11 (1988), 221-244.
- Nevinson, J. L., 'The Costumes', in F. Stenton (ed.), *The Bayeux Tapestry* (London, 1957) 70-5.
- Nicolaysen, N., *The Viking Ship Discovered at Gokstad in Norway* (Christiania, 1992).
- Nicolle, D., *The Normans* (Oxford, 1999).
- Noel, W., *The Harley Psalter* (Cambridge, 1995).
- Nordenfalk, C., *Celtic and Anglo-Saxon Painting*, 4th ed. (New York, 1995).
- Nordenfalk, C., *Codex Caesareus Upsaliensis, an Echternach Gospel-Book of the Eleventh Century* (Stockholm, 1971).
- North, J. J., *English Hammered Coinage 1, Early Anglo-Saxon to Henry III c.600-1272*, 3rd ed. (London, 1994).
- Oakeshott, W., *The Artists of the Winchester Bible* (London, 1945).
- O'Connor, K., 'Motte Castles in Ireland: Permanent Fortresses, Residences and Manorial Centres', *Château Gaillard* 20 (2002), 173-82.

- O'Conner, S. A., 'Catalogue of Scandinavian Mail', in D. Tweedle, *The Anglian Helmet from Coppergate, The Archaeology of York* 17/8 (1992), 1183-1187.
- O'Conner, T. P., *Bones from Anglo-Scandinavian Levels at 16-22 Coppergate, The Archaeology of York, The Animal Bones* 15/3 (York, 1989).
- Ohlgren, T. H. (ed.), *Anglo-Saxon Textual Illustration* (Kalamazoo, 1992).
- Okasha, E., *Hand-List of Anglo-Saxon Non-Runic Inscriptions* (Cambridge, 1971).
- Olsen, O. and Crumlin-Pedersen, O., 'The Skuldelev Ships', *Acta Archaeologica* 38 (1967), 74-153.
- Olsen, O. and Crumlin-Pedersen, O., *Five Viking Ships from Roskilde Fjord* (Copenhagen, 1978).
- Ottaway, P., *Excavations and Observations on the Defences and Adjacent Sites, 1971-90, The Archaeology of York, 3/3* (York, 1996).
- Ottaway, P. and Rogers, N., *Craft, Industry and Everyday Life: Finds from Medieval York, The Archaeology of York, The Small Finds* 17/15 (York, 2002).
- Owen-Crocker, G. R., *Dress in Anglo-Saxon England* (Manchester, 1986).
- Owen-Crocker, G. R., 'The Bayeux Tapestry: Culottes, Tunics and Garters, and the Making of the Bayeux Tapestry', *Costume* 28 (1994), 1-9.
- Owen-Crocker, G. R., 'Hawks and Horse Trappings: the Insignia of Rank', in D. Scragg (ed.), *The Battle of Maldon* (Oxford, 1991), 220-37.
- Owen-Crocker, G. R., 'The Bayeux 'Tapestry': Invisible Seams and Visible Boundaries', *Anglo-Saxon England* 31 (2002) 257-74.
- Owen-Crocker, G. R., 'Telling a Tale: Narrative Techniques in the Bayeux Tapestry and the Old English Epic Beowulf', in Owen-Crocker and Graham (eds.) *Medieval Art, Recent Perspectives* (1998) 40-59.
- Owen-Crocker, G. R., 'Brothers, Rivals and the Geometry of the Bayeux Tapestry', in G. Owen-Crocker (ed.) *Harold II Godwinsson and the Bayeux Tapestry* (forthcoming).
- Owen-Crocker, G. R. and Graham, T. (eds.), *Medieval Art, Recent Perspectives, A Memorial Tribute to C. R. Dodwell* (Manchester, 1998).
- Palol, P. and Hirmer, M., *Early Medieval Art in Spain* (London, 1967).
- Pächt, O., *The Rise of Pictorial Narrative in Twelfth-Century England* (Oxford, 1962).

- Pächt, O. and Alexander, J. J. G., *Illuminated Manuscripts in the Bodleian Library Oxford, 3, British, Irish and Icelandic Schools* (Oxford, 1973).
- Pächt, O., *Book Illumination in the Middle Ages* (London, 1986).
- Patterson, B. R., *Harold and William, The Battle for England 1064-1066* (Stroud, 2002).
- Payne, A., *Medieval Beasts* (London, 1990).
- Peacock, J., *Costume 1066-1990s* (London, 1994).
- Peers, C., *Pevensy Castle, Sussex* (London, 1989).
- Pesel, L. F. and Newberry, E. W., *A Book of Old Embroidery* (London, 1921).
- Pesel, L. F., *Double-Running or Back-Stitch* (London, 1931).
- Pesel, L. F., *Leaves from My Embroidery Note-Books* (London, 1938).
- Pétard, M., 'L' Homme de 1066, le combattant d' Hastings', *Galette des Uniformes* 32 (1976), 19-29.
- Pierce, I., 'Arms, Armour and Warfare in the Eleventh Century', *Anglo-Norman Studies* 10 (1987), 237-58.
- Pitt, J., *The Church of St Laurence Bradford on Avon, A Short Guide* (Bradford on Avon, 1998).
- Pollington, S., *The Warrior's Way, England in the Viking Age* (London, 1994).
- Pollington, S., *The English Warrior from Earliest Times to 1066* (Hockwold-cum-Wilton, 1996).
- Pollitt, J. J., *Art in the Hellenistic Age* (Cambridge, 1986).
- Pollock, J., *Bosham: Ecclesia as shown in the Bayeux Tapestry* (Selsey, 1995).
- Pollock, J., *Harold: Rex* (Bosham, 1996).
- Prentout, C., 'An Attempt to Identify Some Unknown Characters in the Bayeux Tapestry', in R. Gameson (ed.) *The Study of the Bayeux Tapestry* (1997), 21-30.
- Prescott, A., *The Benedictional of St Æthelwold* (London, 2001).
- Pritchard, F., 'Footwear', in A. Vince (ed.) *Aspects of Saxo Norman London: II Finds and Environmental Evidence* (London, 1991) 213-40.
- Puhle, M. (ed.), *Otto der Grosse, Magdeburg und Europa, 2. vols* (Mainz, 2001).

Racinet, P. and Droin, L., 'From the Carolingian Residence to the Moat: the Castral and Prioral Complex of Boves (France, Somme area) from the 9th-10th to the 12th-13th century', *Château Gaillard* 20 (2002), 207-26.

Rackham, J., *Animal Bones* (London, 1994).

Raleigh Radford, C. A., Jope, E. M. and Tonkin, J. W., 'The Great Hall of the Bishop's Palace at Hereford', *Medieval Archaeology* 17 (1973), 78-86.

Ramage, N. H. and Ramage, A., *Roman Art* (London, 1995).

Reid, P., 'Knowing People Through their Feet: The Shoes of Lundenburg', *London Archaeologist* 9/10 (2001) 267-74.

Renn, D. F., *Norman Castles in Britain* (London, 1973).

Renn, D. F., 'Canterbury Castle in the Early Middle Ages', in P. Bennett, S. S. Frere, and S. Stow, *Excavations at Canterbury Castle* (1982), 70-7.

Renn, D. F., 'Burhgeat and Gonfanon: Two Sidelights from the Bayeux Tapestry', *Anglo-Norman Studies* 16 (1993), 177-198.

Renoux, A., 'Castle and Power in the County of Maine: the Mayenne Area from the last third of the 9th century to the early 12th century', *Château Gaillard* 20 (2002), 235-45.

Reynolds, A., *Later Anglo-Saxon England: Life and Landscape* (Stroud, 1999).

Richards, J. D., *Viking Age England* (London 1994).

Robinson, J. A., *Gilbert Crispin Abbot of Westminster, A Study of the Abbey Under Norman Rule* (Cambridge, 1911).

Robinson, P., 'Some Late Saxon Mounts from Wiltshire', *The Wiltshire Archaeology and Natural History Magazine* 85 (1992), 63-9.

Ronay, G., 'Edward Aetheling, Anglo-Saxon England's Last Hope', *History Today* 34 (1984), 43-51.

Ronay, G., *The Lost King of England, the East European Adventures of Edward the Exile* (Woodbridge, 1989).

Rowley, T., *The Norman Heritage* (London, 1983).

Rowley, T., *Norman England* (London, 1997).

Rowley, T., *The Normans* (Stroud, 1999).

Rud, M., *La Tapisserie de Bayeux et la bataille du Pommier Gris* (Bayeux, 1976).

- Salch, C. L., *Dictionnaire des châteaux et des fortifications du moyen âge en France* (Strasbourg, 1979).
- Searle, E. (ed. and trans.), *The Chronicle of Battle Abbey* (Oxford, 1980).
- Scheller, R. W., *Exemplum: Model-Book Drawings and the Practice of Artistic Transmission in the Middle Ages (ca. 900 – ca. 1450)* (Amsterdam, 1995).
- Schiller, G., *Iconography of Christian Art II, The Passion of Jesus Christ* (London, 1972).
- Schwartz, M., 'The Buildings in the Bayeux Tapestry: Their Context and Relationship to Contemporary Manuscript Art' (unpublished MA thesis, University of York, 1994).
- Scragg, D. (ed.), *The Battle of Maldon* (Oxford, 1991),
- Sharpe, J. (trans.) and Stevenson, J. (ed.), *William of Malmesbury, A History of the Norman Kings (1066-1125) with the Historia Novella of History of His Own Times (1126-1142)*, 2nd ed. (Felinfach, 2000)
- Sherlock, D. and Woods, H., *St. Augustine's Abbey: Report on Excavations, 1960-78* (Maidstone, 1998).
- Short, I., 'The Language of the Bayeux Tapestry Inscription', *Anglo-Norman Studies* 23 (2000), 267-280.
- Siddorn, J. K., *Viking Weapons and Warfare* (Stroud, 2000).
- Sjøvold, T., *The Oseberg Find and Other Viking Ship Finds* (Oslo, 1957).
- Slocombe, G., *William the Conqueror* (London, 1959).
- Smith, J. T., Faulkner, P. A. and Emery, A., *Studies in Medieval Domestic Architecture* (Leeds, 1975).
- Southern, R. W., *St Anselm and his Biographer* (Cambridge, 1963).
- Sørensen, A. C., *Ladby, A Danish Ship-Grave from the Viking Age* (Roskilde, 2001).
- Staniland, K., *Embroiderers* (London, 1991).
- Stenton, F. M., *The Bayeux Tapestry* (London, 1957).
- Stenton, F., *Anglo-Saxon England* (Oxford, 1985).
- Stephenson, I. P., *The Anglo-Saxon Shield* (Stroud, 2002).
- Stevenson, J. (trans.), *Florence of Worcester, A History of the Kings of England*, 2nd ed. (Felinfach, 1996)

- Stevick, R. D., *The Earliest Irish and English Bookarts, Visual and Poetic Forms Before AD 1000* (Pennsylvania, 1994).
- Stothard, C., 'Some Observations on the Bayeux Tapestry', *Archaeologia* 19 (1819), 184-91.
- Strickland, M., *Anglo-Norman Warfare, Studies in Late Anglo-Saxon and Anglo-Norman Military Organisation and Warfare* (Woodbridge, 1992).
- Swanton, M. J., *The Spearheads of the Anglo-Saxon Settlements* (Leeds, 1973).
- Swanton, M. J., 'A Corpus of Pagan Anglo-Saxon Spear Types', *British Archaeological Reports* 7 (1974), 1-24.
- Tanner, L. E. and Clapham, A. W., 'Recent Discoveries in the Nave of the Westminster Abbey', *Archaeologia* 83 (1933), 227-36.
- Tatton-Brown, T., 'Westminster Abbey: Archaeological Recording at the West End of the Church', *The Antiquaries Journal* 75 (1995), 171-88.
- Tatton-Brown, T., 'The Churches of Canterbury Diocese in the 11th Century', in J. Blair, *Minsters and Parish Churches: The Local Church in Transition 950 – 1200* (1998), 105-18.
- Taylor, A., 'Belrem', *Anglo-Norman Studies* 14 (1992), 1-23.
- Taylor, H. M. and Taylor, J., *Anglo-Saxon Architecture*, 3 vols. (Cambridge, 1965-78).
- Temple, E., *Anglo-Saxon Manuscripts 900-1066* (London, 1976).
- Temple, O. and Temple, R. (trans.), *Aesop the Complete Fables* (London, 1998).
- Teviotdale, E., and Cohen, A., 'The Getty Anglo-Saxon Leaves and New Testament Illustration around the Year 1000', *Scriptorium* 53 (1999), 63-81.
- Thomas, B. and Gamber, O., *Katalog der Leibrustkammer I. Teil Kunsthistorisches Museum* (Vienna, 1976).
- Thomas, M., Avril, F., and Schlag, W., *The Hunting Book of Gaston Phebus* (London, 1998).
- Thomson, R. M. and Winterbottom, M., *William of Malmesbury, Gesta Regum Anglorum, The History of the English Kings, Vol II* (Oxford, 1999).
- Thomson, R. M., *Manuscripts from St Albans Abbey 1066-1235* (Woodbridge, 1982).
- Thorvildsen, K., *The Viking Ship of Ladby* (Copenhagen, 1975).
- Thurlby, M., *The Hereford School of Romanesque Sculpture* (Logaston, 2000).

- Tweddle, D. and Hall, R., *Viking Ships* (York, 1987).
- Tweddle, D., *The Anglian Helmet from Coppergate, The Archaeology of York 17/8* (London, 1992).
- Tweddle, D. Biddle, M. and Kjølbye-Biddle, B., *Corpus of Anglo-Saxon Stone Sculpture, Volume IV, South-East England* (Oxford, 1995).
- Underwood, R., *Anglo-Saxon Weapons and Warfare* (Stroud, 1999).
- Valentine, L. N., *Ornament in Medieval Manuscripts* (London, 1965).
- van der Horst, K., Noel, W. and Wüstefeld, C. M., (eds.) *The Utrecht Psalter in Medieval Art* (Utrecht, 1996).
- van der Horst, K., 'The Utrecht Psalter: Picturing the Psalms of David', in van der Horst, K., Noel, W. and Wüstefeld, C. M., (eds.) *The Utrecht Psalter in Medieval Art* (1996), 22-84.
- Van Houts, E. M. C., *The Gesta Normannorum Ducum: a History Without an End, Anglo-Norman Studies 3* (1980), 106-18.
- Van Houts, E. M. C., 'The Ship List of William the Conqueror', *Anglo-Norman Studies 10* (1987), 159-84.
- Van Houts, E. M. C. (ed. and trans.), *The Gesta Normannorum Ducum of William of Jumieges, Orderic Vitalis, and Robert of Torigni, 2 vols.* (Oxford, 1992-1995).
- Van Moé, E. A., *Illuminated Initials in Medieval Manuscripts* (London, 1950).
- Vince, A. (ed.), *Aspects of Saxo Norman London: II Finds and Environmental Evidence* (London, 1991).
- Walker, I. W., *Harold: The Last Anglo-Saxon King* (Stroud, 1997).
- Walton, P., *Textiles, Cordage and Raw Fibre from 16-22 Coppergate, The Archaeology of York 17/5* (York, 1989).
- Wamers, E., *Die Frühmittelalterlichen Lesefunde aus der Löhrstrasse (Baustelle Hilton II) in Mainz* (Mainz, 1994).
- Wamers, E., 'Karolingerzeit' in B. van J. Hoops (ed.) *Fibel und Fibeltracht* (1995), 586-602.
- Waterman, D. M., 'Late Saxon, Viking, and Early Medieval Finds from York', *Archaeologia 97* (1959) 59-105.
- Webster, L. and Backhouse, J. (ed.), *The Making of England: Anglo-Saxon Art and Culture AD 600-900* (London, 1991).

- Weidemann, K., (ed.) *Das Reich der Salier 1024-1125* (Sigmaringen, 1992).
- Weitzmann, K. and Kessler, H. L., *The Cotton Genesis, British Library Codex Cotton Otho B. vi* (Princeton, 1986).
- Welch, M., *Anglo-Saxon England* (London, 1994).
- Werner, A., (ed.) *London Bodies* (London, 1988).
- White, A., *Antiquities from the River Witham* (Lincoln, 1979).
- White, T. H. (trans.), *The Book of Beasts* (New York, 1984).
- Whitelock, D., (ed.) *English Historical Documents I, 500-1042* (London, 1955).
- Whitelock, D., Douglas, D. C., Lemmon, C. H. and Barlow, F., *The Norman Conquest, Its Setting and Impact* (London, 1966).
- Whitelock, D., Brett, M. and Brooke, C. N. L., (eds.) *Councils and Synods with Other Documents Relating to the English Church I, AD 871-1204, Part 1, 871-1066* (Oxford, 1981).
- Willemsen, C. A. *Das Falkenbuch Kaiser Friedrich II* (Dortmund, 1991).
- Williams, A., 'Some Notes and Considerations on Problems Connected with the English Royal Succession, 860-1066', *Anglo-Norman Studies* 1 (1978), 144-67.
- Williams, A., 'Land and Power in the Eleventh Century: the Estates of Harold Godwinson', *Anglo-Norman Studies* 3 (1980), 171-87.
- Williams, A., and Martin, G. H., *Domesday Book* (London, 1992).
- Williams, D., *Late Saxon Stirrup Strap Mounts, A Classification and Catalogue* (York, 1997).
- Wilson, D. M., *Anglo-Saxon Ornamental Metalwork 700-1100 in the British Museum* (London, 1964).
- Wilson, D. M. (ed.), *The Archaeology of Anglo-Saxon England* (London, 1976).
- Wilson, D. M., *Anglo-Saxon Art, from the Seventh Century to the Norman Conquest* (London, 1984).
- Wilson, D. M., *The Bayeux Tapestry* (London, 1985).
- Wilson, E., *Early Medieval Designs* (London, 1998).
- Wingfield Digby, G., 'Technique and Production', in F. Stenton (ed.), *The Bayeux Tapestry* (1957), 37-55.

- Wood, M., *Norman Domestic Architecture* (Leeds, 1974).
- Woodman, F., *The Architectural History of Canterbury Cathedral* (London, 1981).
- Woodman, F., 'The Waterworks Drawings in the Eadwine Psalter', in M. Gibson, T. A. Heslop. and R. W. Pfaff (eds.), *The Eadwine Psalter* (1992), 168-77.
- Wormald, F., 'Decorated Initials in English Manuscripts from AD 900 to 1100', *Archaeologia* 91 (1945), 107-35.
- Wormald, F., *English Drawings of the Tenth and Eleventh Centuries* (London, 1952).
- Wormald, F., *The Miniatures in the Gospels of St Augustine, Corpus Christi College MS 286* (Cambridge, 1954).
- Wormald, F., 'Style and Design', in F. Stenton (ed.), *The Bayeux Tapestry* (1957), 25-36.
- Wormald, F., 'The Inscriptions', in F. Stenton (ed.), *The Bayeux Tapestry* (1957), 177-80.
- Yapp, W. B., 'Animals in Medieval Art: the Bayeux Tapestry as an Example', *Journal of Medieval History* 13/1 (1987), 15-74.
- Zarnecki, G., 'Romanesque Sculpture in Normandy and England in the Eleventh Century', *Anglo-Norman Studies* 1 (1978), 168-190.
- Zarnecki, G. et al. (ed.), *English Romanesque Art, 1066-1200* (London, 1984).

APPENDIX ILLUSTRATIONS

Appendix Illustration: Tapestry Buildings 1, 2, 3 and 4

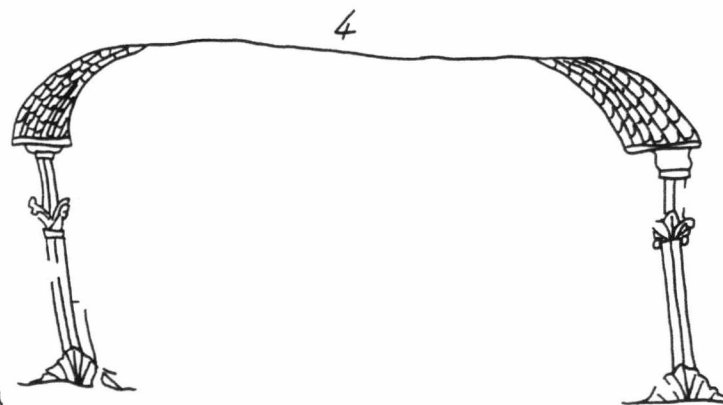
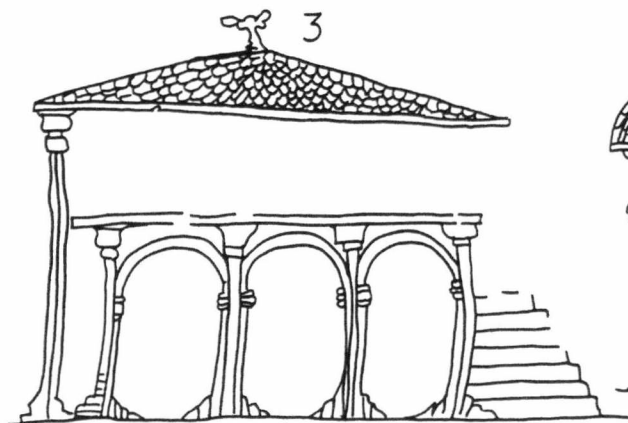
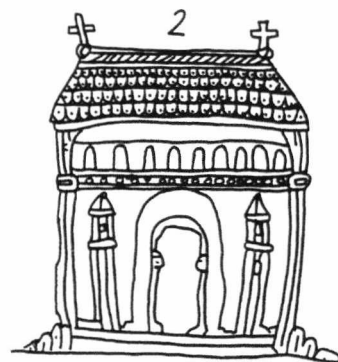
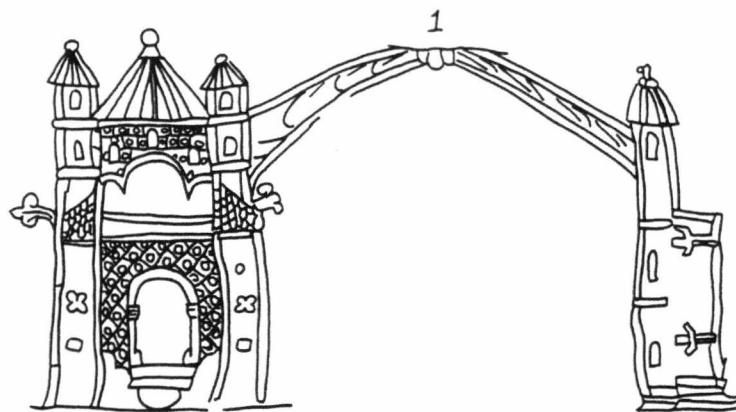

Appendix Illustration: Tapestry Buildings 5, 6, 7, 8 and 9

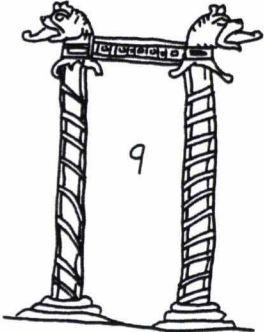
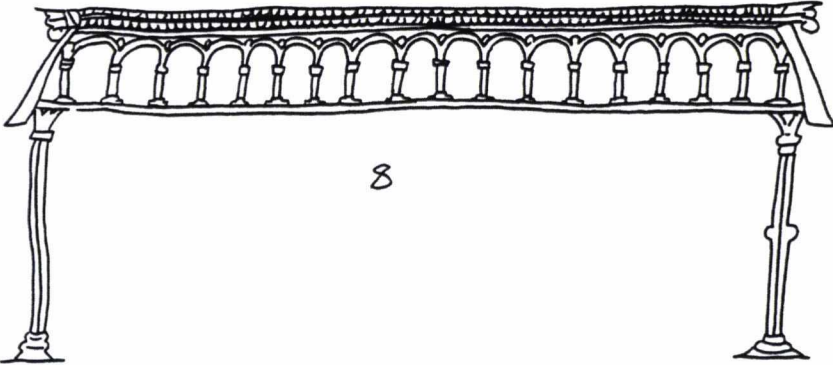
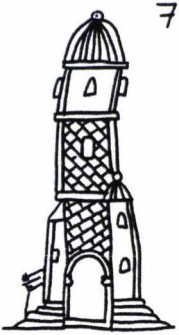
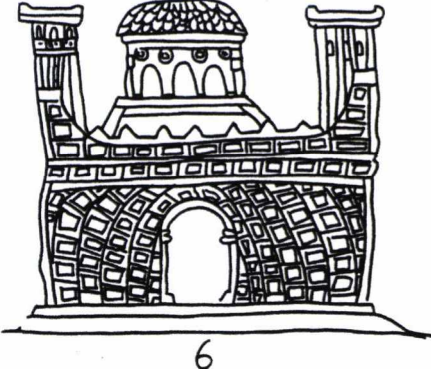
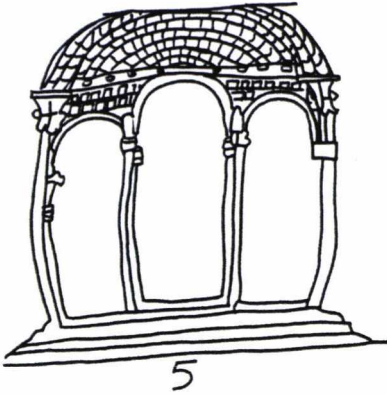

Appendix Illustration: Tapestry Buildings 10, 11, 12, 13, 15 and 16

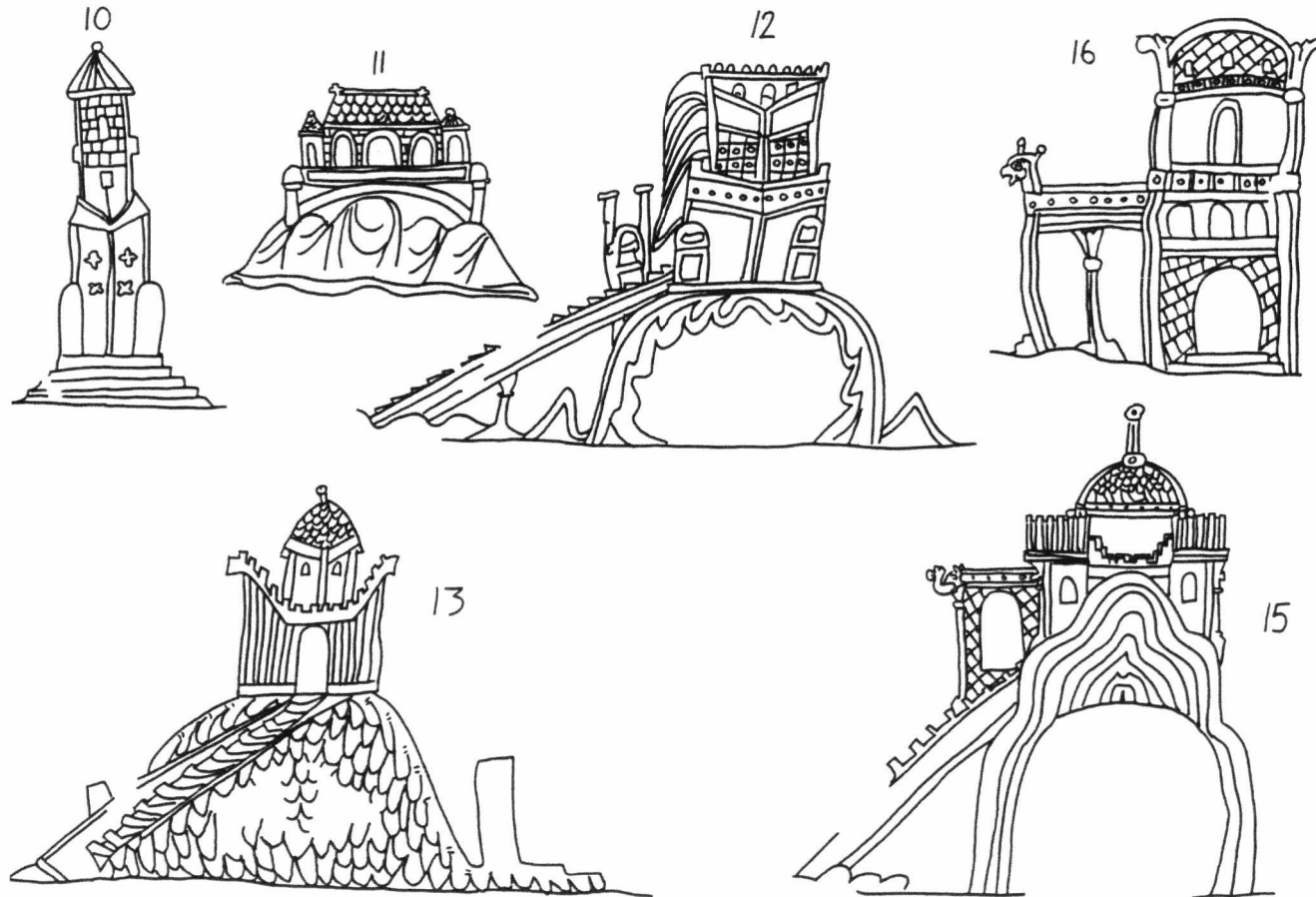

Appendix Illustration: Tapestry Buildings 14, 17, 20 and 28

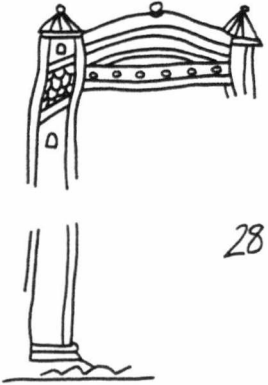
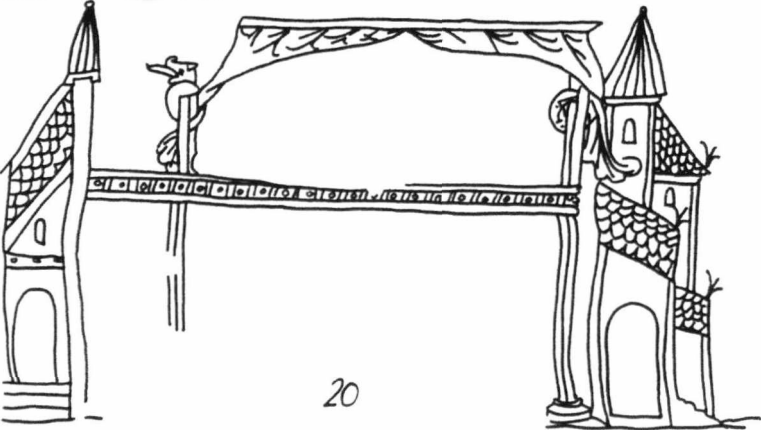
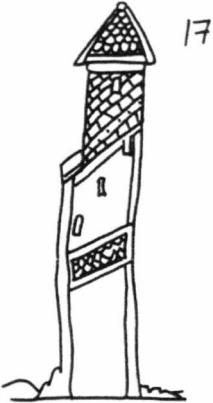
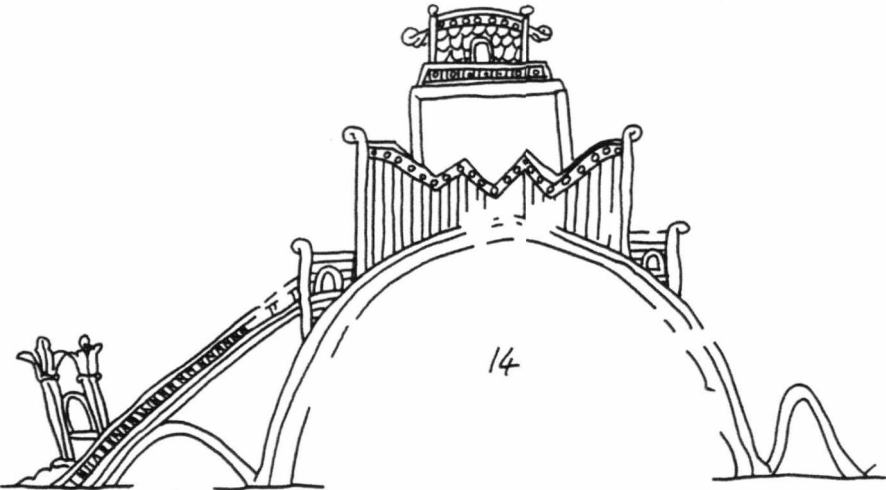

Appendix Illustration: Tapestry Buildings 18, 19, 22, 24 and 27

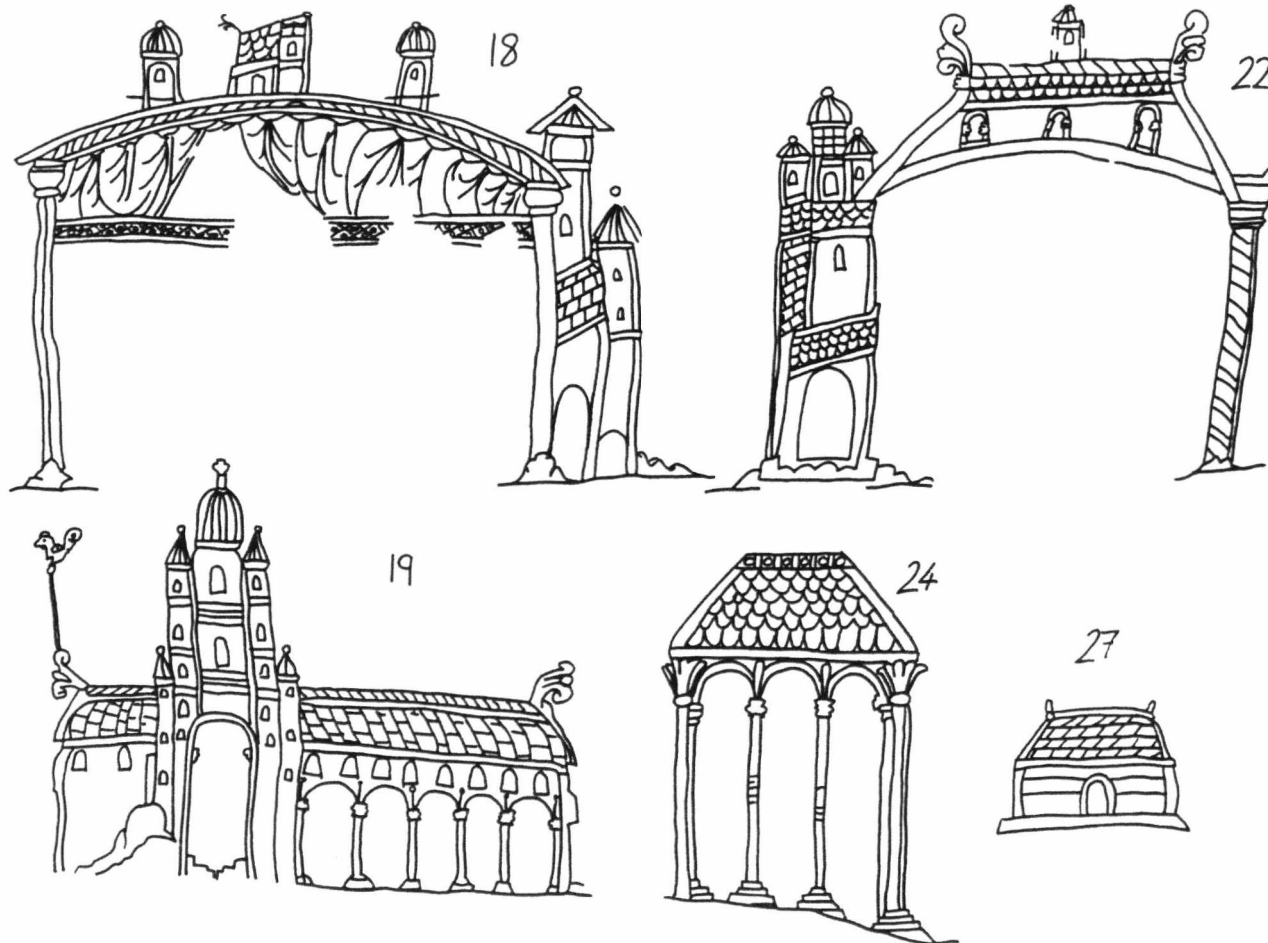

Appendix Illustration: Tapestry Buildings 21, 23, 25 and 26

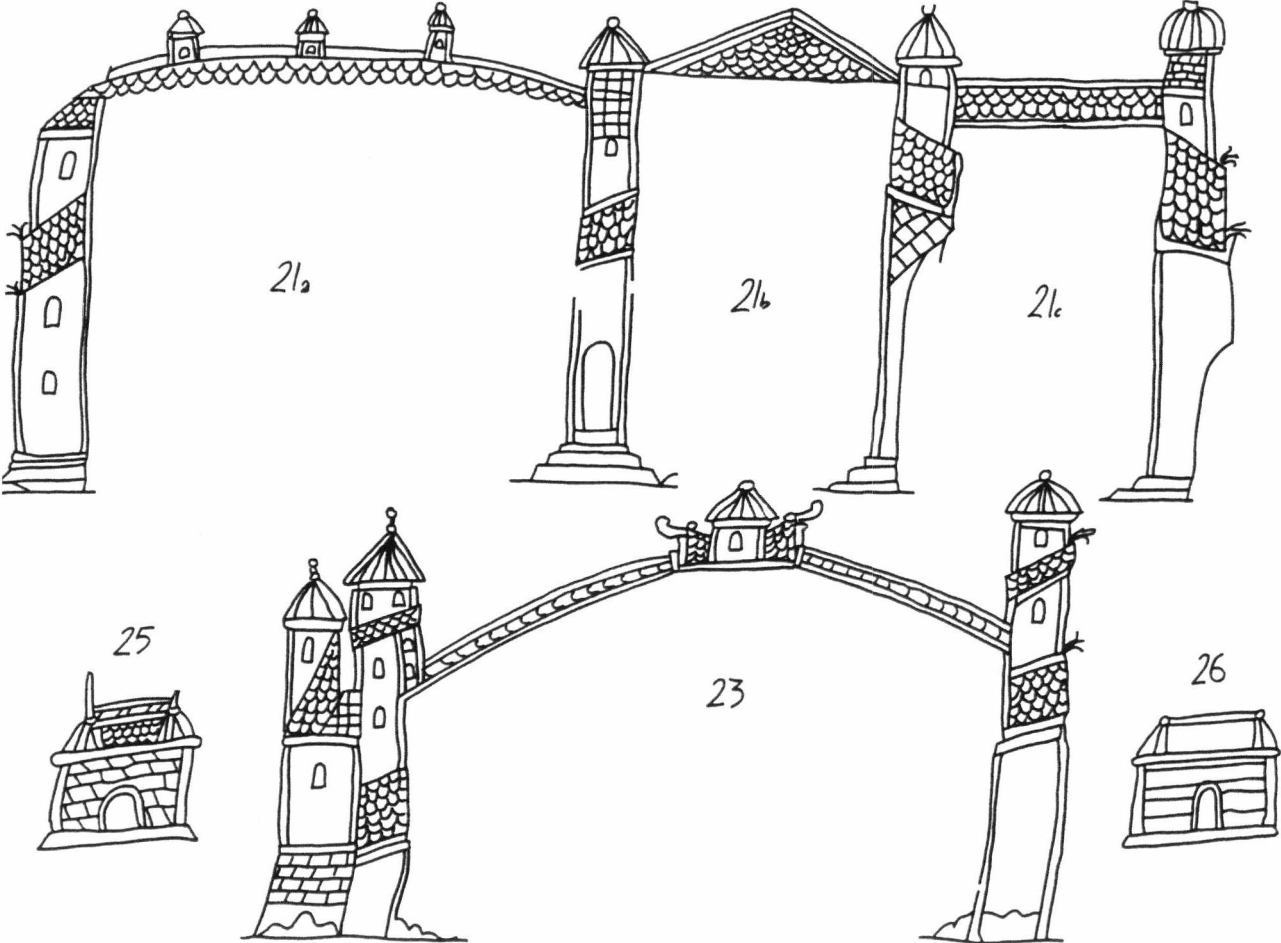

Appendix Illustration: Tapestry Buildings 29, 30, 31, 32 and 33

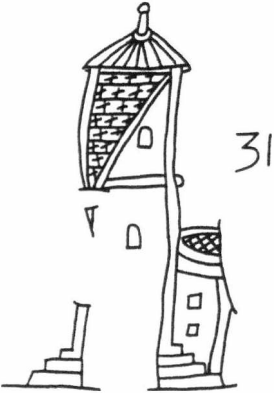
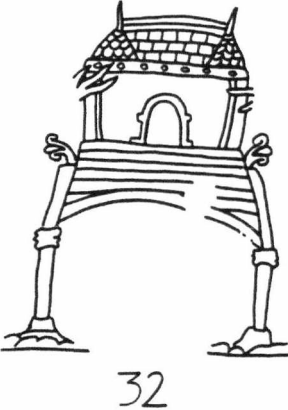
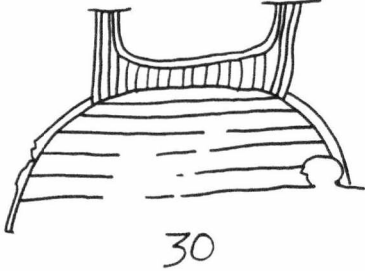
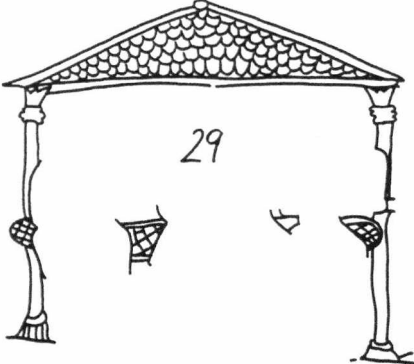

Appendix Illustration: Tapestry Ships 1, 2, 3 and 4

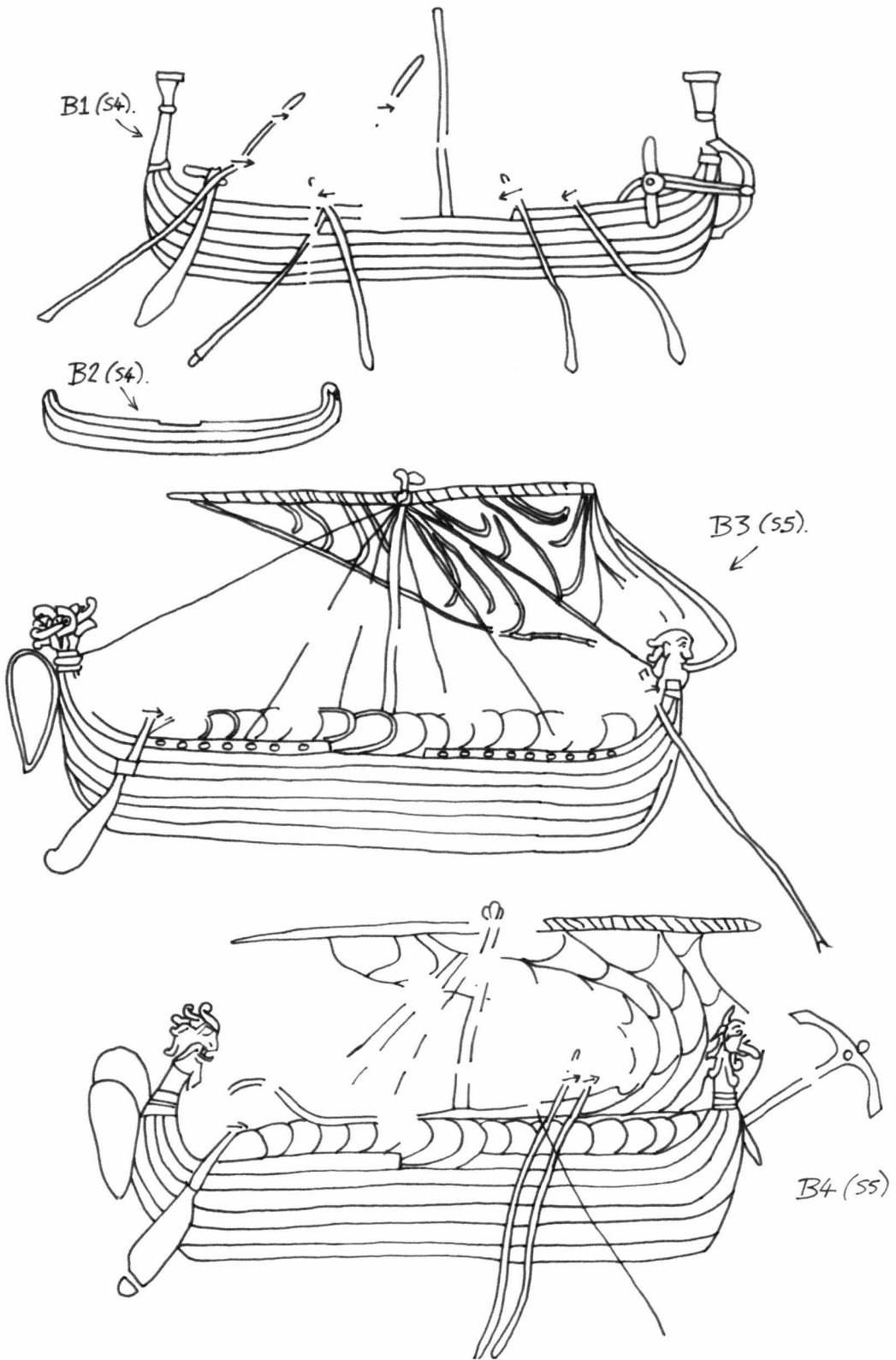

Appendix Illustration: Tapestry Ships 5, 6, 7 and 8

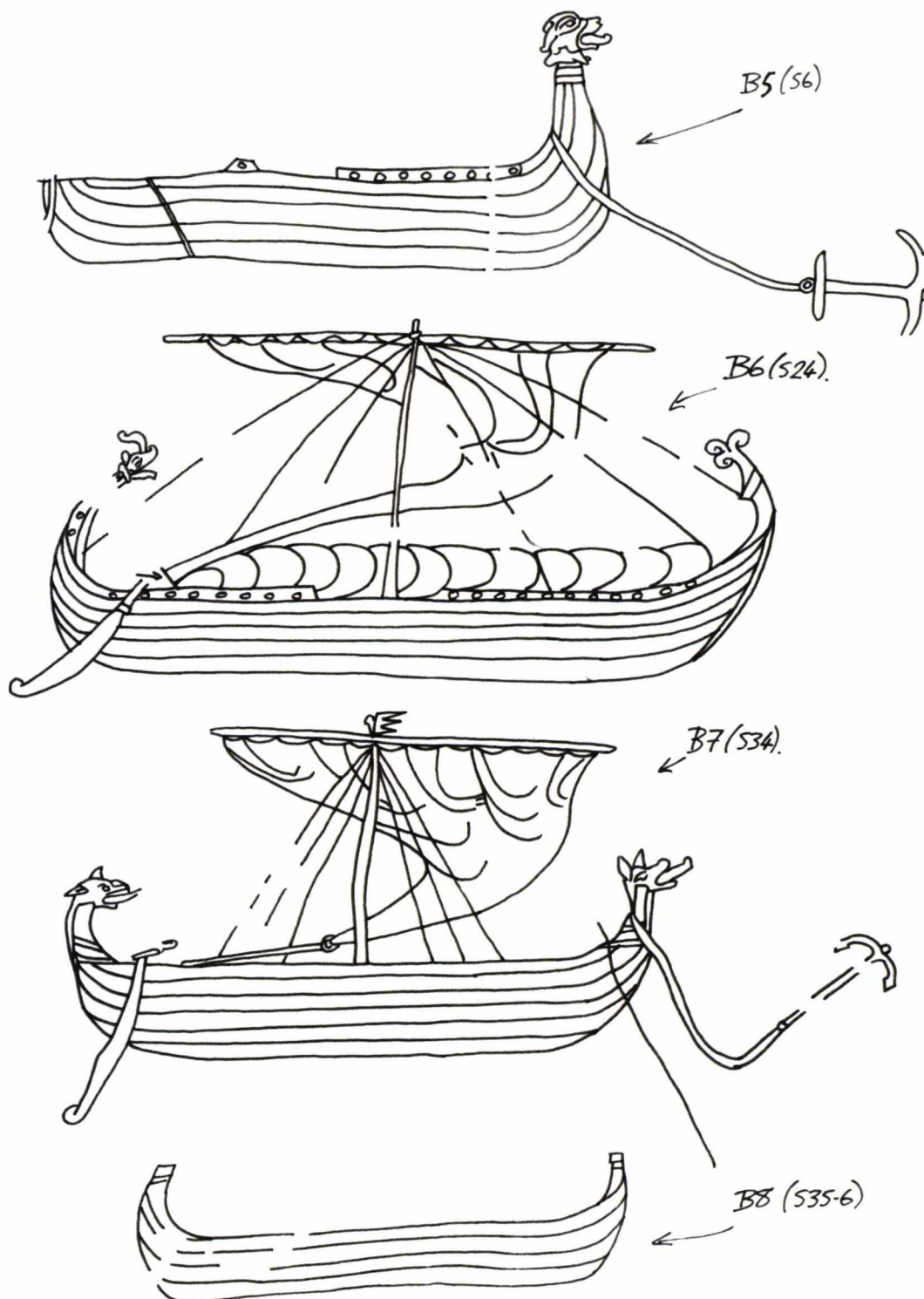

Appendix Illustration: Tapestry Ships 9, 10, 11, 12, 13, 14, 15 and 16

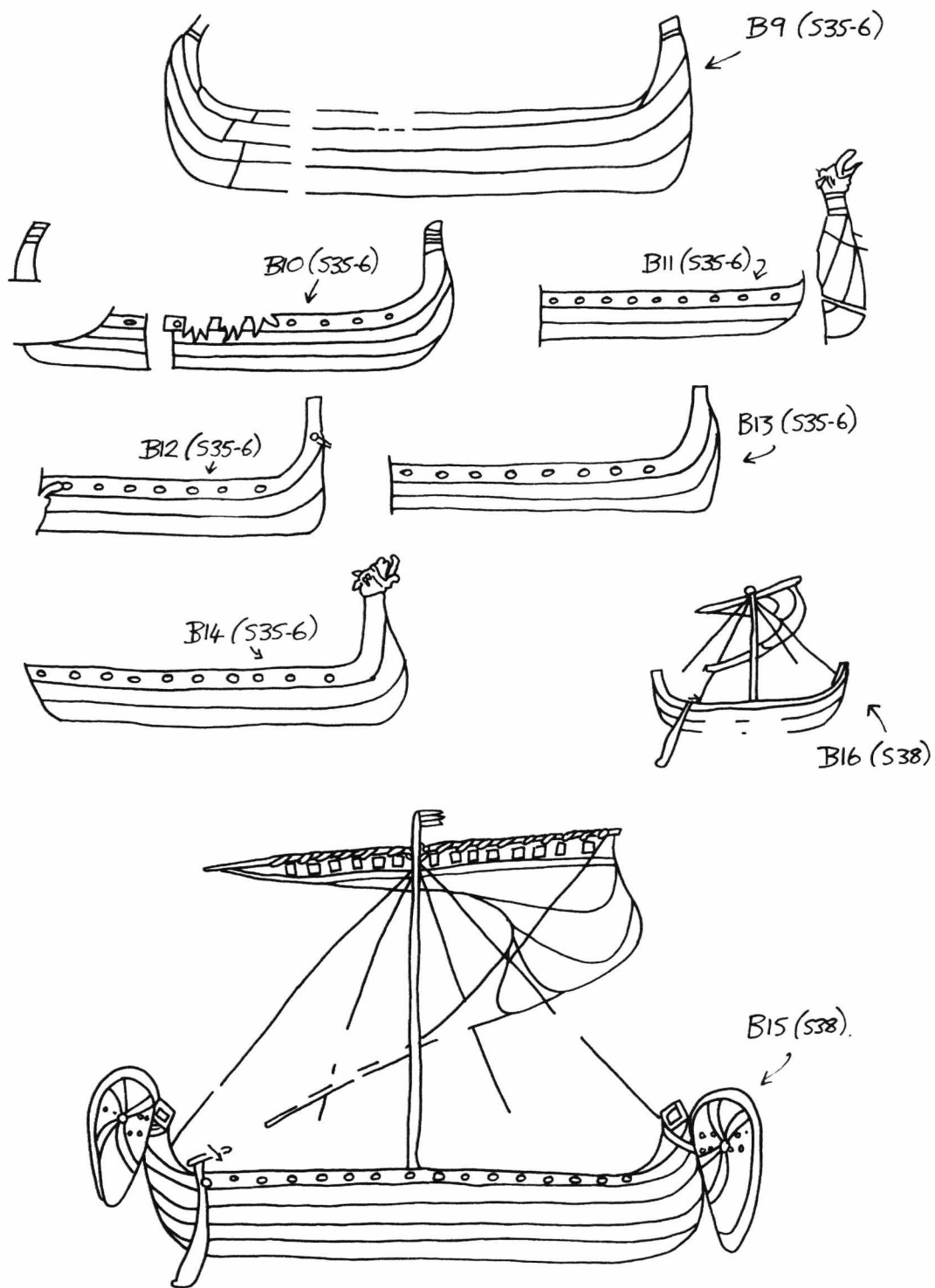

Appendix Illustration: Tapestry Ships 17, 18, 19, 20 and 21

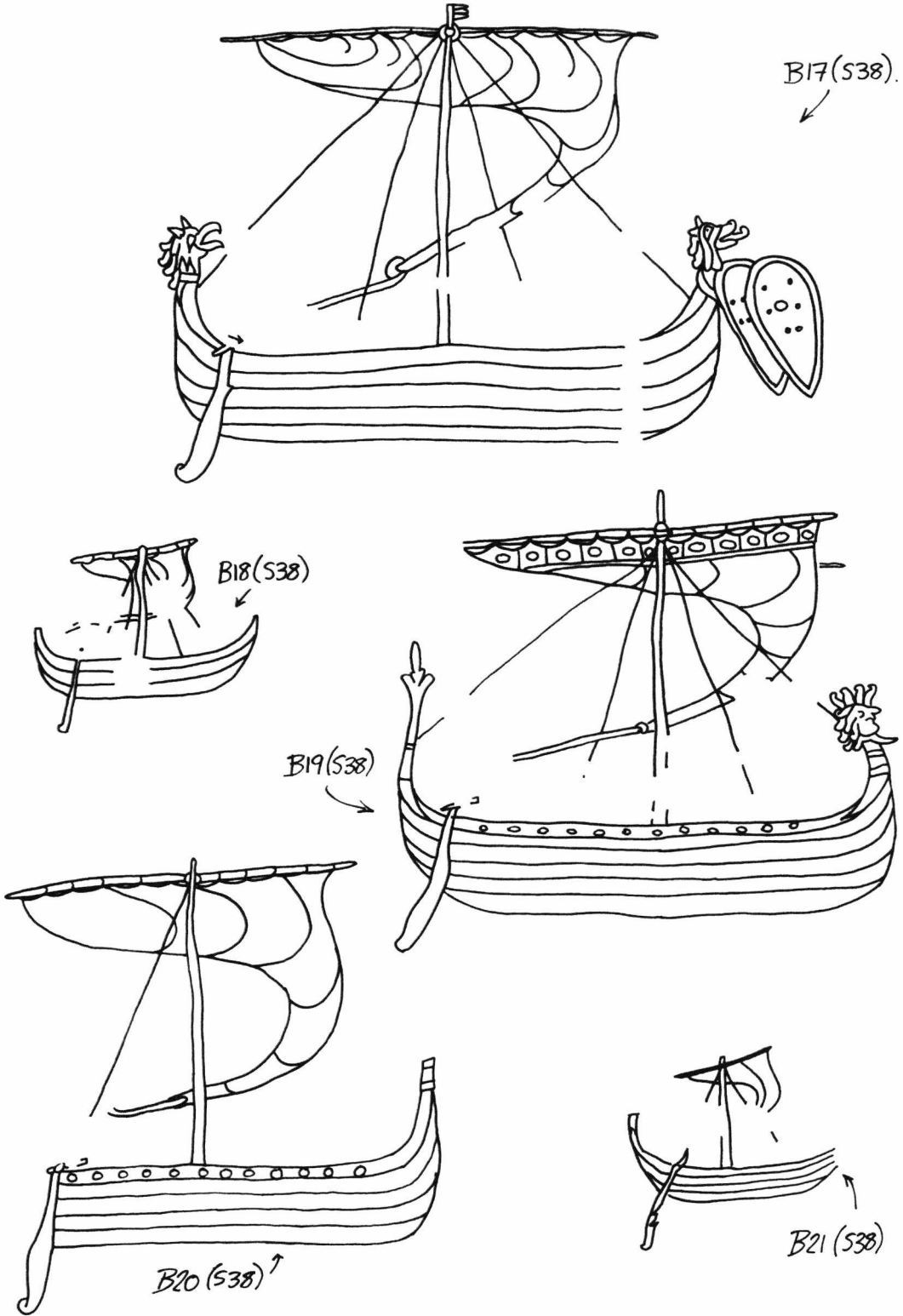

Appendix Illustration: Tapestry Ships 22, 23, 24, 25 and 27

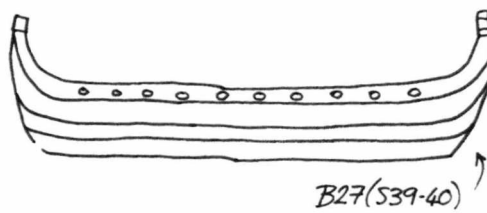
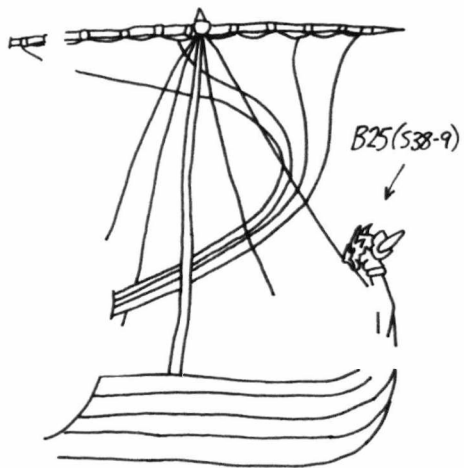
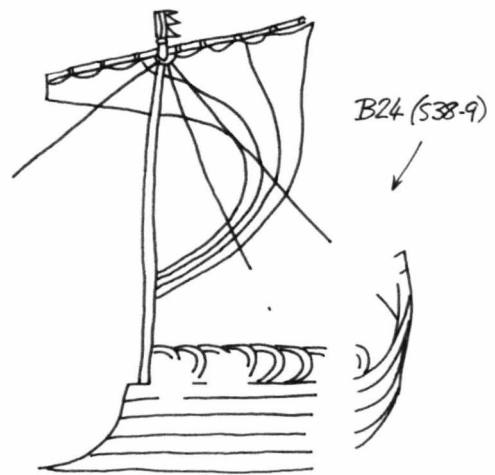
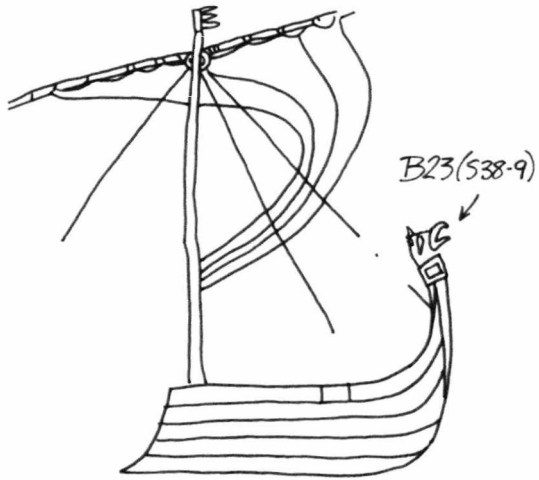
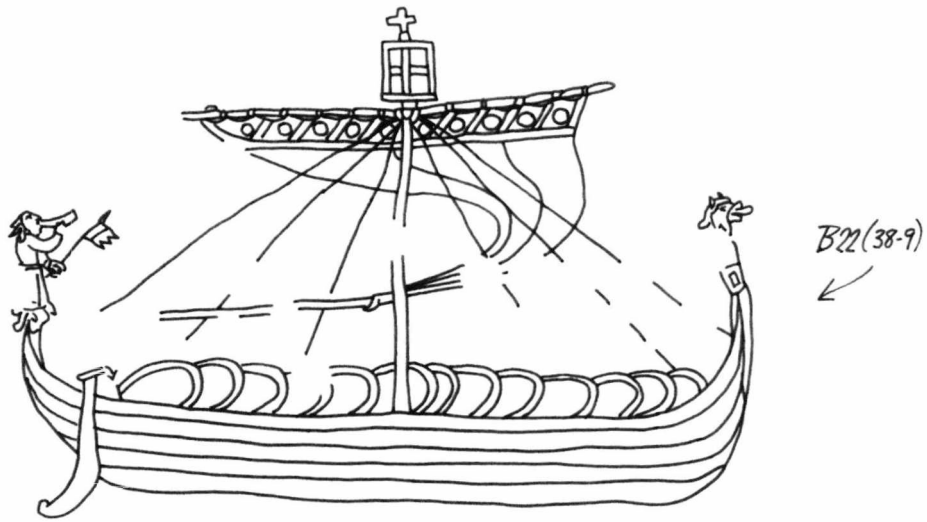

Appendix Illustration: Tapestry Ships 26, 28, 29, 30, 31, 32, 33, 34, 35, 36 and 37

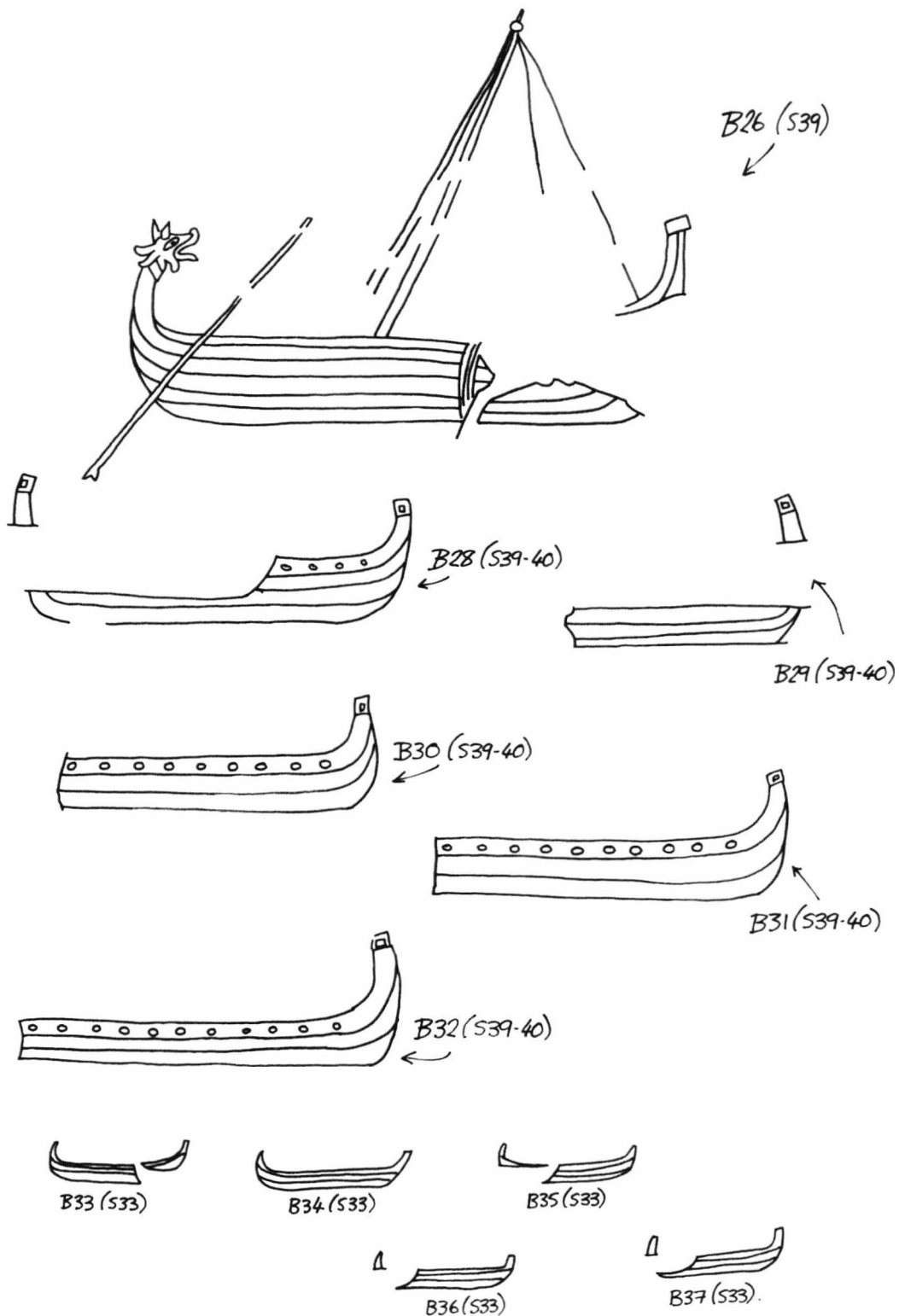

Appendix Illustration: Tapestry Ships – Stem Decoration

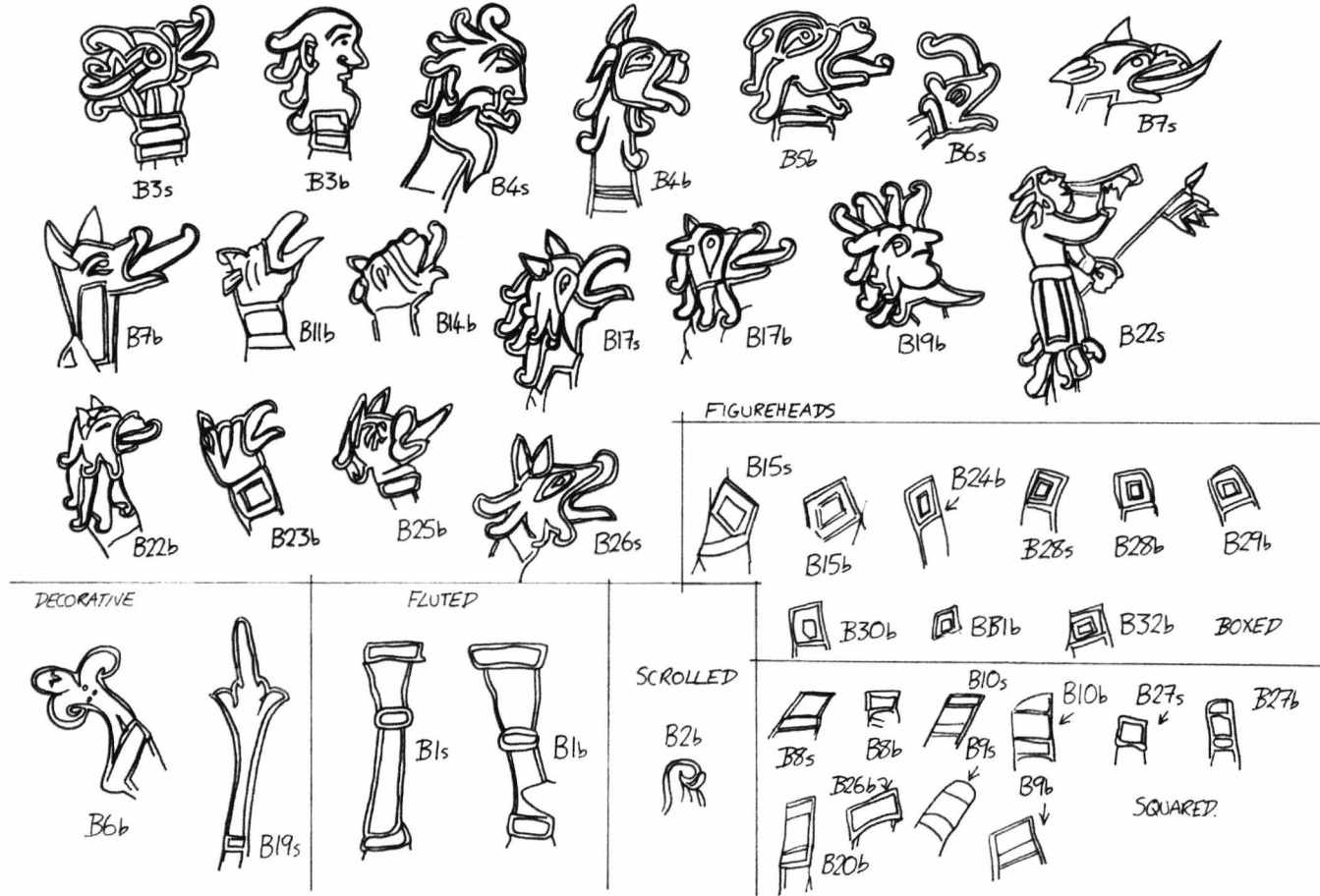

Appendix Illustration: Tapestry Ships – Sails

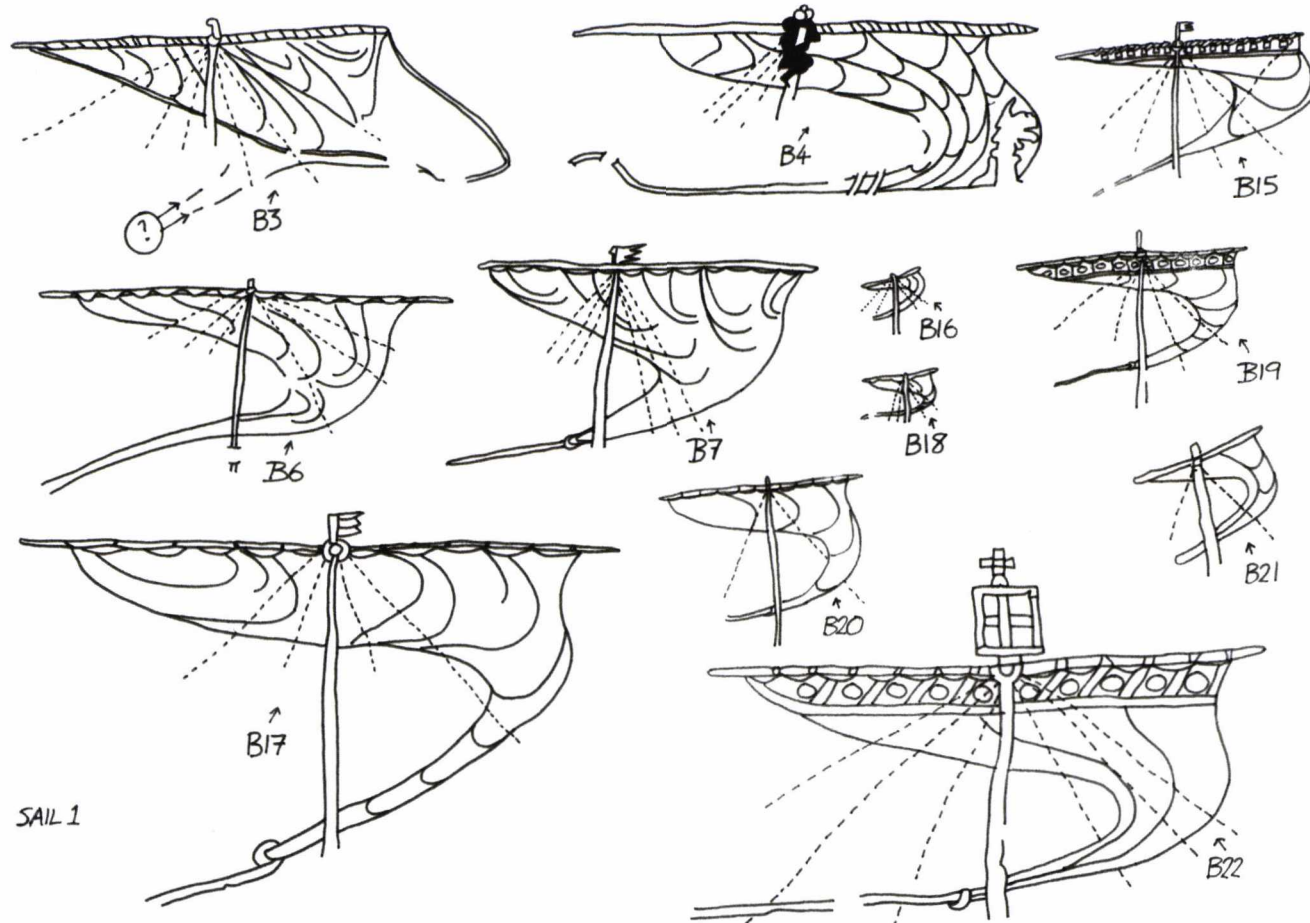

Appendix Illustration: Tapestry Ships – Sails and Rudders

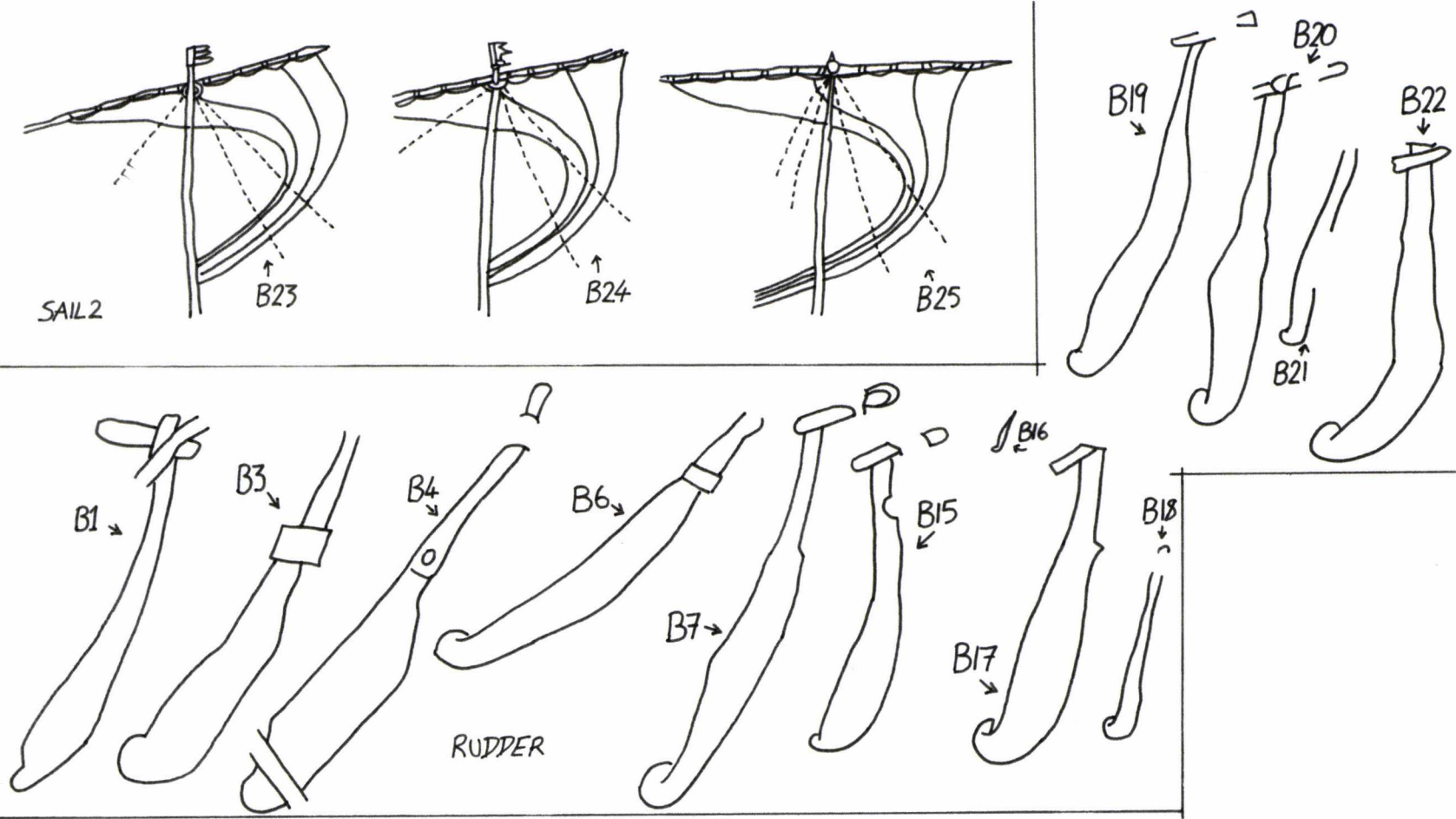

Appendix Illustration: Tapestry Trees 1, 2 and 3

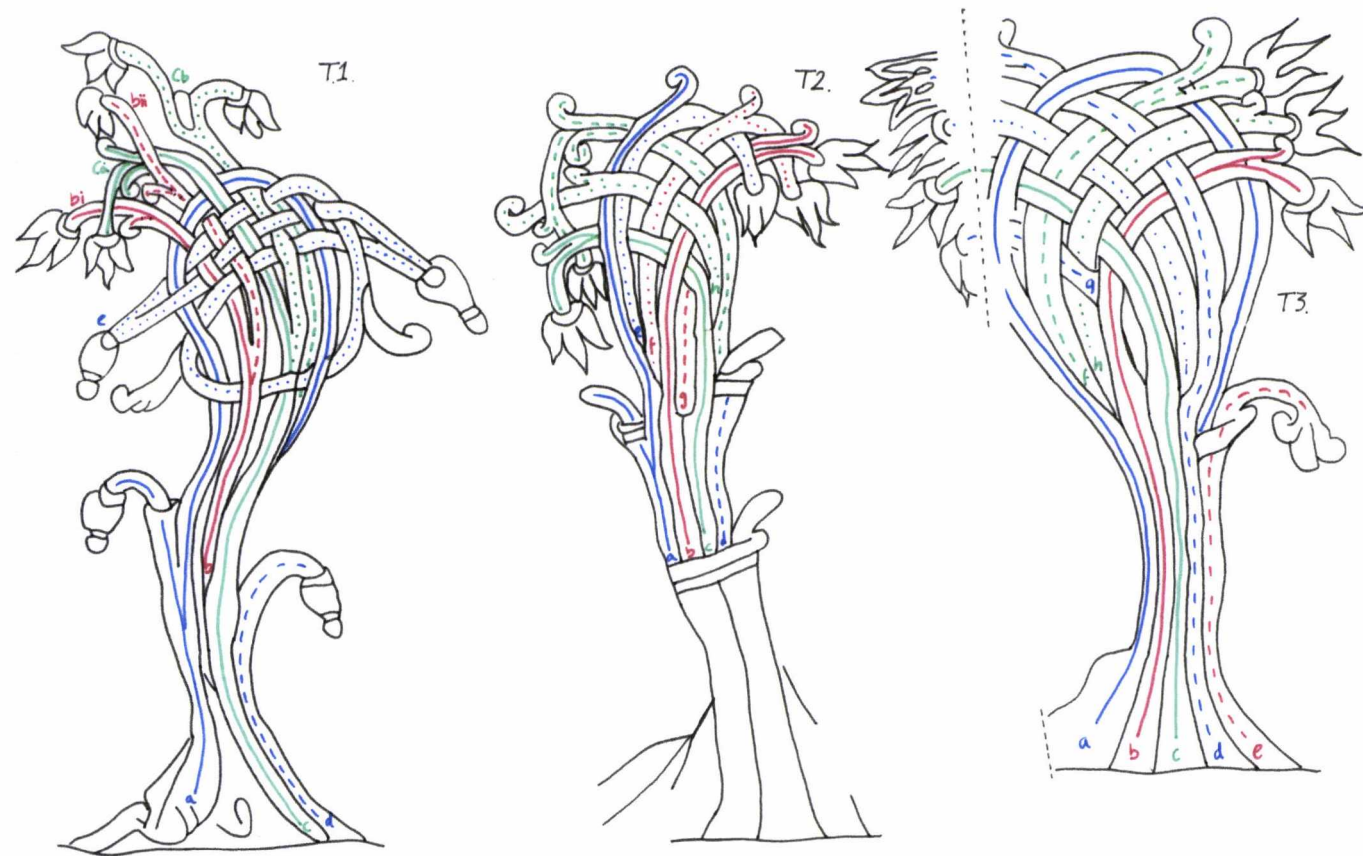

Appendix Illustration: Tapestry Trees 4, 5 and 6

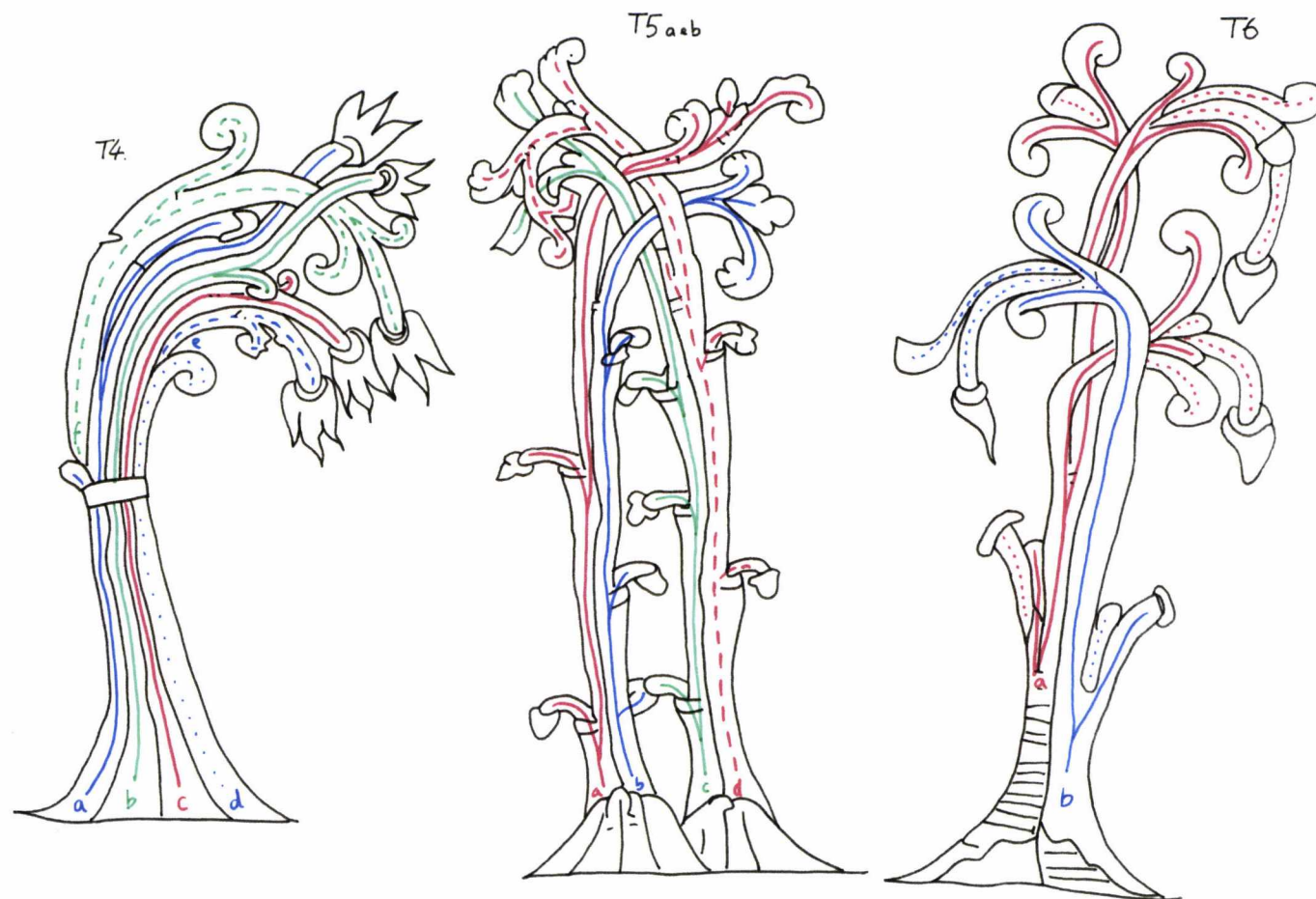

Appendix Illustration: Tapestry Trees 7, 8, 9 and 10

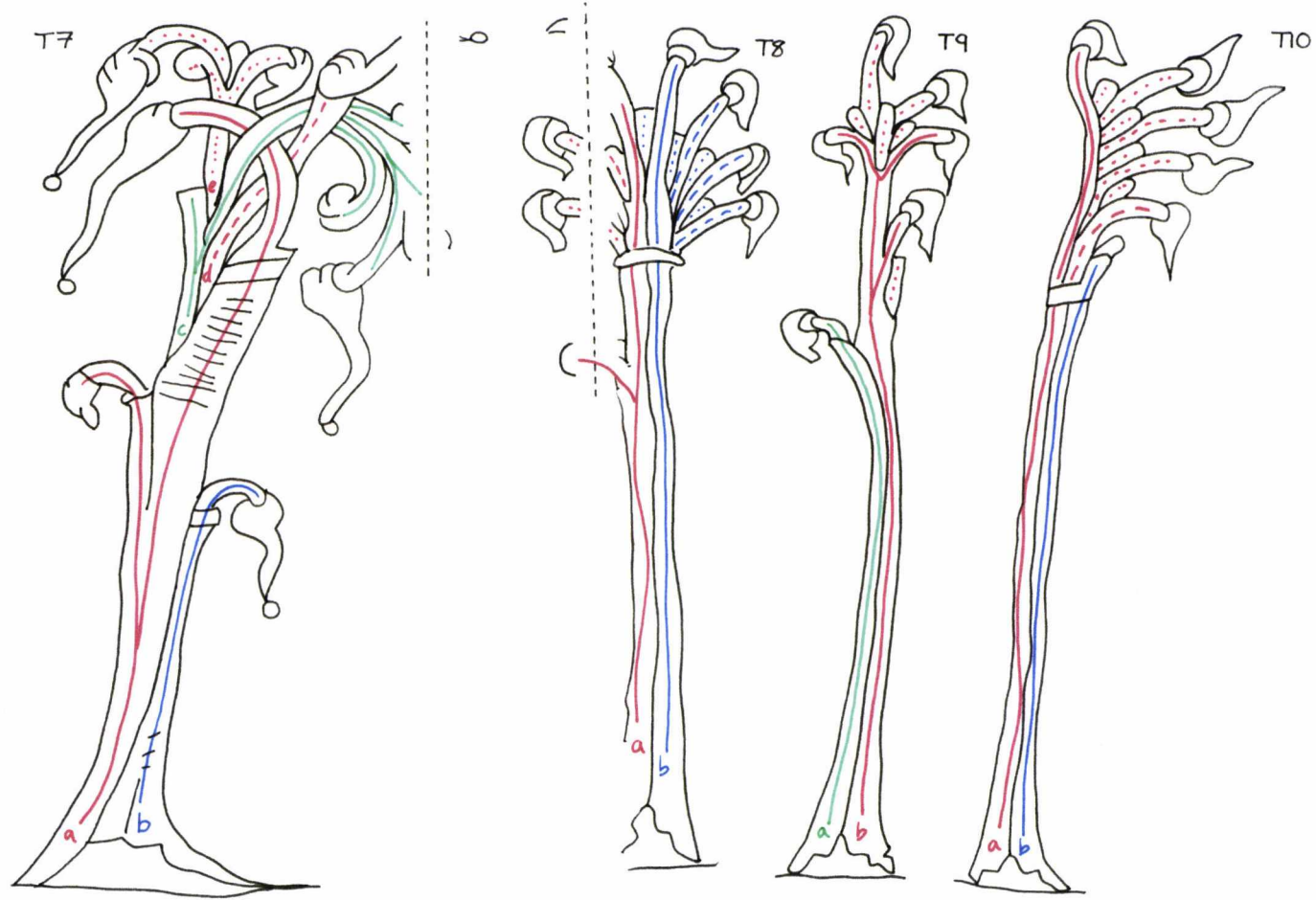

Appendix Illustration: Tapestry Trees 11, 12, 13 and 14

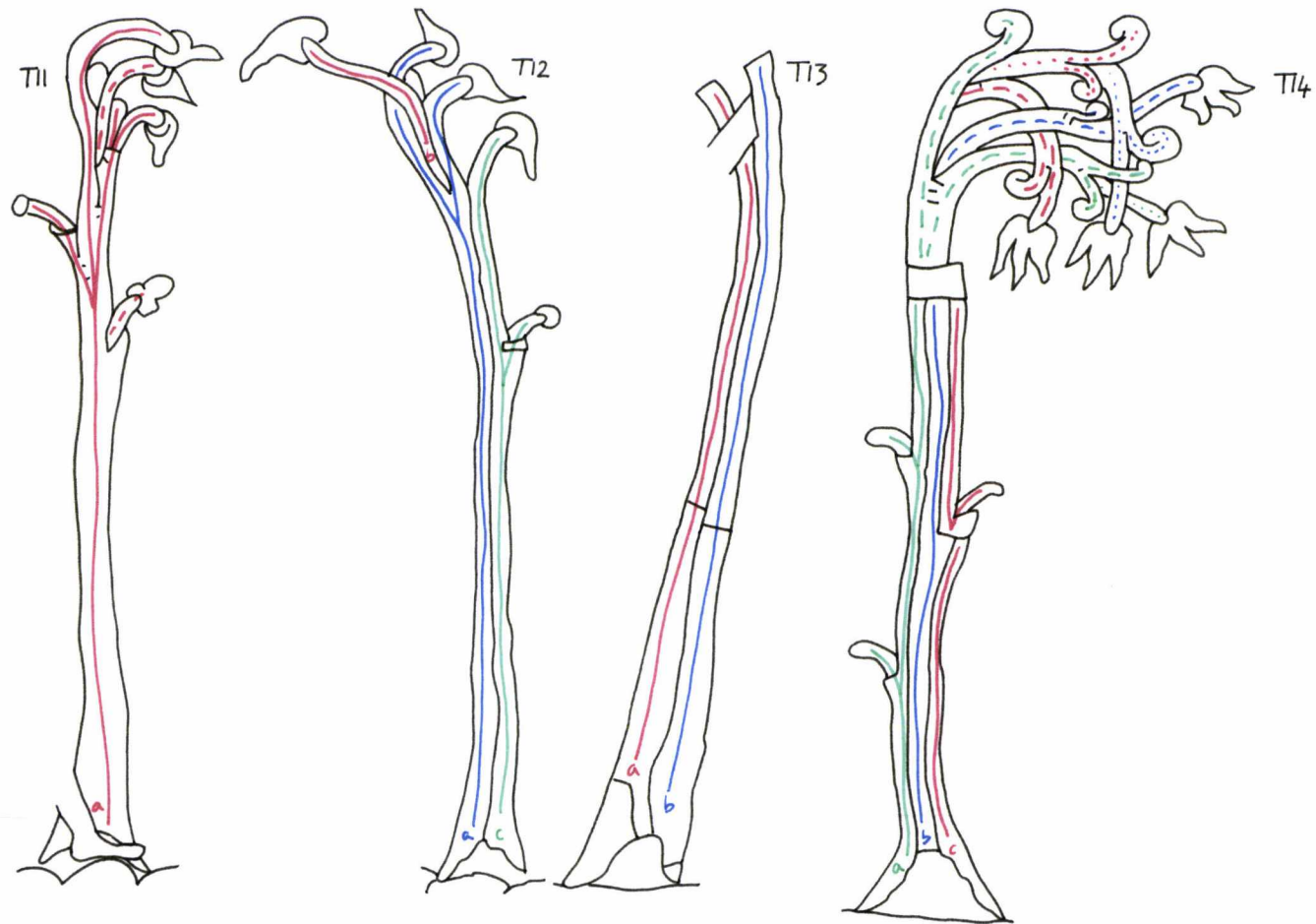

Appendix Illustration: Tapestry Trees 15, 16, 17 and 18

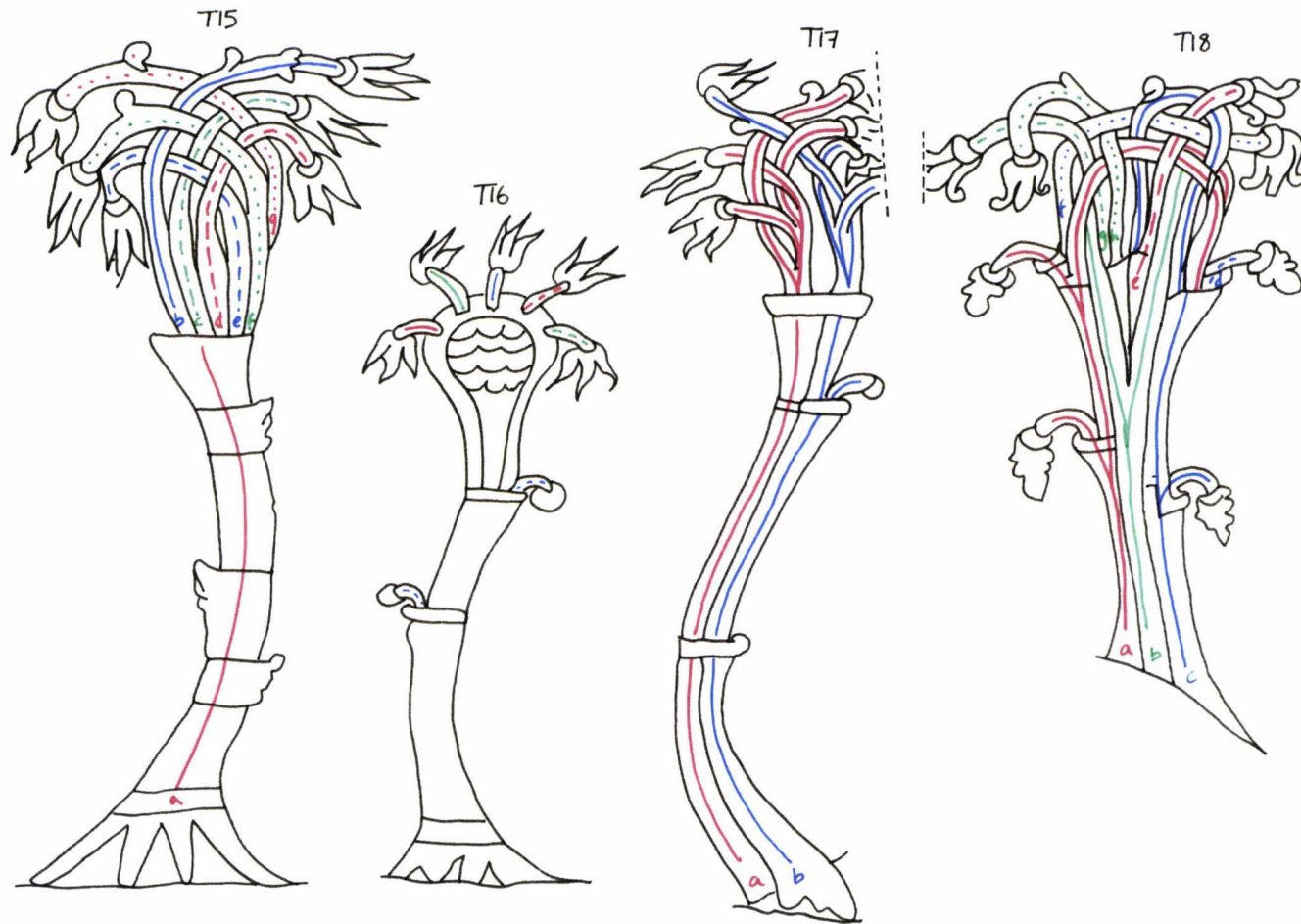

Appendix Illustration: Tapestry Trees 19, 20, 21 and 22

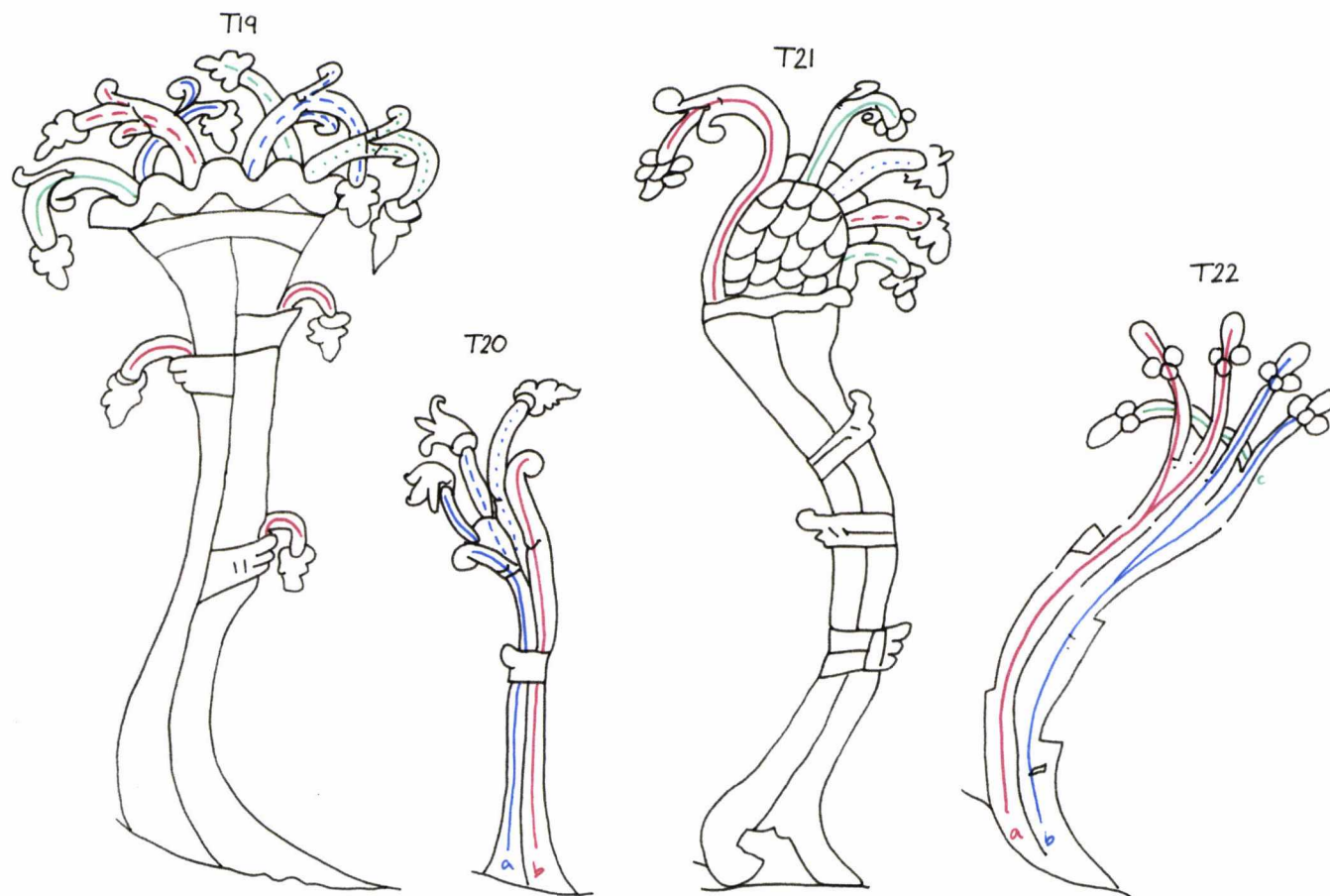

Appendix Illustration: Tapestry Tree 23

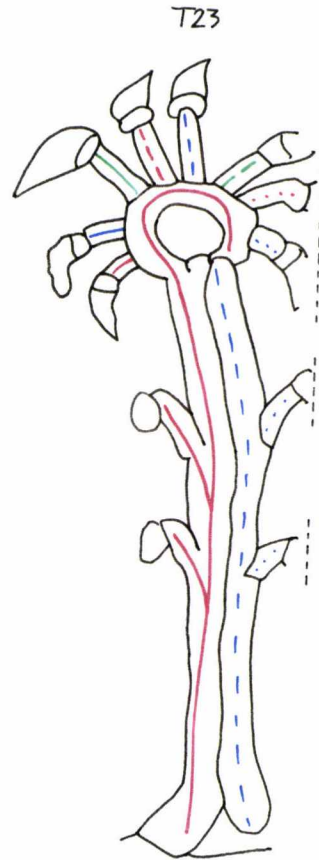

FACSIMILE OF THE BAYEUX TAPESTRY

Key to Numbers:

Section divisions (shown as vertical line through Tapestry)

Scenes

Figures (characters)

Buildings

Ships

Animals (birds and beasts)

Vegetation

00 (orange)

S.00 (black)

00 (black)

B00 (purple)

S00 (blue)

A00 (red)

V00 (green)



S.1.

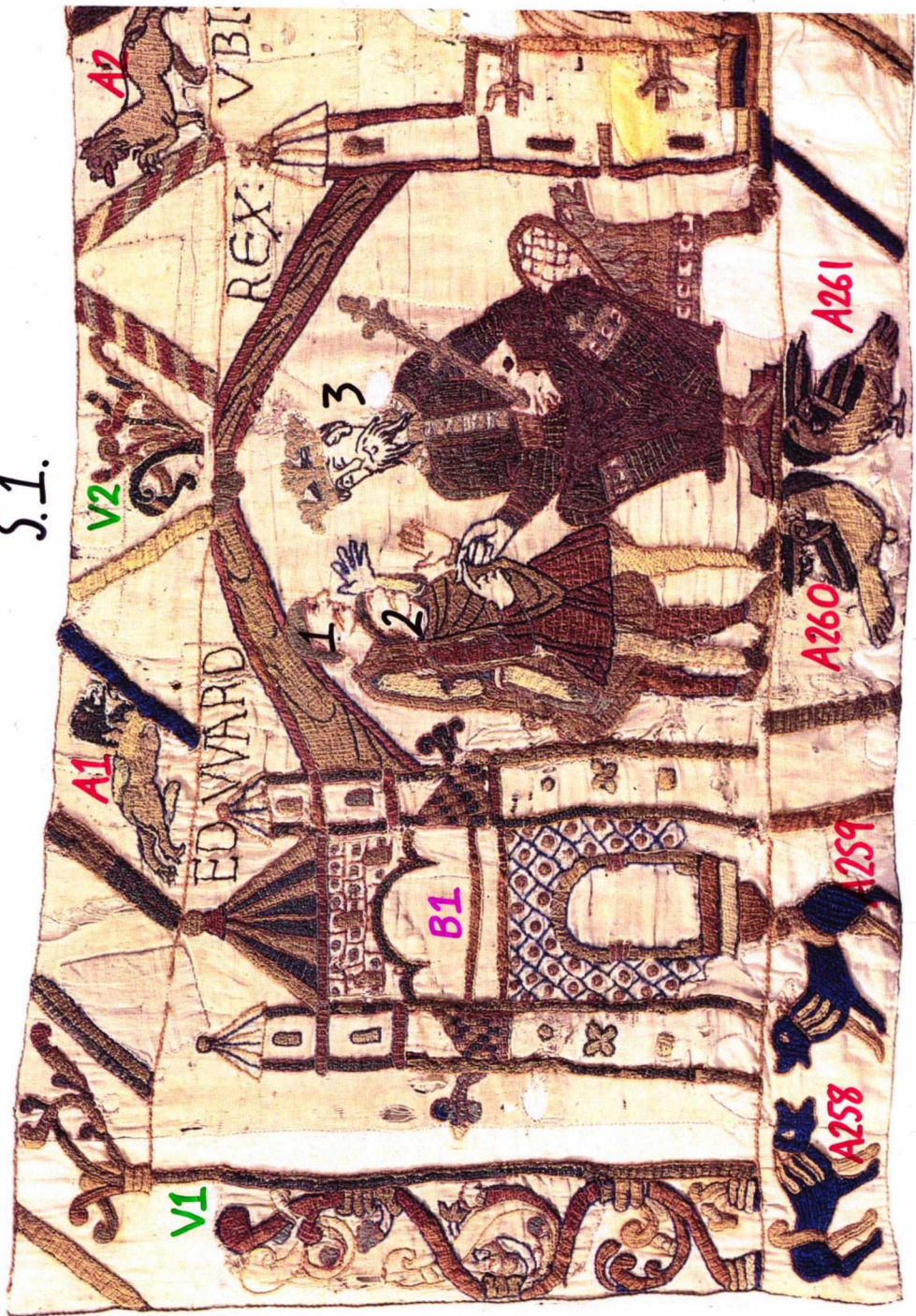

S.2.



S.3.



A17

A8

V7

A9

V8

A10

V9

A11

T1

B2

A540

A541

A543

A542

A544

IO

II

A266

A267

A268

A269

A270

A271

S.4.



S1



S.5.



S.6.

S.7.



V135 V236



V238

V237

V236

S.8.

A27



V258

S.9.

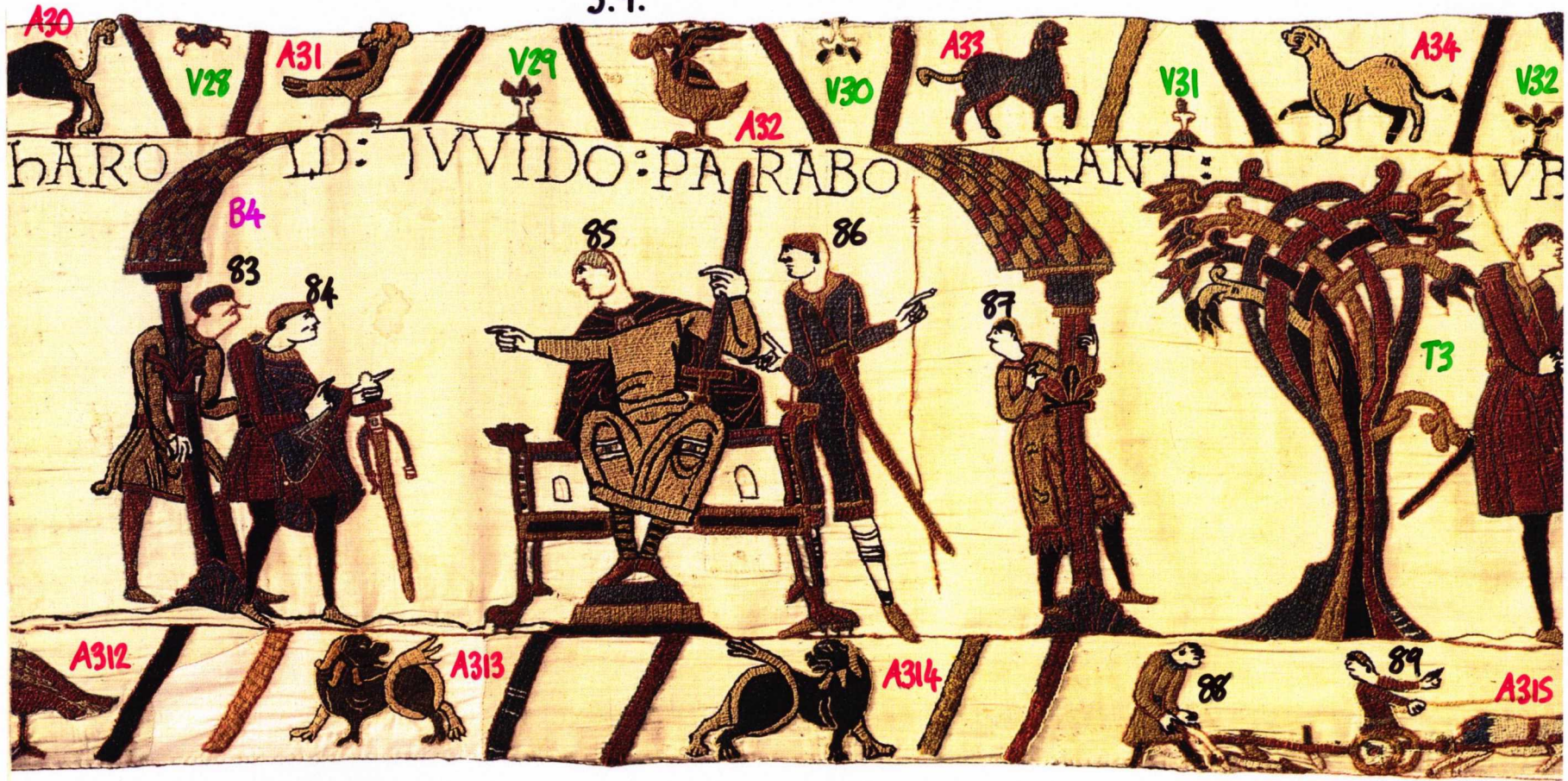

S.10.



I: NVNTII: VVILLELMI: 94: DVCCIS: VENERVNT: ADVVIDO: NĒ

TIVROLD

A35 V33 A36 V34 A37 V35 A38 V36
A315 91 92 A316 93 94 95 A317 A318 A319 V239

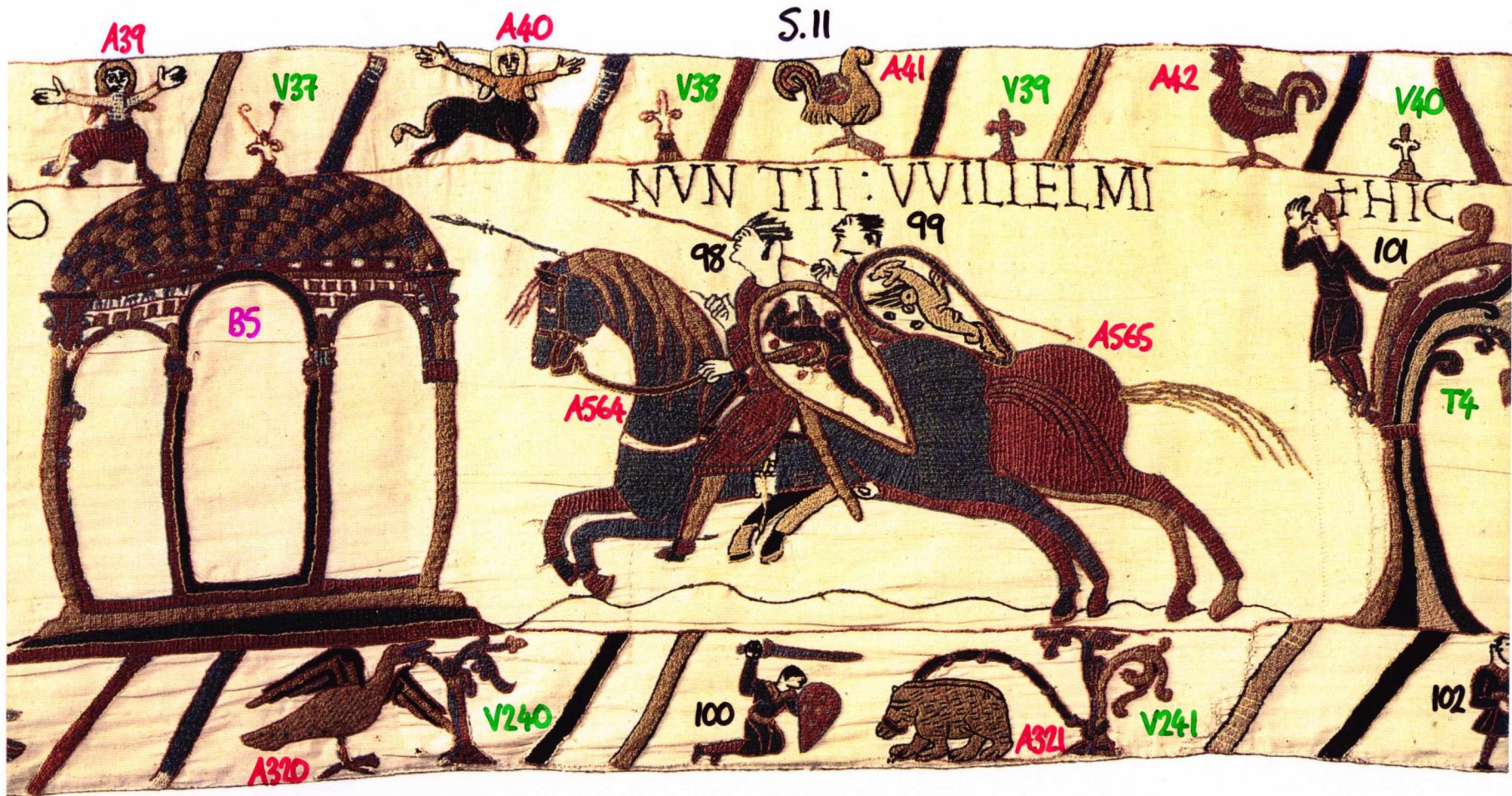

S.12



T4

102

A43

A44

V41

A45

A46

V42

A47

V43

VENI: NVNTIYS: ADWIL
103 GELMVM DV CEM

HIC: WIDO:
109

106

105

104

108

107

110

104

105

106

107

108

109

110

111

112

113

114

115

116

117

118

119

120

121

122

123

124

125

126

127

B6

AS67

AS66

A327

A326

V242

V243

A327

A328

A329

A330

A323

A325

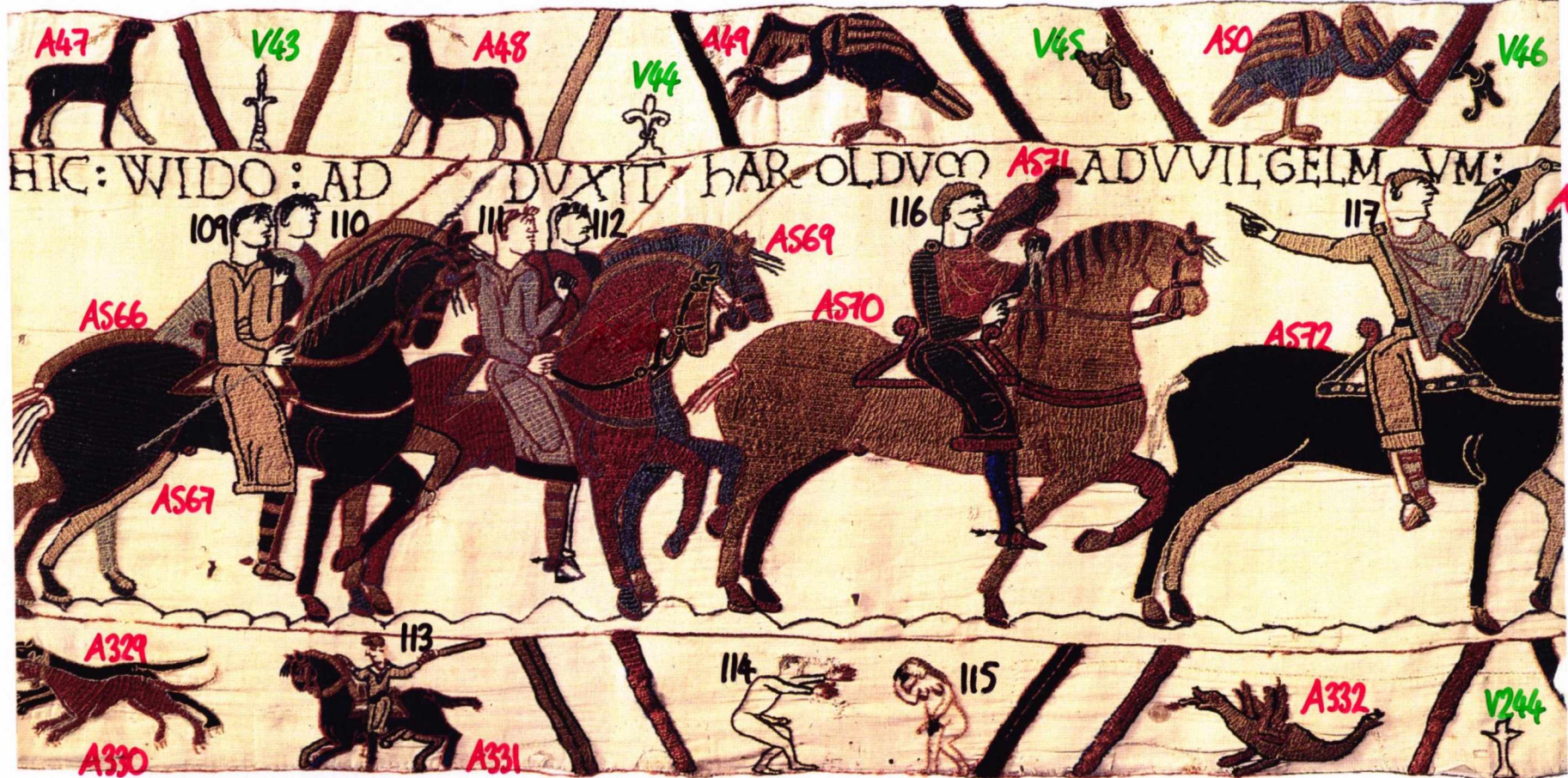

HIC: WIDO: AD DVXIT HAR. OLDVCO ADVVILGELM VM:

109 110 111 112 113 114 115 116 117

A566

A567

A569

A570

A571

A572

A573

A329

A330

113

A331

114

115

A332

V244

A47

V43

A48

V44

A49

V45

A50

V46

1 2 ASS AS6



1 2

S.14

A60

A59

V50

A58

A57

V49

A56

HIC DVX: WILGELM: CVM HAROLDO: VENIT: AD PA

122

A581

124

125

126

127

B8

LATIV SVV

127

B7

A582

A583

A584

A338

A339

V251

A337

V250

A336

V248

V249



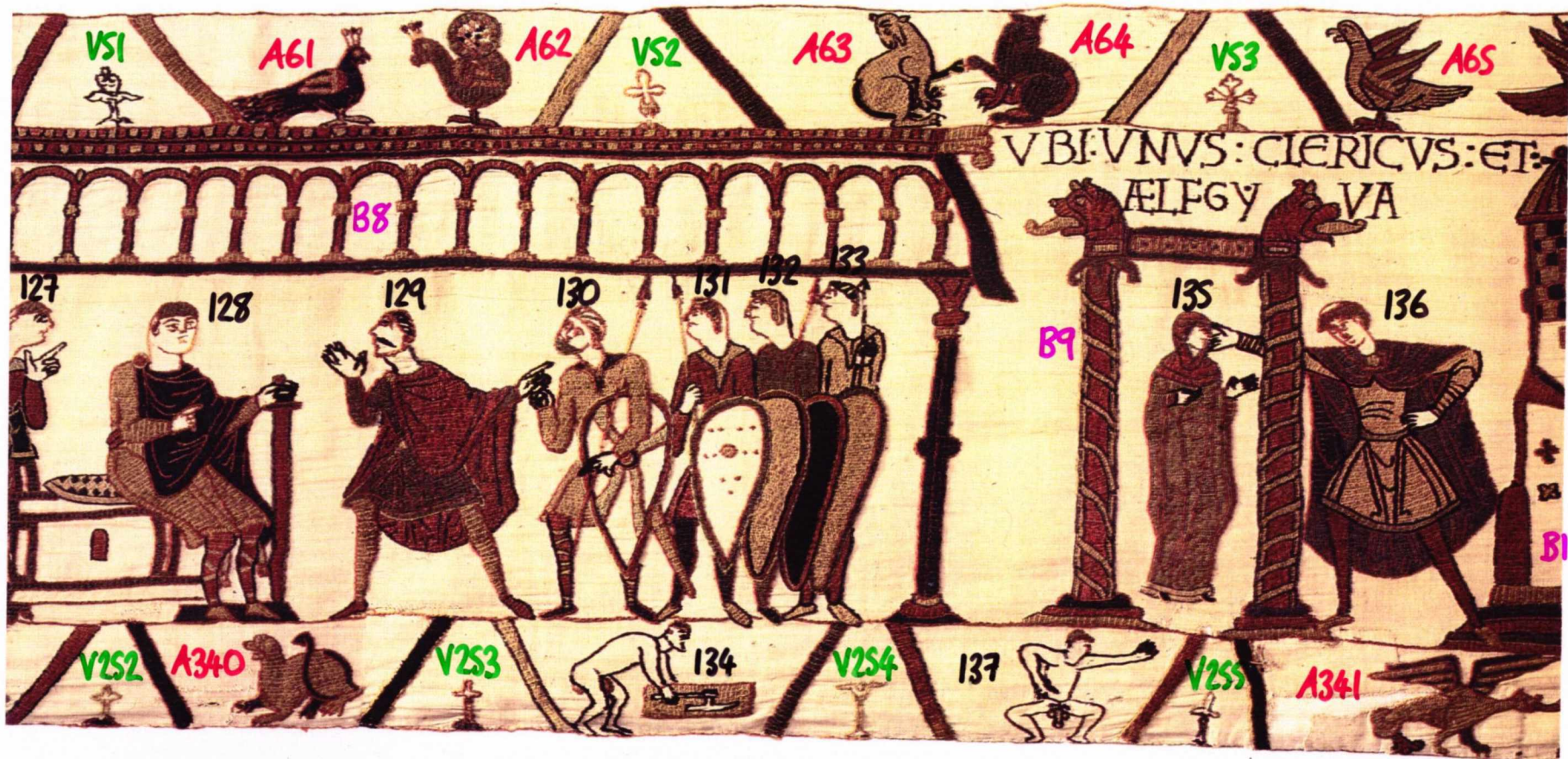

V51

A61

A62

V52

A63

A64

V53

A65

A66

B8

127

128

129

130

131

132

133

B9

135

136

B10

V252

A340

V253

134

V254

137

V255

A341



HIC VVILLE M: DVX: ET EXERCITVS: EIVS: VE NERVNT: ADM

B10

A585

138

139

A586

140

141

142

A589

A588

A590

A344

A342

A343

A345

V260

A346

V256

V257

V258

V259

S.17

146

B11



A72

V87

143

A590

144

A591

A592

147

148

149

A593

150

A347

V261

V262

A348

A349

A351

A352

V263

A350

A353

A73

V58

V59

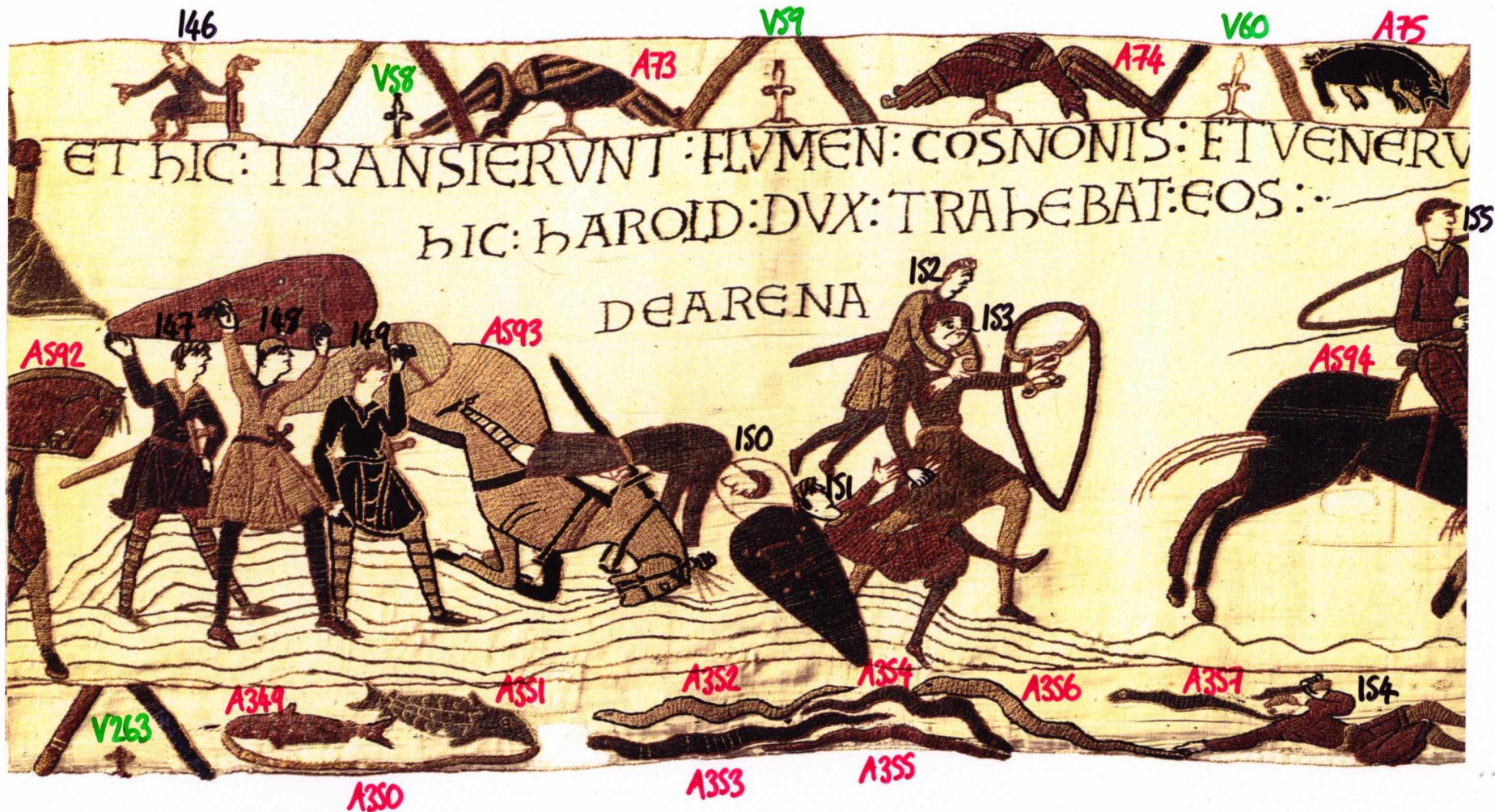

S.18

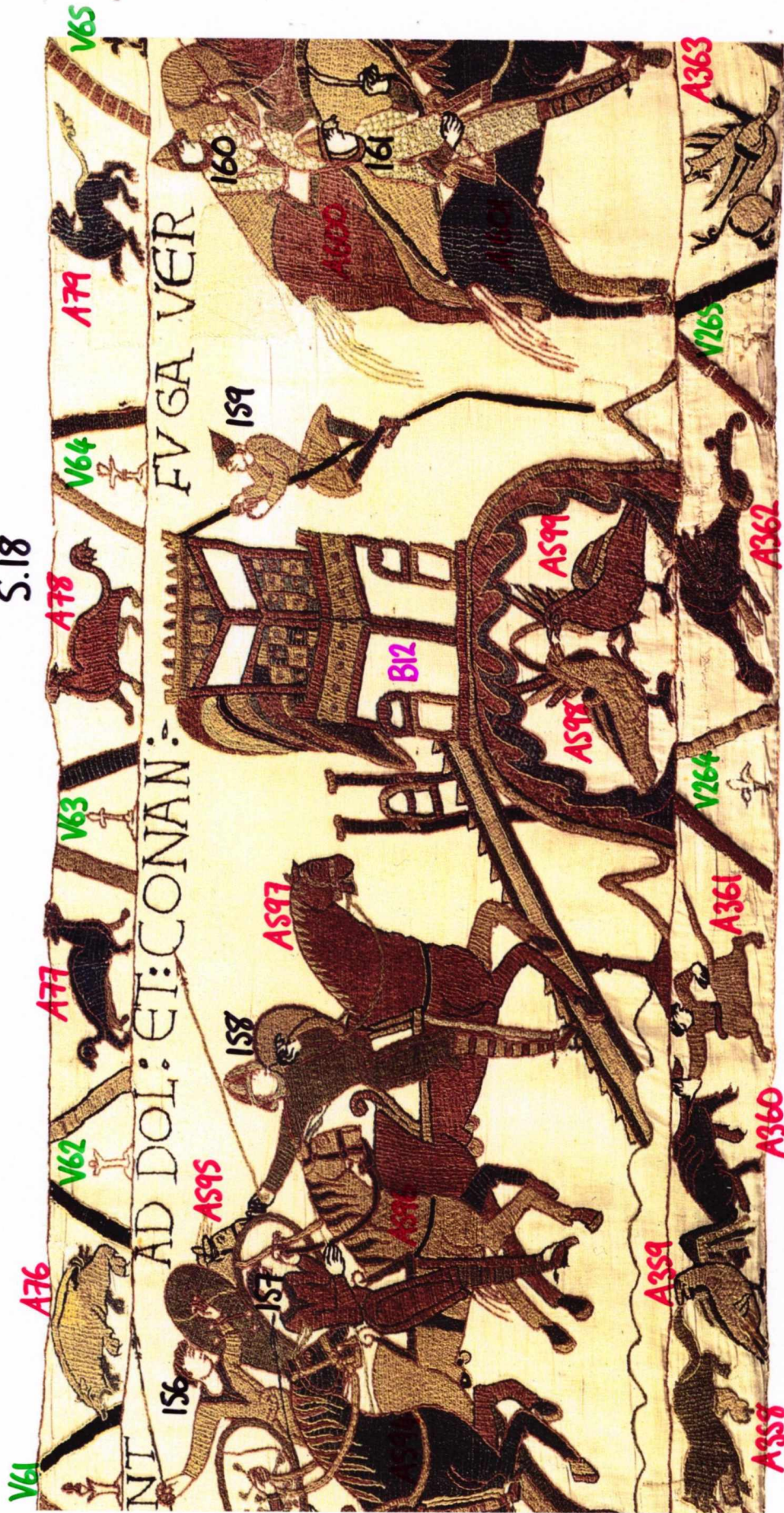



S.19



A83

V68

A82

V69

A84

V70

A85

V71

WILLELM:DVICIS:PVG

NANT:CONTRA

164

A606

165

166

167

A608

A609

B14

V269

V270

A366

A367

A368

V272

A369

V273

V274

V27A

S.20

B14

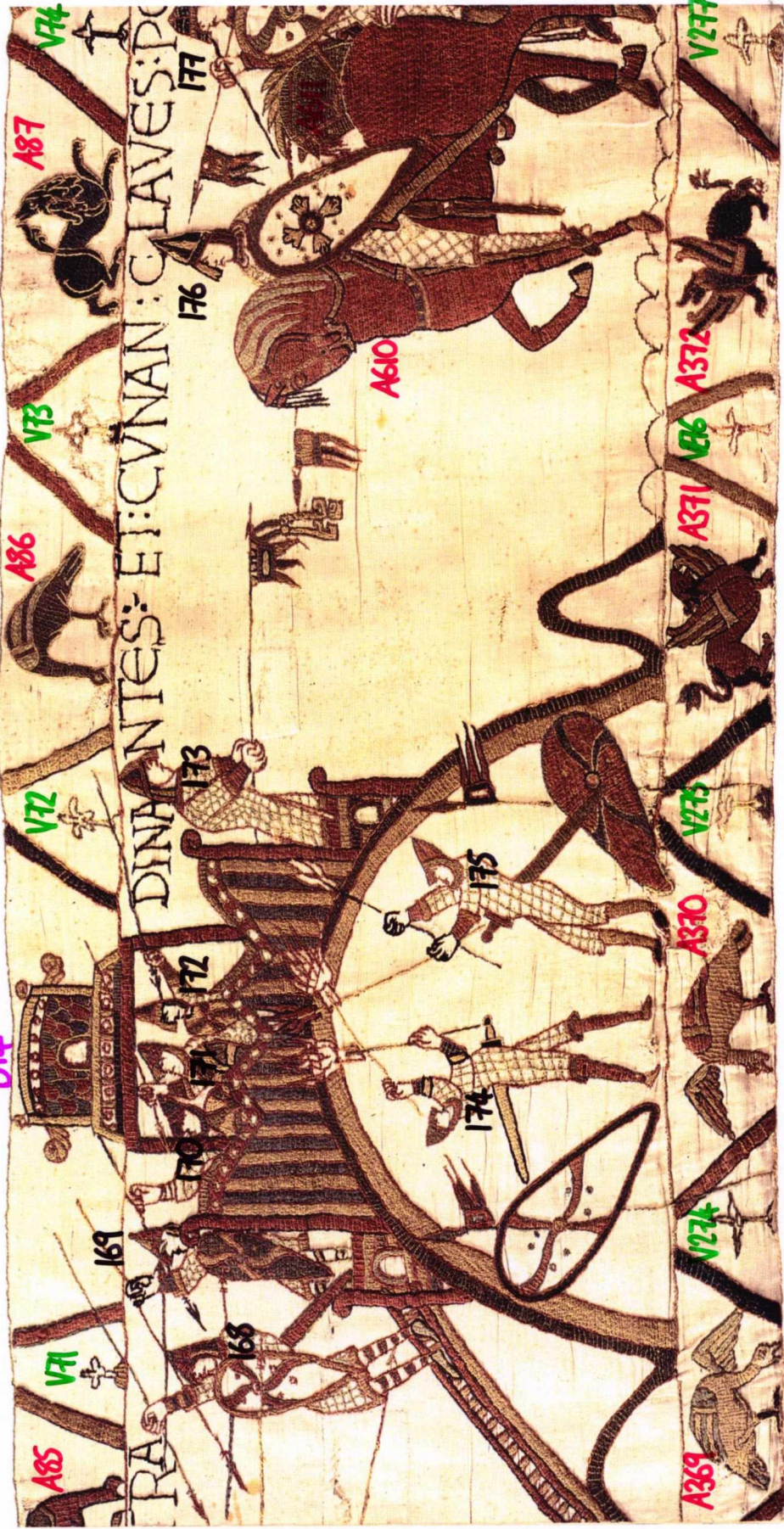

S.21



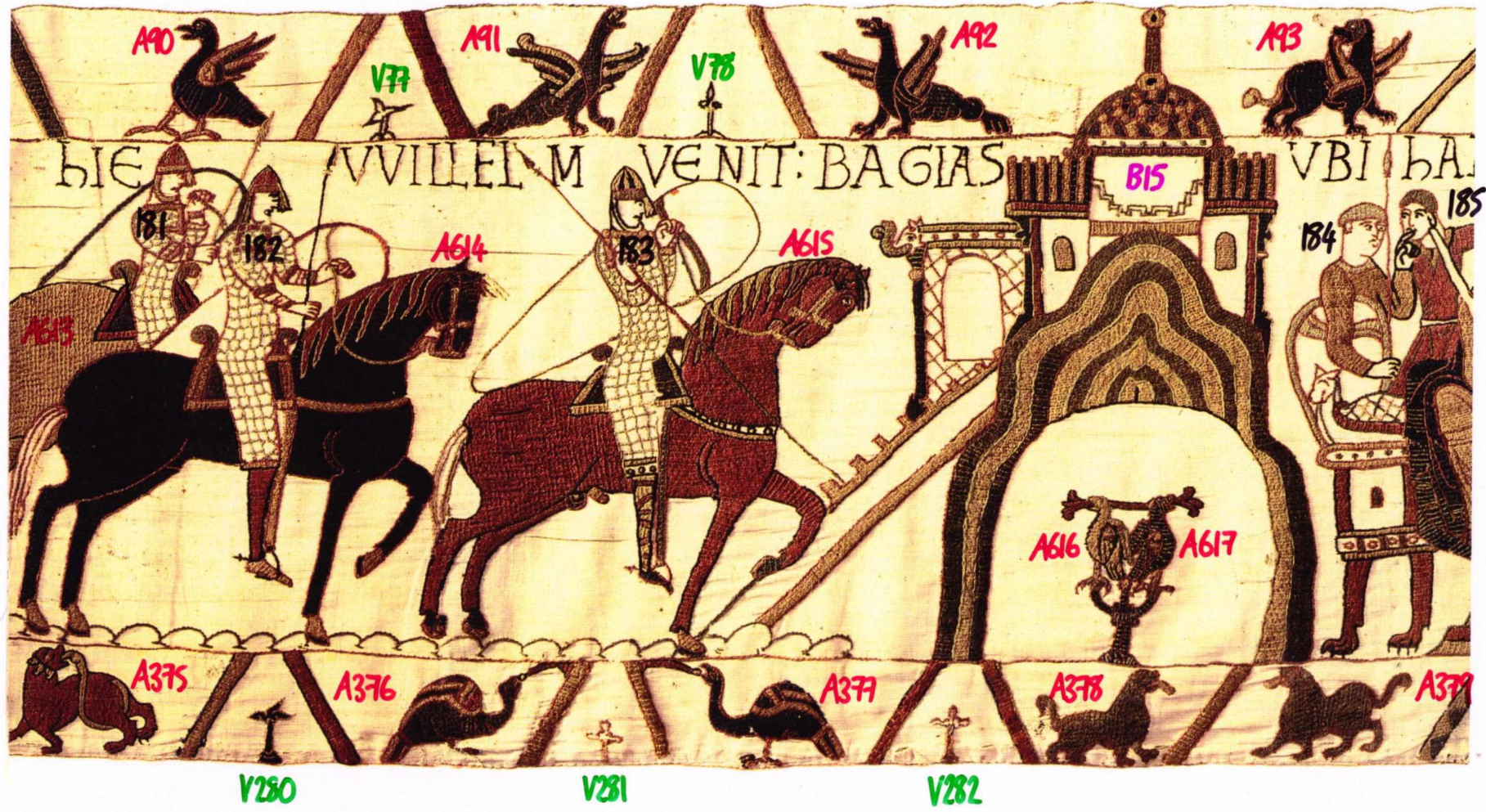

S.23



56

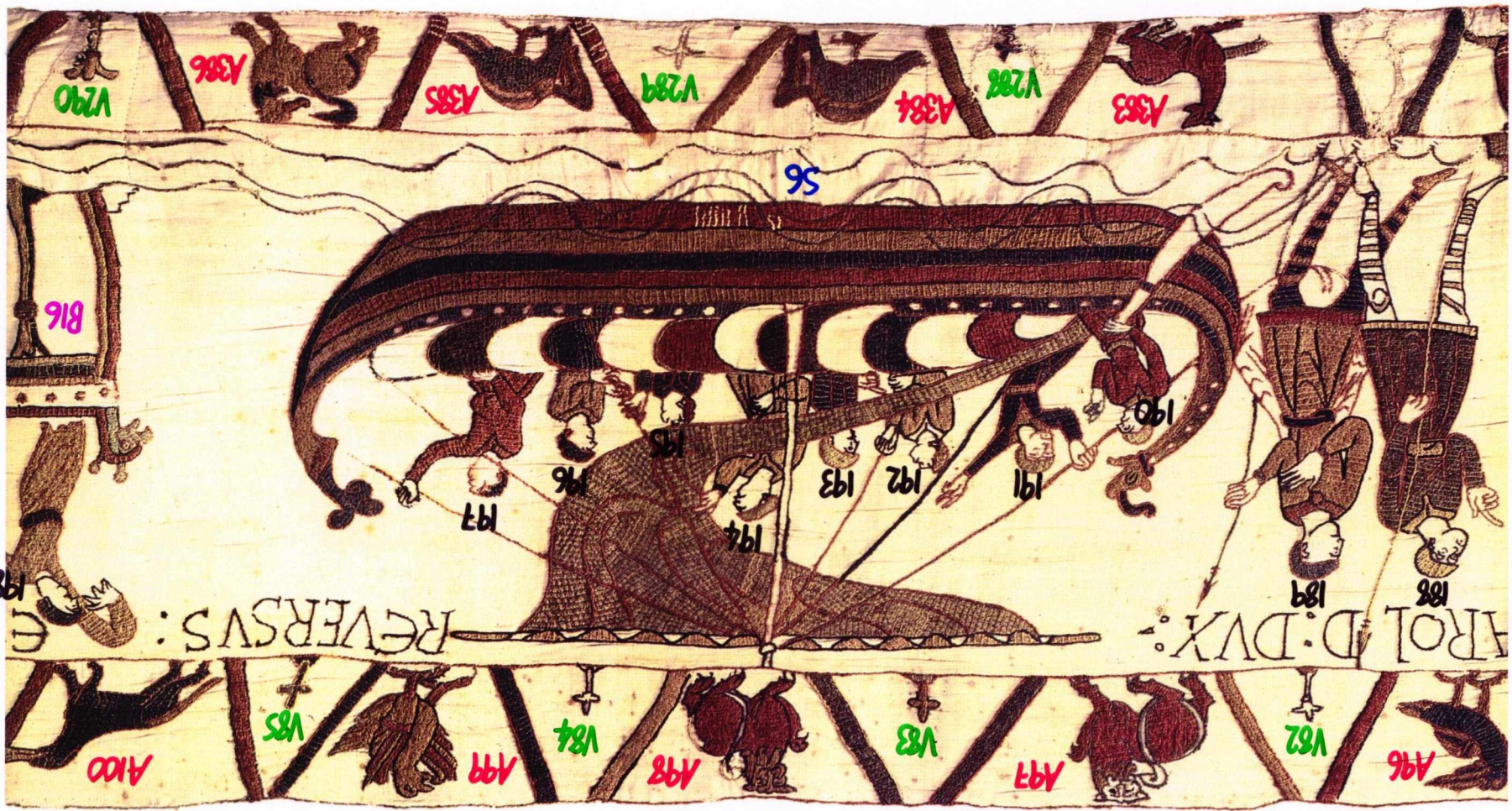

REVERSUS :

CAROL D. DVX :

V270

A386

A385

V284

A384

V282

A383

56

B16

197

196

194

193

192

191

190

189

188

198

A100

V85

A99

V84

A98

V83

A97

V82

A96

S.24

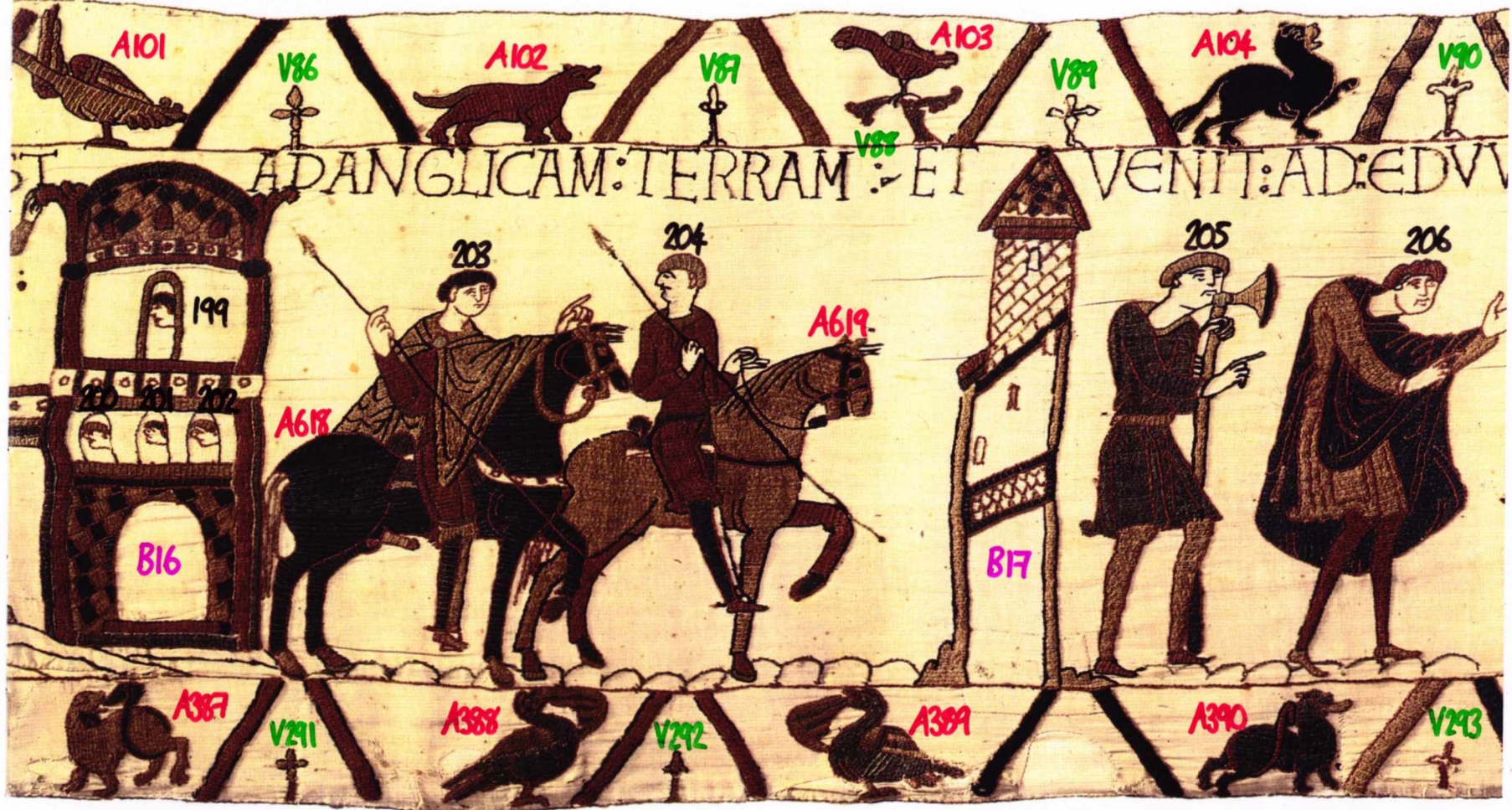

S.25



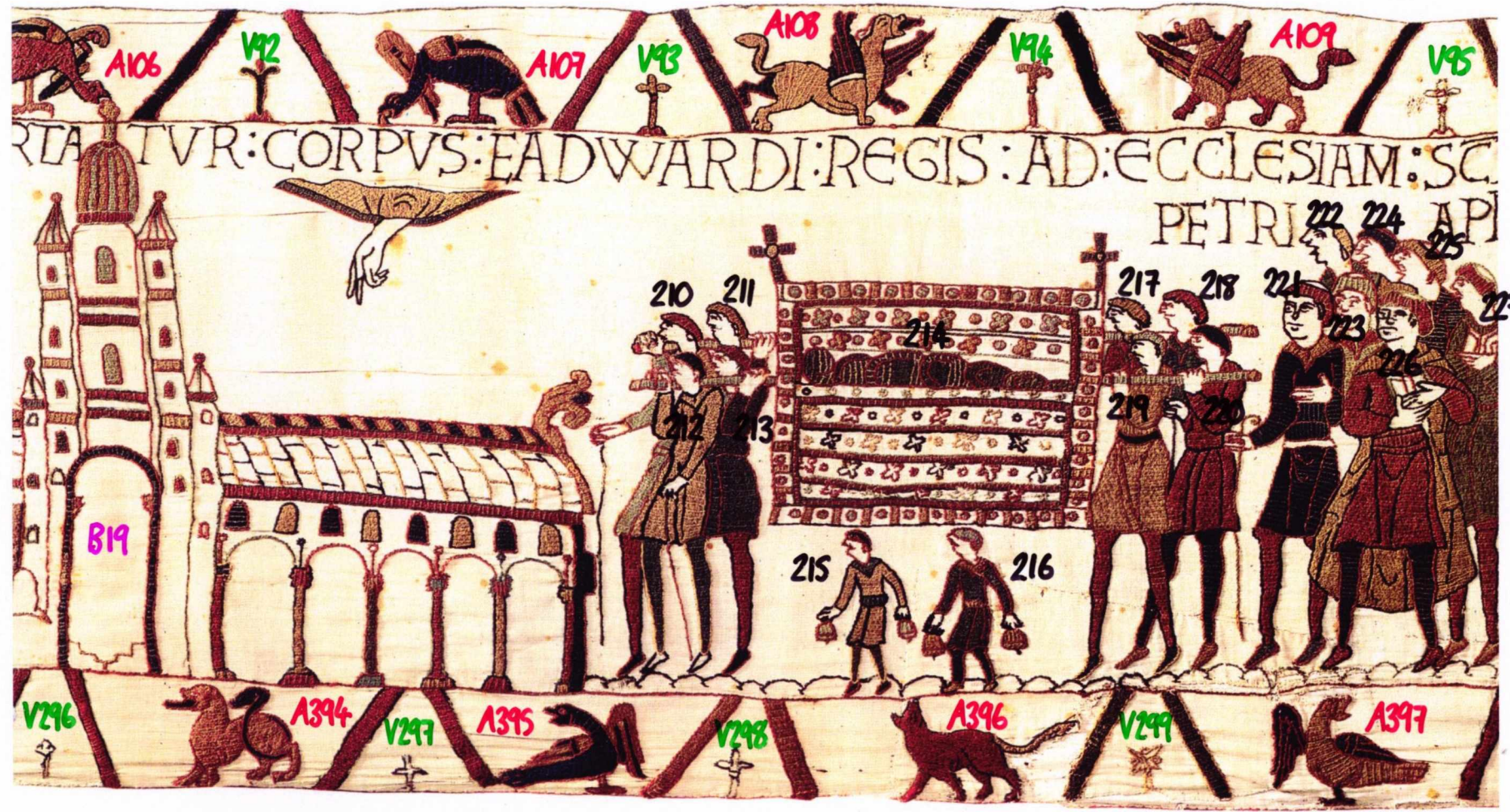

2 | 3

S.27-8

S.29

A110

HIC EADWARDVS: REX
INLECTO: ALLOQVIT: EIDE LES:

V96

A111

V97

B20

228

230

231

232

HIC DEDERVNT: HAROLD
CORO 237 NA: RE

229

238

239

ET HIC: 234 O DEFUNCTVS

233

EST

235

236

V301

A399

A400

V304

V305

V300

A398

V302

V303

A401

2 | 3



S.30

S.31

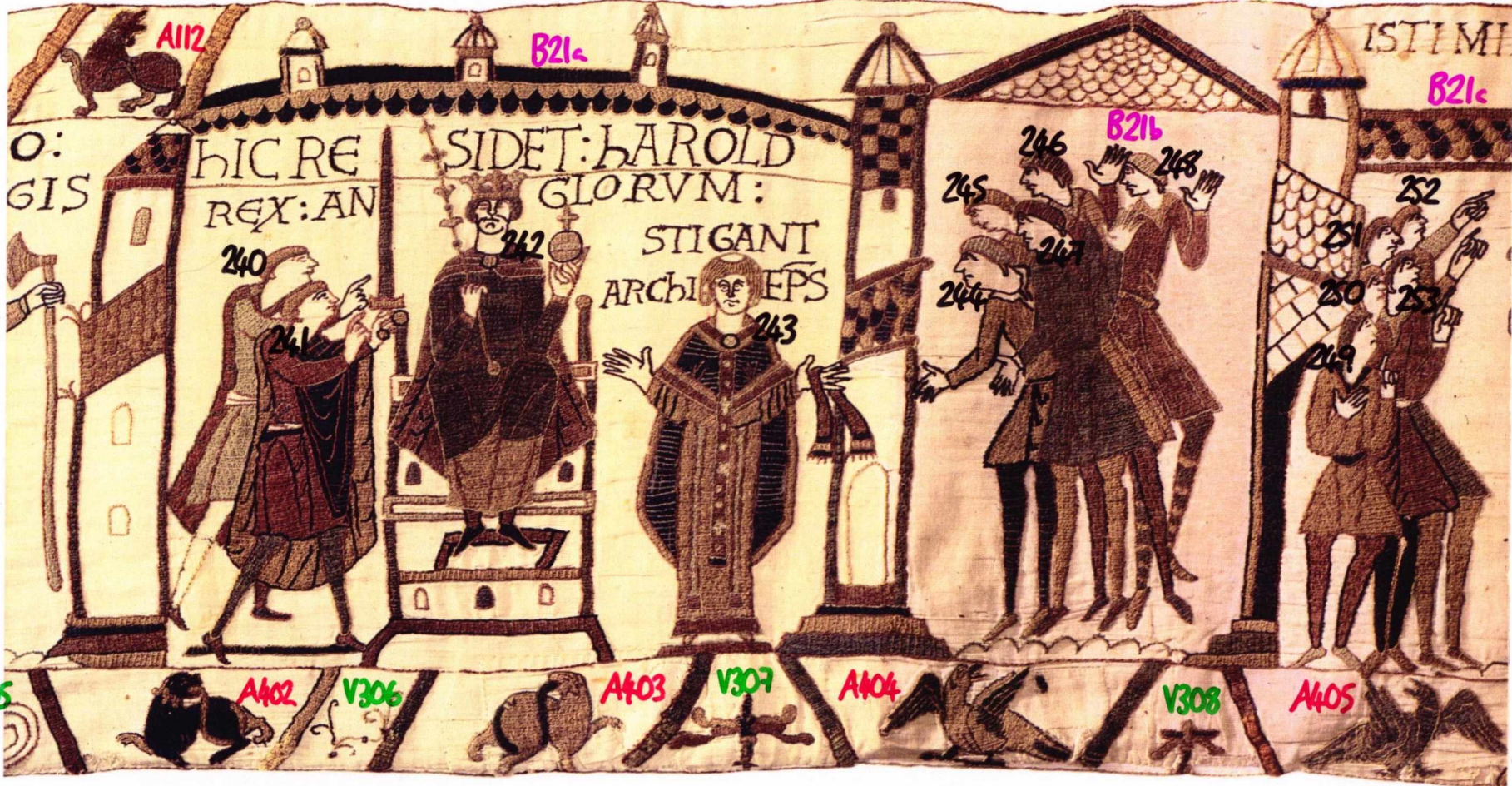

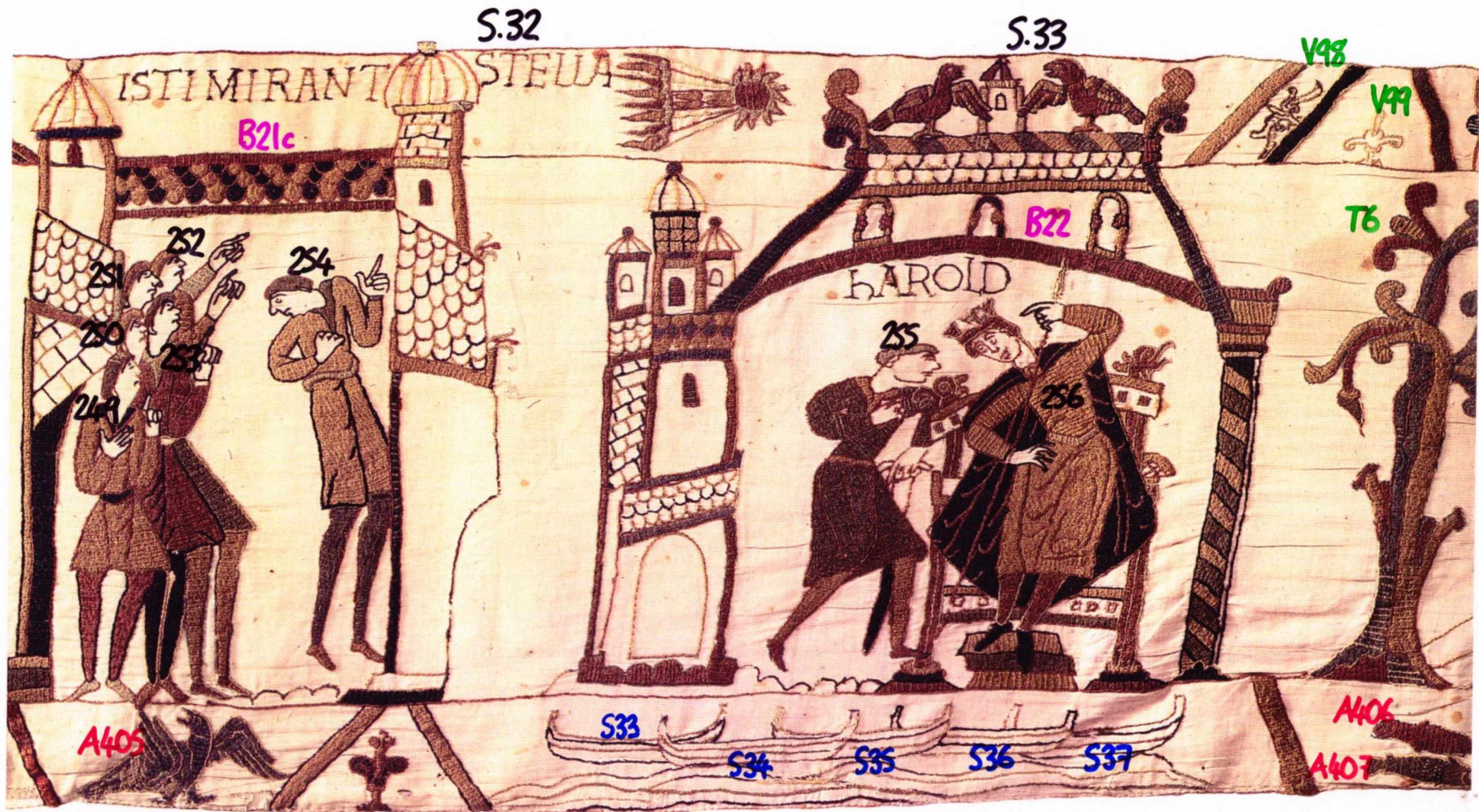

S.32

S.33

V98

V99

ISTI MIRANT STELLA

B21c

B22

T6

HAROLD

251

252

254

250

253

254

255

256

A405

S33

S34

S35

S36

S37

A406

A407

V309

S.34

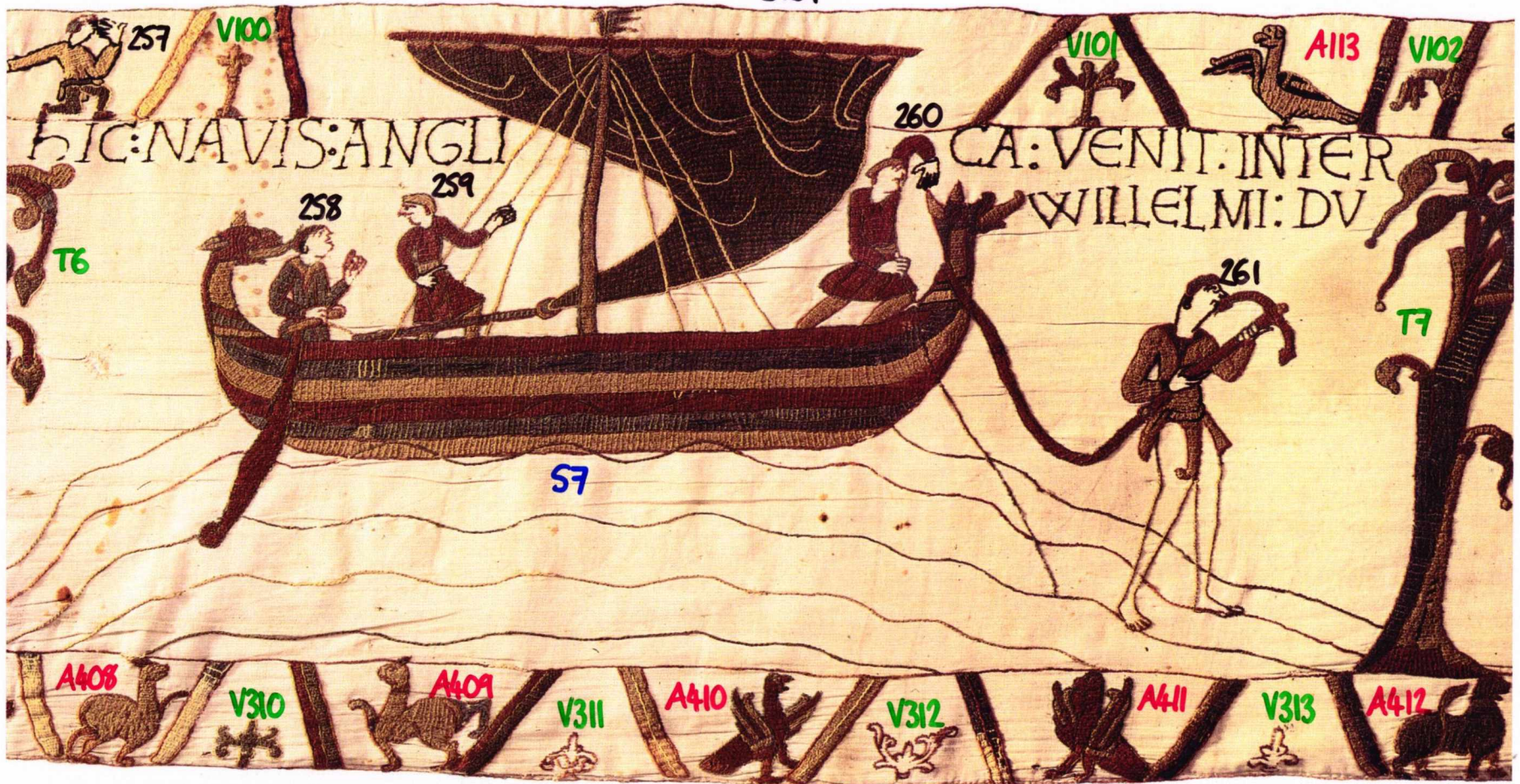

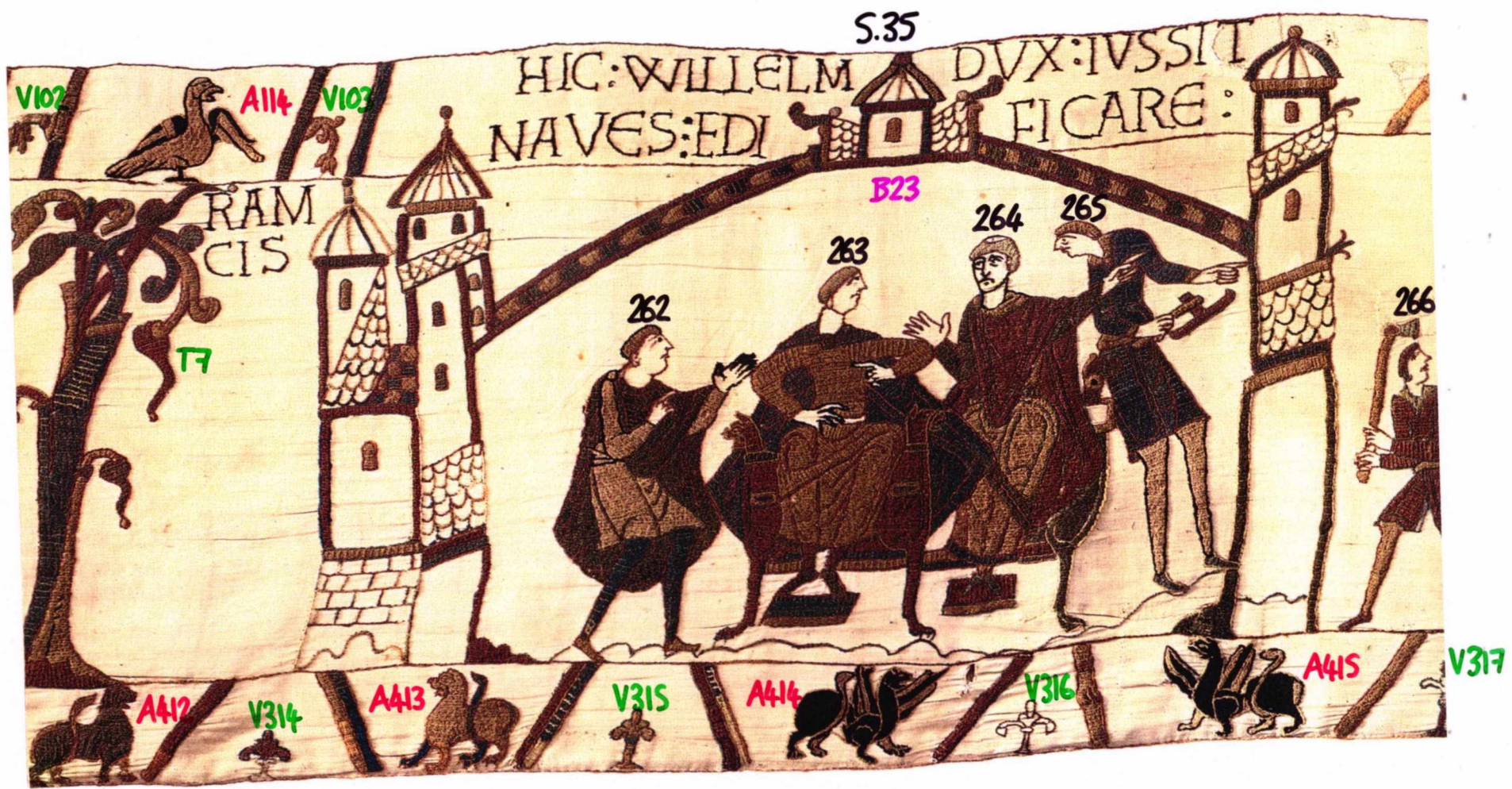

HIC: WILLELM NAVES: EDI DVX: IVSSIT FICARE:

RAM CIS

V102

A114

V103

S.35

T7

B23

262

263

264

265

266

A412

V314

A413

V315

A414

V316

A415

V317

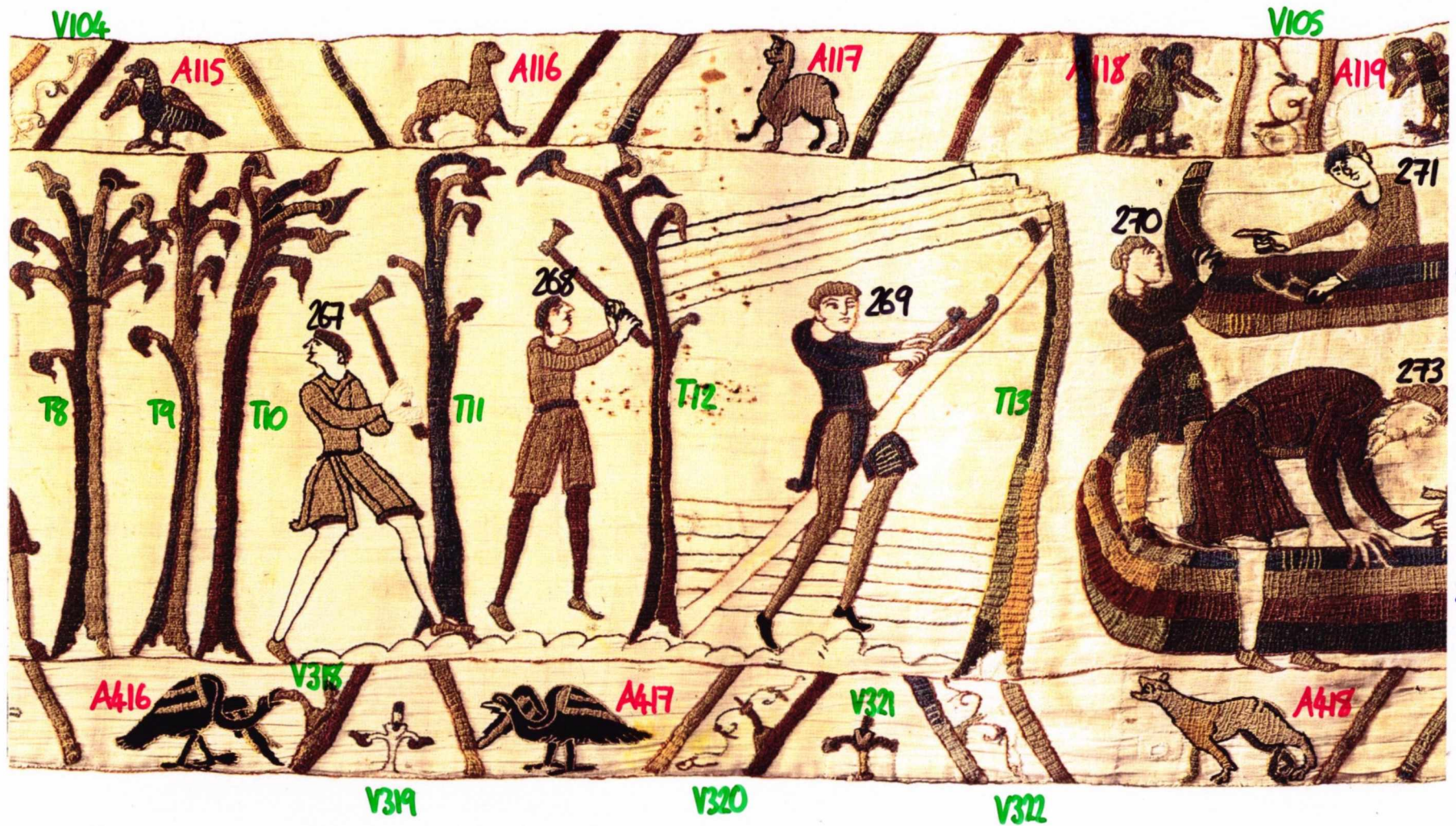

V106



V105

V32R

V32L

VICIRAI

A118

A119

A120

A121

A418

A419

A421

270

271

272

273

274

S8

S9

S10

S11

S12

S13

S14

T13

T14

V107 S:36

EDIN

V108

V109



A123

A124

A125

VNT: NAVES: ADMA RE:-

276

278

279

277

275

824

280

281

285

284

A410

A423

A424

A425

V324

V325

V326

V327

S.37

VIII



A128

A127

A126

A125

VIC9

A124

PORTIANI: ARMAS: ADI TRI CVM

287

284

281

280

288

285

283

282

A128

A127

A126

A125

A124

V32A

V32B

V32A

3 | 4



A128

A129

V112

A130

V113

A131

V114

AVES: ET HIC SVNT: CARRVM VINO: ET ARM IS + HIC: WVILL ELM: DVX INMAGN O:

289

290

291

292

A620

293

A621

294

A622

295

296

A623

A429

V330

A430

V331

A431

V332

A432

V333

3 | 4

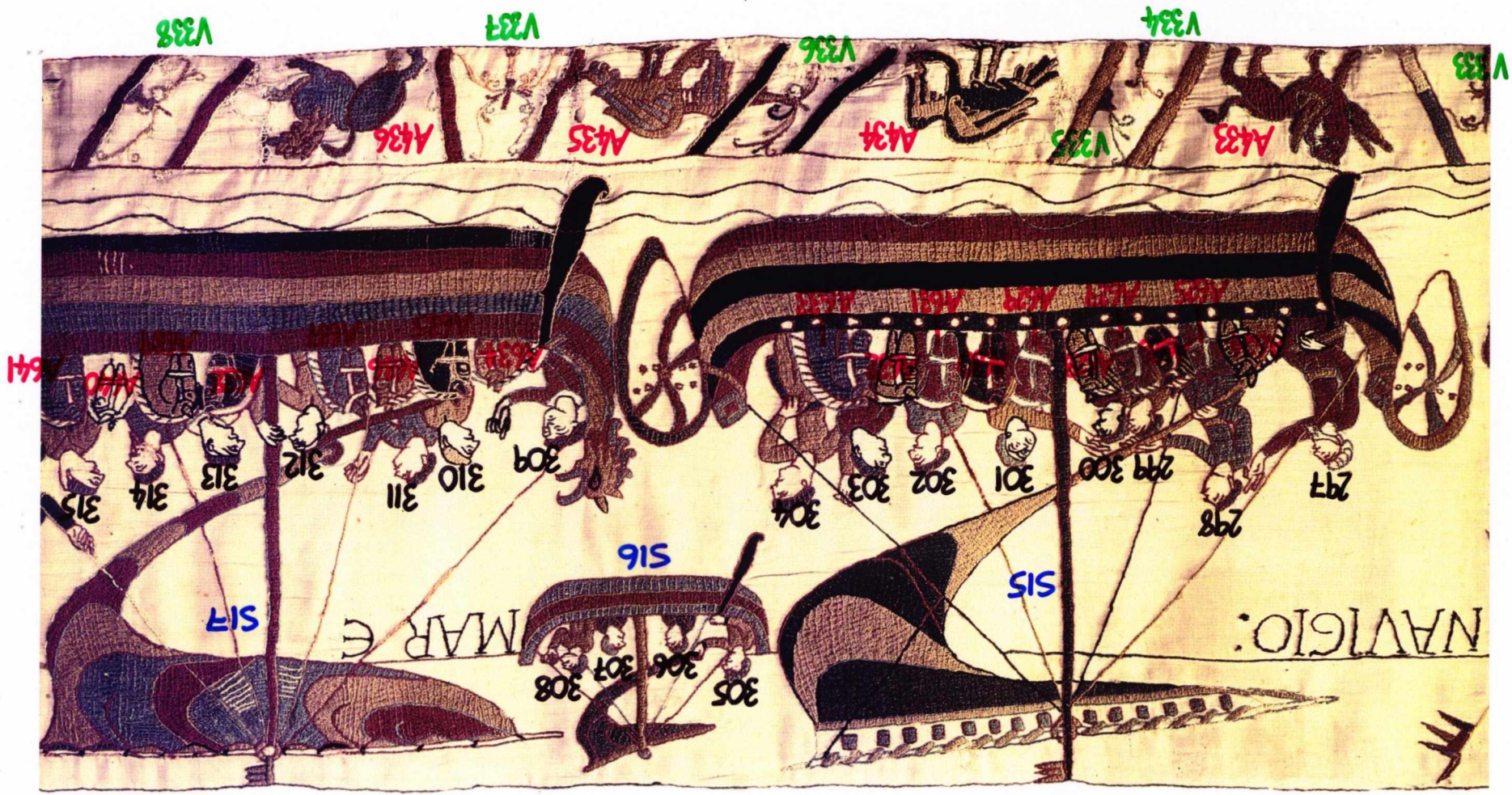

S.38

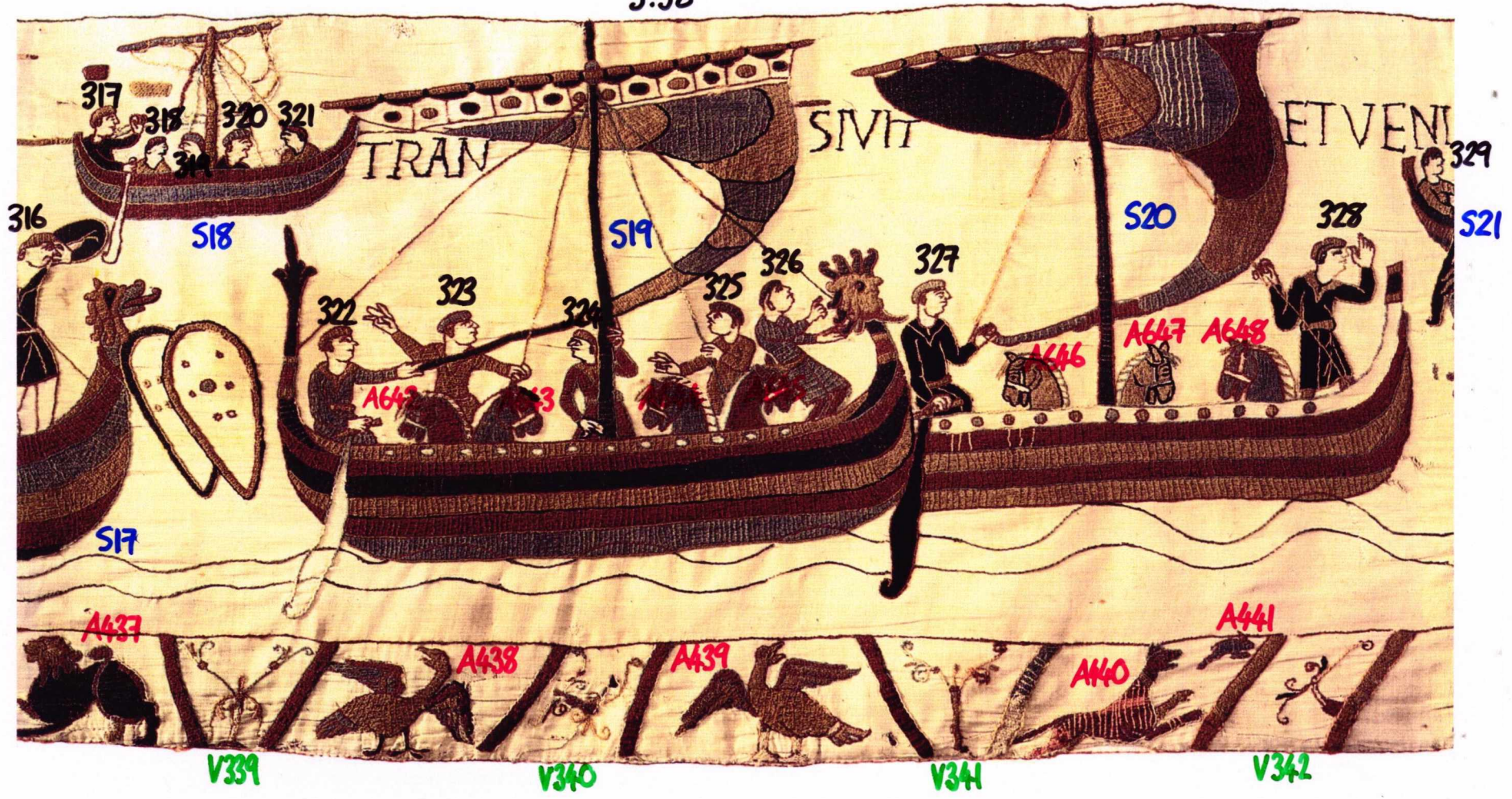

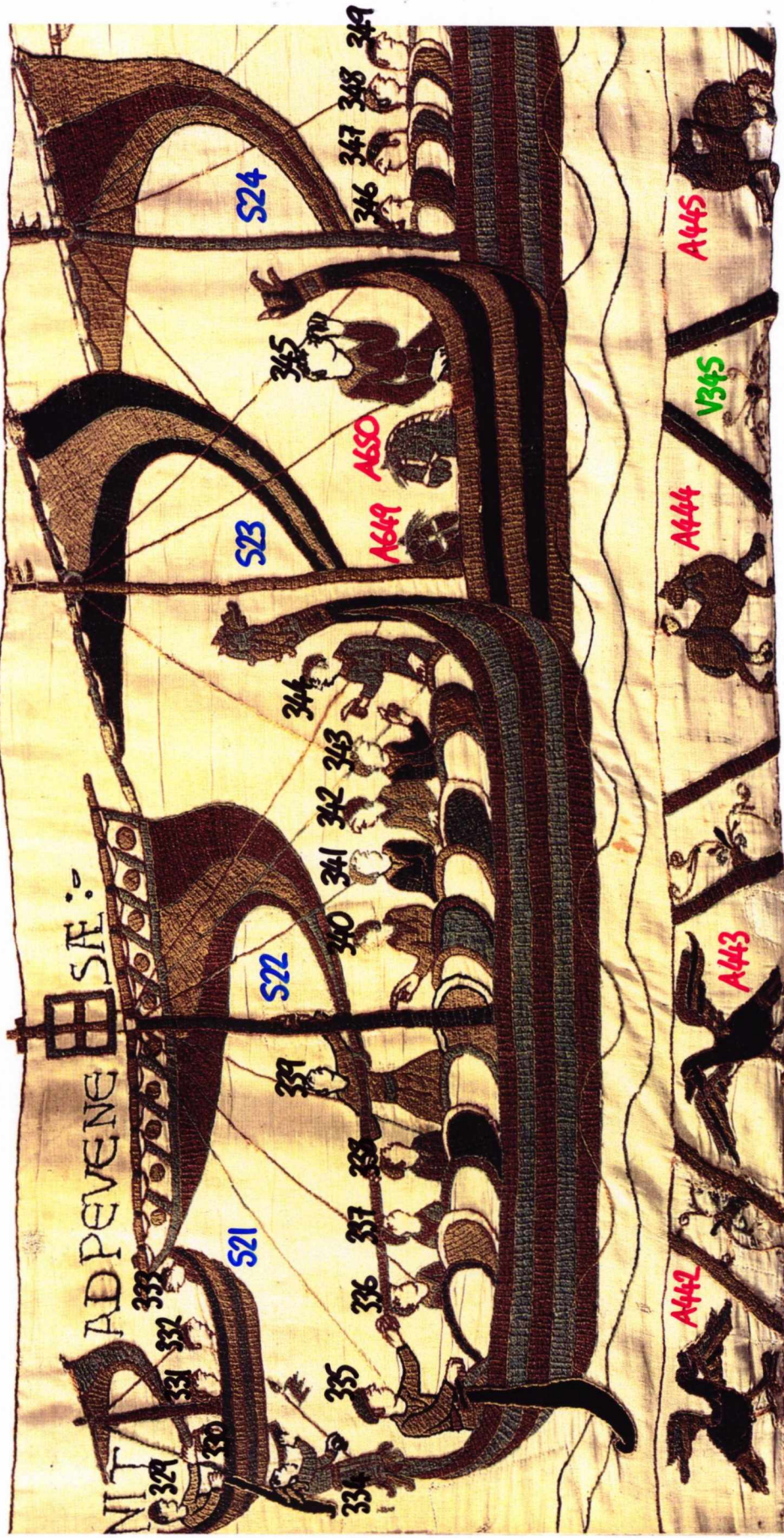

NIT ADPEVING SÆ :-

329

330

331

332

333

334

335

336

337

338

339

340

341

342

343

344

345

346

347

348

349

S21

S22

S23

S24

A649

A650

A442

A443

A444

A445

V343

V344

V345

S.39

VIS



S24

350

351

S25

353

354

355

356

DENAVIBVS: -

S27

S28

357

V34A

V35A

V34B

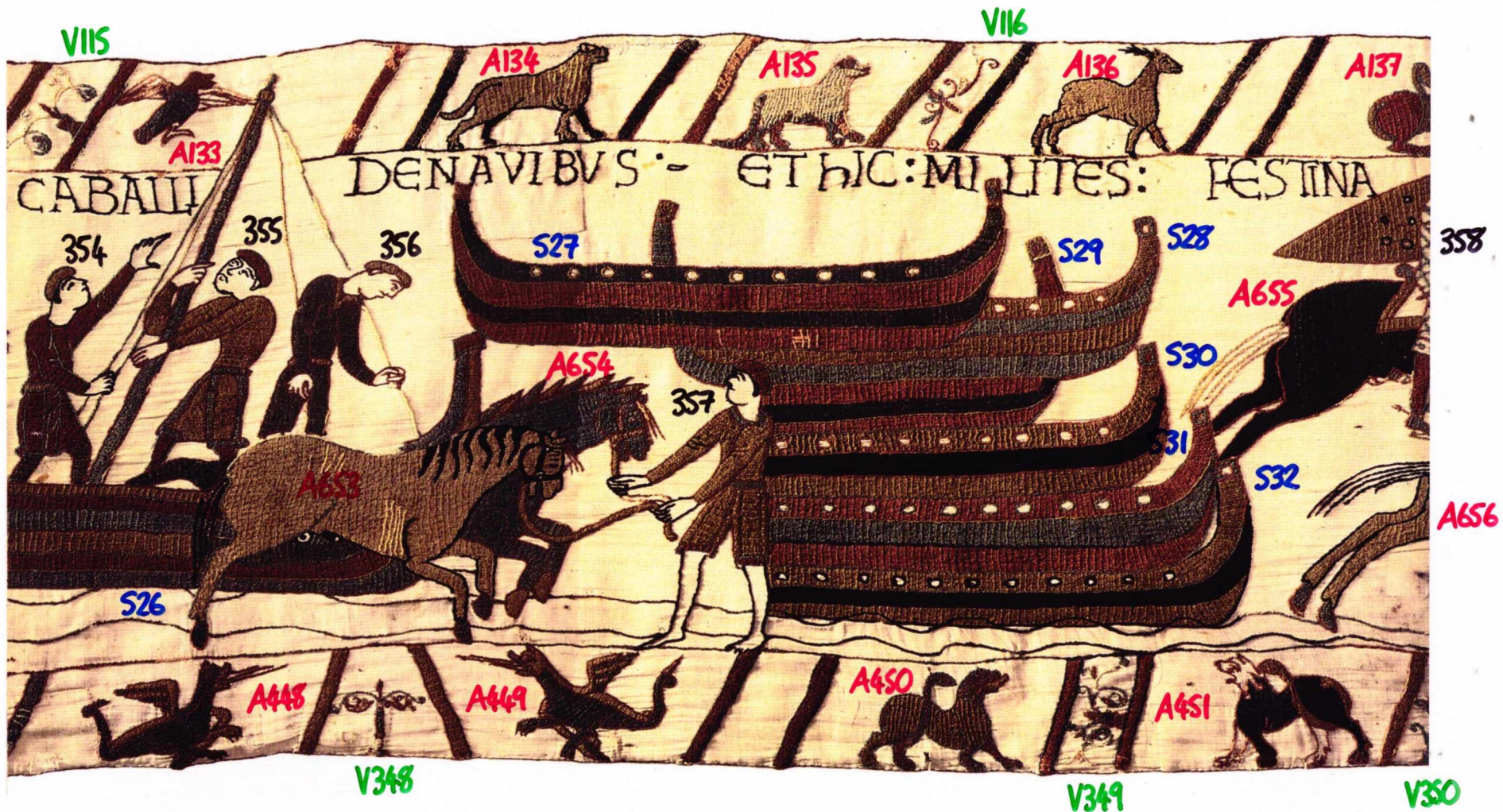

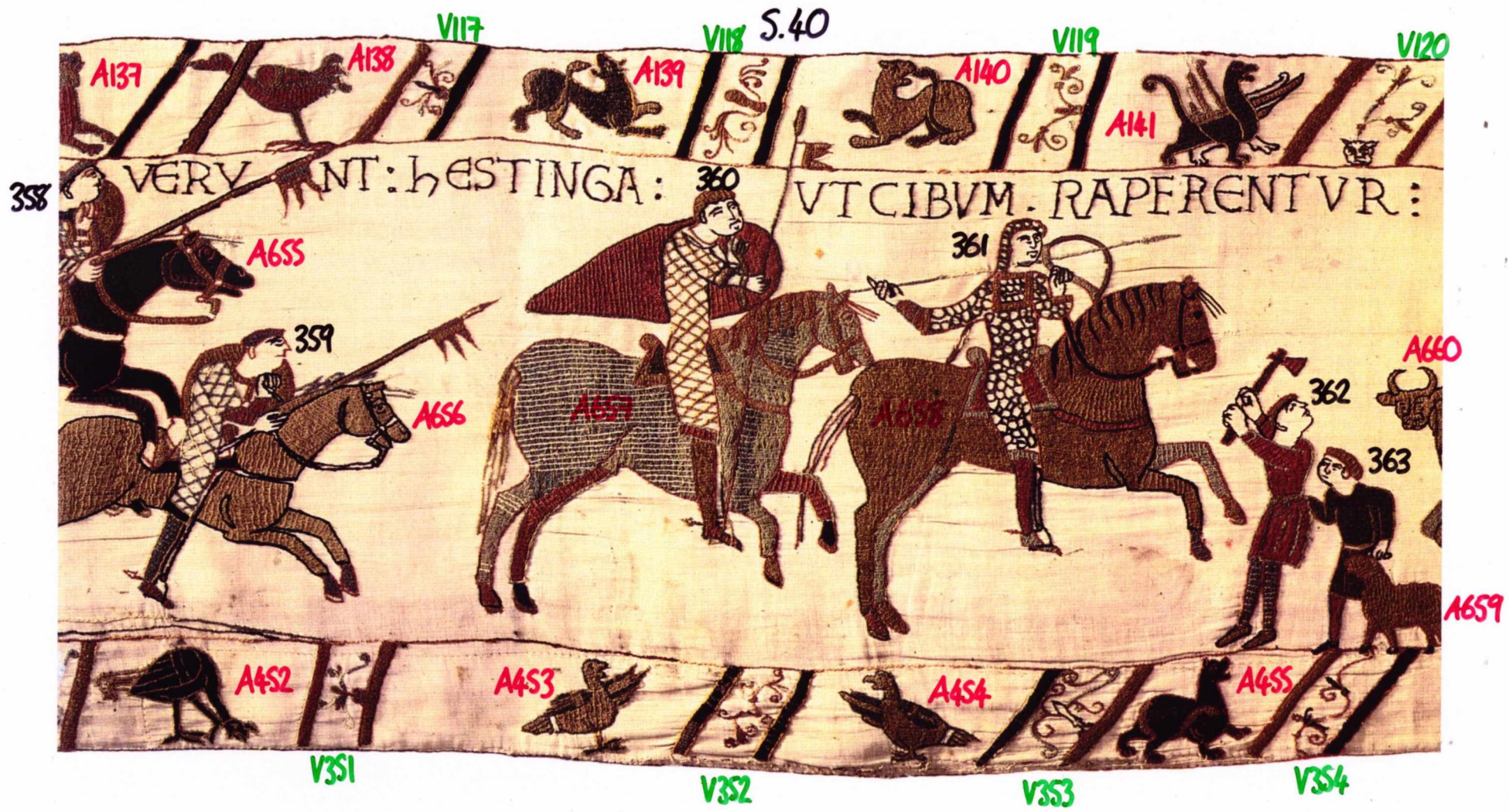

A137

A138

V117

A139

V118 S.40

A140

V119

A141

V120

358

VERY ANT: hESTINGA:

360

UTCIBVM. RAPERENT VR:

A655

359

A656

A657

361

A658

A660

362

363

A659

A452

V351

A453

V352

A454

V353

A455

V354



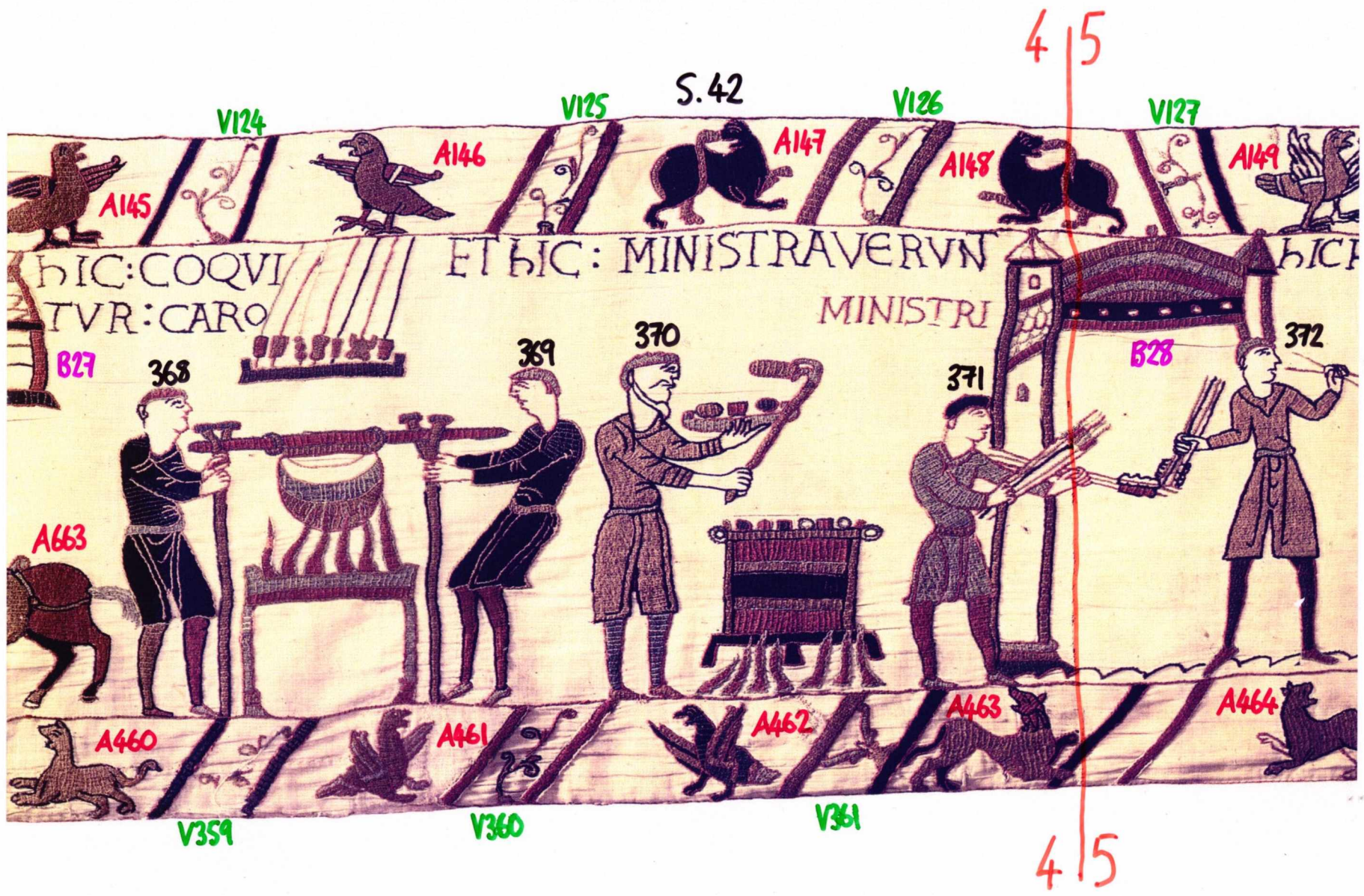

HIC: COQVI
TVR: CARO

ET HIC: MINISTRAVERVN
MINISTRI

HIC

B27

368

369

370

371

372

A663

B28

A460

A461

A462

A463

A464

V359

V360

V361

4 | 5

4 | 5

V124

V125

S.42

V126

V127

A145

A146

A147

A148

A149

4 | 5

V127

V128

V129 S.43

V130



A148

A149

A150

A151

A152

RVN
STRI

HIC FECERVN: PRANDIVM:

ET HIC EPISCOVS: CIB
POTV NE DIC

371

B28

372

373

374

375

376

377

378

379

380

381

383

A463

A464

A465

A466

A467

V362

V363

V364

4 | 5

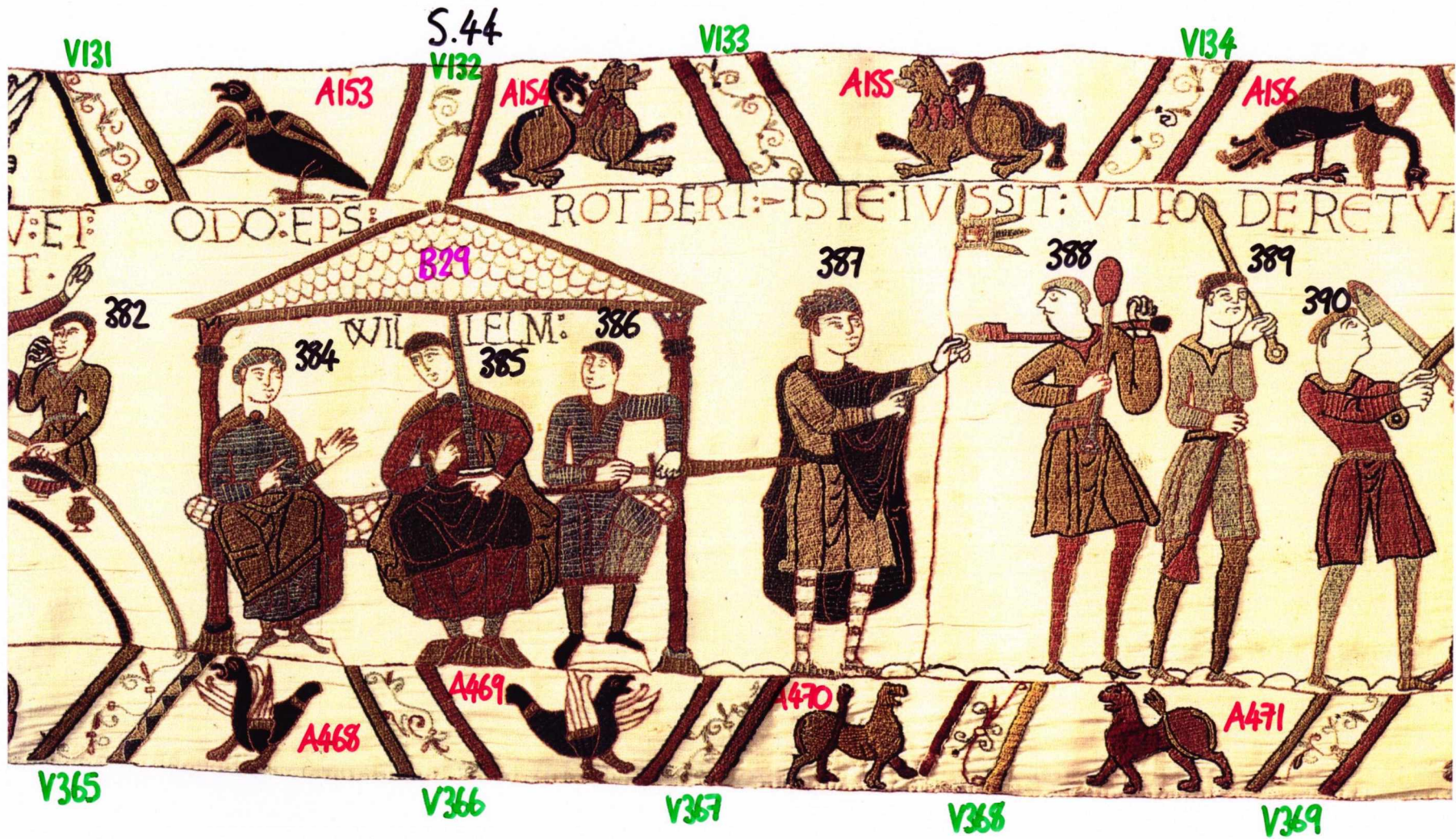

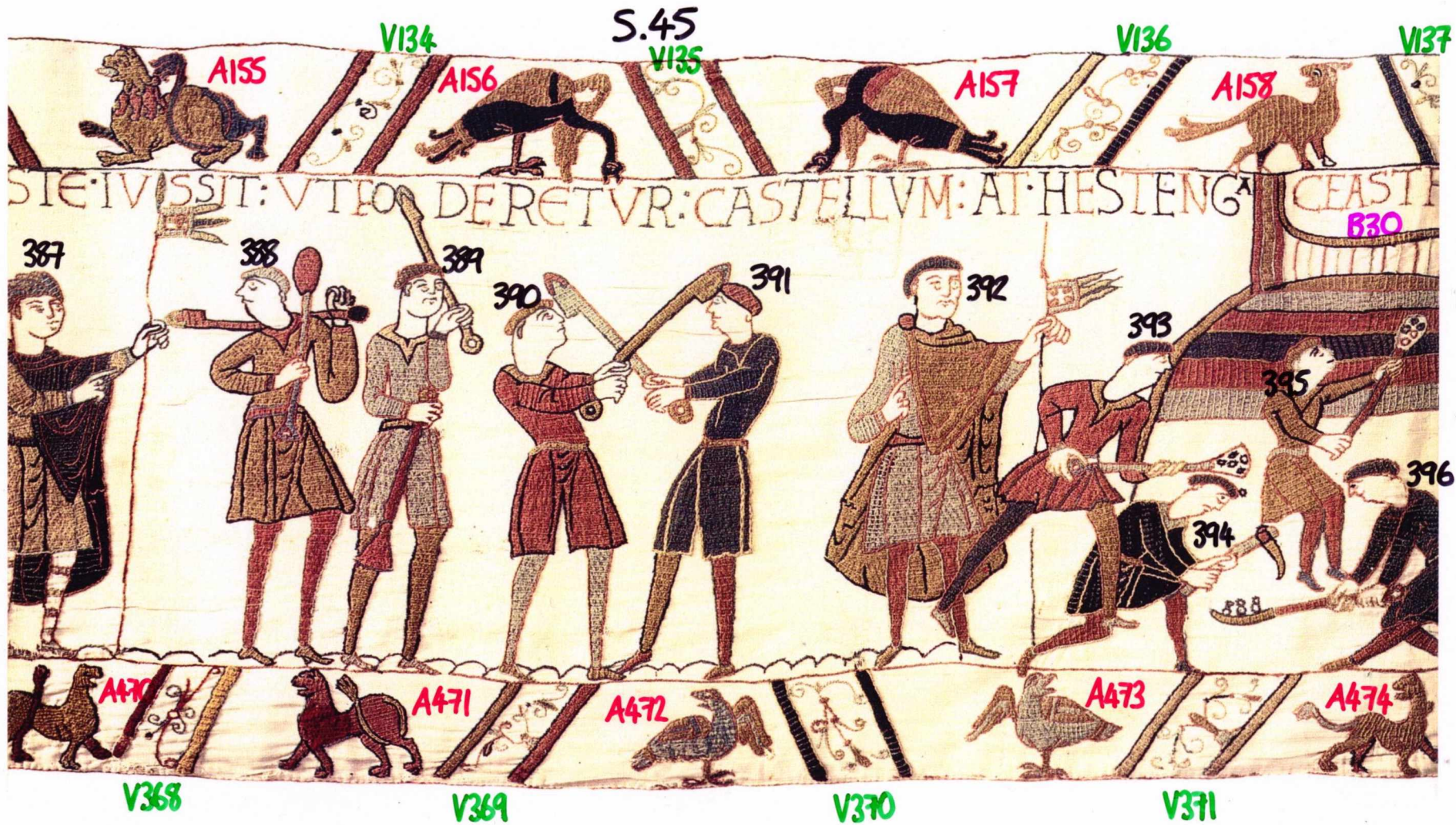

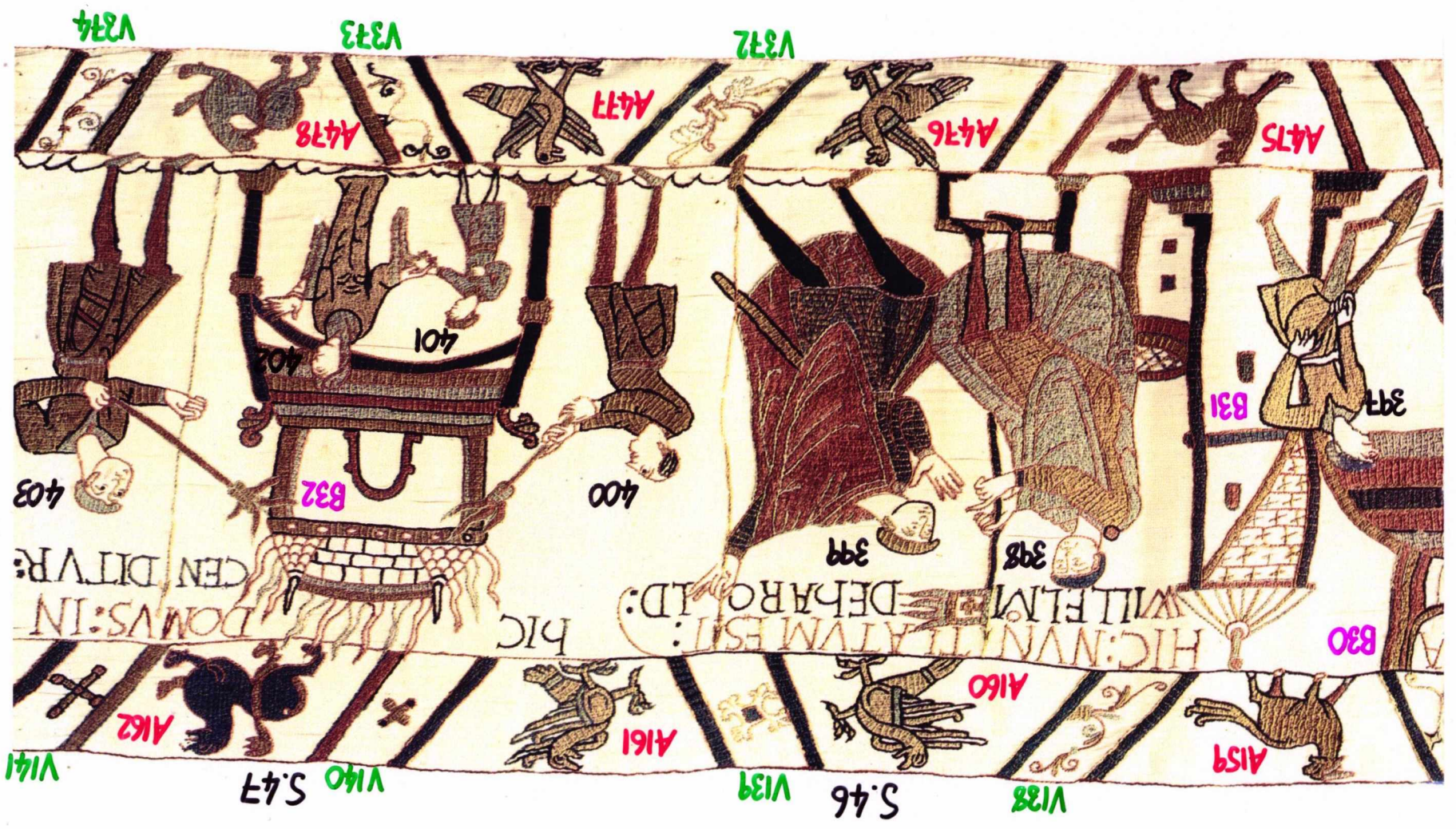

V374

V373

V372

A478

A477

A476

A475

401

402

400

403

B32

399

398

B31

397

DONVS:IN:
CEN DITVR:

HIC:NVN:ITAVM:EST:
DEHAROLD:ID:
WILHELM:

B30

A162

A161

A160

A159

V141

S.47
V140

V139

S.46

V138



V145

A167

T75

V144

A166

405

A664

A483

V143

A165

404

A482

V377

A164

A481

V376

V142

A163

B33

A480

V375

A477

A167

V146



406

407

A168

V147

S.48

V148

418

419

T15

E: VENERVNI

T17

T16

417

416



408

409

411

412

413

414

415

416

417

A663

A664

A665

A666

A667

A670

A671

A672

A673

A674

A675

A676

A677

A678

A679

A680

A681

A682

A683

A684

A685

A484

A485

A486

A487

A488

V378

V379

V380

5 / 6



5 / 6

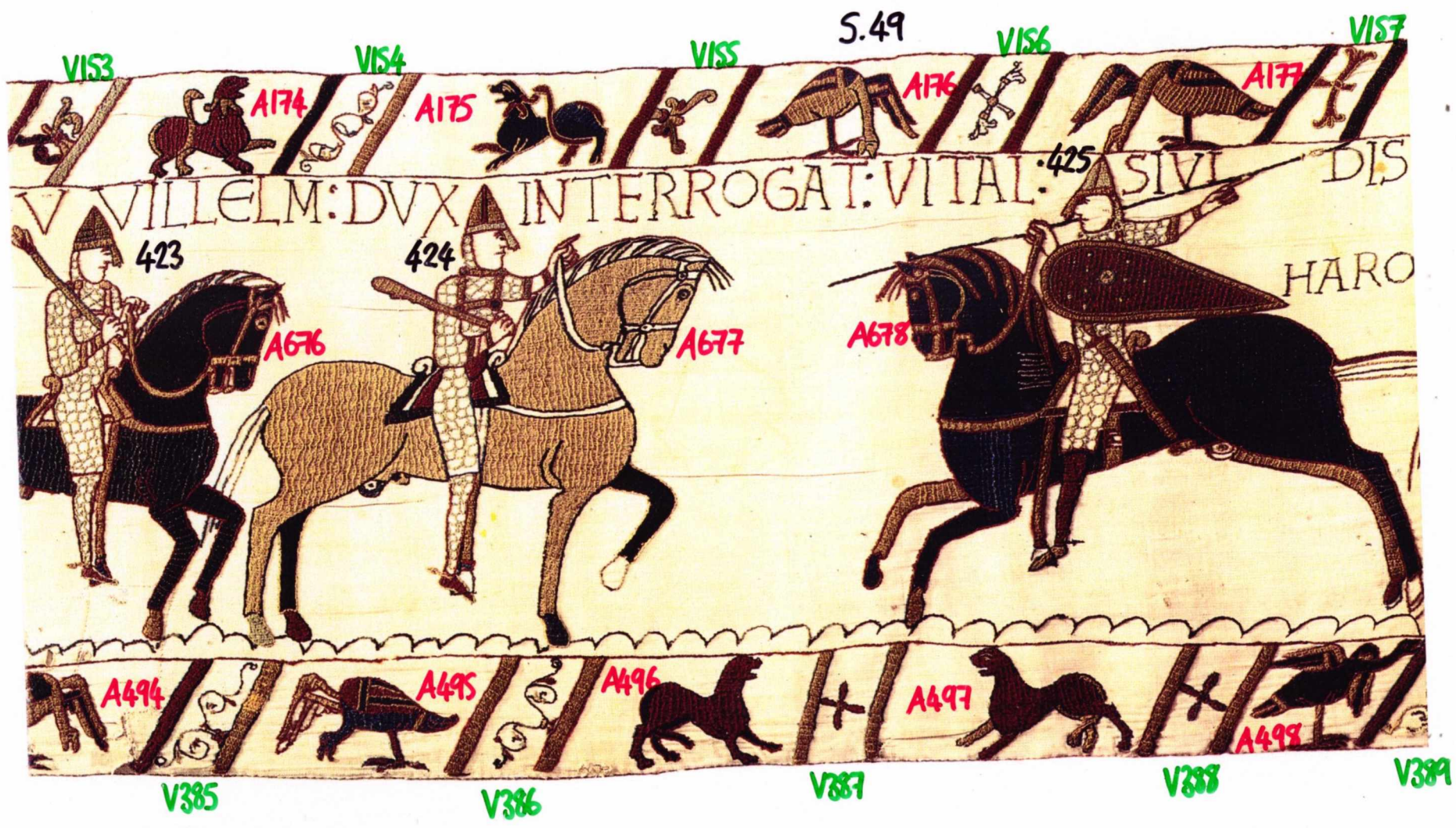

VIS3

VIS4

VIS5

S.49

VIS6

VIS7

A174

A175

A176

A177

423

424

425

A676

A677

A678

V WILLELM: DVX INTERROGAT: VITAL: SIVI DIS

HARO

A494

A495

A496

A497

A498

V385

V386

V387

V388

V389

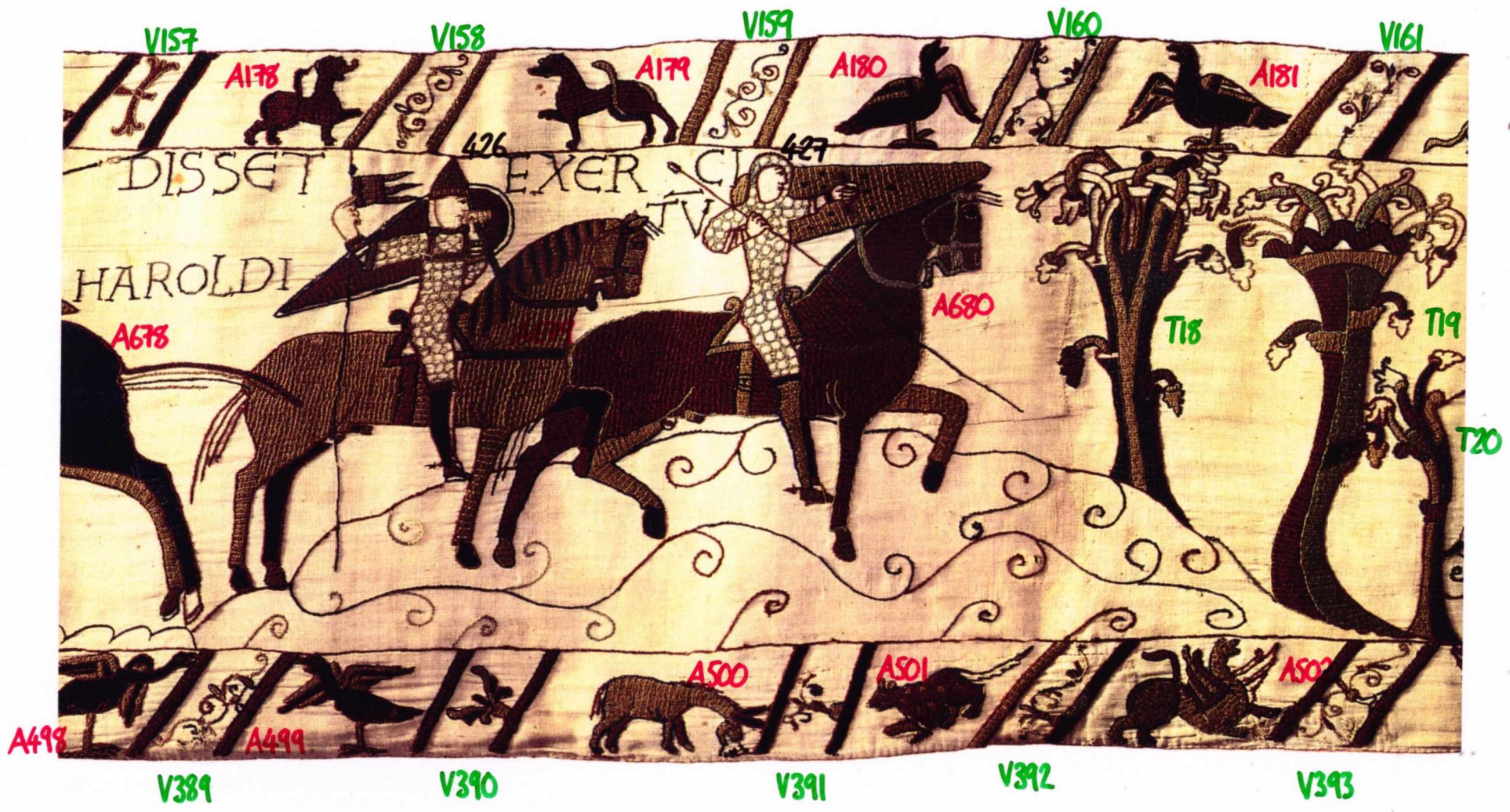

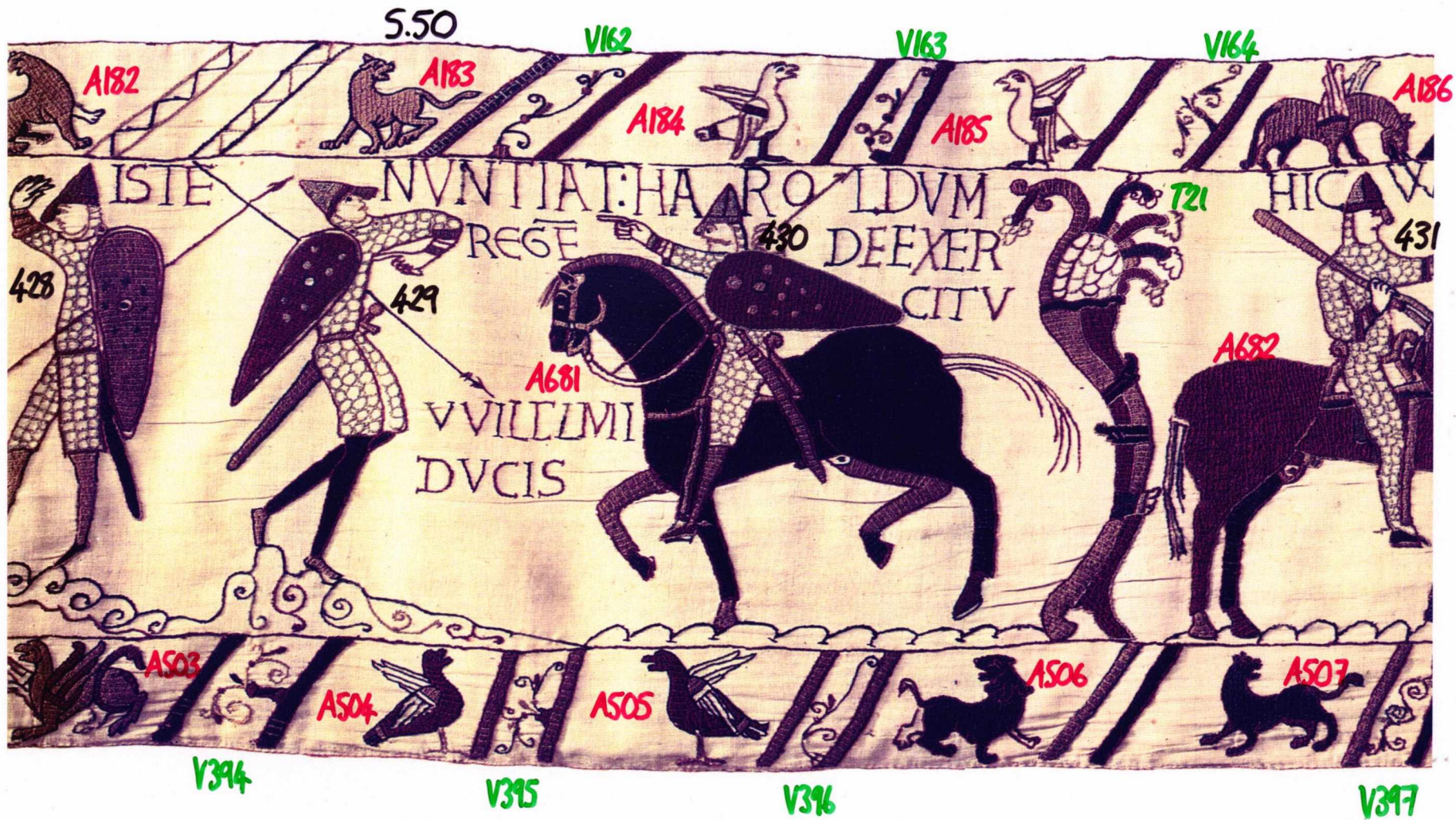

V164

A186

V165

A187

V166

A188

V167

A189

V168

A190

T21



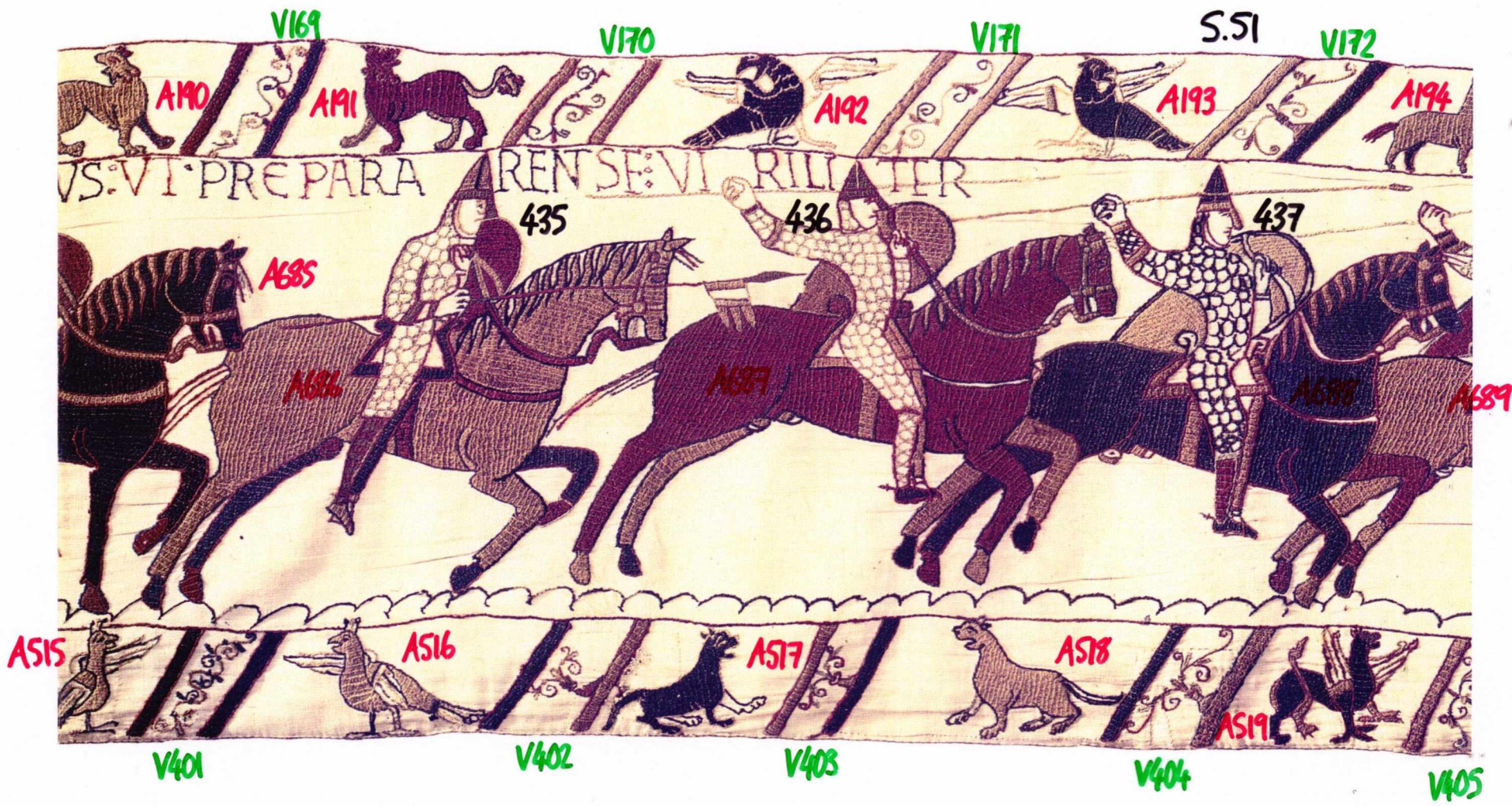

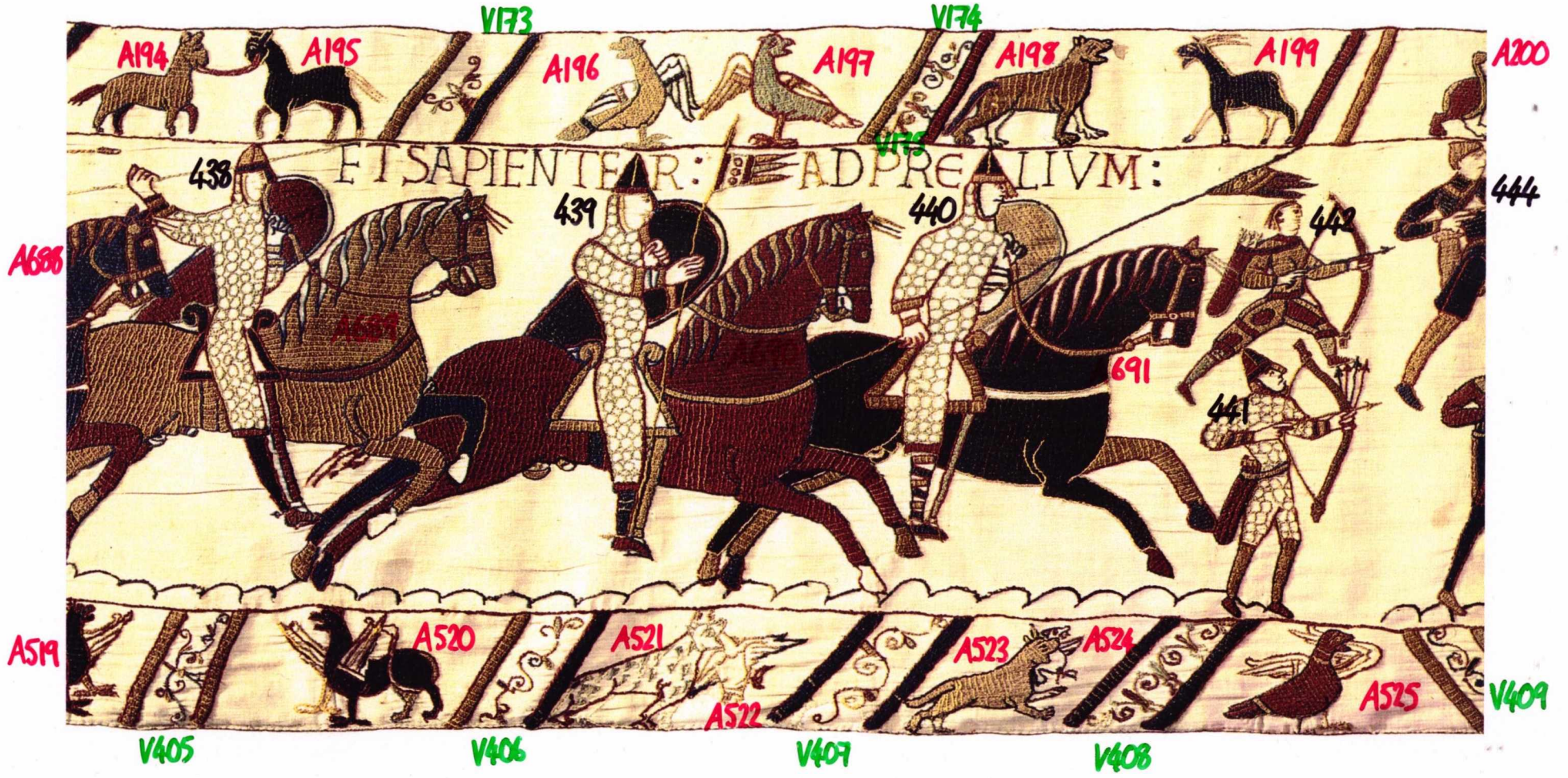

67

V176

V177

V178

V180

V181

A200

A201

A202

A203

A204

A205

CONRAN

GLOMEXER

450

444

445

446

447

448

449

A697



V409

A526

A527

A528

A529

A530

V410

V411

V412

V413

67

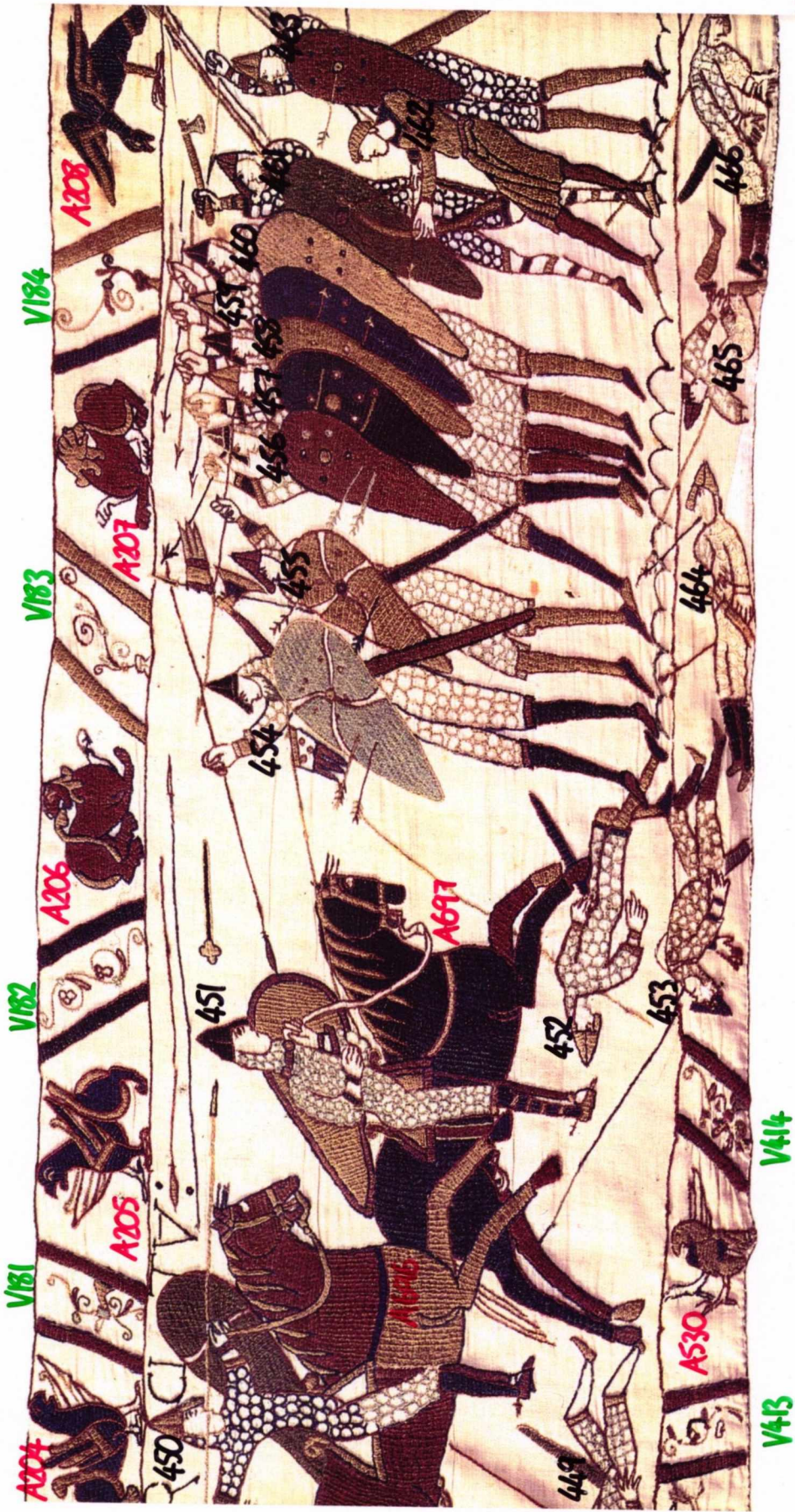

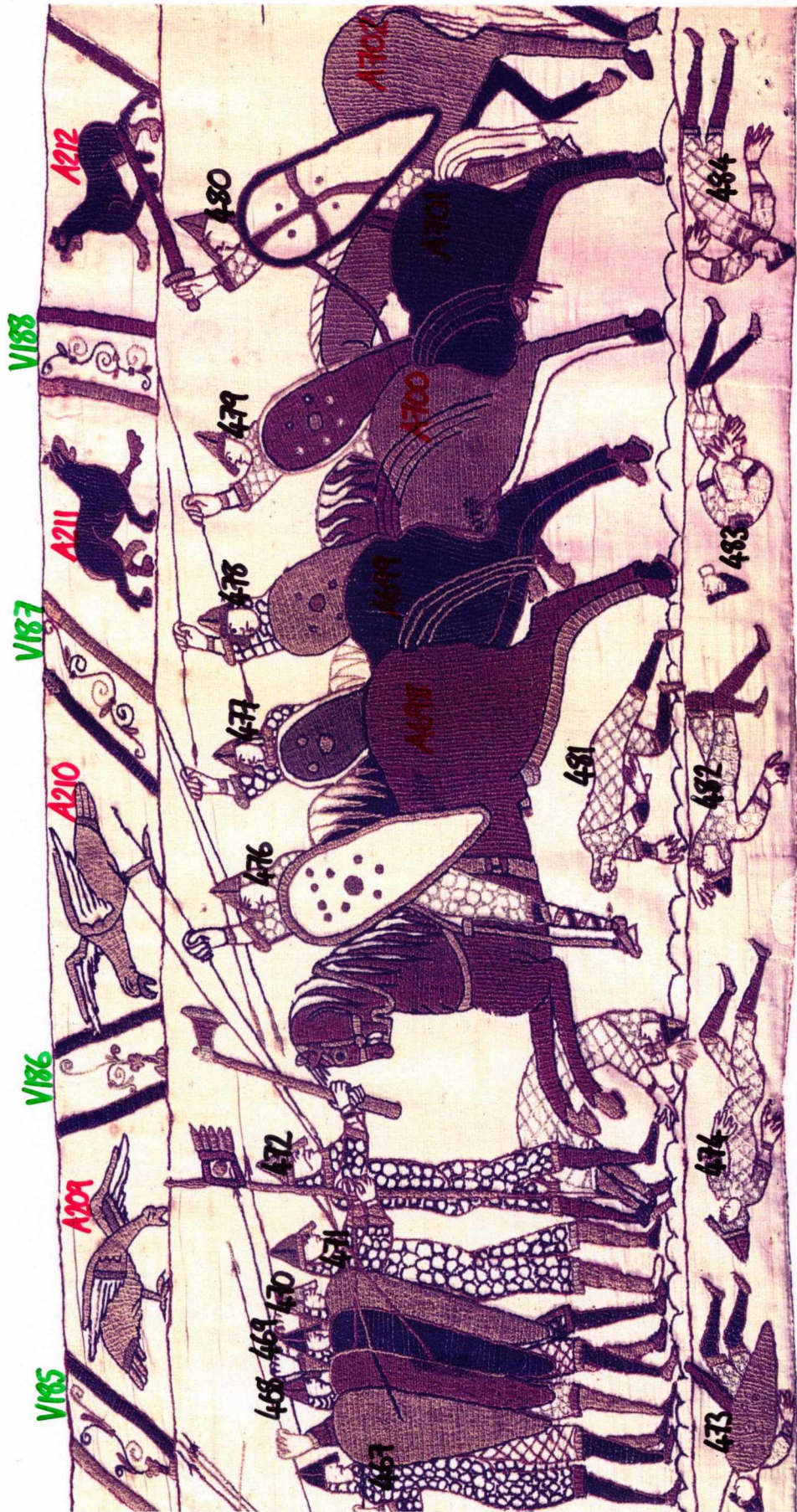

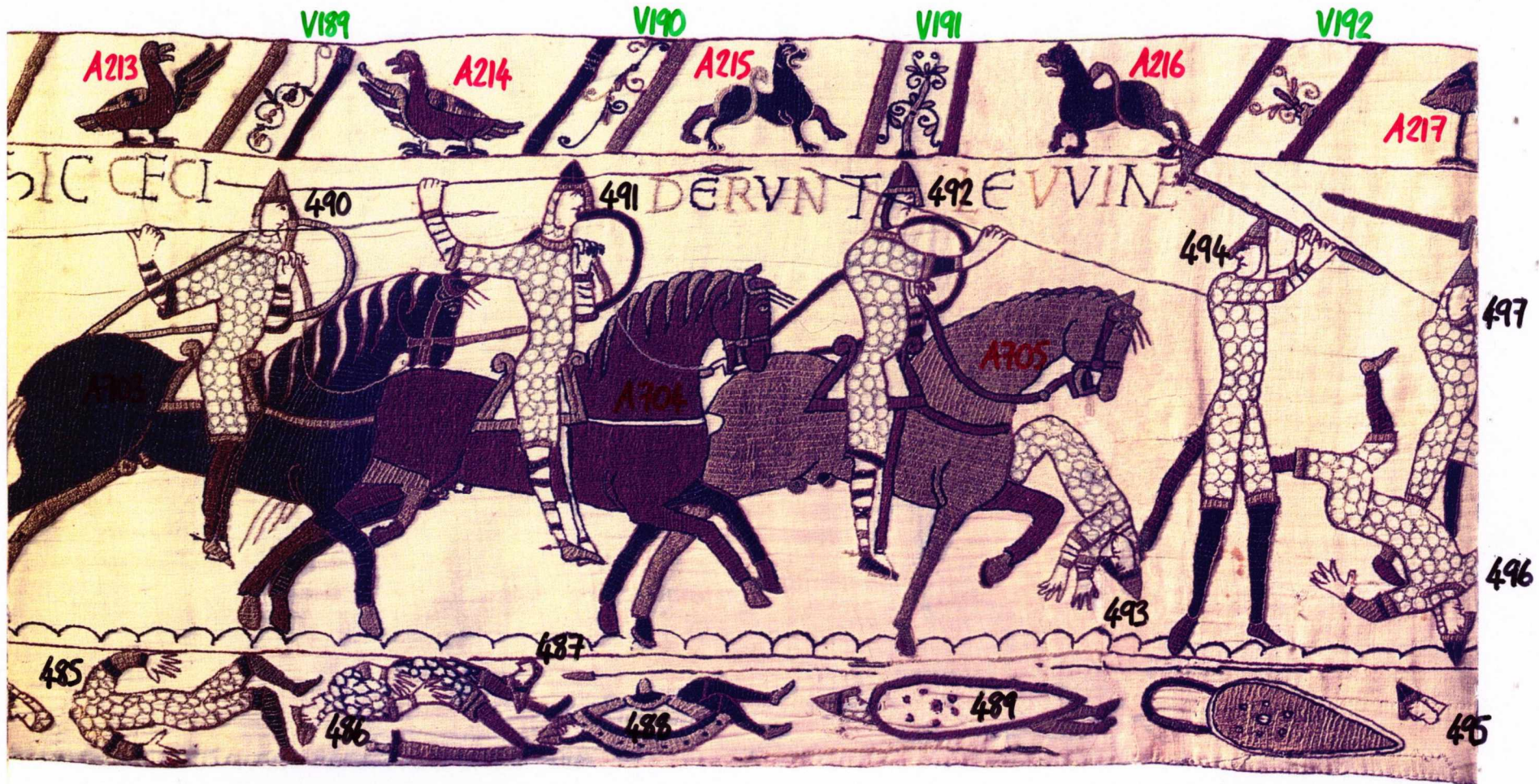

V193

S.52

V194

V195

V196

V197

V198

V199

V200

V201

V202

V203

V204

V205

V206

V207

V208

V209

V210

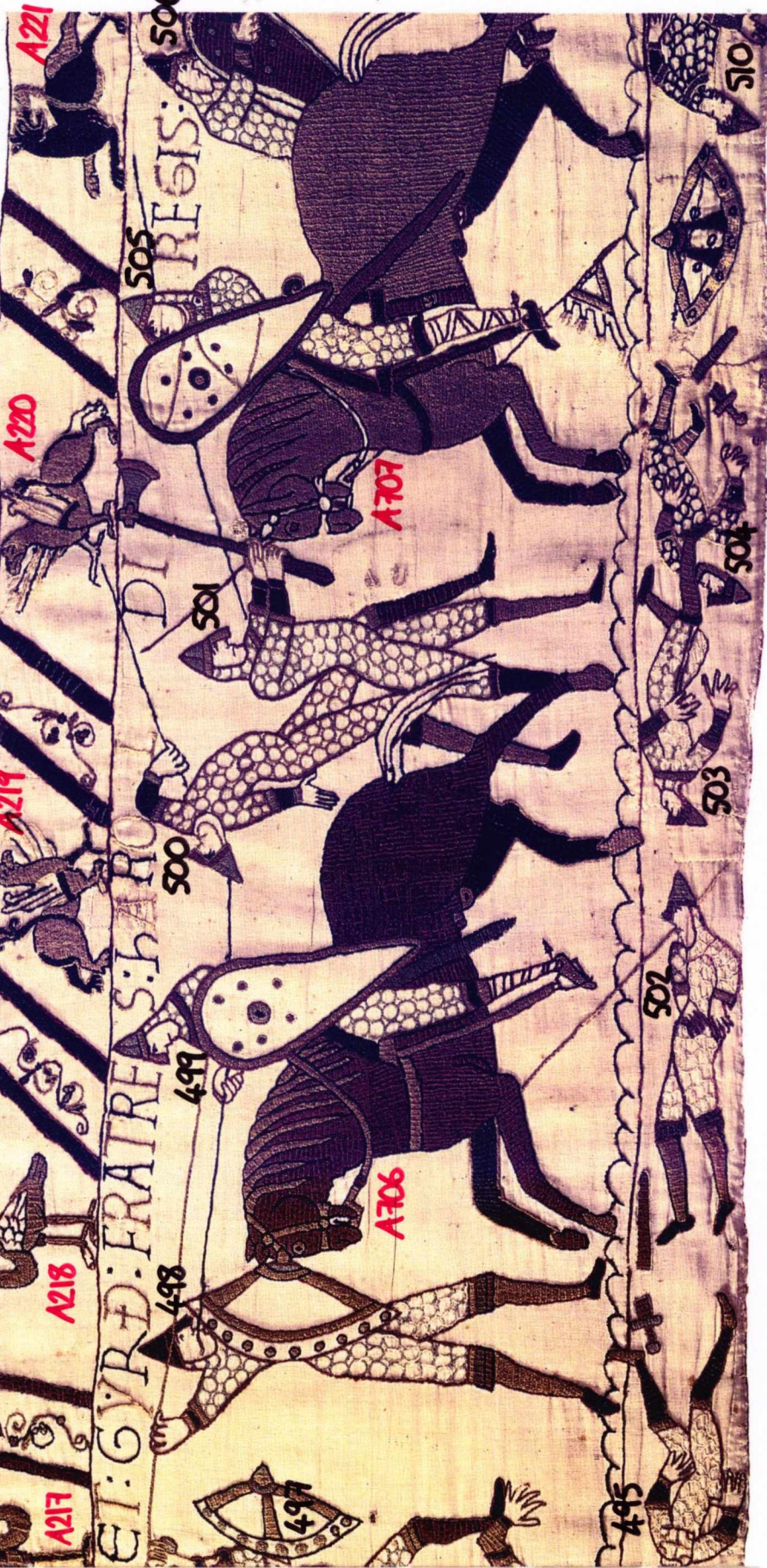

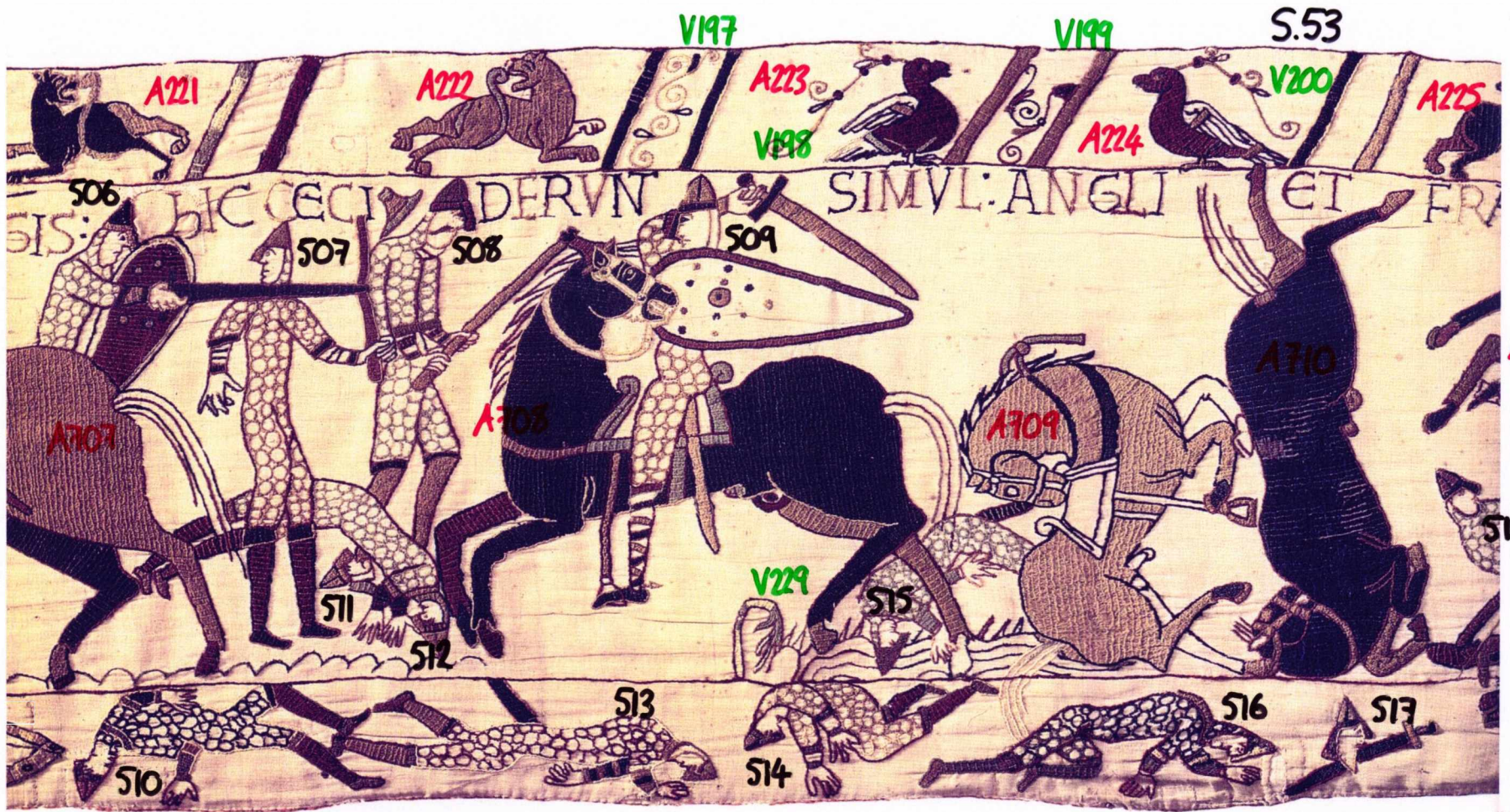

V201

A225

A226

V202

A227

V203

A228

V204

A229



518

S.54

V205

V204

A228

A229

A230

A231

V206

V207



526

A212

T22

533

534

535

536

539

540

528

532

A232

537

538

544

718

8 | E

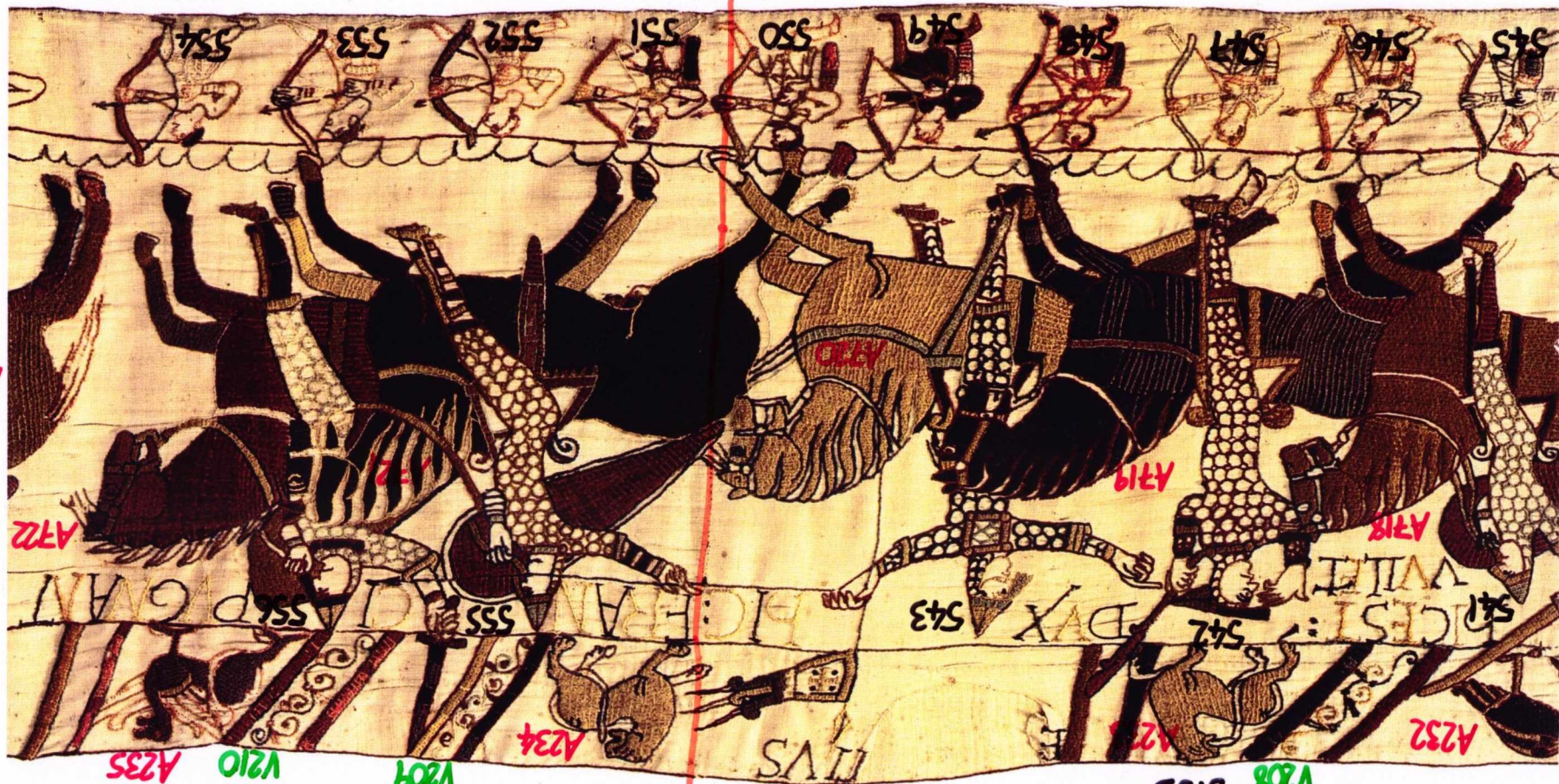

8 | E

V208 S.S

V210 A235

V209

A723

A722

A234

A232

A719

A718



V214

V215

V216

V217

V218





V218

V219

S.57

V220

V221

A245

A246

A247

A248

A249

HIC

BARO LE D: REX: INTERFEC TVS: EST

586

587

591

592

A778

585

593

598

599

584

585

594

595

604

581

589

596

595

597

965

