



Kent Academic Repository

Horne, Robert, Batchelor, John C., Taylor, Paul S., Balaban, E. and Casson, A.J. (2020) *Ultra-Low Power on Skin ECG using RFID Communication*. In: 2020 IEEE International Conference on Flexible and Printable Sensors and Systems (FLEPS). . pp. 1-4. IEEE ISBN 978-1-72815-278-3.

Downloaded from

<https://kar.kent.ac.uk/94861/> The University of Kent's Academic Repository KAR

The version of record is available from

<https://doi.org/10.1109/FLEPS49123.2020.9239500>

This document version

Author's Accepted Manuscript

DOI for this version

Licence for this version

UNSPECIFIED

Additional information

Versions of research works

Versions of Record

If this version is the version of record, it is the same as the published version available on the publisher's web site. Cite as the published version.

Author Accepted Manuscripts

If this document is identified as the Author Accepted Manuscript it is the version after peer review but before type setting, copy editing or publisher branding. Cite as Surname, Initial. (Year) 'Title of article'. To be published in *Title of Journal*, Volume and issue numbers [peer-reviewed accepted version]. Available at: DOI or URL (Accessed: date).

Enquiries

If you have questions about this document contact ResearchSupport@kent.ac.uk. Please include the URL of the record in KAR. If you believe that your, or a third party's rights have been compromised through this document please see our [Take Down policy](https://www.kent.ac.uk/guides/kar-the-kent-academic-repository#policies) (available from <https://www.kent.ac.uk/guides/kar-the-kent-academic-repository#policies>).

Ultra-Low Power on Skin ECG using RFID Communication

Robert Horne, John Batchelor and Paul Taylor
School of Engineering and Digital Arts
University of Kent,
Canterbury, UK
r.j.horne@kent.ac.uk

Ertan Balaban and Alex Casson
Department of Electrical and Electronic
Engineering, University of Manchester,
Manchester, UK
ertan.balaban@manchester.ac.uk

Abstract—Electrocardiograms provide rhythm, rate and electrical activity of the heart which can be used to diagnose health issues. Current methodologies for wireless based heart monitoring favour the use of Bluetooth Low Energy, which can require bulky batteries for device longevity. This paper investigates the use of a novel ultra-low power communications technique utilising Ultra High Frequency Radio Frequency Identification to stream ECG data in real time to a host computer to enable sub 2mW power consumption.

Index Terms—Radio Frequency Identification, Flexible Sensors, Wearable Sensors, Heart Rate, Electronic Skin

I. INTRODUCTION

The use of commercial Electrocardiograms (ECG) in consumer grade electronics has seen a major increase in the last 5 years[1] with the launch of devices such as the Fitbit[2] and the Apple watch[3]. These devices more commonly use a Photoplethysmogram sensor to provide a semi-accurate heart rate reading for sports and well being applications. More advanced systems employ a strap-based system which can utilise an ECG chip to monitor the heart[4]. Whilst the strap-based systems can provide higher levels of accuracy, they are not classed as medical devices and do not provide the same level of accuracy that multi channel ECG systems deliver. Clinical grade systems which are used within hospitals and medical facilities can have devices which use up to 12 channels for ECG monitoring, but are typically fully wired and bulky.

Wireless devices which incorporate a strap typically use Bluetooth Low Energy (BLE) and either coin cells or small lithium Polymer Batteries as a power source, communicating raw data to a processing point such as a mobile phone or exercise machine.

The methodology introduced in this paper challenges the typical communication technique by using Ultra High Frequency RFID in order to stream the data at a very low power level. UHF RFID has several distinct features which enable it to differentiate itself from other communications protocols such as BLE[5][6][7], for instance sub 1mW power consumption for a Battery Assisted Passive mode, lower cost per chip and ability to interface with existing inventory management systems. Near Field Communications (NFC) RFID has been used to stream ECG data[8], however the data transmission range is limiting at range of 5cm.

UHF RFID has been used in studies for streaming data off of the body, for example in the measurement of muscle signals using an electromyograph[9] and accelerometry[10] for body movement analysis.

II. SYSTEM METHODOLOGY

The system described in this paper can be broken down into several sections.

A. Physical Construction

The device in this paper was constructed on a 0.13mm thick Kapton substrate, which had a electroless nickel immersion gold plating. This substrate was chosen to enable it to conform to the surface of the chest, rather than having a rigid printed circuit board which would impact on the comfort of the wearer.

Standard clip electrodes were used to capture the ECG signals from the body. The printed circuit board was attached to the body with the electronics side facing up, with a thin silicon adhesive attaching it to the body.

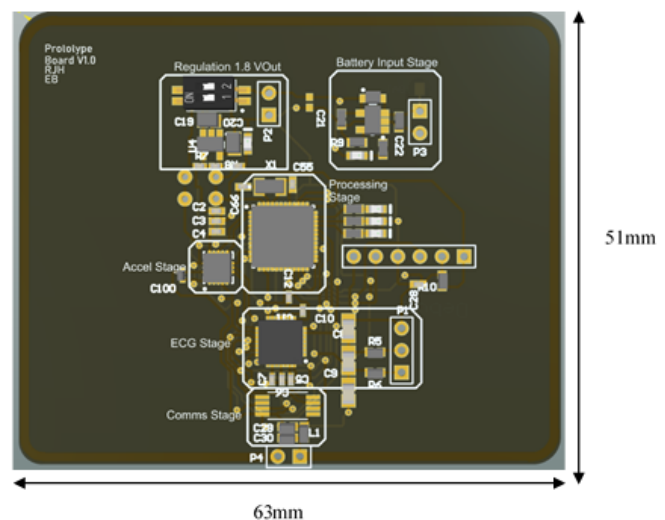

Fig. 1. Printed Circuit Board Layout

B. UHF Communications

To enable UHF RFID communications the EM4325[11] from EM microelectronic was used, as it had been previously used in streaming higher data rate body-centric data [10] and was shown to reliably stream accelerometer data. The EM4325 has two power modes for transmission, one which relies on the power harvested from the reader, and another which uses a small amount of power from an external battery (Battery Assisted Passive mode). For this investigation, BAP mode was used to boost the read performance of the communications stage. The antenna used for the design utilised a loop topology with a T matching network to enable an efficient interface to the EM4325. The design of the circuit was such that there would be sufficient spacing around the antenna edge to give the highest performance.

The UHF reader used in this system was the Jadak Thing-Magic M6E[12], the reader used a circular polarised antenna directed at the on the skin system, at 1.5 meters.

C. Electrocardiogram Measurement

To capture ECG wave forms the MAX30001[13] was selected due to its low power performance and small package. The chip requires minimal external circuitry which enabled the design to be compact in order to conform within the design specifications of the antenna.

D. Embedded Processing

To process the data and communicate between the ECG sensor and the communications chip, the Texas Instruments MSP430FR5969[14] microcontroller was used. This microcontroller is focused heavily on low power operation during wake states, whilst also providing extremely low power consumption during sleep states. The microcontroller uses a main SPI bus to interface all of the communicating devices, ensuring minimal signal traces. During peak operation the microcontroller uses upto 1.6 mA (at full speed), and can be cycled into a low power sleep mode which consumes 0.02µA.

E. Power Management

To power the design, a small lithium Polymer battery(120mAh) was employed, with a charging and regulation stage used. The charging stage was a MCP7381T-2ACI[15], which allowed for external power to be applied between the charge phase and regulation phase to replenish the battery. The regulation phase used a ADP1710[16] which regulated the voltage to a system wide 2V.

F. Systems Software

In order to transmit the data from the device, a packet scheme is required to format the data. In Fig.2. the packet scheme used is shown. The packet consists of three parts, a frame number which iterates every time a frame is sent, a payload and CRC for error analysis. The payload contains both the current value and the previous value, this is so that if a packet is lost, the frame can provide instant recovery of data. Frames can be missed every 4 seconds using UHF due to

cycling of channels required by the the EPC Gen 2 standard. To interface with the ThingMagic Reader, the Mercury Api[17] was used within a custom C sharp application.

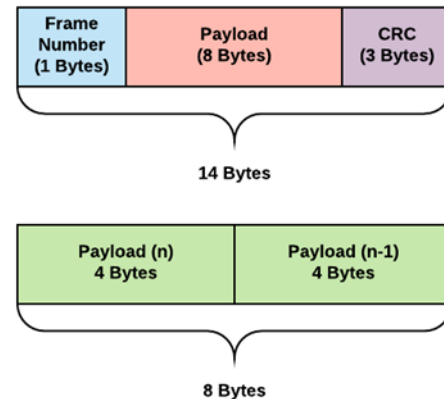

Fig. 2. Packet layout and breakdown

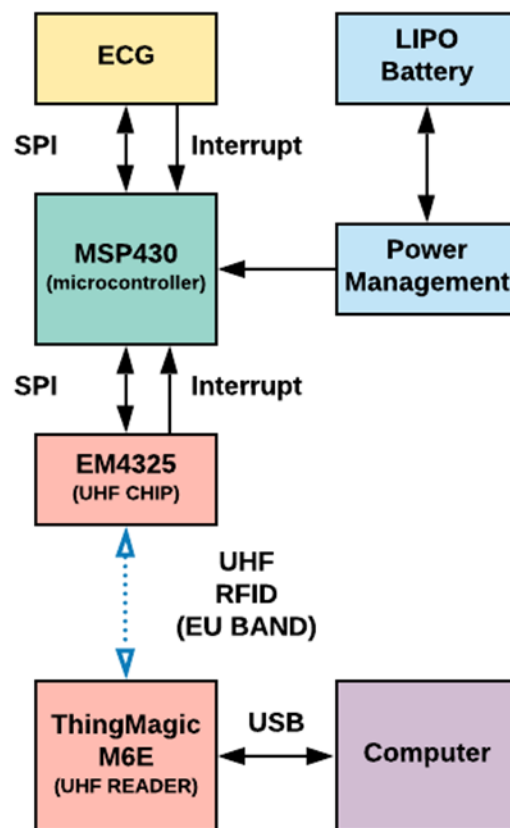

Fig. 3. System Block Diagram



Fig. 4. Device Printed Circuit Board

III. PRELIMINARY RESULTS

The system was tested by streaming the ECG data to a computer, which logged the real-time data into a .csv file. The test was done on a healthy participant at rest to evaluate whether a) Heart rate could be established b) whether waveform analysis could be done on the incoming signal enabling P,Q,R,S and T identification c) quality of the signal. The device was mounted as can be seen in Fig.5. and utilised battery power.

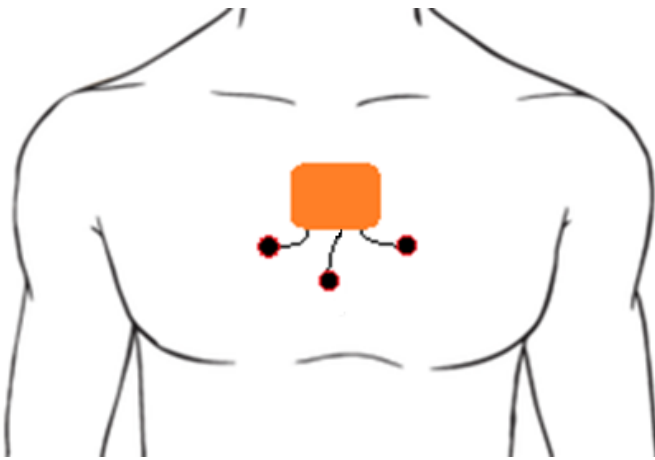



Fig. 5. Device Body Placement

As can be seen from Fig.6. the ECG waveform captured shows a very clean signal, with clear P,Q,R,S and T waves identifiable. The heart rate was determined by looking at R wave frequency, and had correlation with a finger based pulse oximeter. The power consumption of the device was recorded at 1.9  (950 μ A at 1.98V) while streaming data, which is higher than a calculated 1.4mW (693 μ A at 2.0v) from the data-sheets provided by the manufacturers, however this could be due to losses in the power stage. With the 120mAh battery included, the estimated active time for the device would be rated at over 120 hours or 5 days.

During testing the device remained attached to the participant and remained attached until the end of testing, the kapton

allowed for the design to flex during breathing allowing for no discomfort.

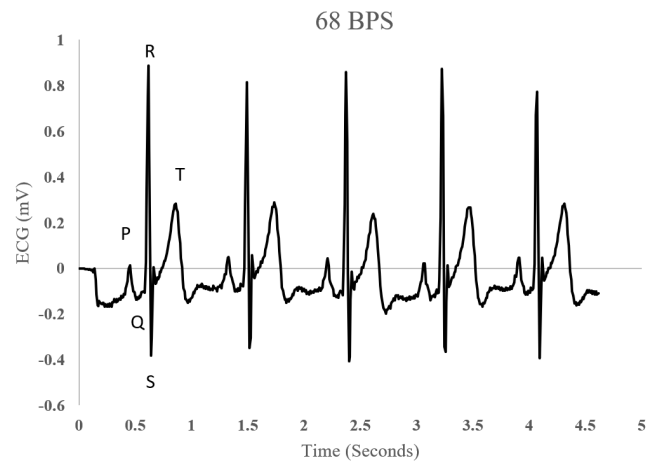

Fig. 6.  Waveform

IV. CONCLUSION

This paper outlines a novel system for capturing ECG signals from the body and transmitting them through UHF RFID enabling lower power data transmission than other methodologies currently provide. The systems performance shows that the communications technique chosen is able to transmit the data at a frequency and integrity which ensures that no data is lost in ideal conditions and that the power consumption is below 2mW.

Future developments of this technique will be to migrate the design onto a printed substrate, and integrate a thin film rechargeable battery to further improve the body conformity of the design. Furthermore, work into passively harvesting sufficient energy to power the entire device are being investigated.

ACKNOWLEDGMENT

This research was supported by the EPSRC projects Adaptive Assistive Rehabilitative Technology: Beyond the Clinic (AART-BC) (EP/M025543/1) and Formulating and Manufacturing Low Profile Integrated Batteries for Wireless Sensing Labels (EP/R02331X/1).

Testing procedures and methodology were impacted by the Novel Coronavirus 19 outbreak.

REFERENCES

- [1] A. Walinjar and J. Woods, "Personalized wearable systems for real-time eeg classification and healthcare interoperability: Real-time eeg classification and fhir interoperability," in *2017 Internet Technologies and Applications (ITA)*, 2017, pp. 9–14.
- [2] (2020) Fitbit. [Online]. Available: <https://www.fitbit.com/uk/home>
- [3] (2020) Apple. [Online]. Available: <https://www.apple.com/uk/watch/>
- [4] V. P. Rachim and W. Chung, "Wearable noncontact armband for mobile eeg monitoring system," *IEEE Transactions on Biomedical Circuits and Systems*, vol. 10, no. 6, pp. 1112–1118, 2016.
- [5] F. J. B. et al, "Epidermal tattoo potentiometric sodium sensors with wireless signal transduction for continuous non-invasive sweat monitoring," *Biosensors and Bioelectronics.*, vol. 54, pp. 603–609, 2014.

- [6] W. G. et al, "Fully integrated wearable sensor arrays for multiplexed in situ perspiration analysis," *Nature.*, vol. 529, pp. 509–514, 2016.
- [7] J. Li, M. Bhuiyan, X. Huang, B. McDonald, T. Farrell, and E. A. Clancy, "Reducing electric power consumption when transmitting ecg/emg/eeeg using a bluetooth low energy microcontroller†," in *2018 IEEE Signal Processing in Medicine and Biology Symposium (SPMB)*, 2018, pp. 1–3.
- [8] C. . Wu, W. . Kuo, H. . Wang, Y. . Huang, Y. . Chen, Y. . Chou, S. . Yu, and S. . Lu, "A pliable and batteryless real-time ecg monitoring system-in-a-patch," in *VLSI Design, Automation and Test(VLSI-DAT)*, 2015, pp. 1–4.
- [9] S. Nappi, V. Mazzaracchio, L. Fiore, F. Arduini, and G. Marrocco, "Flexible ph sensor for wireless monitoring of the human skin from the medimun distances," in *2019 IEEE International Conference on Flexible and Printable Sensors and Systems (FLEPS)*, 2019, pp. 1–3.
- [10] R. Horne, P. Jones, P. Taylor, J. Batchelor, and C. Holt, "An on body accelerometer system for streaming therapy data using cots uhf rfid," in *2019 IEEE International Conference on RFID Technology and Applications (RFID-TA)*, 2019, pp. 301–305.
- [11] (2020) Em4325 datasheet. [Online]. Available: <https://www.emmicroelectronic.com/sites/default/files/products/datasheets/4325>
- [12] (2020) JadaK thingmagic m6e. [Online]. Available: <https://www.jadatech.com/products/thingmagic-rfid/thingmagic-m6e-uhf-rain-rfid/>
- [13] (2020) Max30001 datasheet. [Online]. Available: <https://datasheets.maximintegrated.com/en/ds/MAX30001.pdf>
- [14] (2020) Msp430fr5969 datasheet. [Online]. Available: <https://www.ti.com/lit/ds/symlink/msp430fr5969.pdf?ts=1589243588794>
- [15] (2020) Mcp7381t-2aci datasheet. [Online]. Available: <http://ww1.microchip.com/downloads/en/DeviceDoc/20001984g.pdf>
- [16] (2020) Adp1710 datasheet. [Online]. Available: <https://www.analog.com/media/en/technical-documentation/datasheets/ADP17101711.pdf>
- [17] (2020) Mercury api. [Online]. Available: <https://www.jadatech.com/products/thingmagic-rfid/thingmagic-mercury-api/>