



# Kent Academic Repository

Zhu, Quanmin, Li, Ruobing and Yan, Xinggong (2021) *U-model-based double sliding mode control (UDSM-control) of nonlinear dynamic systems*. International Journal of Systems Science . ISSN 0020-7721.

## Downloaded from

<https://kar.kent.ac.uk/93160/> The University of Kent's Academic Repository KAR

## The version of record is available from

<https://doi.org/10.1080/00207721.2021.1991503>

## This document version

Publisher pdf

## DOI for this version

## Licence for this version

UNSPECIFIED

## Additional information

## Versions of research works

### Versions of Record

If this version is the version of record, it is the same as the published version available on the publisher's web site. Cite as the published version.

### Author Accepted Manuscripts

If this document is identified as the Author Accepted Manuscript it is the version after peer review but before type setting, copy editing or publisher branding. Cite as Surname, Initial. (Year) 'Title of article'. To be published in *Title of Journal*, Volume and issue numbers [peer-reviewed accepted version]. Available at: DOI or URL (Accessed: date).

## Enquiries

If you have questions about this document contact [ResearchSupport@kent.ac.uk](mailto:ResearchSupport@kent.ac.uk). Please include the URL of the record in KAR. If you believe that your, or a third party's rights have been compromised through this document please see our [Take Down policy](https://www.kent.ac.uk/guides/kar-the-kent-academic-repository#policies) (available from <https://www.kent.ac.uk/guides/kar-the-kent-academic-repository#policies>).



## U-model-based double sliding mode control ( $U_{DSM}$ -control) of nonlinear dynamic systems

Quanmin Zhu, Ruobing Li & Xinggang Yan

To cite this article: Quanmin Zhu, Ruobing Li & Xinggang Yan (2021): U-model-based double sliding mode control ( $U_{DSM}$ -control) of nonlinear dynamic systems, International Journal of Systems Science, DOI: [10.1080/00207721.2021.1991503](https://doi.org/10.1080/00207721.2021.1991503)

To link to this article: <https://doi.org/10.1080/00207721.2021.1991503>



© 2021 The Author(s). Published by Informa UK Limited, trading as Taylor & Francis Group



Published online: 12 Nov 2021.



Submit your article to this journal [↗](#)



Article views: 245



View related articles [↗](#)



View Crossmark data [↗](#)

# U-model-based double sliding mode control ( $U_{DSM}$ -control) of nonlinear dynamic systems

Quanmin Zhu<sup>a</sup>, Ruobing Li<sup>a</sup> and Xinggang Yan<sup>b</sup>

<sup>a</sup>Department of Engineering Design and Mathematics, University of the West of England, Bristol, UK; <sup>b</sup>School of Engineering and Digital Arts, University of Kent, Canterbury, UK

## ABSTRACT

This study proposes a double sliding mode control-augmented U-control ( $U_{DSM}$ -control) method for a class of single-input single-output nonlinear systems with internal uncertain parameters, model mismatching and external system noise/disturbance to improve robustness in nonlinear dynamic inversion in the U-control system design. For the configuration, the  $U_{DSM}$ -control system takes up (1) a double sliding mode dynamic inverter to cancel nonlinearities and dynamics of the plant, (2) a linear invariant controller, the other dynamic inverter of the specified whole desired system performance, so that the whole system dynamic inversion is split into two designs in double feedback loops. For using the framework, this study analyses the associated properties on (1) global stability, (2) double sliding from a switching control driving the states to a sliding band and an equivalent control driving the states to a sliding line and (3) robustness against uncertainties/disturbances and a potential data-driven prototype. To validate the developed control system, it selects bench test examples for simulation studies using Matlab/Simulink, which demonstrates the  $U_{DSM}$ -control in terms of accuracy, tracking, and robustness. The tests also present a step-by-step design procedure for potential applications.

## ARTICLE HISTORY

Received 7 March 2021  
Accepted 4 October 2021



## KEYWORDS

Dynamic inversion; nonlinear dynamic cancellation; U-model; U-model-based control (U-control); sliding mode control; double sliding mode control; robust control; simulation demonstrations

## 1. Introduction

Regarding the control system analysis and design, almost all designs are involved with inversion (dynamic inversion (DI)) for determining control input once a specified control performance is formulated, as a function of the control input, within a specified control system structure. Therefore, DI, in one way or other, is one of the kernel issues, particularly the DI in terms of nonlinear expressions (Slotine & Li, 1991) in the control system design. The other issue with DI is whether it could be decomposed into a few simple DIs to reduce the computational complexity and remove unnecessary repeatability, such as in most of the classical linear controller designs, the whole DI for controller output in terms of Laplace transform is a product of two DIs (plant transfer function DI multiplied by a closed-loop transfer function DI). For those designed nonlinear controllers, it is not such easy to split systematically the whole DI to resolve the control input (controller outputs).

DI, particularly nonlinear DI (NDI), approach has widely used in the flight control system design (Miller, 2011). Many approaches have taken to plant nonlinearity cancellation into a controllable equivalent linear dynamic by feedback linearisations (Horn, 2019; X. Wang et al., 2019), and then design the corresponding control system. Although the DI concept provides concise control system design frameworks, the perfectly matched idealised assumption of the model was a challenge for applications and academic research. Consequently, various methods have been involved to improve the robustness of DI. Adaptive approaches (Miller, 2011) are definite options of the solutions, but our study is not interested in this. Accordingly, this study will focus on the robust approaches in dealing with model uncertainties/disturbance and the induced problems in the formulations of the NDI-based control system design. Some of the developed approaches, representatively NDI approaches (Das et al., 2009), have used two steps of design (1) taking feedback

**CONTACT** Quanmin Zhu  Ruobing2.Li@live.uwe.ac.uk  Department of Engineering Design and Mathematics, University of the West of England, Frenchy Campus, Coldharbour Lane, Bristol BS16 1QY, UK

linearisation to transform the nonlinear state equations into an equivalent linear dynamic and (2) using linear control approaches to design the whole control systems. The robustness in NDI is not directly considered by the approaches, but it is alternatively accommodated in the external control loop design, in which the uncertainties might propagate to increase additional efforts in control. Incremental NDI (INDI) (Sieberling et al., 2010; Tarokh, 2017) is a technique that does not use required input to control the system. Alternatively, it takes the required change in the input. Therefore, the INDI only uses a small part of the model in DI, so that it can cope better with model inaccuracies and more robust than NDI. Two commonly shared characteristics with NDI and INDI are feedback linearisation and limited with affine nonlinear models, respectively. Sliding mode control-based NDI (SMCNDI) (Yang et al., 2014) uses two loops: an inner loop for NDI with typical SMC and an external loop for assigning the control system performance in positioning and tracking. The unmatched model uncertainty is accommodated in the inner loop. The affine nonlinear model (linear in control) was assumed in designing equivalent control in the SMCNDI. Eigenvalue assignment-based NDI (Y. C. Wang et al., 2015) is not necessary to convert the nonlinear state-space models into linear equivalent expressions by feedback linearisation before designing the control systems. The approach also can cope with non-affine and non-minimum phase systems, if the eigenvalues of error dynamics are properly selected to keep the desired dynamics stable. However, it is still an approach cancelling nonlinearities instead of cancelling dynamics and nonlinearities.

From the NDI control system design methods, U-model-based control (Zhang, Zhu et al., 2020; Zhu & Guo, 2002), U-control in short, has been proposed to cover the two essential tasks: establishing a universal NDI platform to remove the pre-requirement of the state feedback linearisation and configuring the control system framework to decompose the whole NDI for the solution of controller output into two parallel DIs, that is DI of control system performance to form an external linear feedback control loop and DI of the plant to cancel both the plant dynamics and nonlinearities into a unite constant. There have been two-stage developments with U-control. *Stage 1* – model-matched control (focus on dynamic model inversion and control

system configuration) integrates with classical control approaches to expand the feasibility and effectiveness dealing with nonlinear dynamics such as U-pole placement control (Zhu & Guo, 2002), U-internal model control (Shafiq & Haseebuddin, 2005), U-general predictive control (Du et al., 2012), U-model enhanced Smith predictive control (Geng et al., 2019), U-neural network-based control (Zhu et al., 2019), U-model-based Multi-Input Multi-Output (MIMO) control of unmanned marine robotics (Hussain et al., 2019). A recent SI, from complexity to simplicity in the U-model enhanced control system design, covers more U-control studies (Zhu et al., 2020). U-control is complemented to many existing control system design approaches.

The model-matched U-control is a foundation; however, the model-matched assumption should be removed for academic research challenges and real applications, so that robust and/or adaptive control should take internal model mismatching (structural and parametric uncertainties) and external disturbance and taking measuring noise into consideration in the control system design. With the justifications aforementioned, *Stage 2* – U-control has taken model mismatched (focus on robust DI and control system configuration) into consideration in such control system designs. Here some of the representative approaches are explained for reference such as Newton Raphson online iterative root solving algorithm for NDI (Zhu & Guo, 2002), neural network learning for NDI (Hussain et al., 2019), adaptive NDI (Zhu et al., 2018), extended state observer-based NDI (Wei et al., 2020). The approaches have relied on the small gain theorem in the aspect of robustness. Surely more research is needed for NDI (probably, nonlinear dynamic cancellation (NDC) is more proper) while removing both nonlinearities and dynamics of a plant simultaneously in conjunction with U-control should be explored to give more effective options for a wide range of nonlinear control system designs, which the U-control is a scheme of seamless supplement to many existing control methods.

From the above review, some aspects that could be further improved in NDI-based control system configuration and NDI-solving algorithms are as follows:

- (1) In most of the NDI control system designs, the models used have been affined in the controller input, which, because of nonlinear control input,

is still a linear inversion problem. Nonaffine plant models should have been properly accommodated in NDI for research and applications.

- (2) In the case of the model matched and the other mild conditions satisfied, feedback linearisation might not be needed. Direct dynamic/nonlinearity cancellation could be resolved in an open-loop approach within an external feedback control loop.
- (3) For some state space models, such as rational state space models (control input could be in the denominator), feedback linearisation is probably more challenging than NDI (Zhu et al., 2018).
- (4) In the case of the model matched, DI could be generally treated as a polynomial root-solving process for polynomial models, rational (total nonlinear) models (Zhu et al., 2015) and state-space models.
- (5) Regarding robust DI, sliding mode control (SMC)-based inverters should be further studied, which should have low sensitivity to plant parameter uncertainty and promising strength against external disturbance and fast convergence.

### 1.1. The major contributions of the study

To deal with systems subject to structural/parametric uncertainties due to the modelling error, and external noise/disturbances, SMC has proved/demonstrated its robustness in performance and conciseness in design (Yan et al., 2017). SMC has grown rapidly as a control in comparison with other robust control strategies due to the distinguishing features such as insensitiveness to matched uncertainties, reduced-order sliding mode (SM) equations, zero error convergence of the closed-loop system and it offers a nonlinear control. This study aims to use basic SMC to enhance NDI/NDC to establish a general robust U-control framework. The main contributions are listed as follows:

- (1) Propose a double sliding mode control (DSMC) scheme to establish a robust dynamic inverter, to cancel the plant nonlinearities and dynamics, which removes the request of plant nominal model and eliminates chattering in the classical SMC design. Lyapunov stability is used for determining the switching control and equivalent control in the sliding mode inverter (SMI). In essence, this provides a data-driven prototype
- (2) Establish a  $U_{DSM}$ -control system design platform: in brief, it takes two separate DIs in the whole control system design. For a specified linear system performance (using damping ratio and undamped natural frequency), design a close loop with an invariant controller to implement; the invariant controller is the inverse of the specified system performance. The design is independent of the plant and provides the desired state vector for the reference of the DSMC operation in the inner loop. Secondly, design an inner loop with DSMC to achieve robust plant DI.
- (3) Present bench tests with computational experiments (Matlab/Simulink based) to validate the analytical results and function block connections. Also, the tests provide a user-transparent design procedure for future research expansion and applications.

Section 2 explains the principles and framework of the model-matched U-control in stage 1 U-control, which lays a foundation to develop a model-mismatched U-control. Section 3 proposes a double SM controller to act as a plant dynamic robust inverter to cancel nonlinearities and dynamics. Then this makes the stage 1 U-control framework applicable to specify the whole system performance. The section also analyses the associated properties with the second stage U-control. Section 4 conducts the bench tests to validate the derived results with Matlab/Simulink. Section 5 summarises the study with findings and observations and gives a view of potential research issues.

## 2. Model matched U-control

The U-model-based control involves two aspects: U-model and U-control system design.

### 2.1. U-models

A general single-input single-output U-polynomial model of  $P$  (Zhu et al., 2018), mapping  $u \rightarrow y$ , with a triplet of  $(y(t), u(t), \alpha(t))$ ,  $y(t) \in \mathbb{R}, u(t) \in \mathbb{R}, \alpha(t) \in \mathbb{R}^J$  for the output, input and time-varying parameter vector, respectively, at time  $t \in \mathbb{R}^+$ , is defined for

describing dynamic plants as

$$y^{(M)} = \mathcal{A}^T \mathcal{U} = \sum_{j=0}^J \alpha_j f_j(u^{(N)}), \quad M \geq N \quad (2.1)$$

where  $y^{(M)}$  and  $u^{(N)}$  are the  $M$ th and  $N$ th order derivatives of the plant output  $y$  and input  $u$ , respectively.  $J \in \mathbb{R}^+$  is the number of the polynomial terms. The time-varying parameter  $\alpha_j \in \mathbb{R}$  is an absorbing function to include the other outputs like  $[y^{(M-1)}, \dots, y] \in \mathbb{R}^M$  and inputs  $[u^{(N-1)}, \dots, u] \in \mathbb{R}^N$ .  $f_j(\cdot)$  is a function of the input  $u^{(N)}$ . Vectors  $\mathcal{A}^T = [\alpha_0, \dots, \alpha_J]$  and  $\mathcal{U} = [f_0, \dots, f_J]^T$  over a field  $F$ ,  $F \times F \rightarrow F$ , are the operators mapping the underlying input, output and parameters into the condensed expressions.

To illustrate the U-representation of classical models, consider a general polynomial model of

$$\begin{aligned} \ddot{y} &= (1 - e^{-\sin^2(y)})\dot{y} + (1 + y^2) \sin(u) \\ &+ (1 + \dot{y}^2)u^2 + y + (y + \dot{y}^2)u^3 \end{aligned} \quad (2.2)$$

Its U-model is transformed with the U-mappings of  $\mathcal{A}$  and  $\mathcal{U}$  into

$$\left\{ \begin{array}{l} \ddot{y} = \alpha_0 f_0(u) + \alpha_1 f_1(u) + \alpha_2 f_2(u)^2 + \alpha_3 f_3(u)^3 \\ \alpha_0 = (1 - e^{-\sin^2(y)})\dot{y} + y, \quad f_0(u^0) = 1 \\ \alpha_1 = 1 + y^2, \quad f_1(u) = \sin(u) \\ \alpha_2 = 1 + \dot{y}^2, \quad f_2(u^2) = u^2 \\ \alpha_3 = y + \dot{y}^2, \quad f_3(u^3) = u^3 \end{array} \right. \quad (2.3)$$

*Remark 1:* U-model represents the existing model sets with a directly control-oriented structure. U-polynomial is the foundation to expand the whole U-model set. For the representation to classical linear models, assign  $J = 1$ , functions  $f_0(u) = 1$ ,  $f_1(u) = u$ , then the linear U-model takes the following form  $y^{(M)} = \alpha_0 + \alpha_1 u^{(N)}$ ,  $M \geq N$  (2.4)

For representing the conventional state space model set, the U-state space model set expands the single-layer U-polynomial model (2.11) into multi-layer systems of polynomials (Geng et al., 2019).

For representing the conventional rational (total nonlinear) model set (Zhu et al., 2015), U-polynomial is expanded into a ratio of U-numerator polynomial and U-denominator polynomial (Zhu et al., 2018).

## 2.2. U-model-based dynamic inversion

Let U-model  $P$ , in the form of a polynomial, be a mapping/function,  $u \rightarrow y$ . The U-model-based dynamic inversion (UM-DI) algorithm, that is the solution of its inverse  $P^{-1}$ , is to obtain the input  $u$  by solving (2.1) for a given output,

$$\begin{aligned} P^{-1} \Leftrightarrow u^{(N)} \in y^{(M)} - \sum_{j=0}^J \alpha_j f_j(u^{(N)j}) = 0, \\ M \geq N \end{aligned} \quad (2.5)$$

If solution exist, the systems must be bounded input and bounded output (BIBO) stable and no unstable zero dynamic (non-minimum phase). The solution platform has been expanded including the root solving algorithms for continuous/discrete time, linear/nonlinear, polynomial/state space models (Li et al., 2020).

*Remark 2:* Compared with the model-matched DI, most of the other DI approaches use state or output feedback linearisation, which only cancels nonlinearities. The UM-DI, in the open-loop approach, directly works out the solutions/control input by solving U-model polynomial equations with specified desired outputs, which cancels nonlinearities and dynamics. It is more concise and generally applicable.

## 2.3. U-control

Let  $P$  be a general representation in any model of linear/nonlinear and polynomial/state-space models for dynamic plants. Assumingly, the set of the plants has most of the properties as those claimed in the other representative works (Isidori, 2013). Accordingly,

- (1) the model inverse  $P^{-1}$  exists;
- (2) Lipschitz continuity is satisfied, the model  $P$  is a mapping/function,  $u \rightarrow y$ , and its inverse  $P^{-1}$  are diffeomorphic and globally uniformly Lipschitz in  $\mathbb{R}$ ; that is,

$$\begin{aligned} \|P(u_1) - P(u_2)\| &\leq \gamma_1 P \|u_1 - u_2\|, \\ \forall u_1, u_2 &\in \mathbb{R} \end{aligned}$$

$$\begin{aligned} \|P^{-1}(u_1) - P^{-1}(u_2)\| &\leq \gamma_2 P^{-1} \|u_1 - u_2\|, \\ \forall u_1, u_2 &\in \mathbb{R} \end{aligned}$$

where  $u_1, u_2$  are the inputs, while  $P$  is in the form of a polynomial model and replaced with states  $x_1, x_2$ ,



while  $P$  is in the form of state space equation,  $\gamma_1$  and  $\gamma_2$  are the Lipschitz coefficients.

The U-control system is functionally expressed as

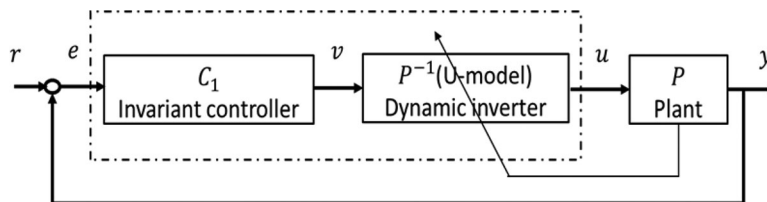
$$\Sigma = (\mathcal{F}, \mathcal{C}(C_1, P^{-1}), P) \Leftrightarrow \Sigma = (\mathcal{F}, C_1, I_{ip}) \quad (2.6)$$

where  $\mathcal{F}$  is the U-control system structure,  $\mathcal{C}(\ast)$  is a set to be designed controllers and  $I_{ip} = P^{-1}P$  is a unit constant. Figure 1 shows the model-matched U-control system framework (Zhang, Zhu et al., 2020), in which  $C_1$  is the linear invariant controller to be designed and  $P^{-1}$  is the inverter of the controlled plant  $P$  to be designed. It is noted that the U-control framework is applied to linear and nonlinear plants, while the dynamic inverse  $P^{-1}$  exists.

In general, the U-control system design procedure has two steps:

- (1) Design dynamic inverter  $P^{-1}$  to achieve  $I_{ip} = P^{-1}P = 1$ . This gives  $\Sigma = (\mathcal{F}, C_1)$ .
- (2) Design invariant controller  $C_1$  under  $\Sigma = (\mathcal{F}, C_1, I_{ip})$  with a specified closed loop linear transfer function  $G$ . This can be achieved in a typical formulation of linear control systems. For example, consider a second-order linear system, let the desired closed-loop transfer function  $G = \frac{\omega_n^2}{s^2 + 2\omega_n s + \omega_n^2}$ , where damping ratio and undamped natural frequency  $\omega_n$  can specify the system dynamic/steady-state response. As  $G = \frac{C_1}{1+C_1}$ , taking the inversion gives  $C_1 = \frac{G}{1-G}$ .

*Remark 3:* Regarding the robustness in U-DI for mismatched models, Newton–Raphson iterative, adaptive neural network leaning and the direct equation solution, it is noted that the small gain theorem has been used to specify the robustness, which is limited in a small range of uncertainty. To increase the DI robustness, it is believed that the feedback control loop should be added to regulate the DI errors properly.



**Figure 1.** Model matched U-control system framework.

### 3. Model-mismatched U-control

#### 3.1. Control system structure

To accommodate mismatched plant model and external disturbance, Figure 2 proposes a model-mismatched U-control system structure and is expressed functionally as follows:

$$\Sigma = (\mathcal{F}, \mathcal{C}(C_1, \hat{P}^{-1}), P) \Leftrightarrow \Sigma = (\mathcal{F}, C_1, \hat{I}_{ip}) \quad (3.1)$$

where  $\mathcal{F}$  is the U-control system structure,  $\mathcal{C}(\ast)$  is a controller set to be designed,  $C_1$  is a linear invariant controller to specify the external loop performance and  $\hat{P}^{-1}$  is a controller for DI with mismatched plant model to achieve  $\hat{I}_{ip} = I_n$  which is a  $n$ th order identity matrix.

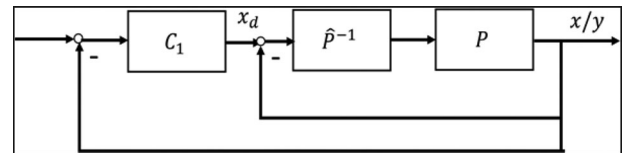
From the feedback-based DI in the inner loop shown in Figure 2, it is clear that the system output  $x$  is dependent on  $\hat{P}^{-1}$ ,  $P$  and  $x_d$ . For convenience, let the DI control system be

$$x = K_i(\hat{P}^{-1}, P, x_d) \quad (3.2)$$

where  $x$  is the output and  $x_d$  is the desired reference. The control objective is to achieve  $x = x_d$ , by designing an appropriate  $K_i(\cdot)$  and  $\hat{P}^{-1}$  for a given reference signal  $x_d$ . Accordingly, the inner loop has the property of  $\hat{I}_{ip} = I_n$ , which is a  $n$ th order identity matrix.

*Proposition:*  $\hat{I}_{ip} = I_n \rightarrow x - x_d = 0_n \Leftrightarrow x = x_d$ .

*Remark 4:* To still achieve the similar control target, as described in stage 1 (model matched U-control), the critical technical challenge is how to obtain  $\hat{I}_{ip} = I_n$ ,  $t > t_1$ . As SMC shows strong robustness in performance, fast response and conciseness in design, this study presents a scheme using SMC for DI called SMI.



**Figure 2.** Model mismatched U-control system framework.

### 3.2. DSMC design procedure for DI

This section presents a scheme using SMC to derive a robust dynamic inverter  $\hat{P}^{-1}$  to achieve  $\hat{I}_{ip} = I_n$ ,  $t_1 \leq t$ . A widely used SMC approach (Yan et al., 2017) is referred to formulate the dynamic inverter with  $u = u_{eq} + u_{sw}$  which is a prototype of combing equivalent input  $u_{eq}$  and switching input  $u_{sw}$ . Once the sliding surface is determined, then the SMI can be obtained in a revised SMC formulation. Accordingly, the study proposes a DSMC method, a global SM band with interval  $\delta$  to drive errors into and remain in the stable interval, a local SM line to attract the error within the stable interval towards zero exponentially monotonically. Figure 3 (part of the figure from Yang et al., 2014) shows the double sliding surface against the classical one.

The DMSC design procedure is explained as follows.

- (1) Design a global sliding surface  $S_g$  to specify the considered system with a desired performance once the system remains on the SM. Realistically, a small interval (boundary)  $\delta$  is assigned for the distance to the classical sliding surface  $S$ . So  $S_g$  presents a sliding band surface with thickness  $\delta$ .

Let  $X = [x, \dot{x} \dots x^{(n-1)}]$ , then define an  $(n-1)$ th order of state tracking error vector

$$E = X - X_d = [e = x - x_d \quad \dot{e} = \dot{x} - \dot{x}_d \quad \dots]$$

$$e^{(n-1)} = x^{(n-1)} - x_d^{(n-1)} \Big]^T \quad (3.3)$$

where  $x^{(i)}$  and  $x_d^{(i)}$  are the  $i$ th order derivatives of the plant model state  $x_1$  and desired state  $x_d$ , respectively. Then set up a classical sliding surface function  $S$  (Yan et al., 2017) in the form of

$$S = c_1 e + c_2 \dot{e} + \dots + c_{n-2} e^{(n-2)} + e^{(n-1)} \quad (3.4)$$

where the coefficient vector  $C = [c_1 \quad c_2 \quad \dots \quad c_{n-2}] \in \mathbb{R}_{\geq 0}$  is chosen in terms of Hurwitz stable.

Then the global sliding surface with the boundary  $\delta$  in the SM interval is designed as

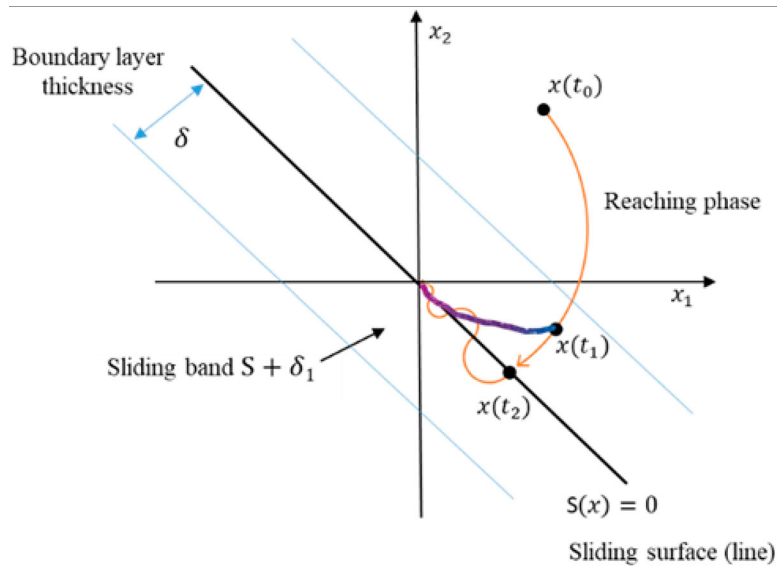
$$S_g = S + \delta_1, \quad 0 \leq |\delta_1| \leq |\delta| \quad (3.5)$$

- (1) Design a switching controller  $u_{sw}$  to drive the system states to the sliding surface (interval/band) in finite time and keep the system state motion on the surface thereafter.

Assigning a Lyapunov function  $V_g = \frac{1}{2}(S_g)^2 = \frac{1}{2}(S + \delta_1)^2$  and the corresponding derivative is given by  $\dot{V}_g = \dot{S}_g S_g = \dot{S}(S + \delta_1)$ . Let  $\dot{S} = f_g + u_{sw}$ , where  $f_g$  represents all the neglected bounded terms in a classical SMC design.

The derivative of the Lyapunov function gives

$$\dot{V}_g = \dot{S}(S + \delta_1) = (f_g + u_{sw})(S + \delta_1) \quad (3.6)$$



**Figure 3.** System states (Red for classical SMC and Red + Blue for DSMC).



To satisfy  $\dot{V}_g \leq 0$  for stability, choose

$$u_{sw} = -k_g \text{sgn}(S + \delta_1) \quad (3.7)$$

where  $k_g \in \mathbb{R}_{>0} > |f_g|$  is a positive gain of the design choice and  $\text{sgn}(\ast)$  is the sign function.

- (1) Design a local sliding surface  $S_l$  an equivalent controller  $u_{eq}$  with the condition of driving the system state motion towards  $\dot{S}_l = 0$   $S_l = 0$  asymptotically.

For the local sliding surface, assign it as the classical Hurwitz stable manifold of (3.2), that is

$$S_l = S \quad (3.8)$$

Assigning a Lyapunov function  $V_l = \frac{1}{2}(S)^2$  and the corresponding derivative is given by  $\dot{V}_l = \dot{S}S$ . Let

$$\dot{S} = f_l + u_{eq} = k_2 S + u_{eq} \quad (3.9)$$

where  $f_l$  represents all neglected bounded terms in a classical SMC design. Let the matching condition of  $f_l = k_2 S$  be satisfied, where  $k_2$  is a bounded unknown tangent factor of  $S$ . To derive the equivalent controller  $u_{eq}$  satisfying the Lyapunov stability conditions of  $V_l \geq 0$   $\dot{V}_l \leq 0$ , expand the derivative of the Lyapunov function as

$$\dot{V}_l = \dot{S}S = (f_l + u_{eq})S = (k_2 S + u_{eq})S \quad (3.10)$$

To satisfy  $\dot{V}_l \leq 0$ , choose

$$u_{eq} = -k_l S, \quad k_l \in \mathbb{R}_{>0} > |k_2| \quad (3.11)$$

- (1) Finally, the double SM controller is formulated as  $u = u_{eq} + u_{sw}$

### 3.3. DMSC and U-control properties

P1: *Theorem 1:* Assume the plant is BIBO and its inverse exists, the DSMC is globally stable and make  $\hat{I}_{ip} = K_i(\hat{P}^{-1}, P) = 1, t_1 \leq t$  asymptotically. The DSMC design procedure is a process of proof. The first Lyapunov stability ( $V_g \geq 0$   $\dot{V}_g \leq 0$ ) used is to force the state vector  $X$  converge to the SM band  $S_g = S + \delta_1, 0 \leq |\delta_1| \leq |\delta|$  by switching control. The second Lyapunov stability ( $V_l \geq 0$   $\dot{V}_l \leq 0$ ) used is to force

the state vector  $X$  in the SM band converge asymptotically to the final SM line  $S_l = S + \delta_1 = S, \delta_1 = 0$  by continuous equivalent control. Therefore,  $X - X_d = 0 \Leftrightarrow \hat{I}_{ip} = K_i(\hat{P}^{-1}, P) = 1$ .

*Corollary:* If  $\hat{I}_{ip} = K_i(\hat{P}^{-1}, P) = 1$  asymptotically and the linear invariant controller  $C_1$  is Hurwitz stable, the U-control system is also Hurwitz stable. This is because  $G = \frac{C_1}{1+C_1}$ .

P2: Robustness is related to  $k_g \in \mathbb{R}_{>0} > |f_g|$  and  $k_l \in \mathbb{R}_{>0} > |k_2|$ , in which  $|f_g|$  and  $|k_2|$  give the bounds of the robustness in the switching control and equivalent control, respectively for the entire U-control systems.

P3: Sliding surface with the best-conditioned linear dynamics (Slotine & Li, 1991) can be selected with the U-control framework, by assigning damping ratio and undamped natural frequency within an external feedback loop, as explained in Section 2.3.

P4: In essence, the DSMC is a prototype of data-driven SMC to make the DI in the model free form. There is no need for knowing plant model structure and parameters under those commonly used assumptions with BIBO, inverse exit and plant dynamic order known. Compared with conventional data-driven approaches (Hou & Wang, 2013), the DSMC is in a style of data-driven design/operation, but does not require iterations to determine parameters. This type of data-driven control dramatically reduces the complexity in dealing with models in the SMC system design, for example, those derivations of equivalent control, which is effective for general variable structure systems. The bounds of  $|f_g|$  and  $|k_2|$  are necessary known in advance. The gains can conservatively be large enough to satisfy the conditions  $k_g \in \mathbb{R}_{>0} > |f_g|$  and  $k_l \in \mathbb{R}_{>0} > |k_2|$ .

P5: Compared with classical SMC, the DSMC is (1) not required to use a nominal model to design  $u_{eq}$ ; (2) to remove chattering, the local SM  $S_l$  shares the properties with low-pass filters (Slotine & Li, 1991); (3) regarding classical SMC, in general, the small sliding layer  $\delta$  is for better control accuracy, for stimulating chattering easily. Large  $\delta$  reduces the chattering, but increases steady-state errors possibly. The other factor is the gain associated with the switching control. It is larger for more control accuracy and faster to the sliding surface, but its amplitude is limited by the saturation of system input, particularly in applications. Both are normally selected by trial and error. For the DSMC, both factors are also vital for the control system

performance, but more relaxed in selection than those with SMC.

P6: Compared with SMCNDI (Yang et al., 2014), the DMSC includes the SMCNDI as it's a special case while using the nominal model to design equivalent control.

P7: Compared with high gain control (HGC) (Lin, 2009), the DMSC includes HGC as it's a special case while assigning the sliding surface boundary  $|\delta| > \max(|u|, |y|)$  and  $k_l \gg 0$ . The DMSC can achieve similar results using lower gain of  $k_l$  in conjunction with  $k_g$ .

P8: The  $U_{DSM}$ -control could be used to facilitate the requirement on the time scale separation (Chakraborty & Arcak, 2009) in the control system design because the framework separates the designs of inner control loop (dynamic inverter) and outer control loop (invariant controller).

#### 4. Case studies

Two case studies are selected for demonstrating the validity and comparisons of the derived procedure and block function connections of the control system configuration. The second purpose of the demonstrations is to show the design procedures and knowhow for the potential reference of applications and academic research.

*Plants:* The two exemplary plants, expressed in the model of  $\dot{X} = F(X, u)$ ,  $y = x_1 + d(t)$ , are (1) second-order ( $X = [x_1 \ x_2]^T$ ) dynamics with an external disturbance  $d(t) = 1$  added at the outputs, (2) the

dynamic order = 2 known and all the state variables accessible for the control system design, (3) BIBO and dynamic inverse exist and (4) no pure time delay.

$U_{DSM}$ -control: Figure 4 shows the control system structure to facilitate the explanation of the design procedure. For the two case studies, the design takes two separate tasks: (1) designing the SMI with the inner loop ( $x = K_i(\hat{P}^{-1}, P, x_d)$ ) to achieve  $\hat{I}_{ip} = I_2$  and (2) designing the invariant controller with the external loop to achieve the whole system performance. *For designing the SMI:* Define a tracking error vector as

$$\begin{aligned} E &= X - X_d = [e_1 = x_1 - x_{d1} \quad \dot{e}_1 = \dot{x}_1 - \dot{x}_{d1}]^T \\ &= [e_1 = x_1 - x_{d1} \quad \dot{e}_1 = x_2 - x_{d2}]^T \end{aligned} \quad (4.1)$$

Then set up a classical sliding surface function  $S$  as

$$S = ce_1 + \dot{e}_1 \quad (4.2)$$

where coefficient  $c = 20$  is chosen in terms of the Hurwitz stability criterion and a fast inner-loop convergence speed.

With reference to Section 3.2, of the SMI, having  $u_{sw} = -k_g \text{sgn}(S + \delta_1)$  and  $u_{eq} = -k_l S$ , this experiment, by trial and error, assigns  $k_g = 6$  and  $k_l = 5$ . Consequently, the integrated controller of the DSMC system is formulated as  $u = u_{eq} + u_{sw} = -6\text{sgn}(S + \delta_1) - 5S$ . Assign the sliding band boundary thickness  $|\delta| = 0.8$ .

*For designing the second-order IC:* Specify the whole desired closed loop control system performance with a linear second-order transfer function  $G =$

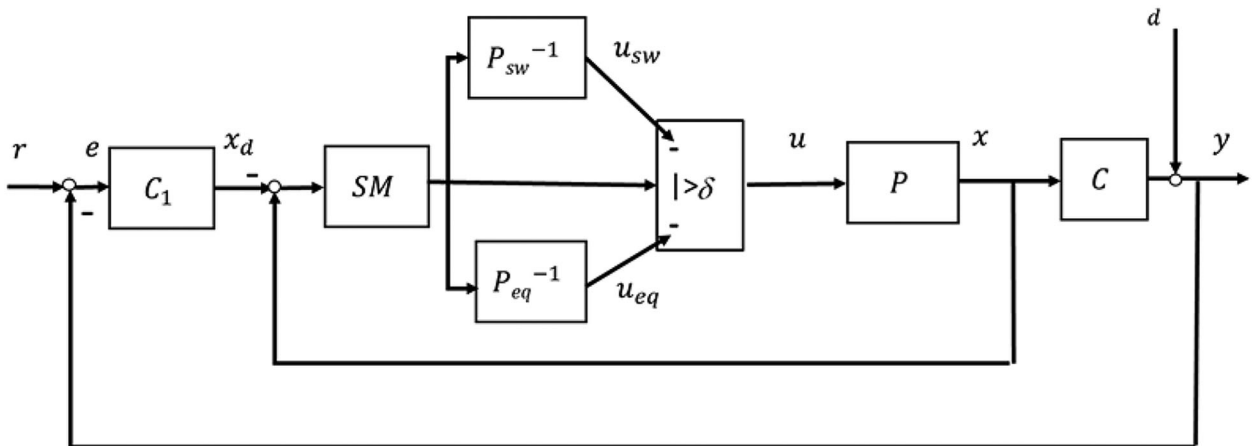


Figure 4.  $U_{DSM}$ -control system.

$\frac{C_1}{1+C_1} = \frac{\omega_n^2}{s^2+2\omega_n s+\omega_n^2}$ , where  $C_1$  is the invariant controller. The damping ratio and undamped natural frequency  $\omega_n$  can specify the system dynamic/steady-state response. Consequently, taking the inversion of  $G$  gives  $C_1 = \frac{G}{1-G} = \frac{1}{s} \frac{\omega_n^2}{s+2\omega_n}$ . Accordingly, the desired states from the invariant controller are determined with  $x_{d1} = \frac{1}{s} \frac{\omega_n^2}{s+2\omega_n}$ ,  $\dot{x}_{d1} = x_{d2} = \frac{\omega_n^2}{s+2\omega_n}$ .

The state space realisation of the invariant controller, which could be used to accommodate future expansion/configuration based on the state space models, has the following expression

$$\begin{aligned} \dot{x}_d &= Ax_d + Be, \quad A = \begin{bmatrix} 0 & 1 \\ 0 & -2\omega_n \end{bmatrix}, \quad B = \begin{bmatrix} 0 \\ 1 \end{bmatrix}, \\ x_{d1} &= Cx_d, \quad C = [\omega_n^2 \quad 0], \quad e = r - y \end{aligned} \quad (4.3)$$

In addition, for the general case of designing the  $n$ th order invariant controller, which requires the  $n$ th order desired state vector while still keeping the second-order performance, it suggests  $G = \frac{C_1}{1+C_1} = \frac{\prod_{i=3}^n p_i}{\prod_{i=3}^n (s+p_i)} \frac{\omega_n^2}{s^2+2\omega_n s+\omega_n^2}$ , which all the extra poles can be assigned with  $\forall p_i \in \prod_{i=3}^n (s+p_i) : p_i \geq (3 \sim 5)\omega_n$ . The invariant controller can be still determined by  $C_1 = \frac{G}{1-G}$ .

## 4.1. Case 1 non-affine nonlinear plant

### 4.1.1. Plant model

$$\begin{aligned} \dot{x}_1 &= x_2 \\ \dot{x}_2 &= -0.6x_2 - x_1x_2 - ux_2 + \sin(u) + 2u + u^3 \\ y &= x_1 + d(t) \end{aligned} \quad (4.3)$$

where the external disturbance  $d(t) = 1$  is added at the outputs.

**UDSM-control:** The design takes two separate tasks: (1) designing the SMI with the inner loop ( $x = K_i(\hat{P}^{-1}, P, x_d)$ ) to achieve  $\hat{I}_{ip} = I_2$  and (2) designing the invariant controller with the external loop to achieve the whole system performance.

- (1) Design of the SMI: Completed at the beginning of the section, which is applicable for both case studies.
- (2) Design of the IC: Specify the whole desired control system performance with the linear second-order transfer function  $G = \frac{\omega_n^2}{s^2+2\omega_n s+\omega_n^2}$ , where

the damping ratio = 0.7 and undamped natural frequency  $\omega_n = 5$ , which is a decayed oscillatory response with zero steady-state error to step reference input. This gives a reference to design the invariant controller  $C_1$  under  $\sum = (\mathcal{F}, C_1)$ . As  $G = \frac{C_1}{1+C_1}$ , taking the inversion gives  $C_1 = \frac{G}{1-G} = \frac{\omega_n^2}{s^2+2\omega_n s} = \frac{125}{s^2+7s}$ . This sets up an external unit feedback loop to achieve the desired system performance and also provides two desired states  $x_{d1} = \frac{25}{s+7} \frac{1}{s}$ ,  $\dot{x}_{d1} = x_{d2} = \frac{25}{s+7}$  for reference for the SMI.

### 4.1.2. Simulations

Figure 5 is a package to show the system output response to a sequence of step references. Figure 6 is a package to show the system output response to a sinusoidal reference  $\sin(0.3t)$ .

## 4.2. Discussions on the simulated plots

This section presents the following understandings from the inspection of the generated plots from the computational experiments on the Simulink platform.

- (1) Dynamic and static targets are well obtained, which are consistent with those analytically designed.
- (2) Control input (Figure 5(b)) is not zero in steady-state; this is because the constant disturbance is added at the system output.
- (3) Robustness should be noted except the known request of plant dynamic order; there is no knowledge in using the plant model structure and parameters in the DI and control system design. Actually, this approach has model-free robust control, which is even more favourably without the need of iterative learning in disturbance estimation and plant model identification.
- (4) Even in the large sliding band boundary thickness  $|\delta| = 0.8$ , the system outputs still have reasonably good accuracy while reducing the possibility of chattering effect. This is because of the set-up of the local SM and the continuous control within the sliding band.
- (5) The control system performance achieved with an external closed loop can improve accuracy and robustness. This configuration is better in these

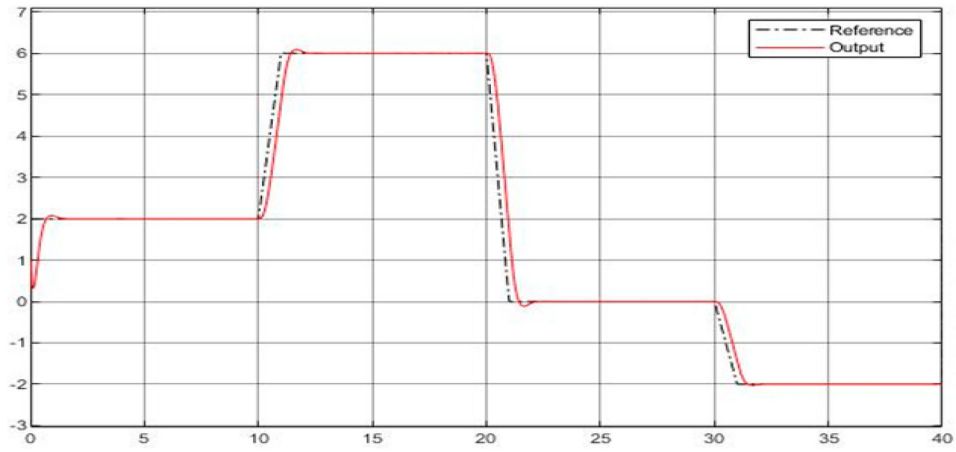


Figure 5a Output response

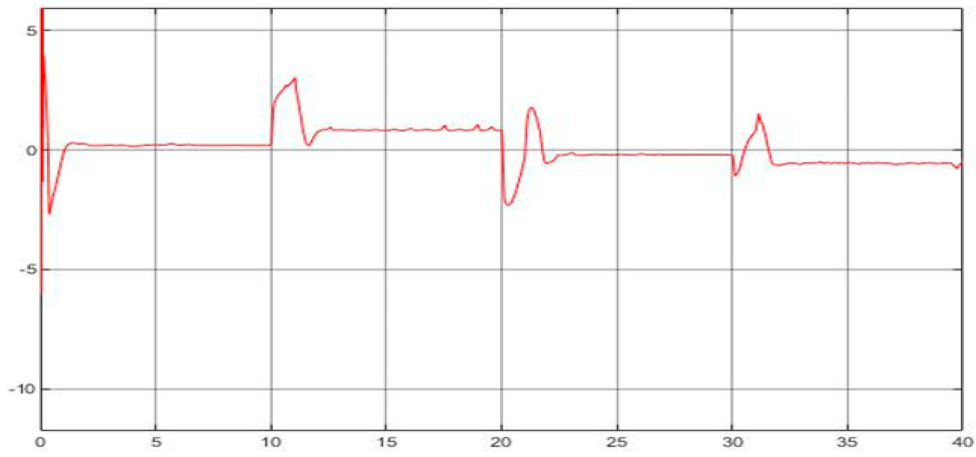


Figure 5b Control input

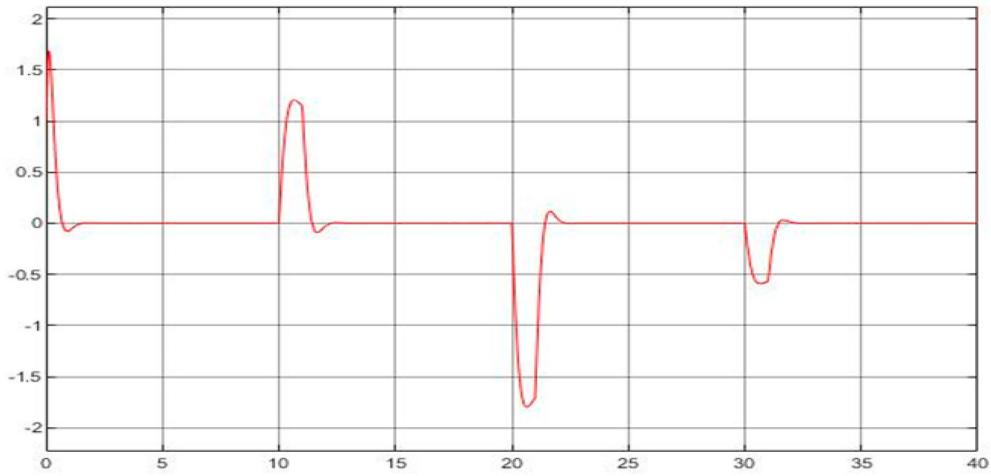


Figure 5c System tracking error

Figure 5. (a) Output response. (b) Control input. (c) System tracking error. Test with step reference inputs.

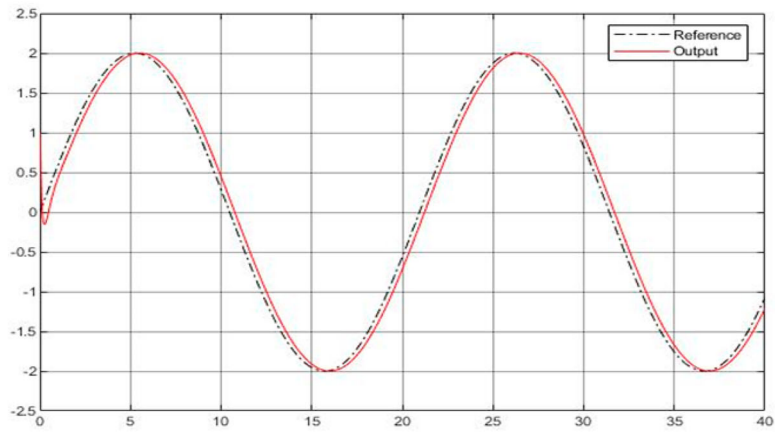


Figure 6a Output response

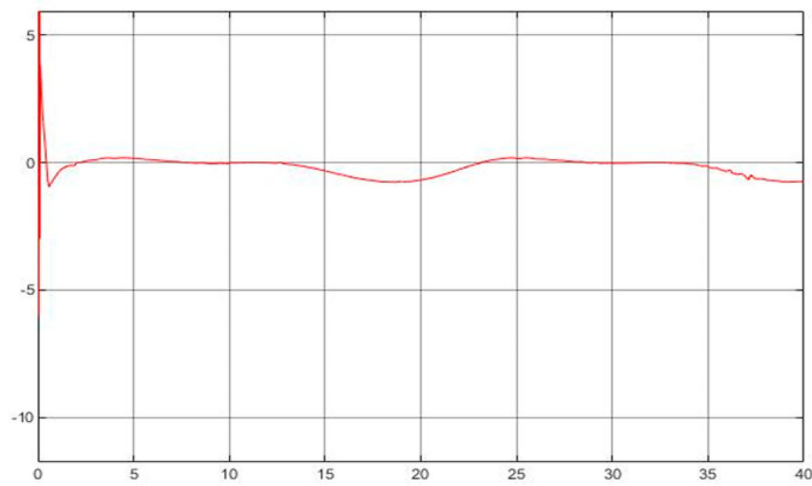


Figure 6b Control input

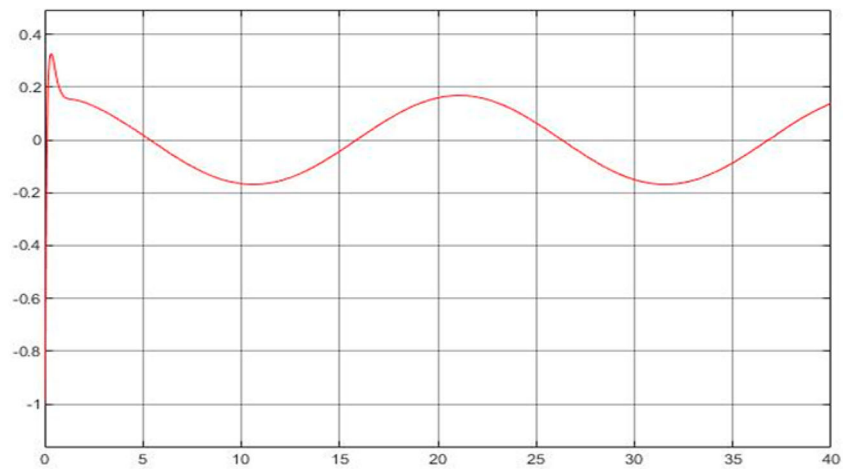


Figure 6c System tracking error

**Figure 6.** (a) Output response. (b) Control input. (c) System tracking error. Test with sinusoidal reference inputs.

aspects than those schemes using reference trajectory generators in open loop (Ren et al., 2015; Yang et al., 2014).

### 4.3. Case 2 rotary servo system having non-affine uncertainties (Ren et al., 2015)

To further demonstrate the characteristics and performance of the proposed DSMC, a rotary servo system, with non-affine uncertainty term added in control input, was selected with computational experiments by Matlab/Simulink, to compare those results obtained using uncertainty and disturbance estimator-based robust control (UDERC) (Ren et al., 2015).

*Plant model:* The following second-order nonlinear dynamic model is referred for this servo system with a non-affine uncertainty added at the control input.

$$\begin{aligned} \begin{bmatrix} \dot{\theta} \\ \dot{\theta} \end{bmatrix} &= \begin{bmatrix} 0 & 1 \\ 0 & -25 \end{bmatrix} \begin{bmatrix} \theta \\ \dot{\theta} \end{bmatrix} + \begin{bmatrix} 0 \\ 80 \end{bmatrix} u \\ &+ \begin{bmatrix} 0 \\ f_2(\theta, \dot{\theta}, u) \end{bmatrix} + \begin{bmatrix} 0 \\ d_2 \end{bmatrix} \end{aligned} \quad (4.4)$$

where the states  $\theta(t)$  and  $\dot{\theta}(t)$  are for the angular position and velocity, respectively;  $u(t)$  for the control input;  $f_2(\theta, \dot{\theta}, u)$  for the non-affine uncertainty added at the control input; and  $d_2(t)$  is the external disturbance. Using common notations in the state space mode-based control system design, let  $x = \begin{bmatrix} \theta \\ \dot{\theta} \end{bmatrix}$ ,  $g(x) = \begin{bmatrix} 0 & 1 \\ 0 & -25 \end{bmatrix} \begin{bmatrix} \theta \\ \dot{\theta} \end{bmatrix}$ ,  $b = \begin{bmatrix} 0 \\ 80 \end{bmatrix}$ ,  $f(x, u) = f_2(\theta, \dot{\theta}, u)$  and  $d = \begin{bmatrix} 0 \\ d_2 \end{bmatrix}$  with  $f_2(\theta, \dot{\theta}, u) = 32(\theta + \dot{\theta} + \arctan(u))$ .

*Control objective:* This is to design the control law  $u$  to drive the system following a desired reference trajectory of

$$\begin{aligned} \begin{bmatrix} \dot{\theta} \\ \dot{\theta} \end{bmatrix} &= \begin{bmatrix} 0 & 1 \\ -900 & -60 \end{bmatrix} \begin{bmatrix} \theta_m \\ \dot{\theta}_m \end{bmatrix} \\ &+ \begin{bmatrix} 0 \\ 900 \end{bmatrix} c \end{aligned} \quad (4.5)$$

where  $\theta_m(t)$  and  $\dot{\theta}_m(t)$  are the reference states, and  $c(t)$  is the command input to stimulate the reference model. In the standard state space equation,  $x_m = \begin{bmatrix} \theta_m \\ \dot{\theta}_m \end{bmatrix}$ ,  $A_m = \begin{bmatrix} 0 & 1 \\ -900 & -60 \end{bmatrix}$  and  $B_m = \begin{bmatrix} 0 \\ 900 \end{bmatrix}$ .

*UDERC:* The control law is formulated with

$$\begin{aligned} u(t) &= b^+ \left[ -g(x) + (A_m x_m(t) + B_m c(t)) \right. \\ &+ \frac{1}{\tau} \left( (I - (A_m + K)\tau)e(t) \right. \\ &\left. \left. - (A_m + K) \int_0^t e(\xi) d\xi \right) \right]. \end{aligned} \quad (4.6)$$

where  $b^+ = (b^T b)^{-1} b^T$  is the pseudoinverse of  $b$ . This simplified control law demonstrates the nature of the UDE-based control strategy. It (1) cancels the known system dynamics to remove the effect to mix up with the other control functions, (2) inserts the desired dynamics assigned by the reference model and (3) adds a proportional-integral-like function to regulate the errors to increase robustness. For the following simulation studies, assign the controller parameters  $K = 0$ ,  $\tau = 0.01$ .

*U<sub>DSM</sub>-control:* The design takes the following tasks: (1) designing the SMI with the inner loop ( $x = K_i(\hat{P}^{-1}, P, x_d)$ ) to achieve  $\hat{I}_{ip} = I_2$  and (2) designing the invariant controller with the external loop to achieve the whole system performance.

- (1) Design of the SMI: Completed at the beginning of the section, which is applicable for both case studies.
- (2) Design of the invariant controller: Choose the same desired closed loop transfer function (Ren et al., 2015)  $G = \frac{\omega_n^2}{s^2 + 2\omega_n s + \omega_n^2}$  with  $\omega_n = \sqrt{90} = 30$  and  $\zeta = 1$ , that is,  $G = \frac{900}{s^2 + 60s + 900}$ . Therefore, the invariant controller  $C_1 = \frac{G}{1-G} = \frac{900}{s^2 + 60s}$ . Accordingly, the two desired states are assigned as  $x_{d1} = \frac{1}{s} \frac{900}{s+60}$ ,  $\dot{x}_{d1} = x_{d2} = \frac{900}{s+60}$ .

*Simulations:* Both UDERC and U<sub>DSM</sub>-control are applied to control the system with an added non-affine uncertainty  $f_2(\theta, \dot{\theta}, u) = 32(\theta + \dot{\theta} + \arctan(u))$  at the control input.

*Test 1:* Tracking a step reference with the external disturbance  $d_2(t) = 0$ . Figure 7 is a pack to show the computational experimental results obtained with the UDERC (Ren et al., 2015) and the U<sub>DSM</sub>-control.

*Test 2:* Tracking a sinusoidal ( $0.5 \cos(0.5\pi t)$ ) reference with the external disturbance  $d_2(t) = 32 \cos(2\pi t)$ . Figure 8 is a pack to show the computational



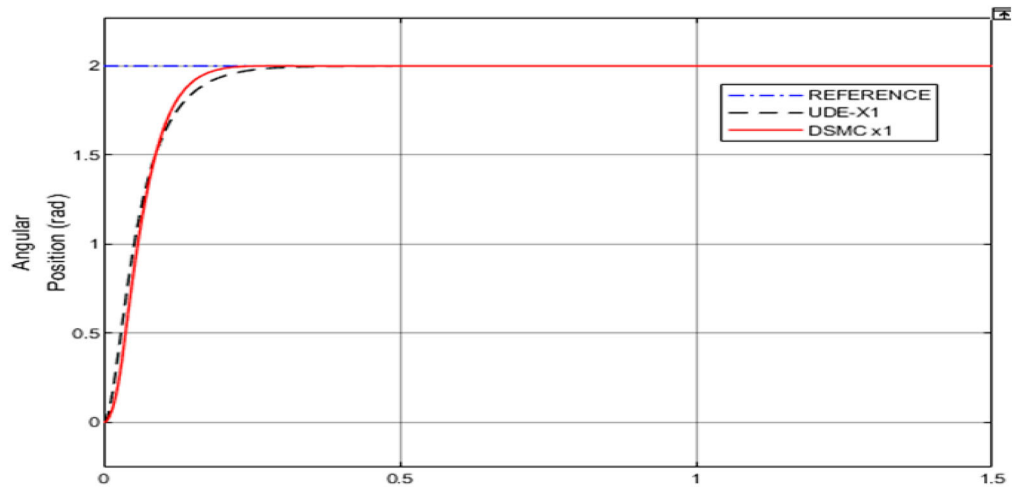
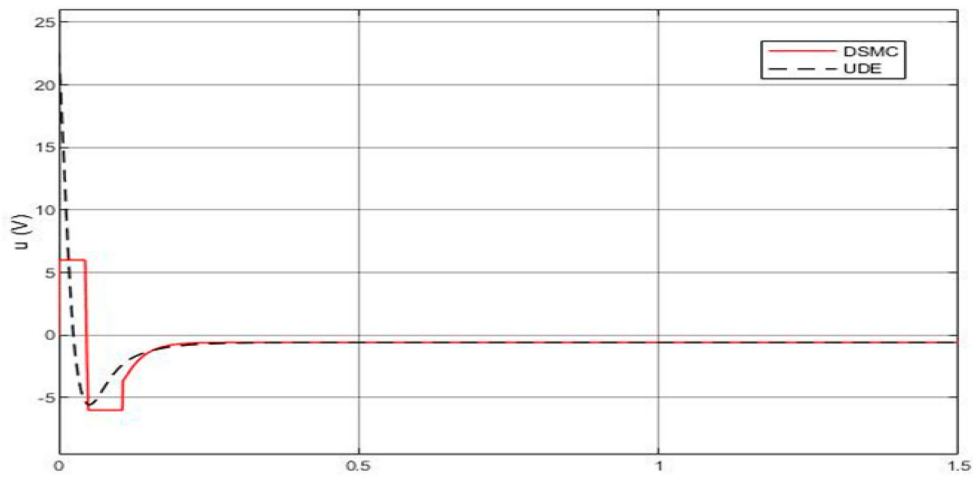
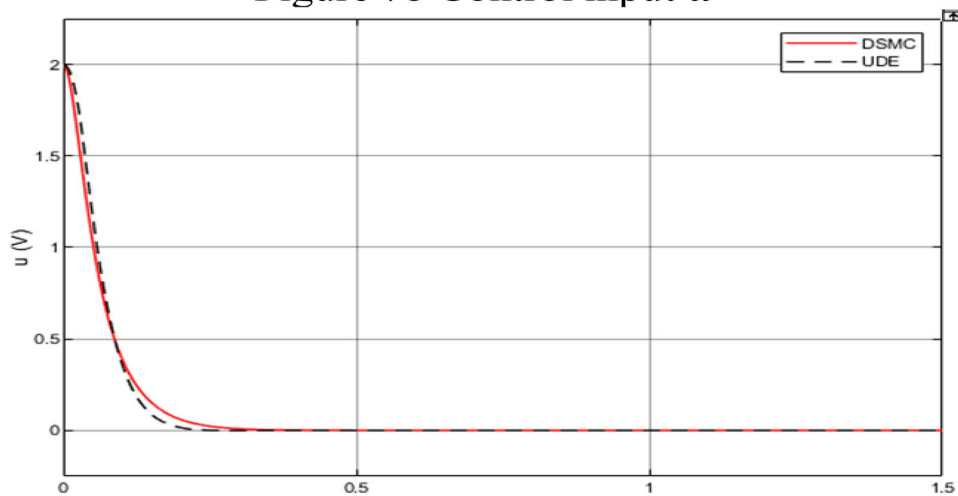
Figure 7a. Output response  $\theta$ Figure 7b Control input  $u$ 

Figure 7c System tracking error

**Figure 7.** (a) Output response  $\theta$ . (b) Control input  $u$ . (c) System tracking error. Test with step reference inputs.

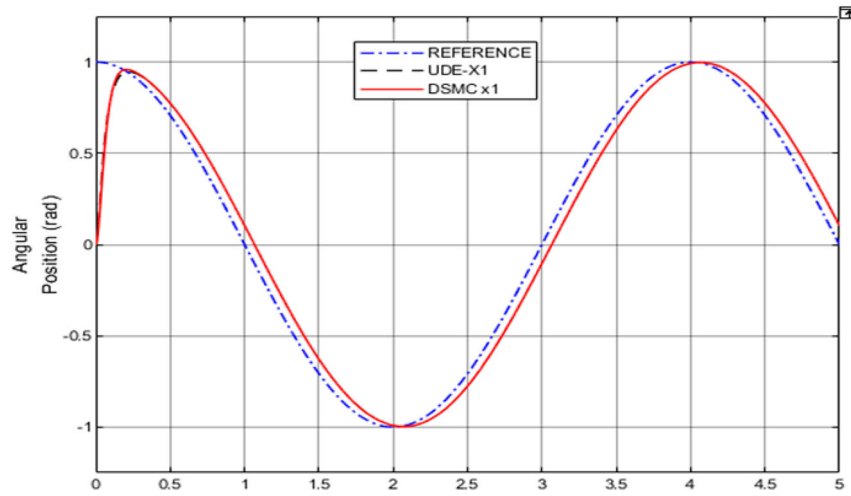


Figure 8a. Output response  $\theta$

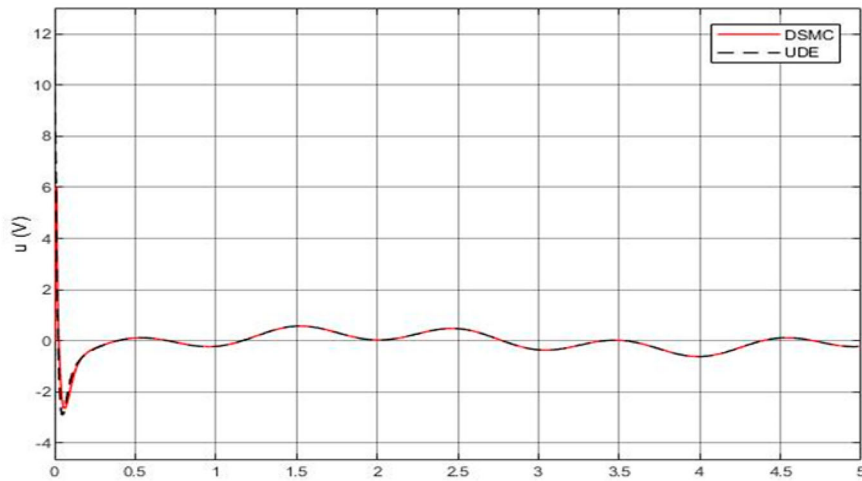


Figure 8b Control input  $u$

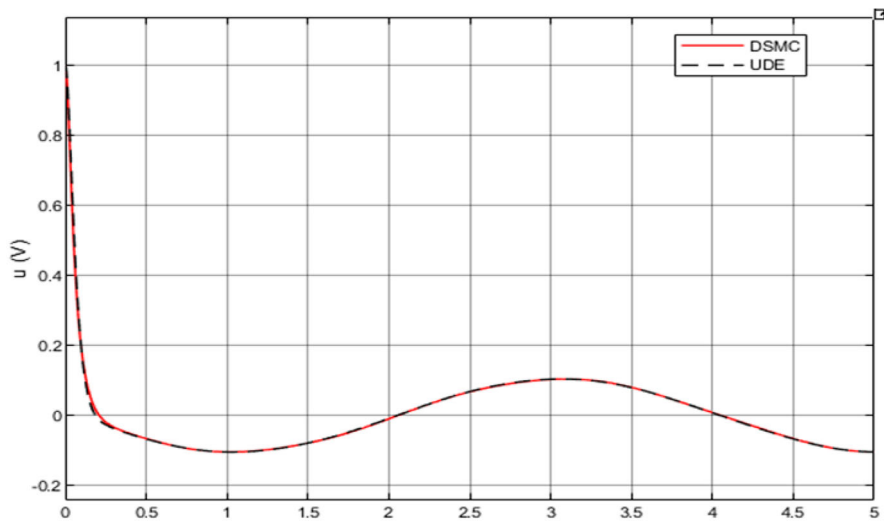


Figure 8. (a) Output response  $\theta$ . (b) Control input  $u$ . (c) System tracking error.

experimental results obtained with the UDERC (Ren et al., 2015) and the  $U_{\text{DSM}}$ -control.

#### 4.4. Comparison on the simulated plots

- (1)  $U_{\text{DSM}}$ -control is confirmed with the repeatability with the same properties as simulated in the first case study.
- (2) Both UDERC and  $U_{\text{DSM}}$ -control can achieve the same specified control objectives.
- (3) UDERC requests three design procedures, plant DI, desired performance implementation and uncertainty estimation/rejection. The  $U_{\text{DSM}}$ -control takes two DIs. Basically, UDERC is a model-based design and  $U_{\text{DSM}}$ -control is a data-driven design without traditional iterative learning routines.
- (4) For dealing with uncertainties and disturbance, the UDERC needs a filter to estimate the uncertainty, but the  $U_{\text{DSM}}$ -control only needs the assumption of the unknown bound.

## 5. Conclusions

The study presents a  $U_{\text{DSM}}$ -control framework, a milestone in robust U-control. The simulation results have demonstrated the conceptual insight and analytical derivations. There are a few bullet points to conclude the study.

*Achieved:* Against classical NDI, this study proposes an expanded robust NDI by cancelling nonlinearities and dynamics and overcomes the plant uncertainty directly in the direct inner loop. The separation of two DIs largely reduces the complexity in the nonlinear control system design. The type of data-driven control does not require iterative learning routines compared with those classical data-driven control approaches. These foundations could be seamlessly integrated with many exiting nonlinear control approaches. Hopefully the DSMC could contribute to the SMC research. In research methods, this study uses basic tools, such as Lyapunov stability, SMC, NDI, to effectively develop innovative solutions for challenging issues in the robust nonlinear control system design.

*Topics for further research:* State observer should be considered sooner or later since full states are not always available in most of the modern control engineering systems. The study results should be expanded

to accommodate some hard control dynamic systems, such as those with large pure time delay, non-minimum phase/unstable nonlinear zero dynamics. If possible, we would like to receive feedback with real control system tests or at least simulations with hardware in loop.

## Acknowledgements

The authors express their gratitude to the editors and the anonymous reviewers for their helpful comments and constructive suggestions with regard to the revision of the paper. The second author is grateful to the partial PhD studentship from the Engineering Modelling and Simulation Research Group of the University of the West of England, UK.

## Disclosure statement

No potential conflict of interest was reported by the author(s).

## Notes on contributors



**Quanmin Zhu** is a professor in control systems at the Department of Engineering Design and Mathematics, University of the West of England, Bristol, UK. He obtained his MSc in Harbin Institute of Technology, China, in 1983 and PhD in Faculty of Engineering, University of Warwick, UK, in 1989. His main

research interests include nonlinear system modelling, identification and control. He has published over 250 papers on these topics, edited various books with Springer, Elsevier and the other publishers, and provided consultancy to various industries. Currently Professor Zhu is an Editor of International Journal of Modelling, Identification and Control, Editor of International Journal of Computer Applications in Technology and Editor of Elsevier book series of Emerging Methodologies and Applications in Modelling, Identification and Control. He is the founder and president of annual International Conference on Modelling, Identification and Control.



**Ruobing Li** received his B.Sc. Degree from Northwestern Polytechnical University in 2018, the M.Sc. Degree from the University of Bristol in 2020. Currently he is pursuing PhD at the Department of Engineering Design and Mathematics, University of the West of England, Bristol, UK. His research focuses on nonlinear system

modelling, simulation, and control.



**Xing-Gang Yan** received his B.Sc. Degree from Shaanxi Normal University, in 1985, M.Sc. Degree from Qufu Normal University in 1991, and a Ph.D. Degree of Engineering from Northeastern University, China, in 1997. Currently, he is Senior Lecturer of Control Engineering at the University of Kent, UK. His research interest includes sliding mode control, decentralised control and fault detection and isolation for interconnected systems and nonlinear time delay systems.

## References

- Chakraborty, A., & Arcak, M. (2009). Time-scale separation redesigns for stabilization and performance recovery of uncertain nonlinear systems. *Automatica*, 45(1), 34–44. <https://doi.org/10.1016/j.automatica.2008.06.004>
- Das, A., Subbarao, K., & Lewis, F. (2009). Dynamic inversion with zero-dynamics stabilisation for quadrotor control. *IET Control Theory & Applications*, 3(3), 303–314. <https://doi.org/10.1049/iet-cta:20080002>
- Du, W., Wu, X., & Zhu, Q. (2012). Direct design of a U-model-based generalized predictive controller for a class of non-linear (polynomial) dynamic plants. *Proceedings of the Institution of Mechanical Engineers, Part I: Journal of Systems and Control Engineering*, 226(1), 27–42. <https://doi.org/10.1177/0959651811409655>
- Geng, X., Zhu, Q., Liu, T., & Na, J. (2019). U-model based predictive control for nonlinear processes with input delay. *Journal of Process Control*, 75, 156–170. <https://doi.org/10.1016/j.jprocont.2018.12.002>
- Horn, J. F. (2019). Non-linear dynamic inversion control design for rotorcraft. *Aerospace*, 6(3), Article 38. <https://doi.org/10.3390/aerospace6030038>
- Hou, Z. S., & Wang, Z. (2013). From model-based control to data-driven control: Survey, classification and perspective. *Information Sciences*, 235, 3–35. <https://doi.org/10.1016/j.ins.2012.07.014>
- Hussain, N. A. A., Ali, S. S. A., Ovinis, M., Arshad, M. R., & Al-Saggaf, U. M. (2020). Underactuated coupled nonlinear adaptive control synthesis using U-model for multivariable unmanned marine robotics. *IEEE Access*, 8, 1851–1865. <https://doi.org/10.1109/ACCESS.2019.2961700>
- Isidori, A. (2013). *Nonlinear control systems*. Springer Science & Business Media.
- Li, R., Zhu, Q., Kiely, J., & Zhang, W. (2020). Algorithms for U-model-based dynamic inversion (UM-dynamic inversion) for continuous time control systems. *Complexity*, 2020. Article ID 3640210. <https://doi.org/10.1155/2020/3640210>
- Lin, Z. (2009, June 17–19). *Low gain and low-and-high gain feedback: A review and some recent results*. 2009 Chinese control and decision conference (pp. lii–lxi). IEEE.
- Miller, C. (2011, August 08–11). *Nonlinear dynamic inversion baseline control law: Architecture and performance predictions*. AIAA guidance, navigation, and control conference, Portland, Oregon (p. 6467).
- Ren, B., Zhong, Q. C., & Chen, J. (2015). Robust control for a class of nonaffine nonlinear systems based on the uncertainty and disturbance estimator. *IEEE Transactions on Industrial Electronics*, 62(9), 5881–5888. <https://doi.org/10.1109/TIE.2015.2421884>
- Shafiq, M., & Haseebuddin, M. (2005). U-model-based internal model control for non-linear dynamic plants. *Proceedings of the Institution of Mechanical Engineers, Part I: Journal of Systems and Control Engineering*, 219(6), 449–458. <https://doi.org/10.1243/095965105X33563>
- Sieberling, S., Chu, Q. P., & Mulder, J. A. (2010). Robust flight control using incremental nonlinear dynamic inversion and angular acceleration prediction. *Journal of Guidance, Control, and Dynamics*, 33(6), 1732–1742. <https://doi.org/10.2514/1.49978>
- Slotine, J. J. E., & Li, W. (1991). *Applied nonlinear control* (Vol. 199, No. 1). Prentice Hall.
- Tarokh, M. (2017). Solving a class of nonlinear inverse problems using a feedback control approach. *Mathematical Problems in Engineering*, 2017, 1–11. <https://doi.org/10.1155/2017/6843614>
- Wang, X., Van Kampen, E. J., Chu, Q., & Lu, P. (2019). Stability analysis for incremental nonlinear dynamic inversion control. *Journal of Guidance, Control, and Dynamics*, 42(5), 1116–1129. <https://doi.org/10.2514/1.G003791>
- Wang, Y. C., Sheu, D., & Lin, C. E. (2015). A unified approach to nonlinear dynamic inversion control with parameter determination by eigenvalue assignment. *Mathematical Problems in Engineering*, 2015. Article ID 548050. <https://doi.org/10.1155/2015/548050>
- Wei, W., Chen, N., Zhang, Z., Liu, Z., & Zuo, M. (2020). U-model-based active disturbance rejection control for the dissolved oxygen in a wastewater treatment process. *Mathematical Problems in Engineering*, 2020. Article ID 3507910. <https://doi.org/10.1155/2020/3507910>
- Yan, X. G., Spurgeon, S. K., & Edwards, C. (2017). *Variable structure control of complex systems*. Communications and control Engineering. Springer.
- Yang, I., Lee, D., & Han, D. S. (2014). Designing a robust nonlinear dynamic inversion controller for spacecraft formation flying. *Mathematical Problems in Engineering*.
- Zhang, W. C., Zhu, Q. M., Mobayen, S., Yan, H., Qiu, J., & Narayan, P. (2020). U-Model and U-control methodology for nonlinear dynamic systems. *Complexity*, 2020. Article ID 1050254. <https://doi.org/10.1155/2020/1050254>
- Zhu, Q. M., & Guo, L. Z. (2002). A pole placement controller for non-linear dynamic plants. *Proceedings of the Institution of Mechanical Engineers, Part I: Journal of Systems and Control Engineering*, 216(6), 467–476. <https://doi.org/10.1177/095965180221600603>
- Zhu, Q. M., Liu, L., Zhang, W. C., & Li, S. Y. (2018). Control of complex nonlinear dynamic rational systems. *Complexity*, 2018. Article ID 8953035. <https://doi.org/10.1155/2018/8953035>
- Zhu, Q. M., Na, J., Boubaker, O., Zhang, W. C., Mahmoud, M. S., & Huang, J. (2020). From complexity to simplicity

- in U-model enhanced control system design. *Mathematical Problems in Engineering*. <https://www.hindawi.com/journals/mpe/si/931240/page/1/>
- Zhu, Q. M., Wang, Y., Zhao, D., Li, S., & Billings, S. A. (2015). Review of rational (total) nonlinear dynamic system modelling, identification, and control. *International Journal of Systems Science*, 46(12), 2122–2133. <https://doi.org/10.1080/00207721.2013.849774>
- Zhu, Q. M., Zhang, W. C., Zhang, J. H., & Sun, B. (2019). U-neural network-enhanced control of nonlinear dynamic systems. *Neurocomputing*, 352, 12–21. <https://doi.org/10.1016/j.neucom.2019.04.008>