



(51) International Patent Classification:

A61M 16/04 (2006.01) A61M 25/10 (2013.01)

(21) International Application Number:

PCT/GB20 18/000044

(22) International Filing Date:

23 March 2018 (23.03.2018)

(25) Filing Language:

English

(26) Publication Language:

English

(30) Priority Data:

1705379.4 04 April 2017 (04.04.2017) GB

(71) Applicants: SMITHS MEDICAL INTERNATIONAL LIMITED [GB/GB]; 1500 Eureka Park, Lower Pemberton, Ashford, Kent TN25 4BF (GB). UNIVERSITY OF KENT of The Registry [GB/GB]; University of Kent, Canterbury, Kent CT2 7NZ (GB).

(72) Inventors: PAGAN, Eric; 18 Stade Street, Hythe, Kent CT21 6BD (GB). FLINT, Jonathan, McNeill; 21 Lammas Park Road, Ealing, London W5 5JD (GB). MCCORD, Chris; Smiths Medical International Limited, 1500 Eureka Park, Lower Pemberton, Ashford, Kent TN25 4BF (GB). GOURLAY, Campbell, W.; University of Kent, Canterbury, Kent CT2 7NZ (GB). BATCHELOR, John; University of Kent, Canterbury, Kent CT2 7NZ (GB). HOLD-

ER, Simon; University of Kent, Canterbury, Kent CT2 7NZ (GB). MAKAROVAITE, Viktorija; University of Kent, Canterbury, Kent CT2 7NZ (GB).

(74) Agent: FLINT, Jonathan, McNeill; 21 Lammas Park Road, Ealing, London W5 5JD (GB).

(81) Designated States (unless otherwise indicated, for every kind of national protection available): AE, AG, AL, AM, AO, AT, AU, AZ, BA, BB, BG, BH, BN, BR, BW, BY, BZ, CA, CH, CL, CN, CO, CR, CU, CZ, DE, DJ, DK, DM, DO, DZ, EC, EE, EG, ES, FI, GB, GD, GE, GH, GM, GT, HN, HR, HU, ID, IL, IN, IR, IS, JO, JP, KE, KG, KH, KN, KP, KR, KW, KZ, LA, LC, LK, LR, LS, LU, LY, MA, MD, ME, MG, MK, MN, MW, MX, MY, MZ, NA, NG, NI, NO, NZ, OM, PA, PE, PG, PH, PL, PT, QA, RO, RS, RU, RW, SA, SC, SD, SE, SG, SK, SL, SM, ST, SV, SY, TH, TJ, TM, TN, TR, TT, TZ, UA, UG, US, UZ, VC, VN, ZA, ZM, ZW.

(84) Designated States (unless otherwise indicated, for every kind of regional protection available): ARIPO (BW, GH, GM, KE, LR, LS, MW, MZ, NA, RW, SD, SL, ST, SZ, TZ, UG, ZM, ZW), Eurasian (AM, AZ, BY, KG, KZ, RU, TJ, TM), European (AL, AT, BE, BG, CH, CY, CZ, DE, DK, EE, ES, FI, FR, GB, GR, HR, HU, IE, IS, IT, LT, LU, LV, MC, MK, MT, NL, NO, PL, PT, RO, RS, SE, SI, SK, SM,

(54) Title: MEDICO-SURGICAL TUBES

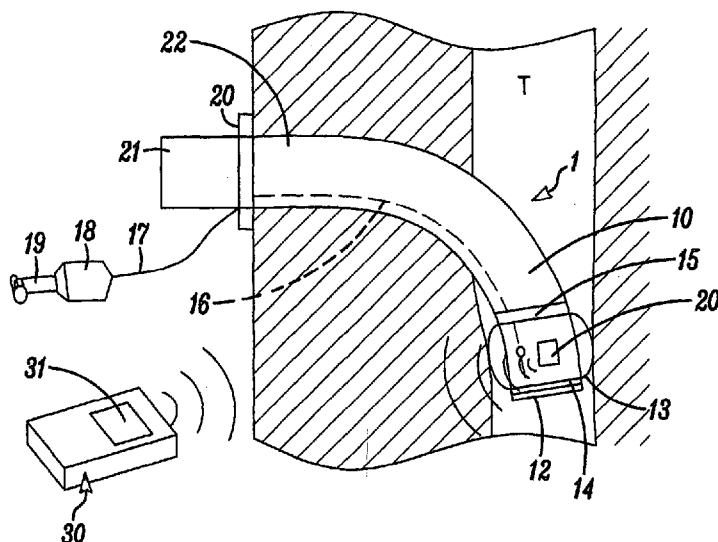

(57) Abstract: A tracheal tube (1) has an inflatable sealing cuff (13, 113) and a pressure sensor (20, 120) in the form of an RFID tag (20, 120) mounted on the shaft (10) of the tube under the cuff to measure pressure within the cuff. Alternatively, the sensor could be mounted on the cuff itself and be responsive to pressure exerted by the cuff against the tracheal wall.



TR), OAPI (BF, BJ, CF, CG, CI, CM, GA, GN, GQ, GW,
KM, ML, MR, NE, SN, TD, TG).

Declarations under Rule 4.17:

- *as to the identity of the inventor (Rule 4.17(i))*
- *as to applicant's entitlement to apply for and be granted a patent (Rule 4.17(H))*
- *of inventorship (Rule 4.17(iv))*

Published:

- *with international search report (Art. 21(3))*

MEDICO-SURGICAL TUBES

This invention relates to medico-surgical tubes of the kind having a shaft and an expansible member on the outside of the shaft adapted to make contact with the surface of a body cavity within which the tube is inserted.

Tracheal tubes are used to supply ventilation and anaesthetic gases to a patient, such as during surgery. The tracheal tube may be inserted via the mouth or nose, in the case of an endotracheal tube, or may be inserted via a surgically-made tracheostomy opening in the neck, in the case of a tracheostomy tube. Most, but not all, tracheal tubes have some form of a seal on their outside which forms a seal between the outside of the tube and the inside of the trachea so that gas flow is confined to the bore of the tube and cannot flow around the outside of the tube, between the tube and the trachea.

The most common form of seal is provided by an inflatable cuff that is inflated and deflated via a small bore lumen extending along the tube and connected towards its rear end to an inflation line terminated by an inflation indicator, valve and connector. These inflatable cuffs may be of the high-volume/low-pressure kind where the cuff is formed of a flexible plastics material moulded with a natural annular or doughnut shape that is inflated without stretching, to contact the wall of the trachea, by relatively low-pressure gas supplied via the inflation line. Alternatively, the cuff may be of the low-volume/high-pressure kind where the cuff is of an elastic material that lies close to the tube shaft when uninflated but is inflated and stretched to a larger diameter by relatively high pressure gas supplied via the inflation line. Various problems exist with both forms of cuff. One problem is the difficulty of preventing secretions that collect above the cuff leaking between the cuff and the wall of the trachea and entering the bronchial passages. The leakage of such secretions is thought to contribute to ventilator-associated pneumonia (VAP).

In order to minimise secretions leaking past the cuff it is important to maintain the optimum contact pressure of the cuff with the tracheal wall, which is typically about 25cmH₂O.

If the cuff pressure is too low then it may allow passages to form along the outside of the cuff through which secretions can flow. It may also prevent effective ventilation by allowing some of the ventilation gas to escape. If cuff pressure is too high it may damage the delicate lining of the trachea. The pressure in the cuff can change during use. The gas by which the cuff is inflated may permeate through the cuff wall over time leading to a gradual loss of pressure.

Alternatively, anaesthetic gas can permeate into the cuff leading to an increase in pressure.

Conventional arrangements for measuring cuff pressure rely on some form of pressure sensor connected to the cuff pressure inflation line outside the body, such as described in US9 180268, US20140261442, US9433737 and WO2012122267. The relatively small bore of these inflation lines means that there is a significant drop in pressure along the line so the pressure monitored is different from the actual pressure within the cuff. There is also the risk that any kink in the inflation line or any external pressure on the inflation indicator balloon connected to the inflation line could affect the pressure reading.

The pressure applied by the outside of the cuff to the tracheal wall can also change if, for example, the tube is displaced or the patient's neck or head is moved.

Sealing members other than inflatable cuffs are used on some tubes, such as of an expansible foam. There are similar problems in other tubes having sealing members. Expansible members are also provided on tubes for purposes other than sealing, such as where pressure needs to be applied to tissue, such as to expand a vessel.

It is an object of the present invention to provide an alternative medico-surgical tube and an arrangement including such a tube.

According to one aspect of the present invention there is provided a medico-surgical tube of the above-specified kind, characterised in that the tube also includes a pressure-responsive device located on the tube and sensitive to pressure of the expansible member, and that the pressure-responsive device is of the kind that provides a radio frequency signal indicative of

pressure of the expansible member when interrogated externally by a separate remote reader device.

The pressure-responsive device may be mounted on or in the expansible member. The expansible member may be a sealing member adapted to seal the tube with the inside of a body cavity. The pressure-responsive device may be mounted on the shaft of the tube under the expansible member, the pressure-responsive device being responsive to pressure within the expansible member. Alternatively, the pressure-responsive device may be located on the exterior of the expansible member and may be responsive to pressure between the exterior of the expansible member and a surface of the body cavity within which the tube is inserted. The expansible member is preferably an inflatable cuff attached to the shaft of the tube by a collar at opposite ends of the cuff. The pressure-responsive device is preferably provided by an RFID tag. The tube is preferably a tracheal tube and the expansible member is preferably a sealing cuff.

According to another aspect of the present invention there is provided an arrangement including a medico-surgical tube according to the above one aspect of the present invention and a reader device operable to interrogate the pressure-responsive device on the tube.

The reader is preferably an RFID reader having a display on which an indication of pressure is displayed.

A tracheostomy tube and an arrangement including a tube and reader according to the present invention will now be described, by way of example, with reference to the accompanying drawings, in which:

Figure 1 is a side elevation view of a tracheostomy arrangement;

Figure 2 is an enlarged side elevation view of the region of the sealing cuff in Figure 1; and

Figure 3 is an enlarged view of the cuff of an alternative tube.

With reference first to Figures 1 and 2, the tracheostomy tube 1 comprises a curved shaft 10 of circular section with a patient end 12 adapted to be located within the trachea T of the patient. The shaft 10 has an expansible member provided by a conventional inflatable sealing cuff 13 towards its patient end 12. The cuff 13 is of a thin, flexible plastics material and is attached with the shaft at opposite ends by respective collars 14 and 15. The cuff 13 may be of the low-pressure/ high-volume kind where the cuff is of a relatively floppy material that can be inflated to seal with the trachea at low pressure, typically around 25cmH₂O. Alternatively, the cuff may be of an elastic material that, in its natural state, lies close to the outside of the shaft. The cuff may be stretched and inflated by supplying a relatively high pressure to the cuff by air or a liquid, such as saline. The cuff 13 is inflated and deflated by means of an inflation lumen 16 extending along the shaft 10 within its wall. Towards its machine end the inflation lumen 16 connects with a small bore inflation line 17 terminated by an inflation indicator balloon 18 and a combined connector and valve 19. A syringe or the like can be connected to the connector 19 to enable air or other inflation fluid to be supplied to or from the cuff 13.

The shaft 10 is moulded or extruded and is bendable but relatively stiff, being made of a plastics material such as PVC or silicone. Alternative shafts could be of a metal such as stainless steel or silver. The machine end 22 of the shaft 10 is adapted, during use, to be located externally and adjacent the tracheostomy opening formed in the patient's neck. The machine end 22 of the shaft 10 has a neck flange 20, by which the tube is secured to the patient's neck, and a coupling 21 to which a mating connector (not shown) can be connected. The mating connector is attached to breathing tubing extending to a ventilator or anaesthetic machine. Alternatively, the coupling 21 may be left open where the patient is breathing spontaneously.

The tube 1 differs from conventional tubes by the inclusion of a pressure-responsive device in the form of a pressure sensor 20 located in or on the cuff 13.

5

As shown in Figure 2, the pressure sensor is provided by a radio frequency identification (RFID) tag 20 of the kind incorporating an element responsive to pressure such as a strain gauge on a deformable substrate. This is a passive device that does not require any internal power supply but instead relies on energisation from an external source in an RFID reader 30 located outside the patient. In the arrangement shown in Figures 1 and 2 the RFID tag 20 is mounted on the outside of the shaft 10, preferably in a shallow recess 21 on the surface of the shaft so that the tag does not project substantially above the outer surface of the shaft. The tag 20 may be attached to the shaft 10 by an adhesive or solvent or by some mechanical means such as by staking. The tag 20 could be encapsulated within the material of the shaft providing the pressure sensing element of the tag was sufficiently exposed, such as by being covered by only a thin, flexible layer of material. The pressure sensing element could be of any conventional kind such as resistive, capacitive or inductive. The tag 20 is located beneath the cuff 13 and between the two collars 14 and 15.

When the RFID tag 20 is energised by the reader 30 it generates a radio frequency signal indicative of the pressure to which it is exposed, that is, the pressure within the cuff 13. This signal is received by the reader 30 and is processed to produce an indication of pressure on a display 31 on the reader. By checking the reader 30 the clinician can confirm that the actual pressure within the cuff is within the optimum desired range. If there is any deviation from this the clinician can simply increase inflation of the cuff or open the valve 19 to allow some of the inflation fluid to escape, as appropriate. The reader 30 could be of the kind that the nurse carries around with him as he checks intubated patients. Alternatively, the reader could be mounted at the bedside and be arranged to monitor the pressure continuously or at regular intervals and to generate an alarm signal if pressure deviates from the desired range. The reader could be incorporated into other equipment, such as, for example a capnograph, ventilation monitor or a general vital signs monitor.

Instead of mounting the sensor on the shaft beneath the cuff it could be mounted on the cuff itself, as shown in Figure 3. This arrangement has an RFID sensor 120 that is flexible and of rectangular shape mounted aligned with the axis of the tube 110 midway along the length of the

cuff 113. The sensor 120 could be of the same kind as described above, which is responsive to pressure, and in this case would respond to the contact pressure between the outside of the cuff 113 and the wall of the trachea. Alternatively, the sensor 120 could provide an indication of pressure indirectly by means of a strain gauge element incorporated into the sensor that responds to flexing of the cuff 113 and sensor as the cuff is inflated and expands. Such a sensor may be more suitable for use on high-pressure cuffs of an elastic material that stretch and expand as they are inflated. Such sensors could be mounted on the outside or inside of the cuff. Where the sealing member is not an inflatable member, but is instead, for example, a foam member that expands to contact the inside of the trachea or other body cavity, the sensor would preferably be mounted on the outside of the member.

The indication of pressure within the cuff need not be provided by a direct pressure measurement but could, for example, be derived indirectly such as by measuring the extent of expansion of the cuff. This could be achieved by use of an RFID tag mounted on the shaft and incorporating a proximity detector responsive to change in the distance between the tag and the cuff wall.

Although there are advantages to the sensor being on or in the sealing cuff it would be possible for it to be mounted at a different location in pressure communication with the cuff, such as outside the patient and in the inflation indicator balloon or connector. Although such an arrangement would not provide a direct indication of pressure in the sealing cuff it would still have the advantage of being of low cost, not requiring any internal power supply and not requiring any cable connection to the sensor.

The RFID sensors 20 and 120 could be prefabricated discrete devices mounted on or inside the cuff. Alternatively, the sensors could be printed on the shaft or the cuff, such as by laser printing with a conductive ink or by laser activation of a printed conductive ink. Alternatively, the sensor could be formed by photo lithographic techniques, or by removing material from a layer to form the desired circuit by chemical etching, laser ablation or the like.

The invention is not confined to tracheal tubes but could, for example, be used in laryngeal tubes, where the preferred inflation pressure range is around 80cmH₂O, or endobronchial tubes with a pressure range of 30-60cmH₂O. The invention could be used on other tubes with sealing cuffs, such as foley catheters. The invention is not confined to tubes adapted to seal with surrounding tissue but could, for example, be used with tubes adapted to apply pressure to surrounding tissue, such as, for example, dilatation catheters for expanding blood vessels.

The present invention enables an indication of pressure exerted by sealing means to be provided at low cost in disposable, single-use tubes and without the need for any internal power. It also avoids the need for cables, which could become tangled with the gas lines and obstruct access to the surgical site. It is believed that only relatively low power is needed in such an arrangement because of the absence of bone between the trachea and the reader, which could otherwise attenuate the radio-frequency signal.

CLAIMS

1. A medico-surgical tube (1) having a shaft (10) and an expansible member (13, 113) on the outside of the shaft adapted to make contact with the surface of a body cavity within which the tube is inserted, characterised in that the tube also includes a pressure-responsive device (20, 120) located on the tube and sensitive to pressure of the expansible member (13, 113), and that the pressure-responsive device (20, 120) is of the kind that provides a radio frequency signal indicative of pressure of the expansible member (13, 113) when interrogated externally by a separate remote reader device (30).
2. A medico-surgical tube according to Claim 1, characterised in that the pressure-responsive device (20, 120) is mounted on or in the expansible member (13, 113).
3. A medico-surgical tube according to any one of the preceding claims, characterised in that the expansible member is a sealing member (13, 113) adapted to seal the tube with the inside of a body cavity.
4. A medico-surgical tube according to any one of the preceding claims, characterised in that the pressure-responsive device (20) is mounted on the shaft (10) of the tube under the expansible member, and that the pressure-responsive device (20) is responsive to pressure within the expansible member (13).
5. A medico-surgical tube according to any one of Claims 1 to 3, characterised in that the pressure-responsive device (120) is located on the exterior of the expansible member (113) and is responsive to pressure between the exterior of the expansible member (113) and a surface of the body cavity within which the tube is inserted.
6. A medico-surgical tube according to any one of the preceding claims, characterised in that the expansible member is an inflatable cuff (13, 113) attached to the shaft (10, 110) of the tube by a collar (14, 15) at opposite ends of the cuff.

7. A medico-surgical tube according to any one of the preceding claims, characterised in that the pressure-responsive device is provided by an RFID tag (20, 120).
8. A medico-surgical tube according to any one of the preceding claims, characterised in that the tube is a tracheal tube (1) and the expansible member is a sealing cuff (13, 113).
9. An arrangement including a medico-surgical tube (1) according to any one of the preceding claims and a reader device (30) operable to interrogate the pressure-responsive device (20, 120) on the tube.
10. An arrangement according to Claim 9, characterised in that the reader is an RFID reader (30) having a display (31) on which an indication of pressure is displayed.

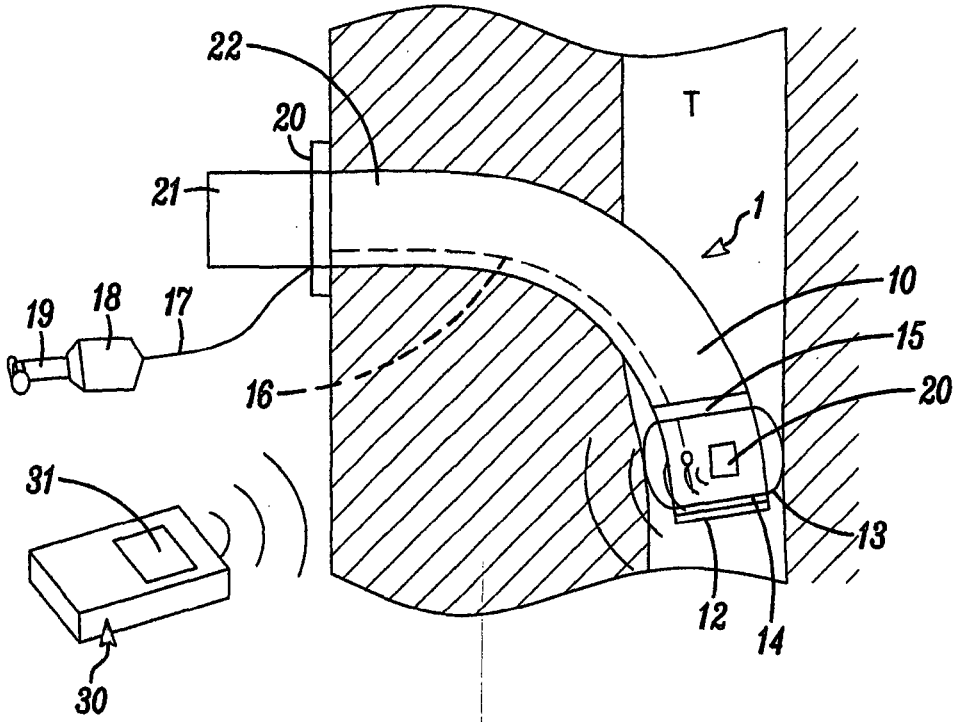

FIG. 1

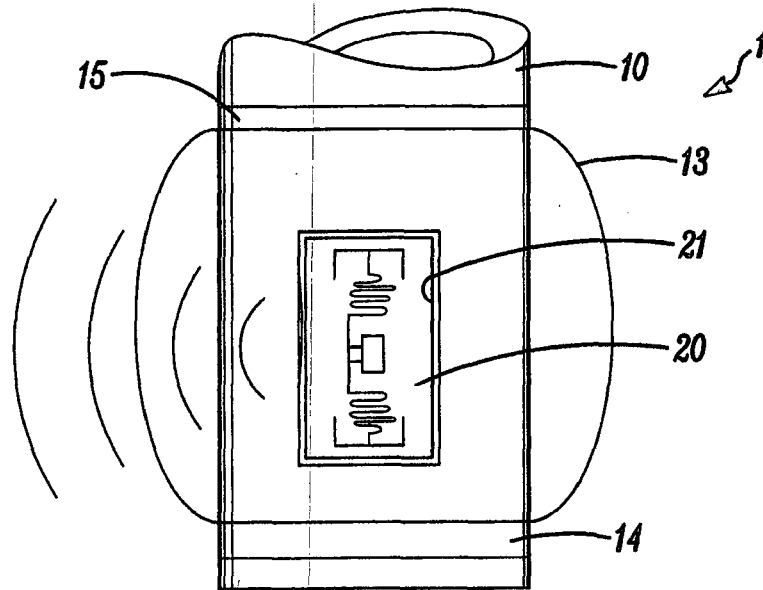

FIG. 2

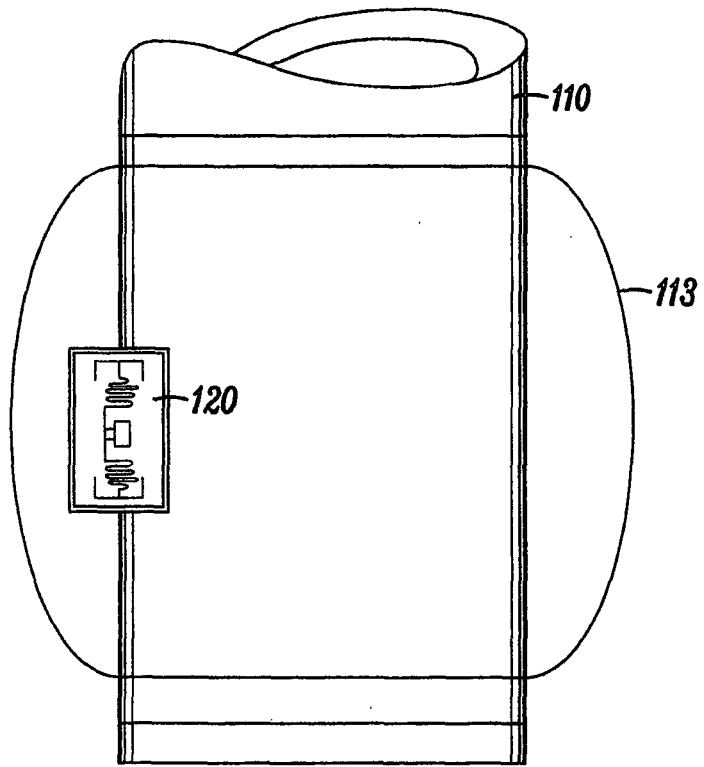

FIG. 3

INTERNATIONAL SEARCH REPORT

International application No
PCT/GB2018/000044

A. CLASSIFICATION OF SUBJECT MATTER
INV. A61M16/04
ADD. A61M25/10

According to International Patent Classification (IPC) or to both national classification and IPC

B. FIELDS SEARCHED

Minimum documentation searched (classification system followed by classification symbols)
A61M

Documentation searched other than minimum documentation to the extent that such documents are included in the fields searched

Electronic data base consulted during the international search (name of data base and, where practicable, search terms used)
EPO-Internal , WPI Data

C. DOCUMENTS CONSIDERED TO BE RELEVANT

Category*	Citation of document, with indication, where appropriate, of the relevant passages	Relevant to claim No.
X	US 8 473 033 B2 (WOOD LOCKETT E [US] ; HAYMAN SARAH [US] ; COVIDI EN LP [US]) 25 June 2013 (2013-06-25)	1-4,6-10
Y	col umn 1, line 7 - line 51 col umn 2, line 26 - col umn 7, line 28 figures 1-6	1-10

X	US 2011/030694 A1 (SCHANER DAVID [US] ET AL) 10 February 2011 (2011-02-10)	1-3 ,5-10
Y	paragraph [0002] - paragraph [0008] paragraph [0021] - paragraph [0046] figures 1-7	1-10

X	US 5 080 107 A (TEVES LEONIDES Y [US]) 14 January 1992 (1992-01-14)	1-4,6-10
Y	col umn 1, line 20 - col umn 3, line 44 col umn 4, line 12 - col umn 8, line 33 figures 1-7	1-10

	-/- .	

Further documents are listed in the continuation of Box C.

See patent family annex.

* Special categories of cited documents :

"A" document defining the general state of the art which is not considered to be of particular relevance

"E" earlier application or patent but published on or after the international filing date

"L" document which may throw doubts on priority claim(s) or which is cited to establish the publication date of another citation or other special reason (as specified)

"O" document referring to an oral disclosure, use, exhibition or other means

"P" document published prior to the international filing date but later than the priority date claimed

"T" later document published after the international filing date or priority date and not in conflict with the application but cited to understand the principle or theory underlying the invention

"X" document of particular relevance; the claimed invention cannot be considered novel or cannot be considered to involve an inventive step when the document is taken alone

"Y" document of particular relevance; the claimed invention cannot be considered to involve an inventive step when the document is combined with one or more other such documents, such combination being obvious to a person skilled in the art

"&" document member of the same patent family

Date of the actual completion of the international search 28 May 2018	Date of mailing of the international search report 07/06/2018
--	--

Name and mailing address of the ISA/ European Patent Office, P.B. 5818 Patentlaan 2 NL - 2280 HV Rijswijk Tel. (+31-70) 340-2040, Fax: (+31-70) 340-3016	Authorized officer Aguado, Mi guel
--	---

INTERNATIONAL SEARCH REPORT

International application No
PCT/GB2018/000044

C(Continuation). DOCUMENTS CONSIDERED TO BE RELEVANT		
Category*	Citation of document, with indication, where appropriate, of the relevant passages	Relevant to claim No.
X	US 2015/066069 AI (DRASLER WILLIAM [US] ET AL) 5 March 2015 (2015-03-05)	1-3 ,6,7 , 9, 10
Y	paragraph [0002] - paragraph [0033] paragraph [0058] - paragraph [0090] figures 1-7	1-10

X	US 2016/157868 AI (TILLMAN BRYAN W [US] ET AL) 9 June 2016 (2016-06-09)	1-3 ,5-7 , 9, 10
Y	paragraph [0002] - paragraph [0015] paragraph [0032] - paragraph [0039] paragraph [0048] - paragraph [0056] figures 1, 2, 6A-8	1-10

X	US 2013/281885 AI (ROWBOTTOM JAMES R [US] ET AL) 24 October 2013 (2013-10-24)	1-3 ,5-10
Y	paragraph [0002] - paragraph [0011] paragraph [0023] - paragraph [0039] paragraph [0043] - paragraph [0047] figures 1-3 , 6	1-3 ,5-10

Y	WO 2016/083782 AI (NOTTINGHAM UNIVERSITY HOSPITALS NHS TRUST [GB]; UNIV NOTTINGHAM [GB]) 2 June 2016 (2016-06-02) page 1, line 3 - page 8, line 24 page 10, line 4 - page 19, line 13 figures 1-3b, 6, 9-11	1-3 ,5-10

Y	US 2010/242957 AI (FORTUNA ANIBAL DE OLIVEIRA [BR]) 30 September 2010 (2010-09-30) paragraph [0002] - paragraph [0040] paragraph [0059] - paragraph [0097] figures 1-15	1-4,6,7 , 9, 10

Y	WO 2015/150721 AI (SMITHS MEDICAL INT LTD [GB]) 8 October 2015 (2015-10-08) page 1, line 3 - page 3, line 28 page 4, line 18 - page 7, line 24 figures 1-5	6-10

INTERNATIONAL SEARCH REPORT

Information on patent family members

International application No PCT/GB2018/000044
--

Patent document cited in search report	Publication date	Patent family member(s)	Publication date
US 8473033	B2	25-06-2013	US 2010319702 AI 23-12-2010
			US 2013269703 AI 17-10-2013
			Wo 2010147902 AI 23-12-2010

US 2011030694	AI	10-02 -2011	US 2011030694 AI 10-02-2011
			wo 2011017528 AI 10-02-2011

US 5080107	A	14-01 -1992	NONE

US 2015066069	AI	05-03 -2015	CA 2739326 AI 15-04-2010
			JP 2012505050 A 01-03-2012
			JP 2014073406 A 24-04-2014
			US 2010094209 AI 15-04-2010
			US 2011218564 AI 08-09-2011
			US 2015066069 AI 05-03-2015
			wo 2010042869 AI 15-04-2010

US 2016157868	AI	09-06 -2016	US 2016157868 AI 09-06-2016
			wo 2015006607 AI 15-01-2015

US 2013281885	AI	24-10 -2013	EP 2651284 A2 23-10-2013
			US 2013281885 AI 24-10-2013
			wo 2012082715 A2 21-06-2012

Wo 2016083782	AI	02-06 -2016	EP 3223893 AI 04-10-2017
			US 2017340216 AI 30-11-2017
			wo 2016083782 AI 02-06-2016

US 2010242957	AI	30-09 -2010	US 7762261 BI 27-07-2010
			US 2010242957 AI 30-09-2010

wo 2015150721	AI	08-10-2015	NONE
