



Kent Academic Repository

Stoeber, Joachim (2000) *Worry, thoughts, and images: A new conceptualization*. In: von Hecker, Ulrich and Dutke, Stephan and Sedek, Grzegorz, eds. *Generative Mental Processes and Cognitive Resources*. Kluwer, London/ Dordrecht, pp. 223-244. ISBN 0-7923-6562-3.

Downloaded from

<https://kar.kent.ac.uk/23279/> The University of Kent's Academic Repository KAR

The version of record is available from

This document version

UNSPECIFIED

DOI for this version

Licence for this version

UNSPECIFIED

Additional information

Versions of research works

Versions of Record

If this version is the version of record, it is the same as the published version available on the publisher's web site. Cite as the published version.

Author Accepted Manuscripts

If this document is identified as the Author Accepted Manuscript it is the version after peer review but before type setting, copy editing or publisher branding. Cite as Surname, Initial. (Year) 'Title of article'. To be published in *Title of Journal*, Volume and issue numbers [peer-reviewed accepted version]. Available at: DOI or URL (Accessed: date).

Enquiries

If you have questions about this document contact ResearchSupport@kent.ac.uk. Please include the URL of the record in KAR. If you believe that your, or a third party's rights have been compromised through this document please see our [Take Down policy](https://www.kent.ac.uk/guides/kar-the-kent-academic-repository#policies) (available from <https://www.kent.ac.uk/guides/kar-the-kent-academic-repository#policies>).

Stöber, J. (2000). Worry, thoughts, and images: A new conceptualization. In U. von Hecker, S. Dutke, & G. Sedek (Eds.), *Generative mental processes and cognitive resources* (pp. 223-244). London: Kluwer.

Worry, Thoughts, and Images: A New Conceptualization

Joachim Stöber

University of Greifswald

Abstract

The present chapter addresses the relations between worry, thoughts, and images. It is organized into three parts. Part 1 outlines T. D. Borkovec's avoidance theory of worry, namely that worry reduces aversive imagery. Part 2 considers two mechanisms by which worry may reduce imagery, namely limitation of processing resources and verbal abstraction. Moreover, as there is little evidence for the first, but some evidence for the latter, Part 2 presents a new conceptual model of the relations between worry, thoughts, and images. Part 3 presents a brief outline beyond anxiety research on how avoidance theory and the verbal abstraction hypothesis may relate to the phenomenon of ruminative coping with depression.

Keywords

Anxiety; Imagery; Working memory; Abstraction; Depression; Rumination

Worry, Thoughts, and Images: A New Conceptualization

Introduction

Worry clearly is a pervasive and important phenomenon. Everyone worries every once in a while. For most individuals, worry is an experience they have at least every other day (Tallis, Davey, & Capuzzo, 1994). As a fluctuating momentary state, worry represents an important marker of negative mood (Schimmack, 1997). As a stable habitual response, it shows close associations with major dimensions of personality such as trait anxiety (Stöber, 1995) and neuroticism (Keogh, French, & Reidy, 1998). Meta-analyses have shown that worry is the component of anxiety that is mainly responsible for the detrimental effects of anxiety on performance both in academics and in sports (Kleine, 1990; Seipp, 1991). In the medical domain, it is the symptom most commonly reported by patients with psychological problems who consult their physicians (Goldberg, Bridges, Duncan-Jones, & Grayson, 1987). In psychopathology, chronic excessive worry is the cardinal criterion for a diagnosis of generalized anxiety disorder (GAD) as put forward by the third, revised edition of the Diagnostic and Statistical Manual of Mental Disorders, the DSM-III-R (American Psychiatric Association, 1987). Moreover, worry shows close associations with depression. This goes for all levels of depression including depressive mood states, trait-like depressive affect as well as clinical depression (V. Andrews & Borkovec, 1988; Molina, Borkovec, Peasley, & Person, 1998; Starcevic, 1995; Stöber & Joormann, in press).

The present chapter deals with the relationship of worry, thoughts, and images. It is organized in five parts. First, I will introduce the avoidance theory of worry. Second, I will review the evidence concerning a central hypothesis of avoidance theory, namely that worry reduces aversive imagery. Thirdly, I will take a critical look at the possibility that

limitations of processing resources are responsible for imagery reduction in worry. Because the available evidence is not supportive of this claim, the fourth part of the present chapter will present a new, alternative conceptualization of the relationship between worry, thoughts, and images, namely the verbal abstraction hypothesis. Fifth, I will take a short look beyond anxiety research by presenting a brief outline on how avoidance theory and verbal abstraction hypothesis may relate to the phenomenon of ruminative coping with depression.

The Avoidance Theory of Worry

Systematic research on worry started with the seminal work by Liebert and Morris (1967) on worry in test anxiety. For the following two decades, worry research remained restricted to the domain of test anxiety and performance. With the inclusion of worry in the DSM-III-R, however, theory and research on worry and associated processes gained new momentum (cf. Davey & Tallis, 1994). This included not only pathological worry as experienced in GAD but also normal, nonpathological worry and everyday worries (e.g., Borkovec, Shadick, & Hopkins, 1991; Stöber, 1995; Tallis et al., 1994; Tallis, Eysenck, & Mathews, 1992). Despite the considerable amount of information that has been acquired on both normal and pathological worry, one question still draws considerable debate. This is the question of the functions of worry (Borkovec, 1994; Davey, 1994; Freeston, Rhéaume, Letarte, Dugas, & Ladouceur, 1994; Mathews, 1990; Stöber, 1996b, 1998b). Paraphrasing Freeston et al. (1994), the question is why do people worry and why do they continue to worry even though worry is clearly an aversive experience associated with pessimism, problem exaggeration, performance disruption, and emotional discomfort?

As to this question, the most intriguing and comprehensive answer up to date is presented by the avoidance theory of worry (Borkovec, 1994; Borkovec et al., 1991;

Borkovec & Lyonfields, 1993). It holds that worry is a conceptual mental activity that involves a predominance of verbal thought as compared to imagery. Verbal thought about aversive material elicits only little cardiovascular response in comparison to imagery of the same material (Vrana, Cuthbert, & Lang, 1986). The reason is that the abstract conceptual system, including the verbal system, is less closely tied to efferent command into affective, physiological, and behavioral systems. (Compare, for example, reading about a horrible accident with looking at a full-color picture of the accident scene.) Consequently, people spontaneously use verbalization as a strategy for abstraction, disengagement, and emotional control when confronted with arousing imagery, for example, when viewing slides of aversive material such as disfigured bodies or starving children (Tucker & Newman, 1981). In the same way, worrisome self-talk may be used as a cognitive avoidance response to suppress aversive fear imagery, thus avoiding associated somatic responses and emotional processing of fear-related material.¹

Whereas the first account of avoidance theory spoke of worry was associated with suppression of imagery (Borkovec et al., 1991; Borkovec & Lyonfield, 1993; East & Watts, 1994), later accounts of the theory refrained from using the term "imagery suppression" and instead talked about worry being avoidance of imagery or worry being helpful in avoiding imagery (Borkovec, 1994; Borkovec et al., in press). The central hypotheses of avoidance theory, however, remained the same: Following Eysenck (1992, p. 111), the avoidance theory of worry contains three central hypotheses. The first is that worry involves mainly verbal thoughts. The second is that worry reduces imagery activity. The third is that worry reduces somatic physiological activity. In the following, I will concentrate on the second hypothesis of the avoidance theory, namely the imagery reduction hypothesis. Because this hypothesis is closely related to the first hypothesis, I

will start with a review of the empirical evidence that has been produced in support of the hypothesis that worry involves mainly verbal thoughts.

What is the empirical evidence for this notion? First empirical evidence for the hypothesis that worry consists predominantly of verbal thoughts stems from two studies reported by Borkovec and Lyonfields (1993). In both studies, a large nonclinical sample of student participants was asked about the formal qualities of their worrying. In the first study, participants received a series of questionnaires that also contained the question: "When you do worry, does it involve mostly thoughts, mostly images, or both?" (p. 102). With these three answer categories, 51% of the participants reported that their worrying consisted of mostly thoughts, 46% that it was both, and only 3% that it was mostly imagery. In the second study, participants were asked if their worry was mostly thoughts or mostly images. With this answer format, 70% of the participants reported that their worry was mostly thoughts and 30% that it was mostly images. Further and more detailed evidence for the relative dominance of thoughts over images in worry came from the study by Tallis et al. (1994). Again, a large student sample was requested to indicate the composition of their worrying with respect to the two components, thoughts and images. This time, however, participants were provided with a nine-point answer scale ranging from "Thoughts only" to "Images only". With the sample mean corresponding to the category "Mostly thoughts and some images" on the scale, 71% of the participants reported a predominance of thoughts rather than images. 15% reported that worry was thoughts only. In contrast, no participant reported images only. Overall, the findings of the three studies suggest that, when worrying, thoughts are notably predominant over imagery.

However, retrospective summary reports about the relative frequency of thoughts versus imagery in worry may give a distorted picture. Moreover, they do not convey any information regarding the second hypothesis that worry actually reduces imagery. Both of these restrictions were addressed in two experimental studies that employed manipulation of worry and on-line assessment of worry content. In a study by Borkovec and Inz (1990), a sample of GAD clients and a nonclinical control group were subjected to a period of self-relaxation and a period of worrying. During both phases, participants were repeatedly prompted at random intervals to report whether their present mentation was predominantly an image, a thought, or both (also allowing for "unsure" answers). When prompted during the relaxation phase, controls reported 57% images (versus 15% thoughts) whereas GAD clients reported 36% images (versus 33% thoughts). When prompted during the worry phase, both groups showed reduced imagery compared to the relaxation phase with controls reporting 26% images (versus 44% thoughts) and GAD patients reporting 21% images (versus 39% thoughts). This suppression effect of worry on imagery was replicated by East and Watts (1994) with a student sample of high-worriers. Corroborating the previous findings, their participants reported 33% images (versus 30% thoughts) during relaxation, but only 13% images (versus 39% thoughts) after worry had been induced.

The two experimental studies show that, also in concurrent reports on the formal qualities of worrisome mentation, worry consists predominantly of verbal thought. Moreover and more importantly, they demonstrate that worry is associated with a reduction of imagery. Yet, critics may claim that relaxation is an unsuitable control condition for worry because the difference between worry and relaxation may be attributed to relaxation enhancing imagery, not to worrying decreasing imagery. Even

though Hull and Render (1984) found that a single session of relaxation did not affect imagery, it may be important to note that the imagery-suppression effect of worry is not restricted to the comparison with relaxation. Zuellig and Borkovec (1996), for example, found similar differences in a comparison of worry and trauma recall. During trauma recall, imagery was predominant (53% images versus 38% verbal thoughts). During worrying, verbal thought was again predominant (21% images versus 64% verbal thoughts). Thus, also when compared to trauma recall, worry is associated with reduced imagery.

Worry and the Reduction of Imagery: In Search of an Explanatory Mechanism

As described above, the hypothesis that worry is associated with reduced imagery has received substantial empirical support. On the theoretical level, however, there remain some open questions (cf. East & Watts, 1994; Eysenck, 1992; Stöber, 1996b). One important question concerns the link between worrisome thought and reduced imagery. This question is of paramount importance to the avoidance theory of worry because it is closely related to the explanation of emotional suppression in worry. In the following, I will discuss two mechanisms by which worry may reduce imagery, namely (a) that worry reduces imagery by means of suppression resources used for imagery processing and (b) that worry reduces imagery by means of abstraction of verbal thought. In this, I will demonstrate that there is no empirical support for the first position, but some support for the latter. Moreover, (c) I will present a conceptual model of how imagery reduction by verbal abstraction may look like.

Worry and Reduced Imagery: Limitation of Processing Resources

As a potential explanatory mechanism for reduced imagery in worry, Borkovec (1994) suggested that the limitation of processing resources may lead to imagery

suppression in worry. More specifically, he stated that "if one is excessively focused on conceptual activity of any type, fewer attentional resources are available for other external or internal information" (p. 22). Equating the term "excessive focus on conceptual activity" with worry and the term "other internal information" with imagery, this would arrive at a theoretical model in which worry suppresses imagery by occupying resources needed for imagery processing.

Research on anxiety and performance has repeatedly demonstrated that worry is associated with performance decrements on capacity demanding tasks (Mueller, 1992). It is commonly held that the reason for these decrements lies in the working memory system (e.g., Eysenck, 1979). The argument is that worrisome thoughts occupy processing resources, thus limiting the available resources for task processing. However, I doubt that this model is able to explain the effect of worry reducing imagery. The reason is that verbal thought and imagery do not seem to occupy the same resources in working memory.

As was demonstrated by Baddeley (1986), working memory is not a unitary system. Rather, working memory seems to consist of three subsystems: a central executive and two slave systems. The first slave system is the articulatory loop, later renamed the phonological loop. This system acts as a short-term buffer for phonemic material such as verbal thought. The second slave system is the visuo-spatial scratch pad, later renamed the visuo-spatial sketch pad (VSSP). This system acts as a short-term buffer for visual imagery (Baddeley, 1990). The central executive is a supervisory system responsible for coordinating the flow of information between the two slave systems and long-term memory. If worry suppresses imagery by occupying resources needed for imagery processing, worry should either limit resources of the VSSP or limit resources of

the central executive in a way that the coordination of information exchange between central executive and VSSP is distorted.

The available research, however, does not speak in favor of this hypothesis. Markham and Darke (1991) examined the effects of test anxiety on verbal and spatial task performance. They presented a group of high-anxious and a group of low-anxious participants a number of verbal and visuo-spatial tasks, namely (a) a digit span task, designed to utilize only the phonological loop; (b) a spatial span task, designed to utilize only the VSSP; (c) a verbal reasoning task, designed to utilize both central executive and phonological loop; and (d) a spatial reasoning task, designed to utilize both central executive and VSSP. Task performance was analyzed with respect to response times and number of correct responses. In both parameters, high-anxious participants showed detrimental task performance compared to low-anxious participants only in the verbal reasoning task. In the two visuo-spatial tasks, high-anxious participants showed the same performance as low-anxious participants. Anxiety was measured using the Test Anxiety Scale (Sarason, 1984). This scale contains mostly items that capture the worry component of test anxiety. Thus, it is a reasonable assumption that the high-anxious participants had increased levels of worry during task-performance, particularly as all tasks were administered under ego-threat conditions. Therefore the findings suggest that worry interferes with verbal thought processing, but not with imagery processing.

Corresponding findings were reported by Rapee (1993). In a conversion of the usual perspective to investigate the detrimental effects of worry on task performance, Rapee investigated the detrimental effects of various tasks on worry performance. These tasks were (a) an articulatory suppression task, designed to utilize only the phonological loop; (b) a figurative key-striking task, designed to utilize only the VSSP; (c) a random

letter-generation task, designed to utilize both the phonological loop and the central executive; and (d) a random key-striking task, designed to utilize both the VSSP and the central executive. Participants were randomly assigned to one of the four tasks. For each participant, there was a worry-alone condition and a worry-plus-task condition. In the worry-alone condition, participants were instructed to worry about a current concern. In the worry-plus-task condition, participants were instructed to continue worrying about the current concern while simultaneously working on the assigned task. In both conditions, participants were prompted for their thoughts. Afterwards, these thoughts were rated for worry content. Results indicated that only the task that utilized both phonological loop and central executive was associated with a significant decrement in the proportion of worrisome thought. Whereas there was a nonsignificant trend also for the phonological suppression task to decrease the amount of worry, neither of the two visuo-spatial tasks had any effect on worrying.

In sum, the pattern of findings from both studies (Markham & Darke, 1991; Rapee, 1993) does not provide any support for the hypothesis that worry occupies resources for imagery processing. Thus, limitation of capacity is unlikely to account for imagery reduction in worry.

Worry and Reduced Imagery: Abstract verbalization

Moreover, it is questionable if the dual-tasking framework adequately captures the relationship between thoughts and images in worry. According to Borkovec's frequently cited definition of worry, "worry is a chain of thoughts and images, negatively affect-laden and relatively uncontrollable. The worry process represents an attempt to engage in mental problem solving on an issue whose outcome is uncertain but contains the possibility of one or more negative outcomes" (Borkovec, Robinson, Pruzinsky, &

DePree, 1983, p. 10). According to this definition, thoughts and images in worrying are were not unrelated nor competing processes, but simply different sides of the same coin.

With this change in perspective, a more appropriate theoretical framework for looking at thought and imagery in worrying may be dual coding theory (Paivio, 1971, 1986).

According to this theory, verbal thought is always associated with imagery.

Consequently, also worrisome thought is always associated with imagery. At first sight, this theoretical framework seems to present more questions than answers. How can worry suppress imagery when worry is predominantly thought and when thought is always associated with imagery? However, the solution may be quite simple. The reason is that abstract words and sentences are associated with imagery that is slower compared to imagery associated with concrete words and sentences. Moreover, imagery associated with abstract verbalizations is less vivid. Thus, if worry were associated with verbal abstraction, this may account for the experience of reduced imagery in worry.

First evidence for an association between worry and verbal abstraction was found in a series of studies on worry and problem elaboration (Stöber, 1996b). The idea of linking worry with problem elaboration goes back to theoretical considerations by Schönflug (1984, 1989). According to Schönflug (1984; Stöber, 1996a), all problem situations can be defined by three classes of variables: (a) focal problems, (b) antecedent problems (or risks), and (c) consequential problems (or negative consequences). In line with this assumption, the analysis of a problem includes not only the analysis of focal aspects, but also the analysis of potential antecedents and potential negative consequences. Because elaborating on potential problems and constructing negative models of the future is a central element of the worry process (Tallis & Eysenck, 1994), the concept of problem elaboration readily lends itself to the analysis of worrying: With a

current concern presented as the focal problem, worrisome problem elaboration can be assessed by having participants generate potential antecedents and potential negative consequences for this focal problem (cf. Stöber, 1996b, 1998b).

In line with this conception, a first series of studies was conducted in which participants elaborated on problems that were associated with different degrees worry (Stöber, 1996b). These problems were taken from the items of the Worry Domains Questionnaire (WDQ) (Tallis et al., 1992). The WDQ presents a set of 25 everyday worries such as making mistakes at work, feeling insecure around others, or running out of money. For each item, participants indicate their degree of worry on a scale ranging from "Not at all" to "Extremely". Besides providing a reliable and valid measure of habitual worry (Stöber, 1998a), the WDQ can be used to select single items with different degrees of associated worry for worry elaboration (e.g., East & Watts, 1994). This was done in series of studies by Stöber (1996b, Studies 2-4). In these studies, participants were presented with WDQ items for which they had indicated different degrees of worry. Each item was presented as a focal problem in a problem elaboration chart, and participants were asked to generate as many potential antecedents for this problem and as many consequences of this problem as they could think of. After the experiments, two independent raters rated the participants' generations for concreteness. For this, a five-point scale from Abstract (1) to Concrete (5) was used. The scale's endpoints were further explicated by the labels "indistinct, cross-situational, equivocal, unclear, aggregated " for Abstract and "distinct, situationally specific, unequivocal, clear, singular" for Concrete. Across studies, the results showed that the more participants worried about a given item, the less concrete were their problem elaborations of this item. Drawing on research that

shows intimate links between concreteness and imagery, this finding was interpreted as supportive evidence for reduced imagery in worry.

However, these studies by (Stöber, 1996b) had some serious limitations. First, all problem elaborations were rated only for concreteness, not for imagery. Even with intimate links between concreteness and imagery, the empirical evidence would have been stronger if parallel findings for imagery were obtained. Second, the finding was obtained in a post-hoc fashion. Only after aggregating across the three studies, a convincing inverse relationship between worry and concreteness emerged. This rendered the validity and replicability of the finding questionable. Third, all three studies used the same method to assess worrisome thought, namely problem elaboration. Consequently, the finding may have been method-specific and thus of limited generality.

To replicate and extend the findings of my first studies, I and some students of mine conducted two further studies (Stöber, Tepperwien, & Staak, 1998). In these studies, three changes were introduced to overcome the limitations described above. First, participants' generations were rated separately for concreteness and imagery. Second, the degree of worry was systematically varied within participants: Each participant selected two no-worry items, two low-worry items, and two high-worry items from his or her WDQ answers. Third, the two studies used different methods to assess participants' elaborations. In Study 1, we employed again problem elaboration charts to capture the content of worrisome elaborations. For each of the six selected WDQ items, participants were asked to generate three potential antecedents and three potential negative consequences. In Study 2, we employed catastrophizing interviews (Vasey & Borkovec, 1992) to capture worrisome elaborations. For each of the six selected WDQ items, participants were asked to "catastrophize" on the potential negative consequences. The

procedure for the catastrophizing interviews followed the modifications introduced by Davey, Jubb, and Cameron (1996). Participants were repeatedly asked what worried them most about X. In the first step, X was the selected WDQ item; in the second step, X was the answer given in the first step; in the third step, X was the answer given in the second step; etc. This process was repeated until the participants repeated themselves or decided to stop. In both studies, participants' generations were rated for concreteness and for imagery separately. For concreteness, the five-point rating scale from my previous studies (Stöber, 1996b) was used again. For the imagery ratings scale, we constructed a new scale. Borrowing from previous work (Baschek, Bredenkamp, Oehrle, & Wippich, 1977), imagery was rated on a five-point scale ranging from Evokes a mental image not at all or only very reluctantly and slowly (1) to Evokes a mental image very easily and fast (5).

Figure 1 presents the results.

In both studies, there was a highly significant effect of worry on the quality of the associated problem elaborations. As in the previous studies (Stöber, 1996b), the problem elaborations associated with higher degrees of worry showed less concreteness. The same effect was found for imagery. Moreover, both effects showed a significant linear trend: The more participants worried about a given problem, the lower was the degree of concreteness and imagery of associated thoughts. Finally, all effects in the problem elaborations charts could be replicated with the catastrophizing interviews. This indicated that the findings are generalizable across different methods to assess worrisome thoughts. In sum, the findings on worry, problem elaboration, and catastrophizing confirmed that worrying was associated with verbal productions of reduced concreteness that evoked less imagery.

Worry, Thoughts, and Imagery: A New Conceptualization

In sum, the findings on worry, concreteness, and imagery in problem elaboration and catastrophizing (Stöber, 1996b; Stöber et al., 1998) provide strong additional support for the avoidance theory of worry. Moreover, they may contain explanatory potential to answer the question how worrying may reduce aversive imagery. In this, concreteness is the key variable. The reason is that research conducted in the framework of dual coding theory (Paivio, 1971, 1986) has demonstrated that the concreteness of words and sentences exerts a major influence on speed, ease, and vividness of associated imagery. Already in one of his first studies, Paivio (1966) found that participants took three seconds to generate an elaborate mental image for concrete words whereas they took four to five seconds to generate an elaborate mental image for abstract words. Moreover, the concreteness of words has been shown to explain over 60% of the variance in the ease with which these words evoke imagery (Marschark & Cornoldi, 1991), even after statistical control of other imagery-related variables such as the meaning, meaningfulness, emotionality, and pleasantness of words (Campos, 1992, 1995). Finally, it has been demonstrated that sentences of high concreteness evoke images of again high concreteness and high vividness (Paivio, 1991). Consequently, when worrisome thought is of reduced concreteness, worry-related imagery will be both relatively slow and relatively "unvivid" (i.e., weak, dull; cf. Ahsen, 1985). This may explain why imagery is reduced once people start to worry.

A schematic illustration of the proposed relationship between worry, thoughts, and images is given in Figure 1. In this, the stream of worrisome mentation is conceptualized as a chain of thoughts and a chain of images, running in parallel. The top half of Figure 1 illustrates the relationships of concreteness-abstractness in thought with vividness-unvividness and speed in imagery. The first relationship illustrated is that concrete

thoughts evoke vivid images and that abstract thoughts evoke unvivid images. In the chain of thoughts, filled squares symbolize concrete thoughts and empty squares symbolize abstract thoughts. In the chain of images, filled circles symbolize vivid images and empty circles symbolize unvivid images. The second relationship illustrated is that concrete thoughts evoke images faster than abstract thoughts. This is symbolized by a greater delay in the association between thoughts and images when thoughts are abstract: In the chain of thoughts, concrete thoughts have a more direct reference to a mental image whereas abstract thoughts have a more delayed reference to their associated images.² Following this, worrying can be conceptualized as illustrated in the bottom half of Figure 1. With reference to the findings on worry and concreteness (Stöber, 1996b; Stöber et al., 1998), worrisome thought is hypothesized to be a chain of thoughts that are mostly abstract compared to the chain of thoughts associated with normal, worry-free thought. As a consequence, worry is associated with a chain of images that are mostly unvivid. Moreover, due to the greater delay between abstract thoughts and associated images, the worry-related chain of images may contain more overlaps and more gaps. With this, imagery in states of worrying may subjectively appear discontinuous or "thinned out". Accordingly, the subjective reports on the quality of worrying attest that thoughts are predominant over images.

The advantages of this new conceptualization of the relationship between worry, thoughts, and images are threefold. First and foremost, it makes the empirically unsupported notion of worry suppressing imagery (Borkovec et al., 1991; Borkovec & Lyonfields, 1993; East & Watts, 1994) obsolete. Instead, worry is presumed to be associated with comparatively slow and unvivid imagery. To reduce imagery, worriers simply have to avoid a verbal concretization of their fears, for example, by expressing

their fears in vague terms or as questions—a typical behavior of pathological worriers according to Butler (1994). Two examples may clarify this point. As a first example, consider some parent who is worrying about his or her teenage daughter not coming home late at night. Keeping the worrisome thoughts abstract (e.g., "What if something bad happened?") would be associated to less vivid imagery than concrete thoughts of the "something bad" that may have happened (e.g., "What if she got raped?"). Thus, verbal abstraction of the potential catastrophe may help to escape aversive imagery and avoid associated fear responses or panic. As a second example, consider the use of euphemisms in everyday language. Also here, verbal abstraction is a means to avoid aversive imagery and emotional arousal when speaking about highly aversive events. This is demonstrated by common euphemistic formulations in the face of death and dying. The beloved grandmother "passed away" (instead of "died"), and the young soldier "fell" on the battlefield (instead of "was killed"). Compared to the more concrete term (to die, to be killed), the verbal abstraction produced by the euphemism is bound to elicit imagery that is less vivid and, consequently, less aversive and less emotionally distressing.

Second, the new conceptualization takes better account of the data concerning the relatively large percentage of "both"-answers in the retrospective summary reports looking at the formal qualities of worrying. In the study by Tallis et al. (1994), for example, only a small percentage of participants reported that their worry consisted of "thoughts only". For most participants, worry was both thoughts and images, even though the latter to a lesser degree. Also in the two experimental studies that employed a worry manipulation and a thought-sampling procedure (Borkovec & Inz, 1990; East & Watts, 1994), there was a large percentage of "both"-answers in the worry periods, with percentages ranging from 28% to 37%. Third, the new conceptualization of worry,

thoughts, and imagery is more compatible with recent reformulations and extensions of the avoidance theory of worry (Borkovec, 1994; Borkovec et al., in press) that have dropped the concept of imagery suppression. Instead, worry is now conceptualized as an avoidance response that helps to escape aversive imagery. In this, the new conceptualization presented here may show how.

Worry and Imagery Avoidance: A Possible Explanation for Ruminative Coping with Depression?

If worry is associated with verbal abstraction and unvivid imagery, worrying may not only help to escape aversive imagery and emotional distress related to potential future catastrophes. It may also help to escape imagery and distress related to past loss and trauma. As mentioned in the introductory paragraph, worry shows close association with depression in both normal emotional experience and psychopathology. Moreover, two recent studies (Frankel, Fresco, Mennin, Turk, & Heimberg, 1998; Hoyer, Rebstock, & Stangier, 1998) demonstrated that worry shows close associations with ruminative coping with depression. However, both studies failed to find the predicted specificities for worry and rumination with respect to anxiety and depression. Worrying was not specific for anxiety, and rumination not specific for depression. Instead, both studies found that worrying and ruminative coping correlated equally strongly with measures of anxiety and depression. Accordingly, some authors (e.g., Schwarzer, 1996) have questioned that one should make a distinction between worry and rumination at all.

If one accepts that worry and rumination either are the same or at least very similar, the abstraction hypothesis of worry may also shed new light on the phenomenon of ruminative coping with depression (Nolen-Hoeksema, Parker, & Larson, 1994).

Ruminative coping is defined as a specific type of emotion-focused coping, characterized

by a chronic, passive focus on one's own negative emotions. In an impressive series of studies, Nolen-Hoeksema and collaborators demonstrated that ruminative coping is a common means of dealing with depressive mood following traumatic events such as bereavement (Nolen-Hoeksema et al., 1994; Nolen-Hoeksema, McBride, & Larson, 1997) or natural disaster (Nolen-Hoeksema & Morrow, 1991). In this, worry plays a major role as becomes evident from the following quote.

People engaged in ruminative coping worry excessively but passively about their depression. Some examples of ruminative responses to depressed mood include isolating oneself and thinking about one's symptoms (e.g., sitting at home thinking "I just don't feel like doing anything"), worrying about the implications of one's depression (e.g., "What does it mean that I feel this way?"), and worrying about the consequences of one's distress (e.g., "What if I don't get over this?"). (Nolen-Hoeksema et al., 1994, p. 92)

From the studies on ruminative coping with depression, however, it has remained unclear why people retreat to worry and rumination after traumatic losses. Nolen-Hoeksema (1991) argued that parents may contribute to the development of a ruminative coping style by displaying rumination when in a sad or depressed. By copying the parental coping styles, children adopt rumination as a habitual response. However, this does not explain why the parents chose to ruminate in the face of depressive mood. The avoidance theory of worry may fill this theoretical gap. As was demonstrated by Zuellig and Borkovec (1996), worrying about a current concern was associated with a significantly smaller percentage of imagery compared to trauma recall. In the same way that worry helps to avoid aversive fear imagery and associated emotional processing in

states of anxiety, rumination may help to avoid intrusive trauma imagery and associated emotional processing in depression.

The obvious parallels of worry and ruminative coping in depression may point to potential future directions in theory and research on worry. The last 15 years have seen great efforts to find critical features that distinguish anxiety from depression. One prominent example is the cognitive content-specificity hypothesis of anxiety and depression (Beck, Brown, Steer, Eidelson, & Riskind, 1987; Beck & Clark, 1988). A central aspect of this hypothesis is that anxious thought centers around the themes of threat and danger whereas depressive thought centers around the themes of loss and failure. Despite these important advantages, researchers should not lose sight of common features and similarities (e.g., G. Andrews, 1996). Worry and rumination seem to be such common features. Moreover, whereas specific contents may distinguish anxious and depressive thought, it may well be that a more global dimension like concreteness-
abstraction of thought may prove critical for understanding anxiety maintenance as well as depression maintenance. Thus, in future research both on anxiety and on depression, concreteness and imagery may warrant closer attention.

References

- Ahsen, A. (1985). Unvividness paradox. Journal of Mental Imagery, *9*, 1-18.
- American Psychiatric Association (Ed.). (1987). Diagnostic and statistical manual of mental disorders: Third edition-revised (DSM-III-R). Washington, DC: Author.
- Andrews, G. (1996). Comorbidity in neurotic disorders: The similarities are more important than the differences. In R. M. Rapee (Ed.), Current controversies in the anxiety disorders (pp. 3-20). New York: Guilford.
- Andrews, V. H., & Borkovec, T. D. (1988). The differential effects of inductions of worry, somatic anxiety, and depression on emotional experience. Journal of Behavior Therapy and Experimental Psychiatry, *19*, 21-26.
- Baddeley, A. (1986). Working memory. Oxford, England: Oxford University Press.
- Baddeley, A. (1990). Human memory: Theory and practice. Boston, MA: Allyn and Bacon.
- Baschek, I.-L., Bredenkamp, J., Oehrle, B., & Wippich, W. (1977). Bestimmung der Bildhaftigkeit (I), Konkretheit (C) und der Bedeutungshaltigkeit (m') von 800 Substantiven [Determination of imagery (I), concreteness (C), and meaningfulness (m') of 800 nouns]. Zeitschrift für experimentelle und angewandte Psychologie, *14*, 353-396.
- Beck, A. T., Brown, G., Steer, R. A., Eidelson, J. I., & Riskind, J. H. (1987). Differentiating anxiety and depression: A test of the cognitive content-specificity hypothesis. Journal of Abnormal Psychology, *96*, 179-183.
- Beck, A. T., & Clark, D. A. (1988). Anxiety and depression: An information processing perspective. Anxiety Research, *1*, 23-36.
- Borkovec, T. D. (1994). The nature, functions, and origins of worry. In G. C. L. Davey & F. Tallis (Eds.), Worrying: Perspectives on theory, assessment, and treatment (pp. 5-33). New York: Wiley.
- Borkovec, T. D., & Inz, J. (1990). The nature of worry in generalized anxiety disorder: A predominance of thought activity. Behaviour Research and Therapy, *28*, 153-158.
- Borkovec, T. D., & Lyonfields, J. D. (1993). Worry: Thought suppression of emotional processing. In H. W. Krohne (Ed.), Attention and avoidance: Strategies in coping with aversiveness (pp. 101-118). Seattle, WA: Hogrefe and Huber.
- Borkovec, T. D., Ray, W. J., & Stöber, J. (in press). Worry: A cognitive phenomenon intimately linked to affective, physiological, and interpersonal behavioral processes. Cognitive Therapy and Research.
- Borkovec, T. D., Robinson, E., Pruzinsky, T., & DePree, J. A. (1983). Preliminary exploration of worry: Some characteristics and processes. Behaviour Research and Therapy, *21*, 9-16.
- Borkovec, T. D., Shadick, R. N., & Hopkins, M. (1991). The nature of normal and pathological worry. In R. Rapee & D. H. Barlow (Eds.), Chronic anxiety: Generalized anxiety disorder and mixed anxiety-depression (pp. 29-51). New York: Guilford.
- Butler, G. (1994). Treatment of worry in generalised anxiety disorder. In G. C. L. Davey & F. Tallis (Eds.), Worrying: Perspectives on theory, assessment, and treatment (pp. 209-228). New York: Wiley.
- Campos, A. (1992). Concreteness, emotionality, and meaningfulness as determiners of the imagery values of words when meaning is controlled. Bulletin of the Psychonomic Society, *30*, 367-368.
- Campos, A. (1995). Imagery, concreteness, emotionality, meaningfulness, and pleasantness of words. Perceptual and Motor Skills, *80*, 867-880.

- Davey, G. C. L. (1994). Pathological worrying as exacerbated problem-solving. In G. C. L. Davey & F. Tallis (Eds.), Worrying: Perspectives on theory, assessment, and treatment (pp. 35-59). New York: Wiley.
- Davey, G. C. L., Jubb, M., & Cameron, C. (1996). Catastrophic worrying as a function of changes in problem-solving confidence. Cognitive Therapy and Research, *20*, 333-344.
- Davey, G. C. L., & Tallis, F. (Eds.). (1994). Worrying: Perspectives on theory, assessment, and treatment. New York: Wiley.
- East, M. P., & Watts, F. N. (1994). Worry and the suppression of imagery. Behaviour Research and Therapy, *32*, 851-855.
- Eysenck, M. W. (1979). Anxiety, learning, and memory: A reconceptualization. Journal of Research in Personality, *13*, 363-385.
- Eysenck, M. W. (1992). Anxiety: The cognitive perspective. Hillsdale, NJ: Lawrence Erlbaum Associates.
- Frankel, A. N., Fresco, D. M., Mennin, D. S., Turk, C. L., & Heimberg, R. G. (1998, November). Distinct and overlapping features of rumination and worry: The relationship of cognitive production to negative affective states. Poster presented at the meeting of the Association for Advancement of Behavior Therapy, Washington, DC.
- Freeston, M. H., Rhéaume, J., Letarte, H., Dugas, M., & Ladouceur, R. (1994). Why do people worry? Personality and Individual Differences, *17*, 791-802.
- Goldberg, D. P., Bridges, K., Duncan-Jones, P., & Grayson, D. (1987). Dimensions of neuroses seen in primary-care settings. Psychological Medicine, *17*, 461-470.
- Hoyer, J., Rebstock, U., & Stangier, U. (1998, May). Ist Grübeln spezifisch für Depression und Sich-Sorgen spezifisch für Angst? [Is rumination specific for depression and worrying specific for anxiety?]. Poster presented at the meeting of the Fachgruppe Klinische Psychologie der Deutschen Gesellschaft für Psychologie, Hamburg, Germany.
- Hull, C. R., & Render, G. F. (1984). The effect of relaxation, fantasy journeys and free imagery on control and vividness of imagery. Journal of Mental Imagery, *8*, 67-78.
- Kleine, D. (1990). Anxiety and sport-performance: A meta-analysis. Anxiety Research, *2*, 113-131.
- Keogh, E., French, C. C., & Reidy, J. (1998). Predictors of worry. Anxiety, Stress, and Coping, *11*, 67-80.
- Liebert, R. M., & Morris, L. W. (1967). Cognitive and emotional components of test anxiety: A distinction and some initial data. Psychological Reports, *20*, 975-978.
- Markham, R., & Darke, S. (1991). The effects of anxiety on verbal and spatial task performance. Australian Journal of Psychology, *43*, 107-111.
- Marschark, M., & Cornoldi, C. (1991). Imagery and verbal memory. In C. Cornoldi & M. A. McDaniel (Eds.), Imagery and cognition (pp. 133-182). New York: Springer.
- Mathews, A. (1990). Why worry? The cognitive function of anxiety. Behaviour Research and Therapy, *28*, 455-468.
- Molina, S., Borkovec, T. D., Peasley, C., & Person, D. (1998). Content analysis of worrisome streams of consciousness in anxious and dysphoric participants. Cognitive Therapy and Research, *22*, 109-123.
- Mueller, J. H. (1992). Anxiety and performance. In A. P. Smith & D. M. Jones (Eds.), Handbook of human performance (Vol. 3, pp. 127-160). London: Academic Press.
- Nolen-Hoeksema, S. (1991). Responses to depression and their effects on the duration of depressive episodes. Journal of Abnormal Psychology, *100*, 569-582.
- Nolen-Hoeksema, S., McBride, A., & Larson, J. (1997). Rumination and psychological distress among bereaved parents. Journal of Personality and Social Psychology, *72*, 855-862.

- Nolen-Hoeksema, S., & Morrow, J. (1991). A prospective study of depression and posttraumatic stress symptoms after a natural disaster: The 1989 Loma Prieta earthquake. Journal of Personality and Social Psychology, *61*, 115-121.
- Nolen-Hoeksema, S., Parker, L. E., & Larson, J. (1994). Ruminative coping with depressed mood following loss. Journal of Personality and Social Psychology, *67*, 92-104.
- Paivio, A. (1966). Latency of verbal associations and imagery to noun stimuli as a function of abstractness and generality. Canadian Journal of Psychology, *20*, 378-387.
- Paivio, A. (1971). Imagery and verbal processes. New York: Holt, Rhinehart, and Winston.
- Paivio, A. (1986). Mental representations: A dual coding approach. New York: Oxford University Press.
- Paivio, A., with Marschark, M. (1991). Integrative processing of concrete and abstract sentences. In A. Paivio (Ed.), Images in the mind: The evolution of a theory (pp. 134-154). New York: Harvester Wheatsheaf.
- Rapee, R. M. (1993). The utilization of working memory by worry. Behaviour Research and Therapy, *31*, 617-620.
- Sarason, I. G. (1984). Stress, anxiety, and cognitive interference: Reactions to tests. Journal of Personality and Social Psychology, *46*, 929-938.
- Schimmack, U. (1997). Das Berliner-Alltagssprachliche-Stimmungs-Inventar (BASTI): Ein Vorschlag zur kontentvaliden Erfassung von Stimmungen [The Berlin Everyday Language Mood Inventory (BELMI): Toward the content valid assessment of moods]. Diagnostica, *43*, 150-173.
- Schönplflug, W. (1984). Regulation und Fehlregulation im Verhalten: X. Entlastung und Belastung durch gesundheitsfördernde Maßnahmen [Adaptive and maladaptive regulation of behavior: X. Relief and burden associated with supportive health measures]. Psychologische Beiträge, *26*, 692-721.
- Schönplflug, W. (1989). Anxiety, worry, prospective orientation, and prevention. In C. D. Spielberger & I. G. Sarason (Eds.), Stress and anxiety (Vol. 12, pp. 245-258). Washington, DC: Hemisphere.
- Schwarzer, R. (1996). Thought control of action: Interfering self-doubts. In I. G. Sarason, G. R. Pierce, & B. R. Sarason (Eds.), Cognitive interference: Theories, methods, and findings (pp. 99-115). Mahwah, NJ: Lawrence Erlbaum Associates.
- Seipp, B. (1991). Anxiety and academic performance: A meta-analysis of findings. Anxiety Research, *4*, 27-41.
- Starcevic, V. (1995). Pathological worry and major depression: A preliminary report. Behaviour Research and Therapy, *33*, 55-56.
- Stöber, J. (1995). Besorgnis: Ein Vergleich dreier Inventare zur Erfassung allgemeiner Sorgen [Worrying: A comparison of three inventories for measuring general worries]. Zeitschrift für Differentielle und Diagnostische Psychologie, *16*, 50-63.
- Stöber, J. (1996a). Anxiety and the regulation of complex problem situations: Playing it safe? In W. Battmann & S. Dutke (Eds.), Processes of the molar regulation of behavior (pp. 105-118). Scottsdale, AZ: Pabst.
- Stöber, J. (1996b). Besorgnis und Besorgtheit: Untersuchungen über Problemräume, deren Strukturierung und Elaboration [Worrying and Worriers: Studies on problem spaces, their structuring and elaboration]. Frankfurt/M., Germany: Lang.
- Stöber, J. (1998a). Reliability and validity of two widely-used worry questionnaires: Self-report and self-peer convergence. Personality and Individual Differences, *24*, 887-890.
- Stöber, J. (1998b). Worry, problem solving, and suppression of imagery: The role of concreteness. Behaviour Research and Therapy, *36*, 751-756.

- Stöber, J., & Joormann, J. (in press). Worry, procrastination, and perfectionism: Differentiating amount of worry, pathological worry, anxiety, and depression. Cognitive Therapy and Research.
- Stöber, J., Tepperwien, S., & Staak, M. (1998). Worry, concreteness, and imagery in problem elaboration and catastrophizing. Unpublished manuscript.
- Tallis, F., Davey, G. C. L., & Capuzzo, N. (1994). The phenomenology of non-pathological worry: A preliminary investigation. In G. C. L. Davey & F. Tallis (Eds.), Worrying: Perspectives on theory, assessment, and treatment (pp. 61-89). New York: Wiley.
- Tallis, F., & Eysenck, M. W. (1994). Worry: Mechanisms and modulating influences. Behavioural and Cognitive Psychotherapy, 22, 37-56.
- Tallis, F., Eysenck, M. W., & Mathews, A. (1992). A questionnaire for the measurement of nonpathological worry. Personality and Individual Differences, 13, 161-168.
- Tucker, D. M., & Newman, J. P. (1981). Verbal versus imaginal cognitive strategies in the inhibition of emotional arousal. Cognitive Therapy and Research, 5, 197-202.
- Vasey, M. W., & Borkovec, T. D. (1992). A catastrophizing assessment of worrisome thoughts. Cognitive Therapy and Research, 16, 505-520.
- Vrana, S. R., Cuthbert, B. N., & Lang, P. J. (1986). Fear imagery and text processing. Psychophysiology, 23, 247-253.
- Zuellig, A. R., & Borkovec, T. D. (1996, November). Predominance of thoughts and images during trauma recall and worry. Poster presented at the meeting of the Association for Advancement of Behavior Therapy, New York, NY.

Acknowledgments

Preparation of this paper was supported in part by German Research Foundation (DFG) grant STO 350/1-1. I would like to thank the conference participants for their valuable input following the discussion of my presentation. Moreover, I would like to thank Alexandra Freund and the editors for helpful comments and suggestions on earlier versions of this chapter.

Address all correspondence to Joachim Stöber, University of Greifswald, Department of Psychology, Franz-Mehring-Str. 47, D-17487 Greifswald, Germany.
Email: jstoeber@rz.uni-greifswald.de.

Footnotes

¹For a recent comprehensive review of the avoidance theory of worry and the associated empirical evidence, the interested reader is referred to Borkovec, Ray, and Stöber (in press).

²For ease of illustration, the chains of concrete thoughts and vivid images were drawn in parallel. This is not supposed to indicate that there is no time-delay between concrete thoughts and vivid images. The main point of the illustration is the longer delay between abstract thoughts and images when compared to concrete thoughts and images.

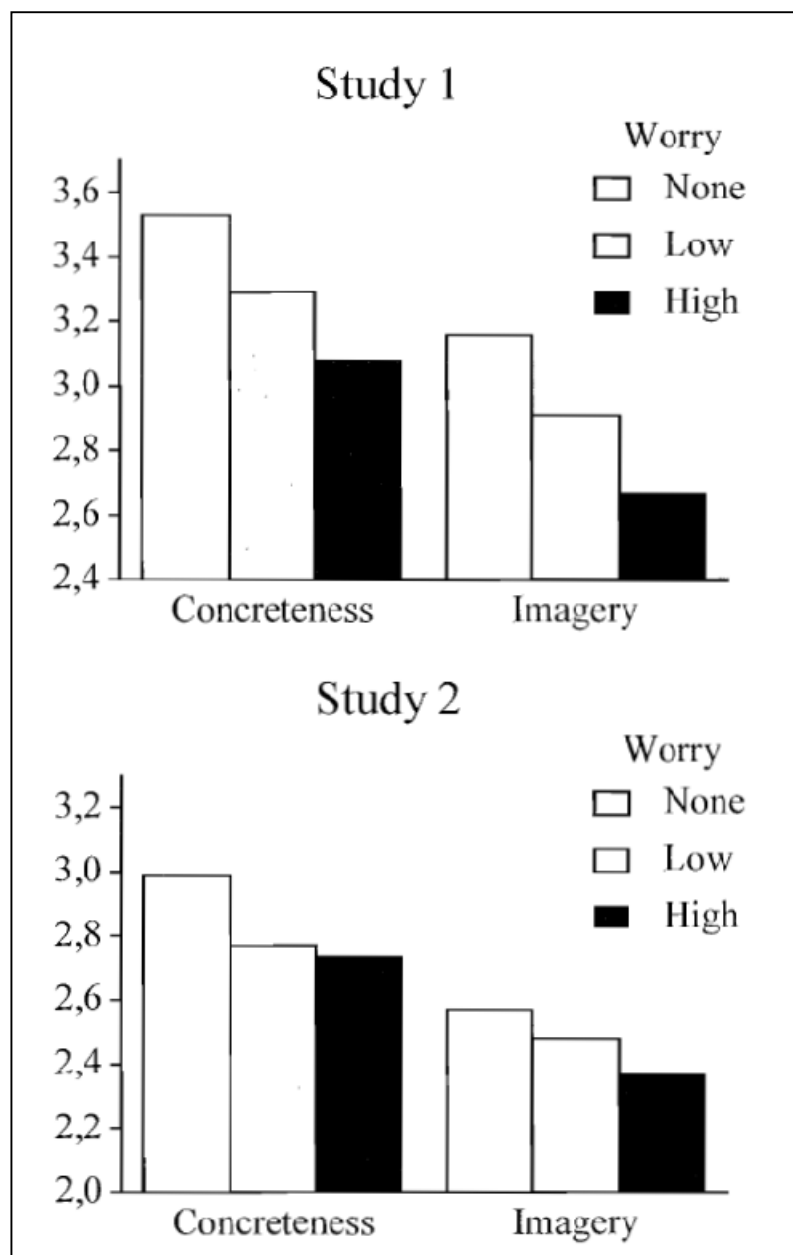

Figure 1. Concreteness and imagery of problem elaborations associated with different degrees of worry (data from Stöber, Tepperwien, & Staak, 1998). Study 1 used problem elaboration charts and Study 2 used catastrophizing interviews to capture problem elaborations. In Study 1 ($N = 60$), the linear trends were significant with $F_s(1, 59) \geq 31.7$, $p_s < .001$. In Study 2 ($N = 60$), the linear trends were significant with $F_s(1, 59) \geq 8.7$, $p_s \leq .004$.

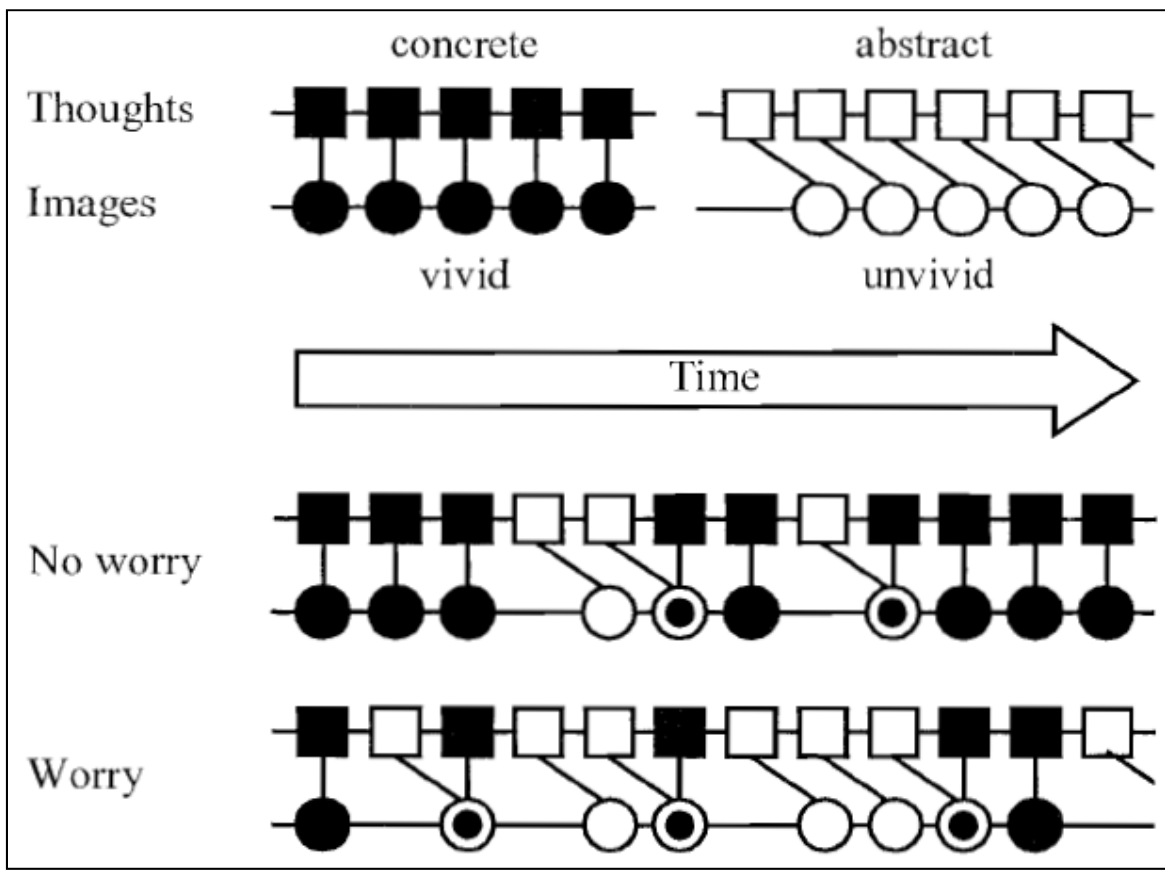

Figure 2. Schematic illustration of the proposed relationship between thoughts, images, concreteness-abstractness, vividness-unvividness, and delay. Top half: Concrete thoughts (■) are associated with vivid images (●). Abstract thoughts (□) are associated with unvivid images (○). Moreover, compared to images associated with concrete thoughts, images associated with abstract thoughts are more delayed. Bottom half: Thoughts and associated images in states of no worry and in worrying.