



Kent Academic Repository

Animah, Isaac and Shafiee, Mahmood (2018) *Condition Assessment, Remaining Useful Life Prediction and Life Extension Decision Making for Offshore Oil and Gas Assets*. Journal of Loss Prevention in the Process Industries, 53 . pp. 17-28. ISSN 0950-4230.

Downloaded from

<https://kar.kent.ac.uk/79743/> The University of Kent's Academic Repository KAR

The version of record is available from

<https://doi.org/10.1016/j.jlp.2017.04.030>

This document version

Author's Accepted Manuscript

DOI for this version

Licence for this version

CC BY-NC-ND (Attribution-NonCommercial-NoDerivatives)

Additional information

Versions of research works

Versions of Record

If this version is the version of record, it is the same as the published version available on the publisher's web site. Cite as the published version.

Author Accepted Manuscripts

If this document is identified as the Author Accepted Manuscript it is the version after peer review but before type setting, copy editing or publisher branding. Cite as Surname, Initial. (Year) 'Title of article'. To be published in *Title of Journal* , Volume and issue numbers [peer-reviewed accepted version]. Available at: DOI or URL (Accessed: date).

Enquiries

If you have questions about this document contact ResearchSupport@kent.ac.uk. Please include the URL of the record in KAR. If you believe that your, or a third party's rights have been compromised through this document please see our [Take Down policy](https://www.kent.ac.uk/guides/kar-the-kent-academic-repository#policies) (available from <https://www.kent.ac.uk/guides/kar-the-kent-academic-repository#policies>).

Accepted Manuscript

Condition assessment, remaining useful life prediction and life extension decision making for offshore oil and gas assets

Isaac Animah, Mahmood Shafiee

PII: S0950-4230(17)30424-2

DOI: [10.1016/j.jlp.2017.04.030](https://doi.org/10.1016/j.jlp.2017.04.030)

Reference: JLPP 3496

To appear in: *Journal of Loss Prevention in the Process Industries*

Received Date: 21 December 2016

Accepted Date: 30 April 2017

Please cite this article as: Animah, I., Shafiee, M., Condition assessment, remaining useful life prediction and life extension decision making for offshore oil and gas assets, *Journal of Loss Prevention in the Process Industries* (2017), doi: 10.1016/j.jlp.2017.04.030.

This is a PDF file of an unedited manuscript that has been accepted for publication. As a service to our customers we are providing this early version of the manuscript. The manuscript will undergo copyediting, typesetting, and review of the resulting proof before it is published in its final form. Please note that during the production process errors may be discovered which could affect the content, and all legal disclaimers that apply to the journal pertain.

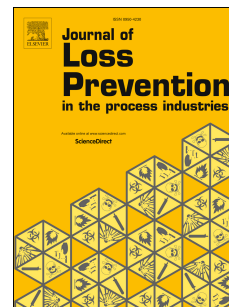

Condition assessment, remaining useful life prediction and life extension decision making for offshore oil and gas assets

Isaac Animah, Mahmood Shafiee *

School of Energy, Cranfield University, College Road, Bedfordshire MK43 0AL, United Kingdom

* Corresponding author, Tel: +44 1234 750111 ; Email: m.shafiee@cranfield.ac.uk

Abstract

Offshore oil and gas assets are highly complex structures comprising of several components, designed to have a lifecycle of 20-25 years of working under harsh operational and environmental conditions. These assets, during their operational lifetime, are subjected to various degradation mechanisms such as corrosion, erosion, wear, creep and fatigue cracks. In order to improve economic viability and increase profitability, many operators are looking at extending the lifespan of their assets beyond the original design life, thereby making life extension (LE) an increasingly critical and highly-discussed topic in the offshore oil and gas industry. In order to manage asset aging and meet the LE requirements, offshore oil and gas operators have adopted various approaches such as following maintenance procedures as advised by the original equipment manufacturer (OEM), or using the experience and expertise of engineers and inspectors. However, performing these activities often provides very limited value addition to operators during the LE period of operation. This paper aims to propose a systematic framework to help operators meet LE requirements while optimizing their cost structure. This framework establishes an integration between three individual life assessment modules, namely: condition assessment, remaining useful life (RUL) prediction and LE decision-making. The benefits of the proposed framework are illustrated through a case study involving a three-phase separator system on a platform which was constructed in the mid-1970s in West Africa. The results of this study affirm the effectiveness of this framework in minimizing catastrophic failures during the LE phase of operations, whilst ensuring compliance to regulatory requirements.

Keywords

Life extension (LE), Asset management, offshore oil and gas, remaining useful life, condition assessment.

1. Introduction

Rejuvenating existing fields through life extension (LE) is regarded as one of the most lucrative strategies for end-of-life management within the offshore oil and gas industry. This has led to an increase in initiatives aiming at extending the service lifespan of existing installations operating within these fields. Over half of the installed structures in both the North Sea and Gulf of Mexico regions have gone past their original design lives of 20–25 years (Ersdal and Selnes, 2010; Ersdal, 2005; Stacey *et al.*, 2008). The operational lives of these assets not only are dependent on environmental loading conditions but also are related to the age of oil field. Hence, for conducting LE analysis, it is imperative to understand the operational life of an asset tied to a field's life.

A typical operational timeline for an offshore oil and gas asset linked to the corresponding field life is illustrated in Figure 1. The asset life begins at time $t = 0$, which indicates the time of commissioning of the field and commencement of operation of the asset. The asset operates until the point $t = l_o$, where l_o denotes the end of original field life and marks the beginning of the life extension phase of operation, owing to the remaining reserves. However, in order to be granted a license until an extended operational period $l_e (> l_o)$, companies are obligated to meet some regulatory requirements. To meet these requirements while simultaneously ensuring profits from the extended period of operations, the asset managers need to address the following fundamental questions:

- 1) How operators can make sure whether their existing assets will be satisfactorily operating after end-of-life or they must be discarded at time $t = l_o$?
- 2) How long will be allowed to extend the life of assets for?
- 3) What type of integrity management programme needs to be put into place to support asset operations over the life extension period?

“Fig. (No. 1)”

Figure 1. The original design life and the extended life of an asset.

In order to provide appropriate answers to above questions, Vaidya and Rausand (2011), Animah *et al.* (2016) and Shafiee *et al.* (2016) suggested, in their respective studies, that it is vital for LE decision makers to estimate the remaining useful life (RUL) of their candidate equipment, as it will enable stakeholders to achieve accurate conclusions during the LE decision-making process. Also, Liao *et al.* (2006) suggested that when ageing degradation is detected, it is important to re-estimate the RUL in order to expedite urgent maintenance decisions and avert possible failures. This is because the preliminary RUL estimated for offshore oil and gas equipment at the design stage is often conservative, since in practice, the actual operational and environmental conditions can be different than those considered during design. Hence, during the LE decision-making process, an enhanced computation process is imperative to determine the actual remaining service life of critical systems, subsystems and components, which may be shorter or longer than the life estimated during design.

The concept of RUL is popular in operational research, reliability and statistics literature, and has real life applications in industries such as material science, biostatistics and econometrics (Si *et al.*, 2011). However, very little research efforts have been carried out towards analysing how RUL prediction can support LE decision making in the offshore oil and gas industry. As a step in that direction, this study proposes a framework that establishes an integration between asset condition assessment, RUL estimation and the LE decision making process. Hence to reiterate, the proposed framework is broken down into three modules, namely: i) condition assessment module, which evaluates the current technical health status of subsystem and components; ii) RUL prediction module, which estimates the maximum duration of time a subsystem or component can operate beyond its original design life; and (iii) LE management module, which establishes the LE management program for the candidate equipment based on RUL results. The framework facilitates assets managers to provide appropriate answers to above-mentioned questions, which help minimize the occurrence of undesirable consequences such as frequent unplanned shutdowns, production losses and environmental damages attributed to unsuspected failures. The benefits of this integrated approach are illustrated through a case study involving a three-phase separator system on an oil platform.

The rest of this paper is structured as follows. Section 2 provides an overview of the state-of-the-art of RUL and its applications within the offshore oil and gas sector. Subsequently, Section 3 highlights the factors that influence RUL prediction for offshore oil and gas assets. Section 4 proposes the integrated condition assessment, RUL prediction and life extension decision making framework. Thereafter, Section 5 presents a case study to demonstrate, test and validate the proposed framework and further discusses the findings. Finally, the conclusions as well as future work directions are presented in Section 6.

2. State-of-the-art of remaining useful life (RUL) in the oil and gas industry

According to Banjevic and Jardine (2006) and Galar *et al.* (2012), the time left before a system fails to operate at acceptable levels is referred to as 'remaining useful life' (RUL). The purpose of RUL is to predict failure time before it occurs, based on current and past conditions of a system (Jardine *et al.*, 2006). RUL is one of the key factors which should be considered when implementing condition monitoring (CM) and prognostic health management (PHM) (Cui *et al.*, 2004; Lee *et al.*, 2006). Wang and Zhang (2008) suggested that precise and proper estimation of equipment RUL is imperative for cost-effective operations as well as prompt maintenance responses. Over the past few years, RUL has emerged as a plausible technical health assessment and decision-making tool for equipment in the offshore oil and gas industry, while keeping life cycle costs low and helping operators meet regulatory requirements.

Literature on RUL estimation to support decision-making in the offshore oil and gas industry encompasses both deterministic and probabilistic methods. RUL approaches are classified either as physics-based approach, data-driven approach, or fusion approach which is a hybrid of the physics and data driven approaches (Varde *et al.*, 2014), while

Ahmadzadeh and Lundberg (2013) also added the experiment-based approach as the fourth classification. A brief discussion and application of each of these approaches is presented below.

2.1 Physics-based approach

The fundamental principle behind the physics-based approach is the formulation of theoretical mathematical models to interpret equipment degradation and damage modelling over time. These models involve the evaluation of failure modes such as crack propagation, wear and corrosion degradation rate of equipment (Galar, *et al.*, 2012). In situations where the accuracy of prediction is crucial and access to data is limited, these physics-based models are suitable and they also take various environmental conditions into account. These models are often expressed in terms of differential equations or partial differential equations and can be solved analytically or numerically due to their level of complexity.

Several studies have so far utilized the physics-based approach for estimating RUL to support the decision making process in the offshore oil and gas industry. Dowdy *et al.* (1988) developed a methodology for predicting the RUL of an in-service mooring chain. Divine *et al.* (1993) employed both qualitative and quantitative approaches for determining the RUL of submersible pumps which were used in the upstream sector of the oil and gas industry. Ammatmulla and Ohl (1997) investigated the corrosion-related, life-limiting conditions of a double-shell tank, and thereafter developed a model to estimate its RUL for an extended service life. Vaidya (2010) reviewed the technical health factors that influence RUL decision making process. The paper suggested Bayesian Belief Network (BBN) as a useful technique for RUL estimation. Vaidya and Rausand (2011) proposed a LE decision making model based on RUL prediction by combining heterogeneous requirements such as degradation modelling, uncertain environmental and operational conditions, uncertain sensor data and expert judgement. The study further concluded that a physics-based approach is the most appropriate technique for supporting LE decision making in the offshore oil and gas industry. Yasseri and Mahani (2016) presented a simple spread-sheet probabilistic procedure to assist engineers in determining the RUL of offshore oil and gas pipelines. This approach was based on reliability index method.

2.2 Data-driven approach

The data-driven approach employs a network of sensors to monitor equipment health status. Data is extracted from sensor signals and some prediction models such as Bayesian models, Cox model, regression models, etc. are then used to estimate the RUL of equipment. In the offshore oil and gas industry, some studies have applied the data-driven approach for estimating RUL to support decision making process. Kallenberg (1998) developed a probabilistic approach to determine the remaining service life of reformer furnace catalyst tubes. The proposed methodology was used to estimate the cumulative probability of failure, time-to-crack initiation and time-to-failure, in terms of furnace operating hours. Kallenberg and Munsterman (2002) used a data-driven approach to present a guideline for estimating the RUL of a catalytic reformer reactor in a petrochemical refinery. Garvey *et al.* (2009) introduced a pattern-recognition-based framework to predict the RUL of a bottom-hole

assembly tool. Gola and Nystad (2011a) utilized statistical methods to calculate the degradation as well as RUL of choke valves in the oil industry. Wilks (2012) demonstrated how corrosion process data could be used in a simulation model to predict the RUL of Coker furnaces in refineries. Nystad *et al.* (2012) scrutinised the problems associated with RUL prediction in the offshore oil and gas industry while using stochastic models. Sharifi *et al.* (2015) forecasted the RUL of pipes using a machine learning technique, derived from thickness measurement, which was able to use the results to alert maintenance engineers regarding the timing to undertake appropriate actions.

2.3 Fusion approach

The fusion approach was suggested because of the limitations in both physics-based approach and data-driven approach (Cheng and Pecht, 2009; Varde *et al.*, 2014). In the fusion approach, the strength of one approach mitigates the weakness of the other. The approach combines sensor acquired data as well as physics-based monitored data to form a new database, in order to predict the RUL of a system. This approach has been deployed for cases in electronics, railway and the aircraft industries (see e.g. Cheng and Pecht, 2009; Galar *et al.*, 2013; Sankavaram *et al.*, 2009; Xu *et al.*, 2014). In the offshore oil and gas industry, few studies have employed fusion approach for estimating RUL to support decision making process. Jaske and Shannon (2007) combined specialised analytical models with a multi-parameter inspection technique to predict the RUL of reformer tubes. Nystad *et al.* (2010) proposed a prognostic model to estimate the RUL of choke valves on a platform subjected to erosion due to sand particles in wells. Gola and Nystad (2011b) proposed a diagnostics-prognostic model for estimating RUL as well as the technical health condition of choke valves on oil and gas platforms.

2.4 Experimental-based approach

The experimental-based approach collects data for RUL estimation through experiments, in order to obtain a better insight and understanding of the lifetime and behaviour of equipment. A typical data collection process for this approach is collating data obtained from accelerated life testing (ALT) of components in laboratories and then using test rigs to simulate the real life conditions. Medjaher *et al.* (2012) substantiated the physics-based approach and data-driven approach, utilizing experimental data obtained from ALT of bearings.

While reviewing the literature on RUL estimation and its application in the offshore oil and gas industry, it is observed that the physics-based and data-driven approach are more popular and have been addressed by many researchers in comparison to other approaches. However, Vaidya and Rausand (2011) suggested that the physics-based approach is the most appropriate approach for LE applications. Hokstad *et al.* (2010) also indicated that due to limited access to good quality data within the offshore oil and gas industry, the physics-based approach is the most suitable approach for LE analysis, since it requires lesser amount of data in comparison to other approaches. However, to the best of the authors' knowledge, few studies have attempted to establish a relationship between condition assessment of critical assets, RUL prediction, and LE decision making.

3. Key influencing factors of remaining useful life (RUL) estimation

The LE decision-making process for structures, systems and components involves a number of key technical, economic and organizational aspects. Identification of these factors provides a strong foundation for making correct decisions concerning data collection, condition assessment, RUL estimation as well as regulatory approval for facilitating continuous operation.

“Fig. (No. 2)”

Figure 2. Key influencing factors of RUL estimation.

In this paper, we classify the factors influencing RUL estimation into input and constraint factors (see Figure 2). A brief overview of the influencing factors of RUL estimation is presented in the next sub-sections.

3.1 Input factors

Vaidya (2010) and Vaidya and Rausand (2011) classified the input factors influencing RUL estimation into three heads: technical health, design records and environmental conditions.

3.1.1 Technical health

The technical health of an asset is gauged or judged using indicators such as technical condition, working life history, environmental history, design records and reliability data (Vaidya and Rausand, 2009). Thus, the technical health of an asset at any given time t can be described as the cumulative knowledge about an asset at that particular time. The technical health status of equipment is interpreted based on its technical conditions and working life history, which are explained briefly below.

Technical condition: The technical condition of assets is the health status, measured based on factors such as environmental conditions and mechanical loadings. According to Vaidya and Rausand (2011), some of these technical condition indicators are more informative when monitored based on a continuous scale, for example, temperature, pressure and noise, while other indicators are discrete such as leakage. Deterioration models are often deployed to determine the health condition of industrial assets.

Working life history/Operational conditions: As oil and gas production field matures, operators will have access to huge amount of operational data or working life data. Therefore, determining the RUL of critical assets at time t to support LE decision making process must involve all operational information gathered from the time of installation to the time of LE decision. The working life information comprises of the age of the asset, degradation records, failure records, condition monitoring information, maintenance and modification information, etc. The sources of these data include the experts' judgement, manufacturers' manuals, operations and maintenance log books, inputs by workforce working on the platforms as well as electronic databases kept by the companies.

3.1.2 Environmental conditions

The environmental conditions predicted at early life stage of the asset life may change over its lifetime as the asset may be subjected to different environmental conditions. This may not only introduce new failure modes but also increase the rate of deterioration growth of existing defects. Therefore, it is essential that the technical health assessment of an asset takes into account the environmental conditions in which the asset is operating. According to Vaidya and Rausand (2011), environmental conditions information must include geographical location of operations, geology of the well, well specific data such as temperature, pressure, viscosity level of the well product, gas content, water content and sand particles. Also, depending on the location of the critical asset, environmental factors such as wave height, current and wind speed may also need to be taken into consideration.

3.1.3 Design history

Some offshore oil and gas assets (i.e. Christmas tree, umbilical, manifold templates, control modules, subsea pumps, subsea separators, pipelines, etc.) are principally designed not to be maintained. Therefore, estimating the RUL of such assets to support LE decision making must take into account the verification of calculations made during the design phase of the asset life cycle. Design phase information typically include material selection information, equipment specification, design codes and standards, design drawings, design life calculations, and engineering variations post design.

3.2 Constraints

The two key constraints that hamper the LE decision making process in offshore oil and gas industry are the lack of access to good quality data for techno-economic feasibility assessment as well as the ageing working force. Hokstad *et al.* (2010) reported that the offshore oil and gas industry lacks data with a high degree of assurance to support the LE decision making process. Also, workforce ageing and lack of trained personnel will negatively impact the success of the LE decision making process. This is because by the time when LE is due, some workforce with vital information may have been retired from active service.

4. Proposed framework for risk based condition and RUL estimation

In this study, a framework to establish the inter-relationship between condition assessment, RUL estimation and LE decision making process is presented. The framework is divided into three modules as shown in Figure 3.

“Fig. (No. 3)”

Figure 3. A process flowchart to estimate RUL for LE decision making

An essential facet in developing the above framework was a strong collaboration among researchers as well as industrial experts, having several years of experience, ranging from 5 to over 30 years, in undertaking LE projects (see Table 1). These experts were drawn in from Norway, UK and Gabon.

“Table (No. 1)”**Table 1. List of industrial participants**

These facilitated in-depth interactions and sharing of expertise by industrial experts formed the basis for RUL data collection as well as for collating the challenges of LE in relation to offshore oil and gas assets. The modes of data collection involved face-to-face semi-structured interviews, on-line surveys as well as review of company internal documents.

4.1 Module 1: Condition assessment module

This module is responsible for assessing the current health status of critical subsystems or components for extended operations. The key tasks under this module are detailed below:

4.1.1 Selection of critical system

Since offshore oil and gas assets comprise of several pieces of static, rotating, electrical and communication systems, it is a technically and financially daunting task to assess the condition of all systems operating on an asset during LE phase of operation. Hokstad *et al.* (2010) suggested that one of the key tasks during LE decision making process is to screen and prioritize critical systems that need special attention. This can be accomplished by excluding pieces of equipment which present low risk to safety and production. Critical systems can be determined using experts' judgement and risk assessment tools such as Failure Mode Effect Analysis (FMEA), Fault Tree Analysis (FTA) and Event Tree Analysis (ETA). This study selected the critical systems for condition assessment by using an in-house prepared list of critical assets, thereby considering equipment having higher risk of failure and greater corresponding consequences during LE phase of operation.

4.1.2 Breakdown of system into manageable units

In order to minimize the risk posed by equipment during LE period of operation, the condition of each subsystem or component of the selected equipment is assessed. The subsystems and components which are in the worst condition and can have major detrimental impacts on reliability, availability, economic loss, safety and the environment, are identified. This is achieved by dividing the selected equipment into manageable subsystems and components, in order to identify safety and production relevant subsystems. Khan and Haddara (2004), Krishnasamy *et al.* (2005) and Khan *et al.* (2008) showed that breaking down a complex system into manageable units helped decision makers focus on subsystems and components whose failure may significantly impact overall system availability, result in economic loss and raise safety and environmental concerns.

4.1.3 Condition assessment

A qualitative condition ranking matrix is used to rank the condition of the subsystems and components. For equipment that have been in use for over 20 years, the probability of failure depends on both the current asset condition and the performance history of individual components over the years. For our case study, the current condition of subsystems or

components in relation to consequence will be assessed based on technical conditions and equipment operability.

A typical asset condition ranking matrix is shown in Table 2. As can be seen, both the probability and the consequences of failure are categorized on a scale from 1 to 5. By applying this equipment condition categorization, the subsystems or components appearing in the red zone will be discarded. This is because these subsystems and components are considered to have failed the evaluation and can no longer perform their intended function in the specific environment. However, those found in the yellow and green zones may be qualified for LE. This process is repeated until all subsystem and components condition gets assessed.

“Table (No. 2)”

Table 2. Condition ranking matrix

As depicted in Table 3, three colour codes are used to indicate potential courses of action. This colour coding methodology has so far used as an equipment condition acceptance criteria for some industries such as electric power, offshore oil and gas and petrochemical industries (Amir and Muttalib, 2014; Hameed and Khan, 2014; Carvalho *et al.*, 2015).

“Table (No. 3)”

Table 3. Categorization of asset conditions

However, it should be noted that different condition factors may influence the construction of the matrix structure. The structure will be dependent on operational philosophy of the respective company. Therefore, depending on the type of organization, the matrix may change from 5×5 to 4×4 or 3×3.

4.2 Module 2: RUL prediction techniques for LE

In this module, we utilize the concept of RUL to predict the maximum duration of time that a subsystem or component can operate beyond its original designated life span, with the purpose of optimizing operations while minimizing catastrophic failures during LE phase of operation. In this case, RUL prediction models can either be probabilistic or deterministic, but must take into account degradation factors, material properties, geometry, operational and environmental conditions, etc. (Vaidya and Rausand, 2011). The fundamental stages of the second module are explained below:

4.2.1 Collect RUL data

The first step of the second module is to collate all relevant RUL data for candidate subsystems or components. This data includes laboratory testing measurements, ALT data, sensor data from monitoring systems, expert knowledge, environmental data and operational information.

4.2.2 Analyse failure mechanism

In real life scenarios, there are more than one failure mechanisms associated with a particular failure mode of subsystems or components operating in the offshore environment. Therefore, it is vital for LE decision makers to explore various failure mechanisms associated with failure modes and choose a dominant failure mechanism that impacts the functionality of the subsystem or component. According to Vaidya and Rausand (2011), the selection of this dominant failure mechanism plays a pivotal role in predicting the RUL of candidate subsystems or components for LE.

4.2.3 Select RUL prediction model

Lifetime estimation models applied in the offshore oil and gas industry to predict RUL of systems and structures include Bayesian models, statistical and stochastic models, computational intelligence models, physics-of-failure models and experts' judgements. After analysis of the possible failure mechanisms associated with subsystems and components, decision makers will be required to select the most appropriate prediction model for the specific application. One of the methods to select the most suitable model is to map the techniques against degradation mechanisms or against the type of data. Table 4 illustrates the mapping of RUL prediction techniques against the possible degradation mechanisms available in the offshore oil and gas sector.

“Table (No. 4)”

Table 4. Technique versus degradation mechanism (adapted from Okoh *et al.*, 2014)

The selection of a suitable lifetime prediction model is contingent on the dominant failure mechanisms associated with the subsystem or components. The different RUL prediction models are briefly explained below:

- *Bayesian model*

The Bayesian technique deals with how prior estimates should be modified in the light of additional information (e.g. information received later or information from another source). In order to estimate, a parameter must be known on the basis of some prior information that was available at that time and known to have a certain value. Since this information is incomplete or of a probabilistic character, there is a ‘prior probability distribution’ of that parameter. Further information with a different value and probability distribution for the same parameter may be now available. Bayesian technique allows the initial estimate (prior distribution) to be modified based on this additional information, in order to obtain a redefined updated estimate (posterior distribution). Vaidya (2010) endorsed that the Bayesian based RUL model presents the opportunity to combine both data from monitoring systems as well as expert judgement, simultaneously for assessment purposes. The selection of prior data is a difficult task during the LE decision making process, as availability of high quality reliable data is always a challenge. In the absence of prior data, the ideal way to select prior distribution will be to start with expert elicitation. For a comprehensive literature on Bayesian approach, readers are referred to Gelman *et al.* (2014).

- *Statistical techniques and stochastic models*

In the case of increasing rate of occurrence of failures (ROCOF), often statistical techniques are used for processing event data to assist in narrowing in on the possible failures. Statistical analysis is also commonly employed for reliability calculations and maintenance optimization, and is derived from available failure records collected over the life time of a system. Some of the techniques used are the counting process, regression analysis and trend test. The MIL-HDBK-189 (1981); MIL-HDBK-217F (1991) and OREDA (2015) handbooks contain statistical data and models for mechanical and electronic/electrical components, respectively. For a more comprehensive review on statistical data driven RUL approach, refer to Si *et al.* (2011). However, Vaidya and Rausand (2011) mentioned in a study that this approach should not be used to estimate RUL of some offshore oil and gas components, due to the paucity of data. On the other hand, stochastic models are used to model equipment degradation process. This approach has the capability to incorporate both dynamic covariate as well as the environmental conditions. Some commonly used stochastic models are regression models, proportional hazard models, Cox regression models and Weibull regression models (Cox, 1972; Kumar and Westberg, 1996; Newby, 1994; Singpurwalla and Wilson, 1995; Vlok et al., 2002; Wang, 2002). A comprehensive review on stochastic models for RUL prediction can be found in Singpurwalla (1995).

- *Computational intelligence models*

Computational intelligence (CI) models adopt techniques such as artificial neural network (ANN), genetic algorithms (GA) and fuzzy logic. The CI techniques require inputs data to achieve the requisite outputs and are often referred to as *Soft Computing* techniques (Okoh *et al.*, 2014). Data obtained from sensors and other monitoring equipment can be utilised by these intelligent models to predict RUL. A comprehensive review on CI models can be found in Siddique *et al.* (2003). Nonetheless, Vaidya and Rausand (2011) implied that it may be impossible to use this approach for predicting RUL of subsea facilities to support LE decision making process. This is primarily due to lack of data availability, the impossibility of obtaining training data as well as the lack of knowledge and trained personnel to use these models.

- *Physic of failure*

Physics of failure (PoF) techniques require parametric data and leverages engineering knowledge on topics such as life cycle assessment, environmental stresses, operating conditions, material selection and degradation mechanisms. The purpose of this RUL prediction technique is to identify possible failure causes and analyse how to eliminate the potential operational failures through design. This technique is based on accurate mathematical principles, which, in turn, provide the details of component life and reliability. It can be applied across a wide range of systems including mechanical and electrical/electronics. According to Vaidya and Rausand (2011), this approach is suitable for predicting RUL of offshore oil and gas systems to support LE decision making. This is because offshore operations are remote and require accurate and precise models to support LE decision making. The PoF techniques are considered as consistent methods for performing LE analysis and require less sensor data for performing possible RUL predictions.

Also, Winning and Belhimer (2006) described data obtained from monitoring sensors in offshore oil and gas industry as unreliable, thereby popularising the PoF technique. The technique is also viable for RUL predictions of components that suffer from degradation such as fatigue cracks, corrosion, erosion and wear.

- *Expert judgement*

This technique is highly reliant on the experience and knowledge gathered by experts over a period of time. In the offshore oil and gas industry, environmental and operational factors change over a period of time with respect to the base factors considered during the time of design. In this case, expert judgement and experience becomes decisive in predicting the RUL of systems and components. This approach has been employed in literature for maintenance optimization and reliability analysis of various systems and components (van Noortwijk et al., 1992). Vaidya and Rausand (2011) advocated the reasons for mandating the engagement of experts for RUL prediction in the offshore oil and gas industry. Data gathered from experts through elicitation can be of great essence in situations where sensor data, observation, experimental and simulated results are unavailable.

4.2.4 Prediction of RUL

At this stage, the RUL of the candidate subsystems or components is estimated for further decision making process.

4.3 Module 3: LE decision making

The third module deals with decision making for future operations based on the RUL results. The suitable LE decisions include: replacement of the entire systems, replacement of some subsystems and components, remanufacturing and refurbishment of the system for continuous operation, etc. In case of a process driven system, the introduction of additional safety and process control measures could also be a possible solution for continuous operation.

5. Application to an offshore process facility

The proposed framework is applied to support LE decision-making for a separator system on offshore platform which was commissioned in the mid-1970s in West Africa. Figure 4 shows a schematic process layout of this separation system found on the offshore platform. The operator is required to extend the operations of the field by an additional 5 years, owing to the remaining reserves.

“Fig. (No. 4)”

Figure 4. A schematic process layout of the separation system

The function of this system is to carry out a three-phase separation process on the well product to segregate oil, water and gas. Separation is primarily achieved by utilizing gravity along with the assistance from application of some chemical and heat processes. Separated gas is routed to the gas dehydration system, and is later transported using pipelines. The

separated water flows into a produced water treatment tank for conditioning. The volume of the vessel is approximately 2.54m^3 which is equivalent to 16BBL and 25.9mm of thickness. At the top of the shell, there are two lifting lugs to support hoisting of the vessel. The inlet, gas outlet, oil outlet, water outlet and other nozzles pass through the shell of the vessel as shown in Figure 4.

5.1 Results and discussion

5.1.1 Module 1

The core function of this system is to separate three-phase well fluids from the three-phase oil and gas producing wells. The system comprises of a horizontal separator vessel and is fitted with primary subsystems and components, along with a dehydrator to remove moisture in the gas. Individual outlets for gas, oil and outlet are provided to discharge each of these components separately. Table 5 contains the breakdown of subsystems and components within the separation system.

“Table (No. 5)”

Table 5. Subsystem and components breakdown

Condition assessment was performed for each of the subsystems and components identified in Table 5. The information used to assess the condition of the subsystems and components was gathered from face-to-face semi-structured interviews with experienced personnel actively involved in LE projects as well as the company’s internal documents on asset integrity. Figure 5 depicts the outcome of the assessment, based on the condition ranking matrix (in relation to Table 2).

“Fig. (No. 5)”

Figure 5. Results of the condition matrix

From Figure 5, applying the condition categorization in Table 3, approximately 60% of components and subsystems in the separation system are qualified for RUL estimation.

5.1.2 Module 2

- RUL data collection

The RUL of the qualified subsystems and components are derived using module 2 of the proposed framework as shown in Figure 3. For example, according to the experts’ opinion, the vessel was designed according to BS 1515: Part 1 (1965) standard, which is now outdated. In addition to that, the material used for manufacturing the vessel was a carbon steel with the grade of carbon steel unknown. The RUL data accumulated for the separator vessel is presented in Table 6. The RUL data for the other 32 subsystems and components were also obtained from monitoring data, taking expert judgement and referring to operational handbooks for the appropriate failure thresholds.

“Table (No. 6)”

Table 6. RUL data collection- *Analysis of failure mechanism*

In addition to the RUL data obtained from various sources, annual sampling and monitoring records such as chloride content, pH level, water content and iron count were also analysed across a 9-year period. From the obtained RUL data and fluid analysis, the most important failure mechanisms were identified as follows:

1. Hydro embrittlement
2. CO₂ corrosion
3. H₂S damages
4. Fatigue cracks
5. Drop object

- *Selection of RUL prediction model*

Based on the acknowledged damage mechanisms, it was apparent that the predominant probable causes of failure were hugely attributed to metal loss due to corrosion as well as fracture due to crack propagation. Hence, it was evident that corrosion and fatigue are the dominant failure mechanisms and RUL must be estimated on the basis of corrosion and fatigue records. A PoF technique was selected in combination with expert judgement to determine the RUL of the subsystems and components. The corrosion model for estimating the RUL is based on API 570 (2016). Hence, the remaining life of a subsystem or component can be calculated using Eq. (1) as follows:

$$RUL = \frac{T_A - T_R}{CR}, \quad (1)$$

where T_A represents the actual thickness measured during inspection, T_R is the design thickness without corrosion allowance and CR represents the measured corrosion rate (mm/year). A subsystem/component is deemed failed if its RUL equals to or below zero. This is expressed mathematically as:

$$\text{Probability of failure} = \Pr(RUL \leq 0). \quad (2)$$

The fatigue crack growth rate is estimated using the Paris law:

$$\frac{da}{dN} = C(\Delta K)^m, \quad (3)$$

where $\frac{da}{dN}$ represents the crack growth rate, ΔK is the stress intensity, C and m are constant parameters related to component's material properties and are obtained through experiments. The number of fatigue cycle to failure N_f is expressed as:

$$N_f = \int_0^N dN = \frac{1}{C} \int_{a_1}^{a_f} \frac{da}{(\Delta K)^m}, \quad (4)$$

where $\Delta K = \beta \Delta \sigma \sqrt{\pi a}$, $\Delta \sigma = \Delta \sigma_{\max} - \Delta \sigma_{\min}$, β is the Young's modulus and depends on components geometry. Thus, expressing the number of cycles to failure N_f in time is defined as:

$$T_f = \frac{2}{(2-m)C(\beta \Delta \sigma \sqrt{\pi})^m} \left(a_{cr} \left[1 - \left(\frac{m}{2} \right) \right] - a_1 \left[1 - \left(\frac{m}{2} \right) \right] \right), \quad (5)$$

where a_1 represents initial crack size and a_{cr} is the critical crack size. A crack beyond a_{cr} will be considered to be a failure. The above model is deterministic and convenient for ascertaining the number of cycles; however, during the LE decision process, probabilistic modelling is essential to handle uncertainties in crack growth. The probabilistic model is expressed as:

$$P[T_f \leq t] = P[a_{cr} - A(t) < 0] = P[T_0 + T_G(a_{cr}) - t < 0], \quad (6)$$

where T_f is the time to failure, t is a specific time, a_{cr} is critical crack depth, $A(t)$ is the crack size at the time t , T_0 is the time for crack initiation and T_G is the time for crack growth to critical path. Figure 6 shows the RUL values for 33 subsystems and components in the separation system that required RUL estimation, to further carry out the LE decision making process.

“Fig. (No. 6)”

Figure 6. RUL estimation results for the separation system

The results indicate that none of the subsystems/components considered for LE are below the anticipated extension period of 5 years. However, the separator vessel's RUL is the range of five to six years, depicting the component with the least extended service life. This indicates that the existing integrity management strategy is suitable for the 32 subsystems and components during LE period of operation; however, the existing integrity management strategy may not guarantee the safety and continual operation of the separator vessel during this period. Therefore, a suitable LE strategy for the vessel will need to be initiated during LE period of operation. The selection of suitable LE strategy must be done, keeping in mind economic and safety perspectives.

5.1.3 Module 3

RUL equal to six years was estimated for the vessel. Hence, the operation of the vessel can safely be extended, without considering replacement for the next five years. However, corrosion control in the vessel must be closely monitored to ensure it is within regulatory safety limits. Therefore, in consultation with experts, it was agreed that a more active corrosion control and mitigation strategy will be devised for short to medium term implementation, while the replacement of this vessel will be considered for long term implementation. Some portions of the LE corrosion management strategy in Table 7 have

been adapted from Nettikaden *et al.* (2014) in order to support LE operation of the separation system.

“Table (No. 7)”

Table 7. LE corrosion mitigation strategy

Implementation of the corrosion mitigation plan in Table 7 could reduce the annual corrosion rate of 0.77mm/year to lower acceptable thresholds which is closer to the regulatory requirements, thereby extending the life of the vessel for another five years. However, if quarterly reviews suggest that the rate of corrosion being controlled does not meet the required threshold of <0.125mm/year, then other options such as replacement must be considered.

6. Conclusions

The prediction of remaining useful life (RUL) for subsystems or components is described as an effective strategy to establish the maximum duration of time that they could operate, beyond their original design life. This is replete with the advantages of enhancing the operational efficiency of a system and prompting quick maintenance response during the extended period of operation. In this study, a new framework establishing an integration between condition assessment, RUL estimation and life extension (LE) decision making process has been proposed. The proposed framework consists of three modules, namely, condition assessment module - aimed at assessing the current health status of critical subsystems or components for extended operations, RUL prediction module - responsible for determining the maximum length of operation of each subsystem or component and the LE decision making module - used for establishing a suitable LE integrity management programme.

In order to test the efficacy of the proposed framework, it was tested with three-phase separation system on a platform which is operating for over 25 years. The results of the case study indicated that the framework provided answers to the questions raised by asset managers, with regard to satisfying LE requirements. It also demonstrated the flexibility for operators to select condition matrix factors that reflect their company's operational criteria, since these may vary significantly from one company to another.

Although the framework has been validated using the case of the three-phase separation system, it is recommended that future work should apply the propose framework to other offshore oil and gas assets such as structural parts, subsea facilities and pipelines to further establish the credibility of the framework. Also, despite the growing interest in LE as a suitable end of life management strategy within the offshore oil and gas industry, very few studies focused on maintenance decision-making beyond the original design life; thus, future research must concentrate on determining the cost-effectiveness of a life extension programme and analysing the corresponding maintenance policies (i.e., frequency and degree/quality of repair) required to enable LE. It is also recommended that the knowledge sharing between operators and consultants should be encouraged and prioritised, since data

collection and collation is the most crucial and challenging tasks during the LE decision making process. This amalgamation of data not only defines the accuracy of results but also impacts the inspection and maintenance schedules.

References

- American Petroleum Institute (API) 570 (2016). *Piping Inspection Code: Inspection, Repair, Alteration, and Rerating of In-service Piping Systems*.
- Ahmadzadeh, F. and Lundberg, J. (2013). Remaining useful life estimation: review. *International Journal of Systems Assurance Engineering and Management*, 5(4), 461–474.
- Amir, M.D.M. and Muttalib, E.S.A. (2014). Health index assessment of aged oil-filled ring main units. In: *8th IEEE International Power Engineering and Optimization Conference*, 24-25 March, Langkawi, Malaysia, pp. 347–351.
- Ammtatmula, R. and Ohl, P. (1997). Double-shell tank remaining useful life estimates. In: *Proceeding of the Corrosion 97*, 9-14 March, New Orleans, Louisiana, USA. pp. 1–12.
- Animah, I., Shafiee, M., Simms, N. and Considine, M. (2016). Techno-economic feasibility assessment of life extension decision for safety critical assets. In *26th European Safety and Reliability Conference (ESREL)*, Glasgow, UK.
- Banjevic, D. and Jardine, A.K.S. (2006). Calculation of reliability function and remaining useful life for a Markov failure time process. *IMA Journal of Management Mathematics*, 17(2), 115–130.
- BS 1515: Part 1. (1965). Specification for fusion welded pressure vessels (advanced design and construction) for use in the chemical, petroleum and allied industries, Part 1: Carbon and ferritic alloy steels.
- Carvalho, E., Tang, F., Allen, E. and Sharma, P. (2015). A case study of asset integrity and risk assessment for subsea facilities and equipment life extension. In *Offshore Technology Conference*, 04-07 May, Houston, Texas, USA pp. 1–12.
- Cheng, S. and Pecht, M. (2009). A fusion prognostics method for remaining useful life prediction of electronic products. In: *IEEE International Conference on Automation Science and Engineering*, 22 - 25 August, Bangalore, India, pp. 102–107.
- Cox, D. (1972). Regression models and life tables (with discussion). *Journal of the Royal Statistical Society*, 34, 187–220.
- Cui, L. R., Loh, H.T. and Xie, M. (2004). Sequential inspection strategy for multiple systems under availability requirement. *European Journal of Operational Research*, 155(1), 170–177.
- Divine, D.L., Lannom, R.W. and Johnson, R.A. (1993). Determining pump wear and remaining life from electric submersible pump test curves. *SPE Production & Facilities*, 8(3), 217–221.
- Dowdy, M.J., Graham, D.J. and Diamond, M. (1988). A method for evaluating and extending the useful life of in-service anchor chain. In: *Offshore Technology Conference*, 2-5 May, Houston, Texas, pp. 333–341.
- Ersdal, G. and Selnes, P.O. (2010) Life extension of aging petroleum production facilities offshore. In: *SPE International Conference on Health, Safety and Environment in Oil and Gas Exploration and Production*, 12–14 April, Rio de Janeiro, Brazil, pp. 1–14.
- Ersdal, G. (2005) *Assessment of existing offshore structures for life extension*. PhD thesis, University of Stavanger, Norway.
- Galar, D., Kumar, U., Lee, J. and Zhao, W. (2012). Remaining useful life estimation using time trajectory tracking and support vector machines. *Journal of Physics: Conference Series* (Vol. 364, p. 12063). IOP Publishing.
- Galar, D., Kumar, U., Villarejo, R. and Johansson, C.-A. (2013). Hybrid prognosis for railway health assessment: an information fusion approach for PHM deployment. In: *Prognostic and System Health Management*, 8-11 September, Milan, Italy, pp. 1-6.
- Garvey, D.R., Baumann, J., Lehr, J., Hughes, B. and Hines, J.W. (2009). Pattern recognition-based remaining useful life estimation of bottomhole assembly tools. In: *SPE/IADC Drilling Conference and Exhibition*. 17-19 March, Amsterdam, The Netherlands, pp. 82–89.
- Gelman, A., Carlin, J.B., Stern, H.S. and Rubin, D.B. (2014). *Bayesian data analysis*. Boca Raton, FL, USA: Chapman & Hall/CRC.
- Gola, G. and Nystad, B.H. (2011a). Comparison of time- and state-space non-stationary gamma processes for estimating the remaining useful life of choke valves undergoing erosion. In: *24th International Conference on Condition Monitoring and Diagnostic Engineering Management (COMADEM)*, 30 May–1 June, Stavanger, Norway.
- Gola, G. and Nystad, B.H. (2011b). From measurement collection to remaining useful life estimation : defining a diagnostic-prognostic frame for optimal maintenance scheduling of choke valves undergoing erosion. In:

- Annual Conference of the Prognostics and Health Management society*, 25-29 September, Montreal, Canada, pp. 1–8.
- Hameed, A. and Khan, F. (2014). A framework to estimate the risk-based shutdown interval for a processing plant. *Journal of Loss Prevention in the Process Industries*, 32(1), 18–29.
- Hokstad, P., Habrekke, S., Johnsen, R. and Sangesland, S. (2010). *Ageing and life extension for offshore facilities in general and for specific systems* (Vol. A15322). Norway: SINTEF Technology and Society.
- Jardine, A.K.S., Lin, D. and Banjevic, D. (2006). A review on machinery diagnostics and prognostics implementing condition-based maintenance. *Mechanical Systems and Signal Processing*, 20(7), 1483–1510.
- Jaske, C.E. and Shannon, B.E. (2007). Current issues in optimizing the useful life of reformer tubes. In: *Proceeding of the Corrosion Conference and Expo*, 11-15 March, Nashville, Tennessee. pp. 1–13.
- Kallenberg, G.P. (1998). Remaining life assessment of steam/methane and hydrogen reformer furnace tubes. In: *NACE International Conference*, 22-27 March, San Diego, California, USA. pp. 1–10.
- Kallenberg, G.P. and Munsterman, T. (2002). Remaining life assessment of catalytic reforming reactors. In: *NACE International Conference*, 7-11 April, Denver, Colorado, USA.
- Khan, F. I. and Haddara, M. (2004). Risk-based maintenance (RBM): A new approach for process plant inspection and maintenance. *Process Safety Progress*, 23(4), 252–265.
- Khan, F. I., Haddara, M. and Krishnasamy, L. (2008). A new methodology for risk-based availability analysis. *IEEE Transactions on Reliability*, 57(1), 103–112.
- Krishnasamy, L., Khan, F. and Haddara, M. (2005). Development of a risk-based maintenance (RBM) strategy for a power-generating plant. *Journal of Loss Prevention in the Process Industries*, 18(2), 69–81.
- Kumar, D. and Westberg, U. (1996). Proportional hazards modeling of time-dependent covariates using linear regression: a case study. *IEEE Transactions on Reliability*, 3(45), 386–392.
- Lee, J., Ni, J., Djurdjanovic, D., Qiu, H. and Liao, H. (2006). Intelligent prognostics tools and e-maintenance. *Computers in Industry*, 57(6), 476–489.
- Liao, H., Zhao, W. and Guo, H. (2006). Predicting remaining useful life of an individual unit using proportional hazards model and logistic regression model. In: *IEEE Annual Reliability and Maintainability Symposium*, 23-26 Jan, Washington, DC, USA, pp. 127–132.
- Medjaher, K., Tobon-Mejia, D.A. and Zerhouni, N. (2012). Remaining useful life estimation of critical components with application to bearings. *IEEE Transactions on Reliability*, 61(2), 292–302.
- MIL-HDBK-189. (1981). *Military Handbook Reliability Growth Management*, Department of Defence, Washington, DC, USA.
- MIL-HDBK-217F. (1991). *Military Handbook Reliability Prediction of Electronic Equipment*, Department of Defence, Washington, DC, USA.
- Nettikaden, V.C., Ifezue, D. and Tobins, F.H. (2014). Assessment of corrosion damage in a finger-type slug catcher. *Journal of Failure Analysis and Prevention*, 14(1), 43–54.
- Newby, M. (1994). Perspective on Weibull proportional-hazards models. *IEEE Transactions on Reliability*, 2(43), 217–223.
- Nystad, B.H., Gola, G. and Hulsund, J.E. (2012). Lifetime models for remaining useful life estimation with randomly distributed failure thresholds. In *European Conference of Prognostics and Health Management Society*, 3-5 July, Dresden, Germany, pp. 1–7.
- Nystad, B. H., Gola, G., Hulsund, J. E. and Roverso, D. (2010). Technical condition assessment and remaining useful life estimation of choke valves subject to erosion. In: *Annual Conference of the Prognostics and Health Management Society*, 10-14 October, Portland, USA, pp. 1–9.
- Okoh, C., Roy, R., Mehnen, J. and Redding, L. (2014). Overview of Remaining Useful Life prediction techniques in Through-life Engineering Services. *Procedia CIRP*, 16, 158–163.
- Sankavaram, C., Pattipati, B., Kodali, A., Pattipati, K., Azam, M., Kumar, S. and Pecht, M. (2009). Model-based and data-driven prognosis of automotive and electronic systems. In: *IEEE International Conference on Automation Science and Engineering*, 22-25 August, Bangalore, India, pp. 96–101.
- Sharifi, M., Yao, K., Raghavendra, S., Ershaghi, I., House, R. and Jacques, B. (2015). Prediction of remaining life in pipes using machine learning from thickness measurement. In: *SPE Western Regional Meeting*, 27-30 April, Garden Grove, California, USA, pp. 1–9.
- Shafiee, M., Animah, I. and Simms, N. (2016). Development of a techno-economic framework for life extension decision making of safety critical installations. *Journal of Loss Prevention in the Process Industries*, 44, 299–310.
- Si, X.S., Wang, W., Hu, C.H. and Zhou, D.H. (2011). Remaining useful life estimation - A review on the statistical data driven approaches. *European Journal of Operational Research*, 213(1), 1–14.
- Siddique, A., Yadava, G.S. and Singh, B. (2003). Applications of artificial intelligence techniques for induction machine stator fault diagnostics: review. In: *4th IEEE International Symposium Diagnostics for Electric Machines, Power Electronics and Drives*, 24-26 August, Georgia USA, pp. 29–34.

- Singpurwalla, N.D. (1995). Survival in dynamic environments. *Statistical Science*, 1(10), 86-103
- Singpurwalla, N.D. and Wilson, S.P. (1995). The exponentiation formula of reliability and survival: Does it always hold? *Lifetime Data Analysis*, 1(2), 187–194.
- Stacey, A., Birkinshaw, M. and Sharp, J.V. (2008) Life extension issues for ageing offshore installations. In: *Proceedings of the 27th International Conference on Offshore Mechanics and Arctic Engineering (OMAE)*, June 15–20, Estoril, Portugal, pp. 199–215.
- Vaidya, P. (2010). Prognosis - subsea oil and gas industry. *Annual Conference of the Prognostics and Health Management Society*, 10 - 14 October, Portland, USA, pp. 1–10.
- Vaidya, P. and Rausand, M. (2009). Life extension of machinery in the oil and gas industry. In *Proceedings of European Safety and Reliability Conference (ESREL)*, 7-10 September, Prague, Czech Republic, pp. 2223-2230.
- Vaidya, P. and Rausand, M. (2011). Remaining useful life, technical health, and life extension. *Journal of Risk and Reliability*, 225(2), 219–231.
- van Noordwijk, J.M., Dekker, R., Cooke, R.M. and Mazzuchi, T.A. (1992). Expert judgment in maintenance optimization. *IEEE Transactions on Reliability*, 41(3), 427–432.
- Varde, P.V., Tian, J. and Pecht, M.G. (2014). Prognostics and health management based refurbishment for life extension of electronic systems. In: *IEEE International Conference on Information and Automation*, 28 - 30 July, Hailar, Hulun Buir, China. pp. 1260–1267.
- OREDA (2015). *Offshore Reliability Data Handbook*, 6th edition, Volume I - Topside Equipment and Volume, 2 - Subsea Equipment, SINTEF Energy, Norway.
- Vlok, P.J., Coetzee, J.L., Banjevic, D., Jardine, A.K.S. and Makis, V. (2002). Optimal component replacement decisions using vibration monitoring and the proportional-hazards model. *Journal of the Operational Research Society*, 2(53), 193–202.
- Wang, W. (2002). A model to predict the residual life of rolling element bearings given monitored condition information to date. *IMA Journal of Management Mathematics*, 1(13), 3–16.
- Wang, W. and Zhang, W. (2008). An asset residual life prediction model based on expert judgments. *European Journal of Operational Research*, 188(2), 496–505.
- Wilks, G.W. (2012). Remaining life assessments of refinery coker furnace tubes. In: *NACE International Conference*, 11-15 March, Salt Lake City, Utah, pp. 1–16.
- Winning, I.G. and Belhimer, E. (2006). Practical Aspects of Field Monitoring of Corrosion. In: *NACE International Conference*, 12-16 March, San Diego, California, USA, pp. 1-18.
- Xu, J., Wang, Y. and Xu, L. (2014). PHM-oriented integrated fusion prognostics for aircraft engines based on sensor data. *IEEE Sensors Journal*, 14(4), 1124–1132.
- Yasserli, S.F. and Mahani, R.B. (2016). Remaining useful life (RUL) of corroding pipelines. In: *26th International Ocean and Polar Engineering Conference*, 26 June - 2 July Rhodes, Greece, pp. 390–397.

Table 1. List of industrial participants

Participant	Background	Years of experience
P1	Researcher	30
P2	Regulator	8
P3	Chief Engineer- Technical safety	20
P4	Oil and gas facility manager	5
P5	Consultant	20
P6	Safety case manager	10
P7	Offshore facility manager	5

Table 2. Condition ranking matrix

Probability of occurrence category						
Frequent	5	(2) Uncertain	(3) Poor	(3) Poor	(3) Poor	(3) Poor
Probable	4	(1) Good	(2) Uncertain	(2) Uncertain	(3) Poor	(3) Poor
Occasional	3	(1) Good	(2) Uncertain	(2) Uncertain	(2) Uncertain	(3) Poor
Remote	2	(1) Good	(1) Good	(2) Uncertain	(2) Uncertain	(2) Uncertain
Extremely unlikely	1	(1) Good	(1) Good	(1) Good	(1) Good	(1) Good
Consequence category		1	2	3	4	5
Operation condition		Minor maintenance activity	Less shutdown with less repair cost and less implication on system availability	Moderate shutdown with moderate repair cost and moderate implication on system availability	Longer shutdown with more significant cost of repair with implications on system availability	Permanent shutdown
Production loss		<5%	5-10%	10-30%	30-60%	>60%
Material degradation		No	Slight	Obvious	Serious	Extreme
Fatigue cracks		No flaw	$0 < \alpha \leq 0.001$	$0.001 < \alpha \leq 0.03$	$0.03 < \alpha \leq 0.15$	$\alpha > 0.15$
Corrosion		$\eta \leq 0.005$	$0.005 < \eta \leq 0.03$	$0.03 < \eta \leq 0.08$	$0.08 < \eta \leq 0.25$	$\eta > 0.25$

α and η represent, respectively, the corrosion factor and the fatigue crack factor

Table 3. Categorization of asset conditions

Class	Description
Poor	The condition of the subsystem or component is significantly outside design limits and should be discarded.
Uncertain	The condition of the subsystem or component may be outside design limit or unknown and RUL should be determined
Good	The condition of the subsystem or component is within design limit and RUL must be determined.

Table 4. Technique versus degradation mechanism (adapted from Okoh *et al.*, 2014)

Degradation mechanism	Bayesian model	Statistical techniques and stochastic models	Computational intelligence models	Physic of failure	Expert Judgement
Fatigue	×	×	×	×	-
Wear	×	×	×	×	-
Deformation	-	-	-	×	×
Corrosion	×	×	×	×	-

Table 5. Subsystem and components breakdown

Separation system		
Subsystem and component description	Subsystem/component	Number
Vessel	Component	1
Piping	Component	35
Pump	Subsystem	2
Produced water treatment tank	Component	1
Surge tank	Component	1
Gas dehydrator	Subsystem	1
Pressure relief valve	Subsystem	3
Drain valve	Subsystem	1
Other valves	Subsystem	8
Export lines	Subsystem	2
Total		55

Table 6. RUL data collection

Description	Value
Design pressure	51barg
Current operating pressure	25barg
Measured thickness	25.9mm
Required minimum thickness per design	21.3mm
Average corrosion rate	0.77mm/year
Targeted corrosion rate	<0.125mm/year
CO ₂ partial pressure	1.93–2.89barg

Table 7. LE corrosion mitigation strategy

Responsible officer	Action	Critical subsystem	Frequency	Threshold	Corrective actions
Process technician	Monitor water content in well product	A1.A	Monthly/every sphere run	<20% vol.% water	Notify asset integrity manager
Process technician	Monitor iron count in the vessel fluid	A1.A	Monthly	<50ppm	Notify asset integrity manager
Process technician	Monitor pH level of well product	Well	Monthly	7.0<pH<9.0	Notify asset integrity manager if pH is beyond threshold
Process technician	Monitor chloride content in produced water	A1.E	Monthly/every sphere run	<10,000ppm	Notify asset integrity manager
Corrosion engineer	Inject inhibitor	Glycol/ME G plant	Monthly	>100ppm	If lower than threshold increase dosage
Corrosion engineer	On-line degradation monitoring	A1.E	Annually	<0.125mm/year	If greater than threshold. Notify asset integrity manager
Asset integrity management team	Review of results	-	Quarterly	-	If threshold is above regulatory limit, replacement option should be considered

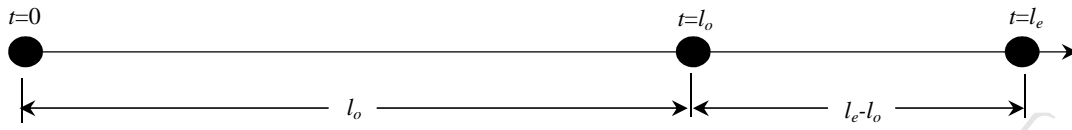

Figure 1. The original design life and the extended life of an asset.

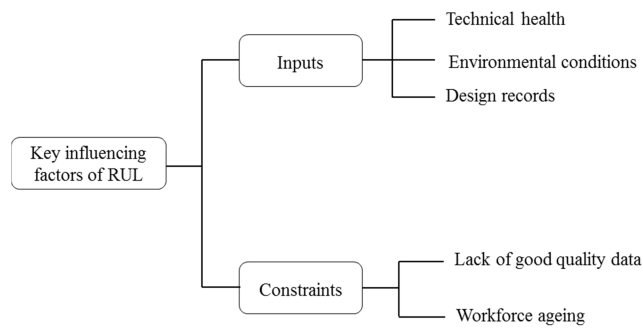

Figure 2. Key influencing factors of RUL estimation.

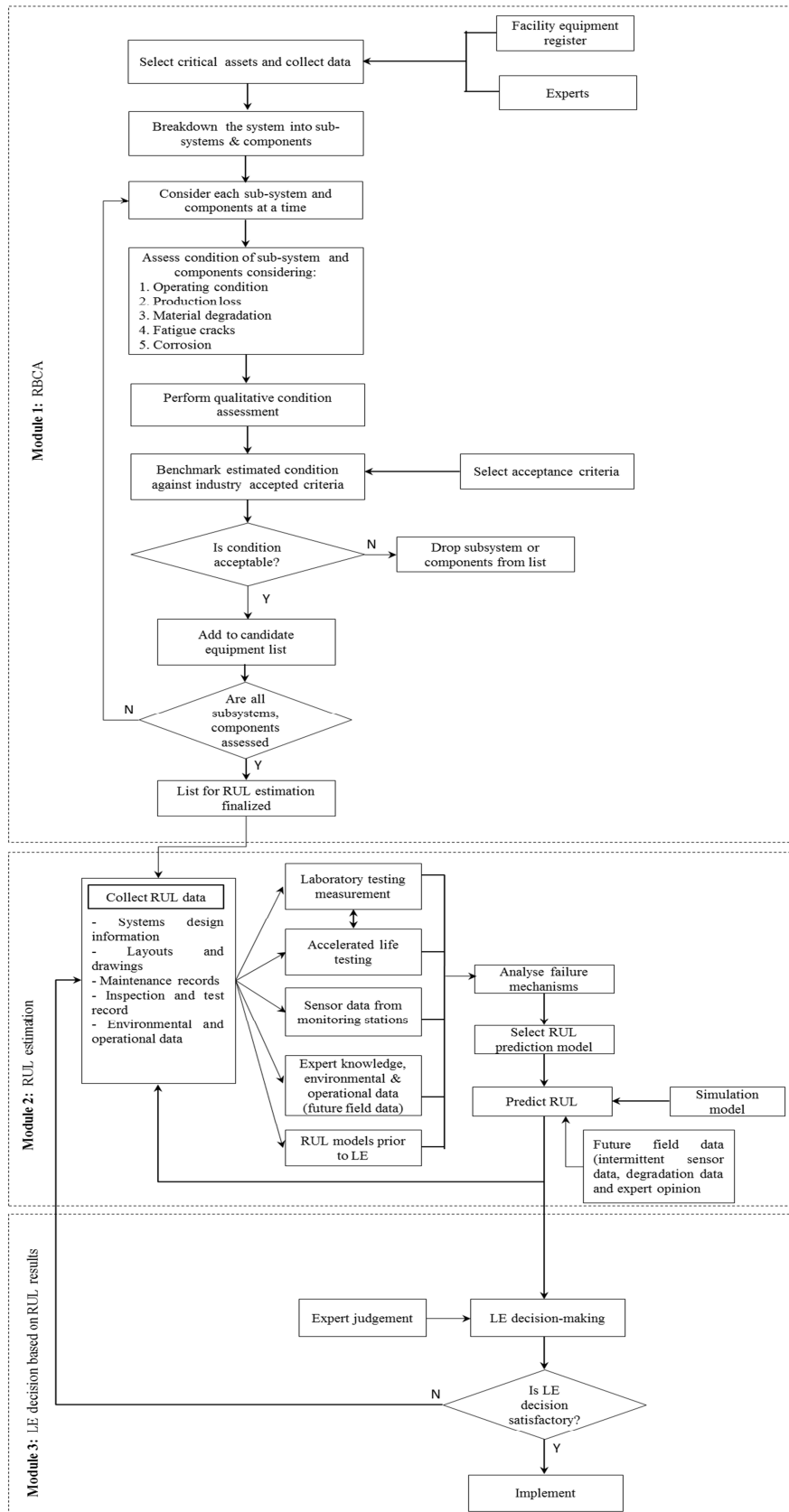

Figure 3. A process flowchart to estimate RUL for LE decision making

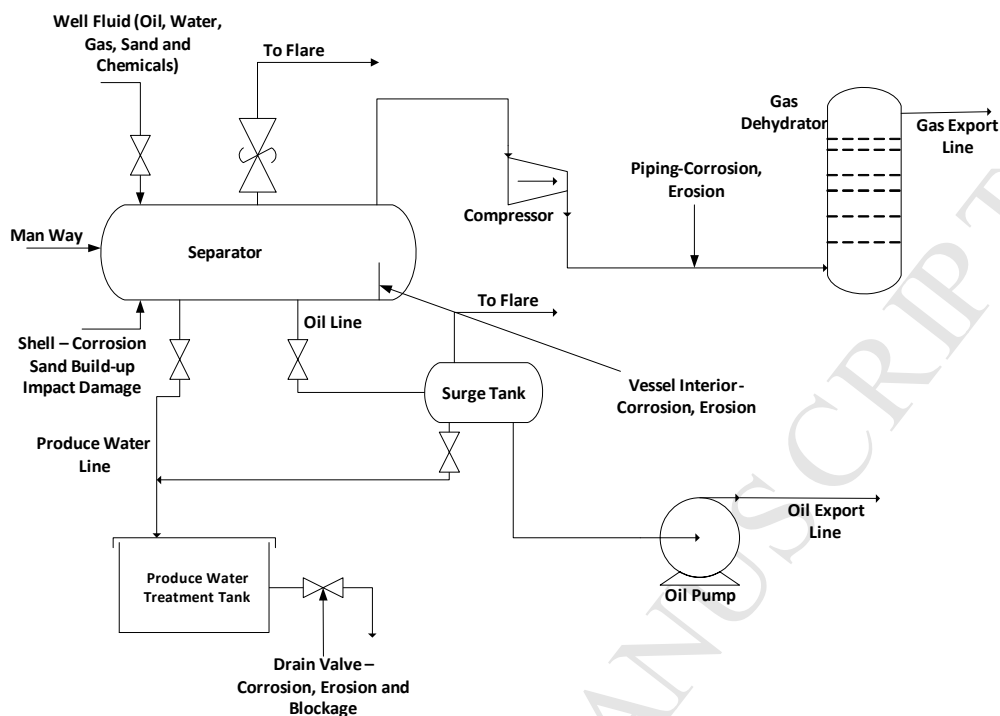

Figure 4. A schematic process layout of the separation system

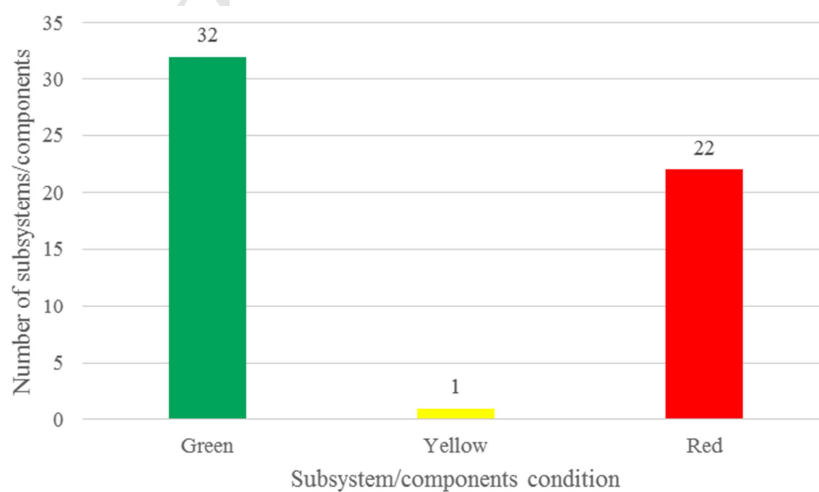

Figure 5. Results of the condition matrix

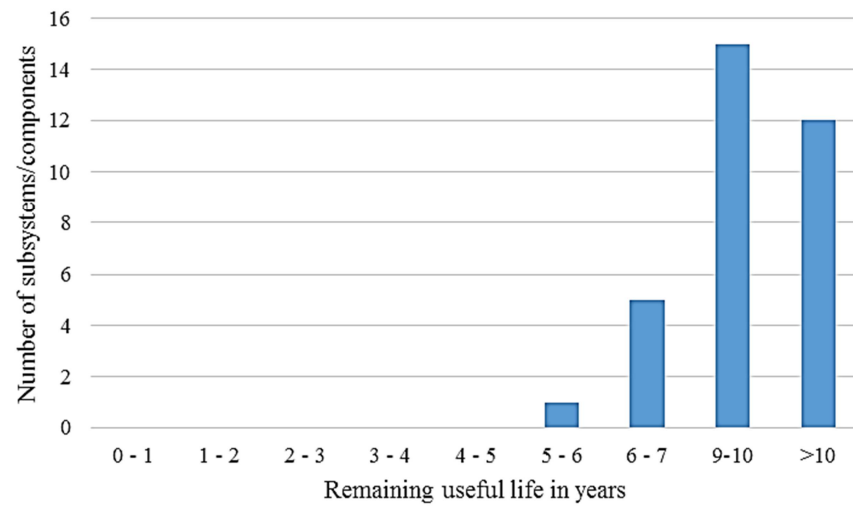

Figure 6. RUL estimation results for the separation system

RESEARCH HIGHLIGHTS

- To propose a systematic framework to help offshore oil and gas operators meet life extension (LE) requirements;
- An integration between three individual life assessment modules, namely: condition assessment, remaining useful life (RUL) prediction and LE decision-making.
- A case study involving a three-phase separator system on a platform.