



# Kent Academic Repository

**Habib, Usman, Steeg, Matthias, Stohr, Andreas and Gomes, Nathan J. (2019)**  
***Single Radio-over-Fiber Link and RF Chain-based 60GHz Multi-beam Transmission.***  
**Journal of Lightwave Technology, 37 (9). pp. 1974-1980. ISSN 0733-8724.**

## Downloaded from

<https://kar.kent.ac.uk/72444/> The University of Kent's Academic Repository KAR

## The version of record is available from

<https://doi.org/10.1109/JLT.2019.2896778>

## This document version

Author's Accepted Manuscript

## DOI for this version

## Licence for this version

UNSPECIFIED

## Additional information

## Versions of research works

### Versions of Record

If this version is the version of record, it is the same as the published version available on the publisher's web site. Cite as the published version.

### Author Accepted Manuscripts

If this document is identified as the Author Accepted Manuscript it is the version after peer review but before type setting, copy editing or publisher branding. Cite as Surname, Initial. (Year) 'Title of article'. To be published in *Title of Journal*, Volume and issue numbers [peer-reviewed accepted version]. Available at: DOI or URL (Accessed: date).

## Enquiries

If you have questions about this document contact [ResearchSupport@kent.ac.uk](mailto:ResearchSupport@kent.ac.uk). Please include the URL of the record in KAR. If you believe that your, or a third party's rights have been compromised through this document please see our [Take Down policy](https://www.kent.ac.uk/guides/kar-the-kent-academic-repository#policies) (available from <https://www.kent.ac.uk/guides/kar-the-kent-academic-repository#policies>).

# Single Radio-over-Fiber Link and RF Chain-based 60GHz Multi-beam Transmission

Usman Habib, *Student Member, IEEE*, Matthias Steeg, Andreas Stöhr, *Senior Member, IEEE* and Nathan J. Gomes, *Senior Member, IEEE*

**Abstract** An efficient multi-user transmission scheme at 60 GHz using a single-feed Leaky Wave Antenna (LWA) and hence requiring only a single Radio-over-Fiber link and single RF chain is presented. A Subcarrier Multiplexed (SCM) signal carrying the different users' data is transported over 2.2km of optical fiber and then upconverted to the 60 GHz band for transmission to multiple spatially separated users through the beam steering characteristics of the LWA. An overall sum data rate, the combined rate from all users, of 10.6 Gb/s using 16-QAM modulation serving 10 users over a transmission bandwidth of 3.05 GHz or 20 users with QPSK over 6.1 GHz span, is achieved experimentally. The theoretical sum data rates for 6.1 GHz bandwidth for different numbers of users are calculated, considering the SNR degradation due to the angularly dispersed LWA beam, showing that data rates over 30 Gb/s can be obtained. Finally, a system design that improves coverage and spectrum efficiency through operating multiple LWAs with a single RF chain is demonstrated.

**Index Terms**—Radio-over-Fiber (RoF), Subcarrier Multiple Access (SCMA), Spatial Division Multiple Access (SDMA), Leaky Wave Antenna (LWA)

## I. INTRODUCTION

Future mobile networks are anticipated to have multiple 60GHz Remote Antenna Units (RAUs) within a small area, as large numbers of users and devices are expected to connect to the network [1], providing adequate coverage that is mainly limited by the high propagation loss at 60GHz. The RAU design considerations should include low cost, low complexity and a capability to serve multiple spatially distributed users. Multi-beam operation from the RAU will require a large number of RF chains, which can be reduced using techniques such as optimized beam allocation [2] and hybrid beamforming [3], but at the cost of increased computational complexity. However, the hardware for multi-user transmission can still require a considerable number of RF chains (each having multiple, high-cost mmW components). For such systems, use of an analog Radio-over-fiber (RoF) fronthaul can provide several advantages such as low loss transmission with ultra-high capacity [4] and centralized access for the RAUs [5]-[7], and RoF-supported multi-user transmission has been demonstrated using multiple transmit antennas at the RAU, each generating a single directional beam and serving a single user [8]-[10]. Use of a single laser source in RoF transport for multiple data channels can reduce the cost of operation as it does not require optical filters at the RAU to separate wavelengths and avoids issues related to wavelength drift of multiple laser sources [11], [12].

Manuscript received November 30, 2018. This work was supported by the European Union's Horizon 2020 Research and Innovation programme under contract 643297 (RAPID).

U. Habib and N. J. Gomes are with the Communication Research Group, University of Kent, Canterbury UK (uh23@kent.ac.uk).

M. Steeg and A. Stöhr are with the University of Duisburg-Essen, Duisburg, Germany.

In this work, a low cost and low complexity technique for multi-user transmission is presented which makes use of a Subcarrier Multiplexing (SCM) composite signal to carry data for multiple users and the beamsteering characteristics of a frequency-selective Leaky-Wave-Antenna (LWA) to generate multiple beams. The use of Subcarrier Multiplexing (SCM) [13]-[17] with a single RoF transport link can provide high system capacity and support for large numbers of users [18], [19]. The LWA is a steerable directive antenna which operates in the 60GHz-band [20] and requires only a single feed input port. The LWA scans its beam angle with changing RF, effectively converting different RFs in the SCM to Spatial Division Multiple Access (SDMA). The proposed approach involves the advantages of Subcarrier Multiple Access (SCMA), such as independence of each channel to modulation format and not needing synchronization between different channels [21], as well as those of SDMA. A scenario representing the simplicity of the proposed system in a dense user environment is shown in Fig. 1, where  $N$  number of subcarriers carrying Gb/s data rate future applications [22] are transmitted to the intended users through multiple beams using a single RoF link and single RF chain. Demonstration of serving one user per beam has been performed in this work, but multiple users per beam could be served with techniques such as Time Division Multiple Access (TDMA).

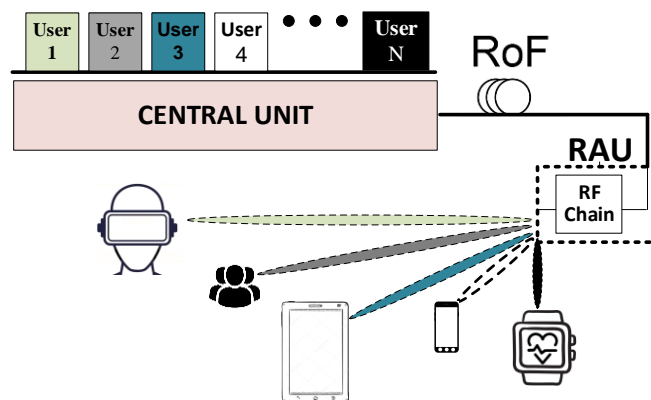

Fig. 1. Single RAU architecture with Array antenna or Multiple Antennas to serve Multiple Users simultaneously

This paper is organized as follows: a description of the LWA and experimental setup for multi-user transmission is given in Section II, while a demonstration of serving a large number of users via a single RF chain is described in Section III. Section IV presents an experimental analysis of SNR degradation of a large bandwidth signal due to the LWA's beamsteering characteristics and a theoretical calculation of maximum data rate for a specific transmission bandwidth. A demonstration to improve coverage and spectrum efficiency with multiple LWAs is performed in Section V. The Conclusion follows, in Section VI.

## II. MULTI-USER TRANSMISSION IN 60GHZ-BAND

### A. Beamsteering through LWA Transmission

Multi-user transmission is achieved through generation of a composite SCM signal which allocates different user data to different subcarrier frequencies. The SCM signal is upconverted to the 60GHz-band and transmitted through the fabricated LWA which performs passive steering of different carrier frequencies in different spatial directions. The designed LWAs have 20GHz bandwidth, from 50GHz to 70GHz, with a single feed [23]. Each consists of an array of substrate integrated waveguide-fed half-wave microstrip antennas which are fabricated through a cost effective PCB process. The LWAs considered for this work are a 12x1 LWA consisting of 12 unit cells and a 20x1 LWA with an array of 20 unit cells. A 12x1 LWA supported by a brass bracket and V-type end launch connectors is shown in Fig. 2. In each unit cell of the substrate-integrated waveguide (SIW) based periodic LWA, a microstrip line is inset, which acts as the radiating element. The array incorporates a frequency dependent phase difference in the wave as it propagates through the consecutive cells. Thus, each subcarrier in the SCM signal, upconverted to a different RF, is radiated at a different beam angle and therefore transmitted in a different spatial direction. The HFSS® simulation results of the 12x1 LWA radiation patterns for different central frequencies are shown in Fig. 2, showing that the LWA has a directional gain of 14.5dB (main lobe to first side lobe level) and provides a beamsteering of around  $1.86^\circ$  when the carrier frequency changes by 1GHz.

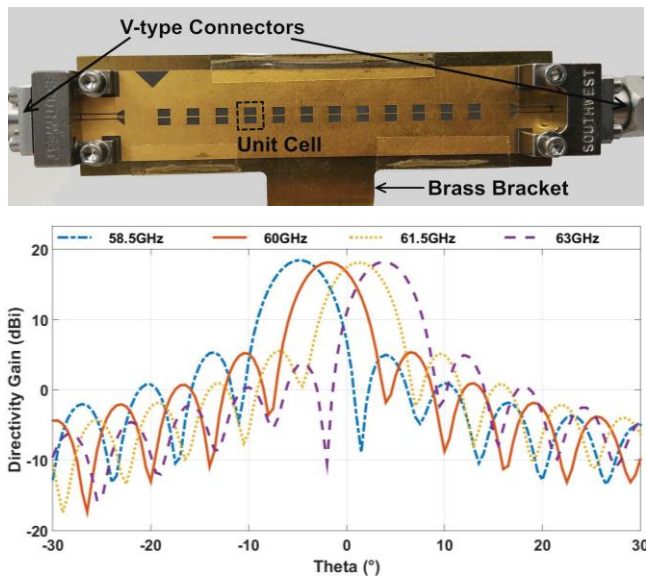

Fig. 2. Leaky Wave Antenna with 1.85mm End Launch Connector HFSS® (top) Simulated Beam Pattern for 12x1 LWA for different V- band frequencies (bottom)

As the number of cells increases for the LWA, the beamwidth becomes narrower and gain per beam increases. A comparison of the radiation pattern (and equivalent frequency response for a fixed transmission angle) of the two LWAs is shown in Fig. 3. This shows that the 20x1 LWA has 2dB greater directional gain per beam and narrower beamwidth. The estimated 3dB bandwidth from the antenna patterns (shown in Fig. 3 for the two LWAs) is 2.91GHz for 12x1 LWA and 1.8GHz for 20x1 LWA. The verification of simulation results is performed by  $S_{21}$  measurements for the two LWAs using a Vector Network Analyzer (VNA, Anritsu 37369c). The 3dB bandwidth from the measured  $S_{21}$  response

of the 12x1 and 20x1 LWAs was found to be 2.83GHz and 2GHz, respectively, in reasonable agreement with the simulation results.

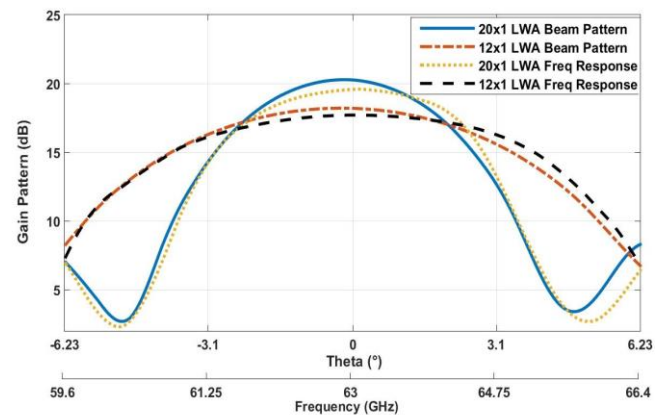

Fig. 3. Beam pattern versus angle relative to a fixed transmission angle and frequency response for 12x1 and 20x1 LWAs

### B. System Setup

Fig. 4 shows the experimental system setup. Multiple user signals are generated in MATLAB/Simulink at different Intermediate Frequencies (IFs) and added together to form a composite SCM signal. Each user signal employs OFDM modulation with 512 IFFT size, 392 data subcarriers, 112 guard subcarriers (zero padding) and 1/8 CP size. The OFDM signal is generated in Simulink using the standard blocks of the Communications System Toolbox including random integer generator, QAM and OFDM modulator. An Arbitrary Waveform generator (AWG, Tektronix 70001A) is used to generate the composite analog waveform with different IFs, which directly modulates a Distributed Feedback Laser (DFB). After 2.2km SMF transport to the RAU, a photodiode is used to recover the composite SCM signal which is amplified by 17dB, passed through a differential balun and DC blocker (8.5dB loss) and upconverted to the 60GHz-band using an integrated 60GHz transmitter (Gotmic gTSC0020). The integrated transmitter uses an LO of 10GHz at 13dBm which is internally multiplied for the upconversion. The output signal is transmitted over 4m wireless distance using a single-feed LWA to multiple users. A user unit consists of a horn antenna with 22dBi gain. The received signal is amplified by a 35dB gain, 60GHz-band amplifier and is downconverted using an integrated receiver (Gotmic gRSC0016). The IF signal is amplified and captured using a Digital Oscilloscope (Tektronix, DPO72304DX) for offline processing. The offline processing in MATLAB includes carrier synchronization and QAM demodulation for EVM analysis.

The LWA transmits mmW frequencies higher than 60GHz towards the right-hand region of its broadside and vice versa [23]. The AWG (Tektronix 70001A) has only one output channel port from which only RF data can be generated (and not IQ). The integrated transmitter produces a double sideband by upconverting the composite SCM signal, as explained in our previous work [24], and thus a mirror image of the sideband (with frequencies lower than 60GHz). The unfiltered set of user-signals in the lower sideband (as neither a mmW bandpass filter nor single-sideband mixer was available) will be transmitted in the left-hand region of the LWA and upper sideband in the right-hand region, respectively. Only transmission and performance analysis of the upper-sidebands has been presented in this work for simplicity. In real systems,



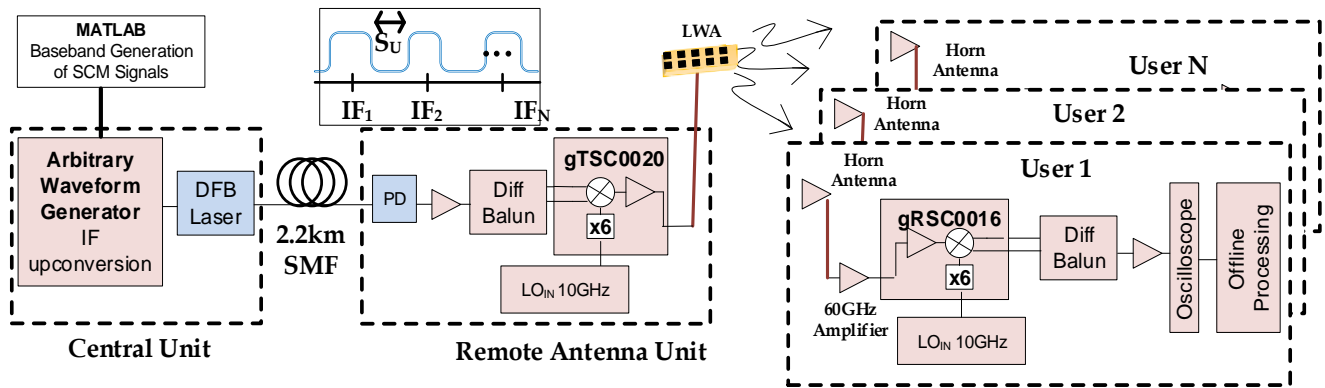

Fig. 4. Experimental Setup using single RF chain for Multi-user Transmission in 60GHz-band

upconverted mmW signals will be generated as a lower the undesired lower sideband can be removed and the left hand region of the LWA can serve another set of users.

The response of the AWG rolls off with frequency and the DFB laser (EMCORE 1933F) has an operational bandwidth of 4.5GHz. These limitations affect the performance of users as the IF is increased. Also, as the AWG provides a maximum -2dBm output power, this limits the maximum number of user signals in the generated SCM signal. The limitations of the setup affect the performance of users with high IF, which will be explained in the following sections.

### C. Demonstration of Multi-user Transmission

The EVM results after simultaneous transmission to three users, each with 1.06 Gb/s data rate (16-QAM, 305 MHz bandwidth for each user) after wireless transmission of 4m, is shown in Fig. 5. A sum data rate of 3.2 Gb/s (1.06Gb/s per user) is achieved in this case. All users obtain lowest EVM at the angle where their respective center frequency provides highest gain for the beam. The main limitation in the signal performance is the noise from the AWG, RF amplifiers and oscilloscope. Other sources of EVM degradation include errors in channel estimation and alignment of transmit/receive antennas. Higher QAM levels could be used if high SNR was available from the signal generator. The user with lowest IF has better performance than the others due to the bandwidth limitations of the AWG and RoF link. Larger numbers of users can be served simultaneously by adding subcarriers to the composite SCM signal, but how many depends on the spacing (guard band) between SCM signals, which will be discussed in the next section. A scenario where multiple users may be present at the same angular location through the transmission of different subcarriers towards them will be discussed in Section V.

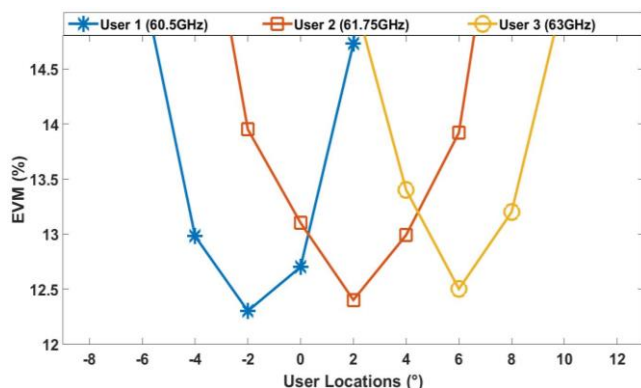

Fig. 5. EVM results for three users at different locations (1.06Gb/s per user is achieved using 16-QAM with symbol rate of 265.8MSymbols/s)

### III. TRANSMISSION TO LARGE NUMBER OF USERS

Transmission to a large number of users can be achieved within a specific transmission bandwidth by using smaller user-signal spacings. To analyze the effect of user-signal frequency spacing for the multi-user transmission, a composite SCM signal was generated for seven users, with same experimental parameters as used previously. The performance of all seven users (A to G) for different signal spacings (guard band) is evaluated. Only results for the 20x1 LWA are shown in this section for simplicity, as it will always perform better than the 12x1 LWA due to the additional 2dB gain per beam. The EVM results for the seven users are shown in Fig. 6. As the user-signal spacing increases, the center IF for each signal increases, resulting in performance degradation due to the bandwidth limitations of the components. Only three values of signal spacings have been used during the experiments for simplicity. The 50 MHz spacing provides lowest EVM overall, because the composite signal occupies a reduced frequency span; this spacing is used in the next set of experiments to determine the largest number of users that can use a single RF chain. Spacings smaller than 50MHz weren't used during the experiments because AWG limitations causes non-zero out-of-band suppressions for the generated signal. For EVM performance at the receiver as shown in Fig. 6, it can be seen that the EVM degrades towards user G due to the increase in IF. Considering the limit of 15% for 16-QAM with conventional FEC [25], five user-signals have been able to meet the specification, with the others not conforming due to the roll off in the performance of AWG and RoF link.

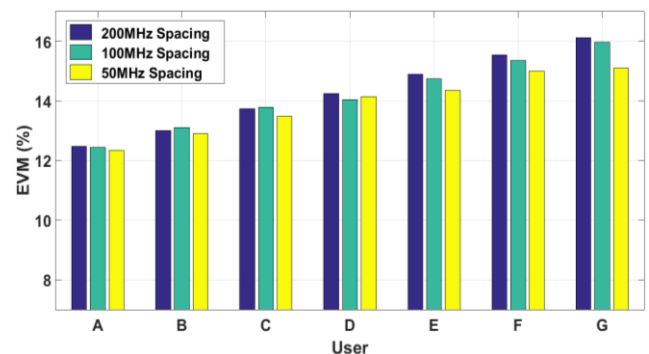

Fig. 6. EVM per user for end-to-end transmission for different user spacings using 20x1 LWA

The SNR of user signals generated from the AWG decreases with the increase in number of signals. For 16-QAM modulation, a limited number of user signals can be generated by the AWG with adequate SNR to meet the EVM requirement at the receiver. To ensure each user's EVM is

under the 15% limit, transmission to ten users can be performed by generating two sets of user-signals separately, each with five users, as shown in Fig 7.

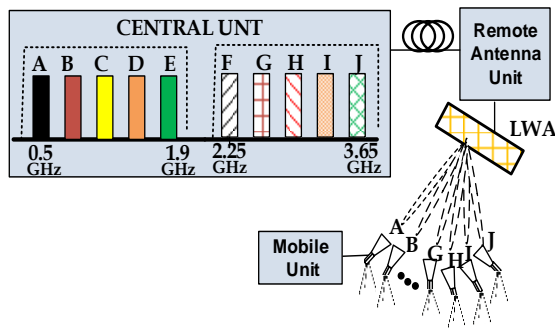

Fig. 7. Experimental Setup for Ten users Transmission using single LWA

Fig. 8 shows the performance of each user (A to J) where the first user is placed at an IF of 0.5 GHz (upconverted to 60.5 GHz) and last user at 3.65 GHz (upconverted to 63.65GHz). Again, performance degrades with the increase in IF due to the bandwidth limitations of the AWG and the RoF link, but, for this particular case, the EVM for ten users satisfies the 15% limit for 16-QAM, and a sum data rate of 10.6Gb/s is achieved. While, 16-QAM has been used in the experiments reported up to now, further increase in the number of users (using the same transmit power) will further reduce the SNR per user-signal. In that case, 4-QAM can be used, for which the receiver EVM requirement is 22% [26].

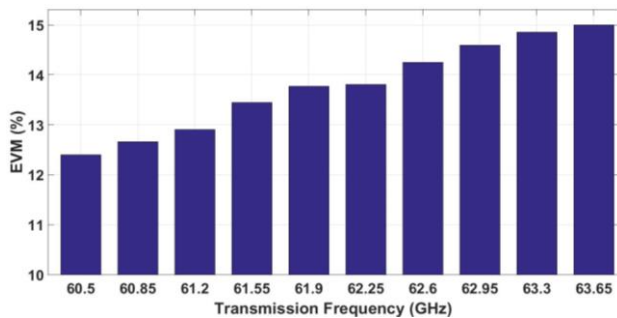

Fig. 8. EVM for Ten Users (A to J) with 305MHz (16-QAM) bandwidth per user and sum data rate of 10.6 Gb/s

Generation of an SCM signal for 10 users from the AWG 70001A provides sufficient SNR for each user-signal after the downlink transmission from CU to the user end to meet EVM requirements. Transmission to 20 users can be performed by serving two sets of 10 users, one at a time (as was done for the 16-QAM results in Fig.8). Fig. 9 shows the performance of 20 users with 4-QAM modulation. Ten users were transmitted in the first set (IF from 0.5 GHz to 3.65 GHz) and another ten users in the next (IF from 4.05 GHz to 7.15 GHz). The EVM for the 20<sup>th</sup> user after end-to-end transmission is 21.5%, still under the limit for 4-QAM. The sum data rate from the 20 users is 10.6Gb/s, but if the limitations of the AWG and RoF components are ignored, each user could attain similar performance to that of the first user with 13% EVM. In that case, with 16-QAM, a sum data rate of 21.2Gb/s could be achieved with 20 users, each with 305MHz bandwidth comprising a total transmission bandwidth of 6.1 GHz. The effective data rate of 1.06Gb/s using 305MHz user bandwidth provides a spectral efficiency of 3.47 bits/Hz which is lower than the 4 bits/Hz for 16-QAM due to the null subcarriers and cyclic prefix for each user signal. Much higher sum rate can be obtained using higher QAM levels, if higher SNR could be realized with the equipment. In addition

to available SNR, the sum rate also depends on the user-signal bandwidth because of the beamsteering characteristics of the LWA as shown by the frequency response in Fig. 3. This will be analyzed in the next section.

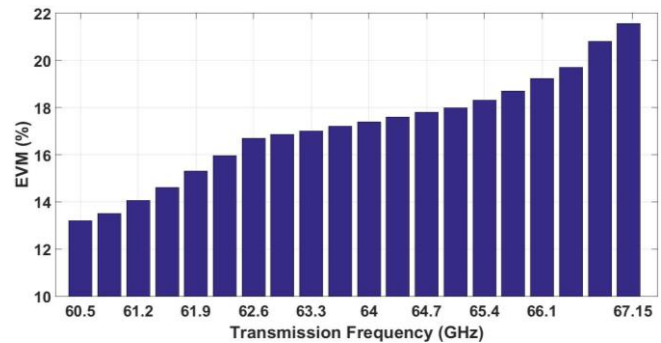

Fig. 9. EVM per user for twenty users (QPSK Modulation, 305 MHz bandwidth, 0.53 Gb/s per user)

#### IV. SNR DEGRADATION FOR LARGE BANDWIDTH SIGNAL AND THEORETICAL SUM RATE MAXIMIZATION

As the maximum gain of a beam corresponds to the specific frequency at the beam angle, the beam steering characteristics of the LWA will cause a power degradation at the edges for wideband signals. This effect is analyzed by evaluating the performance of individual subcarriers within a large bandwidth OFDM signal transmitted by the LWAs. Fig. 10 shows the received EVM after the transmission of a 4.88 GHz signal with 4-QAM modulation, centered at 63 GHz. The frequency dependent insertion loss and return loss of the V-band connectors and cables causes amplitude variations across the frequency response in the modulated signal [27], [28]. Variations in received signal were observed when interacting with the equipment and effort was made to apply appropriate connector torque, minimize the bending of cables and to keep the system stable during the measurements. Fig. 10 shows how the EVM fluctuations were smoothed out using a moving average filter in MATLAB, in order to observe a clearer trend for the EVM performance of the OFDM subcarriers and to perform further analysis for SNR to calculate a 3dB bandwidth. The fluctuations were smoothed using span (percentage number of input points to compute each element of output vector) of 20% (0.2) and 40% (0.4). The mean EVM for the two smoothed curves shows similar values.

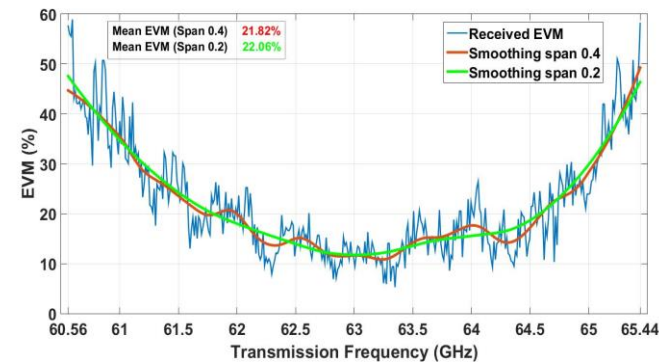

Fig.10. EVM per subcarrier from transmission of 4880 MHz OFDM signal before and after the application of smoothing function

Further analysis is performed by converting the EVM per subcarrier to SNR [29] for the 4.88 GHz bandwidth signal transmission for the two LWAs, as shown in Fig. 11. The EVM results obtained by using a smoothing span of 0.4 have

been considered here, as it provides less variations from the mean EVM as compared to 0.2. From Fig. 11, the 3dB bandwidth for the 20x1 LWA and 12x1 LWA are estimated as 1.92 GHz and 3.05 GHz respectively. The 20x1 LWA provides better performance for the middle subcarriers due to

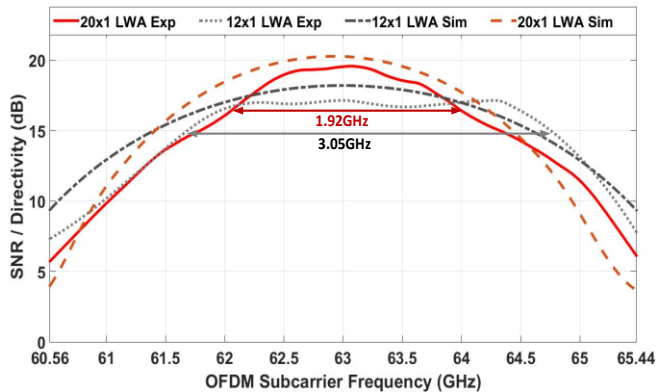

Fig. 11. SNR per subcarrier comparison of transmission of 4880 MHz OFDM signal (400 data subcarriers) for the two LWAs

having slightly higher gain. The SNR of subcarriers on the edges experience high degradation for both LWAs, but this degradation is sharper for the 20x1 LWA. The simulation results for 20x1 LWA and 12x1 LWA frequency response (as shown in Fig. 3) are also plotted over the span of 4.88GHz to show agreement with the experimental results. The analysis performed on the SNR degradation due to the LWA beam pattern shows that as user signals centered at different frequencies are directed in different directions, a wideband user-signal will experience lower beam gain at its edges. Specific signal bandwidths (such as 305MHz, 4880MHz) have been used during the experiments, corresponding to a defined set of discrete baseband sampling rates supported by the oscilloscope.

To analyze the effect of LWA beamsteering on sum rate for a particular transmission bandwidth, the theoretical sum rate for different numbers of users can be calculated. For a fixed overall transmit power, the allocated power of each user decreases with the increase in number of users. However, if the total transmission bandwidth is divided equally into smaller bandwidth signals, the power reduction is mitigated by the increased average channel gain (as the lower bandwidth signals experience less degradation at their band edges). Consider a total transmission bandwidth  $B_T$ , divided equally among  $N$  number of users. The user bandwidth is  $B_U$  and received user SNR is  $SNR_U$ . The sum rate  $R_S$  can be calculated by summing the rates  $R_U$  from all  $N$  users, given in terms of Shannon's equation

$$R_S = \sum_{U=1}^N R_U = \sum_{U=1}^N B_U \log_2(1 + SNR_U) \quad (1)$$

For a  $B_T$  of 6.1 GHz (as used in the experiments), divided equally among the users, and considering a receiver SNR of 15dB as the maximum user SNR (equivalent to the EVM achieved for the first user shown in Fig. 9), the degradation in SNR for various bandwidth signals can be calculated by using the simulation results for the 20x1 LWA gain pattern (shown in Fig. 3). The degradation in power for a specific frequency span causes a corresponding decrease in SNR for a user-signal  $SNR_U$  (for bandwidth  $B_U$  which is  $B_T/N$ ) [30], [31]. Using (1) and the calculated  $SNR_U$  that a user will have with bandwidth  $B_U$ , the sum rate for different numbers of

users can be plotted, as in Fig. 12. It can be seen that the sum data rate increases with the number of users, when the total transmit power is constant, approximately saturating when the user-signal bandwidth is small enough, 0.87GHz in the case of seven users, to cause insignificant SNR degradation due to the LWA beamsteering effect. The sum rate then saturates at 30.67 Gb/s (spectral efficiency of 5bits/Hz). The sum rate has also been plotted in Fig. 12 for the situation where 3dB additional SNR is available from the user-signal generator, providing a maximum sum rate of 36.6 Gb/s

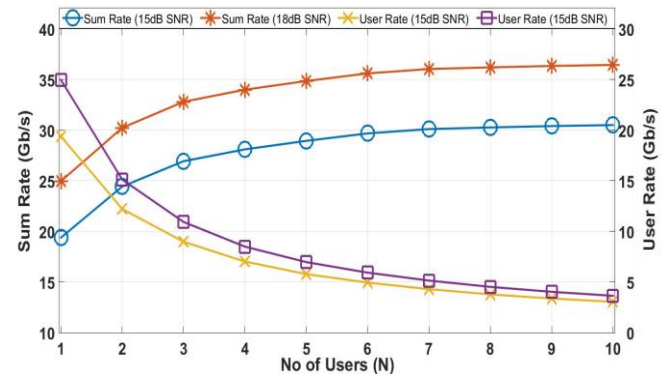

Fig. 12. Theoretical Maximum sum rate for different number of users

(spectral efficiency of 6bits/Hz). Overall, the effect of LWA beamsteering on high bandwidth signals is observed, with maximum sum rate obtained when the user bandwidth is small enough to not to be affected by the LWA. It can be seen that, even for the 20x1 LWA which has a narrower bandwidth, the saturation occurs at a number of users where each is still able to obtain reasonable multi-Gb/s data rates.

## V. IMPROVEMENT IN COVERAGE WITH MULTIPLE LWAS

High permittivity laminates can enable large steering angle for the LWA, hence enabling better coverage at the cost of degradation in radiation efficiency [32]. While localization is required to track mobile users, which is out of the scope of this article, the presented LWAs have been applied for simultaneous localization of multiple users [33]. Thereby, a high spatial and angle accuracy has been demonstrated. The simple beam steering mechanism of the LWAs in principle allows for centralized steering and user tracking at the central unit via the modulated IF. As only a particular carrier frequency is transmitted at a specific angular direction in the presented setup, this may lead to an inefficient usage of spectrum, as there might be no users at certain directions. Another design consideration is to increase the availability of the network for particular angular locations (while using single RF chain) by operating multiple LWAs in parallel. For a LWA transmitting different frequency signals towards particular angular locations, a parallel operating LWA in inverted position will provide a different set of frequencies for the same user angle using overlapping beams. Due to the unavailability of a 60 GHz-band power splitter, to demonstrate the feasibility of this approach, the experiment is performed using two LWAs in series as shown in Fig. 13. Two user signals centered at IFs of 0.5 GHz and 4 GHz, upconverted to 59 GHz and 62.5 GHz (each having 305 MHz bandwidth), are provided to the pair of LWAs.

The 12x1 LWA provides transmission to two different angles for the two user signals. The composite signal then travels through to the 20x1 LWA, which is used in inverted



orientation to provide the transmission of the same two signals at the opposite angular directions. Due to the reduced power, transmission from the second LWA was achieved for 0.5m wireless distance, which could be improved with amplification. After adjusting the tilt of the second LWA, the corresponding angles of the 62.5GHz and 59GHz beam were made similar to the 59GHz and 62.5GHz beams of the first LWA, respectively, and data was captured using the two user locations in the left-hand and right-hand regions of the transmission. The EVM for 59GHz and 62.5GHz centered signals after 4m of wireless transmission from the 12x1 LWA was found to be 12.02% and 12.5%. The EVM performance after 0.5m transmission from the 20x1 LWA was 13.5% for the 62.5GHz and 13.3% for the 59GHz user-signals, and within experimental inaccuracy, the corresponding angles were the same. This demonstrates a simple method for reusing frequency spectrum, when utilizing highly directive antennas, without adding significant system complexity. Use of multiple LWAs will improve the coverage and spectral efficiency, through increased flexibility in allocating frequencies to users, independent of their location, but will result in a decrease of the transmit power, and hence transmission distance. Additional amplification can be used to mitigate against this. (As there would be no added upconversion/filtering etc., this would not result in full extra RF chains, so still enabling a substantial part of the sought-after RAU simplification).

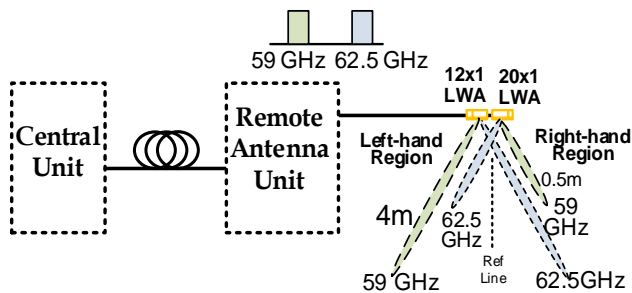

Fig. 13. Experimental Setup for Cascade design of LWA Transmission (the user angles and transmission distances are not to scale)

In this work, transmission to a single cell only has been presented. For multiple cells, Wavelength Division Multiplexing (WDM) can be used to address the different RAUs [34]. RAUs might operate for separate base stations, in which case the usual mobile system handover procedures would apply. They could also operate as part of the same base station, and, here, cooperative (joint) transmission and reception techniques for distributed MIMO [35] can be applied. Such an application would be particularly useful in dense user environments to be served by multiple RAUs delivering high-speed data (e.g. high-definition video, virtual reality) to many users.

## VI. CONCLUSION

A low-cost, low complexity 60 GHz-band multi-user transmission system based on SCM-RoF transport and the beamsteering property of a LWA is presented, using a single RoF link and single RF chain. Experimental analysis for characterization of the system is performed, serving 20 spatially distributed users and achieving a sum data rate of 10.6 Gb/s. Investigation on SNR degradation of large bandwidth signals due to LWA beamsteering shows that the sum rate from multi-user transmission increases with the number of served users, for a fixed transmission bandwidth,

but saturates when the user-signal bandwidth is small enough to be unaffected by the LWA. The spectrum efficiency is improved using multiple LWA operation by performing the transmission of different frequencies to similar angular directions.

## ACKNOWLEDGMENT

This work has been supported by the European Union's Horizon 2020 Research and Innovation programme under contract 643297 (RAPID). The authors are grateful to Omer Sheikh and Joe Langston at Tektronix for the loan of the AWG 70001A for the measurements on the wideband signals. The authors are also thankful to Prof. Stuart Walker of the University of Essex, UK, and Dr. Terence Quinlan for providing the integrated transmitter and receiver circuit boards.

## REFERENCES

- [1] P. Cao and J.S. Thompson, "Practical multi-user transmission design in millimeter wave cellular networks: Is the joint SDMA-TDMA technique the answer?", *IEEE 17th Intl Workshop on Signal Process. Advances in Wireless Commun. (SPAWC)*, 2016, pp.1-5.
- [2] J. Wang, H. Zhu, N.J.Gomes and J. Wang, "Frequency Reuse of Beam Allocation for Multiuser Massive MIMO Systems", *IEEE Trans. Wireless Commun.*, Vol. 17(4), 2018, pp. 2346-2359.
- [3] F. Sohrabi and W. Yu "Hybrid digital and analog beamforming design for large-scale antenna arrays", *IEEE J. Sel. Topics Signal Process.*, Vol. 10(3), 2016, pp.501-513.
- [4] IEEE, "IEEE 5G and Beyond Roadmap" *White Paper*, October 2017.
- [5] N.J. Gomes, M. Morant, A. Alphones, B. Cabon, J.E. Mitchell, C. Lethien, M. Csörnyei, A. Stöhr and S. Iezekiel, "Radio-over-fiber transport for the support of wireless broadband services", *J. Opt. Netw.*, Vol. 8(2), 2009, pp.156-178.
- [6] C. Liu, L. Zhang, M. Zhu, J. Wang, L. Cheng and G.K. Chang, "A novel multi-service small-cell cloud radio access network for mobile backhaul and computing based on radio-over-fiber technologies", *J. Lightw. Technol.*, Vol. 31(17), 2013, pp.2869-2875.
- [7] A.E. Aighobahi and N.J. Gomes, "Capacity and Error Performance Verification of Multi-Antenna Schemes in Radio-Over-Fiber Distributed Antenna System", *J. Lightw. Technol.*, Vol. 34(20), 2016, pp.4779-4785.
- [8] Y. Yang, M.J. Crisp, R.V. Penty and I.H. White, "Low-cost MIMO radio over fiber system for multiservice DAS using double sideband frequency translation", *J. Lightw. Technol.*, Vol. 34(16), 2016, pp.3818-3824.
- [9] G.K. Chang, C. Liu, and L. Zhang, "Architecture and applications of a versatile small-cell, multi-service cloud radio access network using radio-over-fiber technologies", *IEEE Int Conf. on Commun Workshops (ICC)*, Budapest, Hungary, 2013, pp. 879-883.
- [10] W. Zhou, M. Stead, S. Weiss, O. Okusaga, L. Jiang, S. Anderson and R.Z. Huang, "Developing an integrated photonic system with a simple beamforming architecture for phased-array antennas", *Appl. Opt.*, Vol. 56(3), 2017, pp.5-13.
- [11] Y. Chai and F.S. Choa, "Effects of optical filter drifts in wavelength division multiplexing system with cascaded optical amplifiers." *Vertical-Cavity Lasers, Digest of the IEEE/LEOS Summer Topical Meeting*, Canada, 1997, pp.36-37.
- [12] S. Pan and J. Yao, "Simultaneous provision of UWB and wired services in a WDM-PON network using a centralized light source", *IEEE Photonics Journal*, Vol.2 (5), 2010, pp.712-718.
- [13] E.J. Tyler, P. Kourtessis, M. Webster, E. Rochart, T. Quinlan, S. E. M. Dudley, S. D. Walker, R. V. Penty, and I. H. White. "Toward terabit-per-second capacities over multimode fiber links using SCM/WDM techniques" *J. Lightw. Technol.*, Vol. 21(12), 2003, pp. 3237-3243.
- [14] Kim, K., Lee, J., and J. Jeong, "Performance limitations of subcarrier multiplexed WDM signal transmissions using QAM modulation", *J. Lightw. Technol.*, Vol. 27(18), 2009, pp.4105-4111.
- [15] Y. Pei, K. Xu, J. Li, A. Zhang, Y. Dai, Y. Ji and J. Lin, "Complexity-reduced digital predistortion for subcarrier multiplexed radio over fiber systems transmitting sparse multi-band RF signals", *Opt. Express*, Vol. 21(3), 2013, pp.3708-3714.
- [16] S. Xiao and A. M. Weiner, "Four-user-3-GHz-spaced subcarrier multiplexing (SCM) using optical direct-detection via hyperfine WDM", *IEEE Photon. Technol. Lett.*, Vol. 17(10), 2005, pp.2218-2220.

- [17] J.M. Buset, Z.A. El-Sahn and D.V. Plant, "Experimental demonstration of a 10 Gb/s RSOA-based 16-QAM subcarrier multiplexed WDM PON", *Opt. Express*, Vol. 22(1), 2014, pp.1-8.
- [18] J. Morosi, J. Hoxha, P. Martelli, P. Parolari, G. Cincotti, S. Shimizu and P. Boffi, "25 Gbit/s per user coherent all-optical ofdm for Tbit/s-capable PONs", *J. Opt. Commun. Netw.*, Vol. 8(4), 2016, pp. 190-195.
- [19] L. Giorgi, F. Cavaliere, P. Ghiggino, F. Ponzini, A. Bianchi and A. D'Errico, "Characterization of a high capacity multi-user optical access network using 1 Gb/s 16 QAM subcarrier multiplexing", *J. Lightw. Technol.*, Vol. 27(9), 2009, pp.1203-1211.
- [20] M. Steeg, N. Yonemoto, J. Tebart, A. Stöhr, "Substrate-Integrated Waveguide PCB Leaky-Wave Antenna Design Providing Multiple Steerable Beams in the V-Band", *MDPI Electron.*, Vol. 6(4), 2017.
- [21] C. Sierens, D. Mestdagh, G.V.D. Plas, J. Vandewege, G. Depovere and P. Debie, "Subcarrier Multiple Access for Passive Optical Networks and Comparison to Other Multiple Access Techniques", *IEEE GLOBECOM*, Arizona, 1991, pp.619-623.
- [22] Y. Niu, Y. Li, D. Jin, L. Su and A.V. Vasilakos, "A Survey of Millimeter Wave (mmWave) Communications for 5G: Opportunities and Challenges", *Wireless Netw.*, Vol. 21(8), 2015, pp 2657-2676.
- [23] M. Steeg, B. Khani, V. Rymanov and A. Stöhr, "Novel 50-70 GHz compact PCB leaky-wave antenna with high broadside efficiency and low return loss", *IEEE 41st Int Conf. on Infrared, Millimeter, and Terahertz waves (IRMMW-THz)*, Copenhagen, Denmark, 2016, pp.1-2.
- [24] U. Habib, M. Steeg, A. Stöhr and N.J.Gomes, "Radio-over-Fiber-supported 60GHz Multiuser Transmission using Leaky Wave Antenna", *IEEE Int Topical Meeting on Microw. Photon. (MWP)*, Beijing, China, 2017, pp. 1-4.
- [25] H.M. Oubei, J.R. Duran, B. Janjua, H-Y. Wang, C-T. Tsai, Y-C.Chi, T.K.Ng, H-C. Kuo, J-H. H, M.S. Alouini, G-R. Lin and B.S.Ooi, "4.8 Gbit/s 16-QAM-OFDM transmission based on compact 450-nm laser for underwater wireless optical communication" *Opt. Express*, Vol. 23 (18), 2015, pp. 23302-23309.
- [26] A. Nkansah, A. Das, N. J. Gomes and P. Shen, "Multilevel modulated signal transmission over serial single-mode and multimode fiber links using vertical-cavity surface-emitting lasers for millimeter-wave wireless communications", *IEEE Trans. Microw. Theory Techn.*Vol. 55(6), 2007, pp.1219-1228.
- [27] Agilent Technologies, "8 Hints for Better Millimeter-Wave Spectrum Measurements", Application note 1391, 2002.
- [28] Keysight Technologies, "Microwave and Millimeter Signal Measurements - Tools and Best Practices", Application note, 2017.
- [29] R.A. Shafik, M.S. Rahman and A.R. Islam, "On the extended relationships among EVM, BER and SNR as performance metrics" *4th IEEE Int. Conf on Electr. and Comput. Eng. (ICECE'06)*, Bangladesh, 2006, pp.408-411.
- [30] C. Rauscher, v. Janssen and R. Minihold, "FREQUENT MEASUREMENTS AND ENHANCED FUNCTIONALITY" in *Fundamentals of spectrum analysis*, Rohde & Schwarz Germany, 2007.
- [31] R. Hranac and B. Currivan, "Digital transmission: Carrier-to-noise ratio, signal-to-noise ratio, and modulation error ratio." Broadcom Corporation and Cisco Systems, white paper, 2012.
- [32] K. Neophytou, S. Iezekiel, M. Steeg and A. Stöhr, "Design of PCB Leaky-Wave Antennas for Wide Angle Beam Steering", *11th German Microw Conf (GeMiC)*, Germany, 2018, pp. 152-155.
- [33] M. Steeg, A. Al Assad and A. Stöhr, "All Photonic Radar System based on Laser Frequency Sweeping and Leaky-Wave Antennas", *IEEE Int Topical Meeting on Microw Photon (MWP)*, France, 2018, pp. 1-4.
- [34] J.J.V. Olmos, T. Kuri and K.I. Kitayama, "Dynamic reconfigurable WDM 60-GHz millimeter-waveband radio-over-fiber access network: architectural considerations and experiment", *J. Lightw. Technol.*, Vol. 25(11), 2007, pp.3374-3380.
- [35] U. Habib, A.E Aighobahi, T. Quinlan, S.D. Walker and N.J. Gomes, "Analog Radio-over-Fiber Supported Increased RAU Spacing for 60GHz Distributed MIMO employing Spatial Diversity and Multiplexing", *J. Lightw. Technol.*, Vol. 36(19), 2018, pp. 4354-4360.

**Usman Habib** received the B.Sc. in Electrical Engineering from University of Engineering and Technology (UET), Peshawar in 2009 and M.Sc from UET, Taxila in 2013. He is currently working towards the PhD degree in Electronic Engineering at the University of Kent, Canterbury, UK. His research interests include Radio-over-fibre, 60GHz MIMO/CoMP and Beamforming.

**Matthias Steeg** received his B.Sc. and M.Sc. degrees in electrical engineering and information technology from the University of Duisburg-Essen, Germany, in 2012 and 2015, respectively. After his studies with focus on micro- and optoelectronics he joined the Department of Optoelectronics, University of Duisburg-Essen in 2015 as a Research Scientist. He is currently working toward his Ph.D. degree under the supervision of Prof. Stöhr. His research interests include radio-over-fiber techniques, mm-wave and THz communications, 5G mobile networks and mm-wave beam steering antennas.

**Andreas Stöhr (SM'97)** received the Dipl.-Ing. and Dr.-Ing. degrees in electrical engineering from the Gerhard-Mercator-University, Germany, in 1991 and 1997, respectively. From 1987 to 1996 he was the CEO of MS Steuerungsanlagen GmbH in Germany. From 1996 to 2013, he was a Research Scientist at the University of Duisburg-Essen (UDE). During that period, in 1998 and 1999 he also joined the Communications Research Laboratory, Tokyo, Japan where he worked on 60 GHz wireless systems employing radio over fiber techniques. He also worked with France Telecom Orange Labs, Lannion, France, in 2009 and with Corning, Inc., in 2015. Since 2011, he is Professor and Head of the Optoelectronics Department, Center for Semiconductor Technology and Optoelectronics, UDE, Germany.

His current research interests include III/V integrated microwave photonic devices and RF photonic integration for millimeter-wave and THz communications including 5G, measurement systems as well as sensing applications. He has published more than 200 papers in refereed journals and conferences. He is a Senior Member of IEEE Photonics and MTT society, Committee Member and Chair of a number of international conferences and IEEE/OSA Guest Editor.

**Nathan J. Gomes (M'92-SM'06)** received the B.Sc. degree from the University of Sussex, Sussex, U.K., in 1984, and the Ph.D. degree from University College London, London, U.K., in 1988, both in electronic engineering.

From 1988 to 1989, he held a Royal Society European Exchange Fellowship with ENST, Paris, France. Since late 1989, he has been with the University of Kent, Canterbury, U.K., where he is currently Professor of Optical Fibre Communications. His current research interests include fiber-wireless access, and RoF systems and networks.

Professor Gomes was a TPC Co-chair for the MWP 2014 IEEE Topical Meeting in Sapporo and TPC Chair for IEEE International Conference on Communications, ICC 2015 in London.