



Kent Academic Repository

Nkansah, Anthony, Callaghan, Peter, Gomes, Nathan J., Batchelor, John C. and Wake, David (2008) *EVM and Throughput Performance Measurement of Simultaneous Transportation of GSM900, GSM1800, UMTS and WLAN over a VCSEL Based Multimode Fibre Link*. In: URSI General Assembly, Chicago, IL, USA. .

Downloaded from

<https://kar.kent.ac.uk/15853/> The University of Kent's Academic Repository KAR

The version of record is available from

This document version

UNSPECIFIED

DOI for this version

Licence for this version

UNSPECIFIED

Additional information

Versions of research works

Versions of Record

If this version is the version of record, it is the same as the published version available on the publisher's web site. Cite as the published version.

Author Accepted Manuscripts

If this document is identified as the Author Accepted Manuscript it is the version after peer review but before type setting, copy editing or publisher branding. Cite as Surname, Initial. (Year) 'Title of article'. To be published in *Title of Journal*, Volume and issue numbers [peer-reviewed accepted version]. Available at: DOI or URL (Accessed: date).

Enquiries

If you have questions about this document contact ResearchSupport@kent.ac.uk. Please include the URL of the record in KAR. If you believe that your, or a third party's rights have been compromised through this document please see our [Take Down policy](https://www.kent.ac.uk/guides/kar-the-kent-academic-repository#policies) (available from <https://www.kent.ac.uk/guides/kar-the-kent-academic-repository#policies>).

EVM and throughput performance measurement of simultaneous transportation of GSM900, GSM1800, UMTS and WLAN over a VCSEL based multimode fiber link.

Anthony Nkansah¹, Peter Callaghan², Nathan J. Gomes³, John Batchelor⁴ and David Wake⁵

¹Broadband and Wireless Communications Group, Department of Electronics, University of Kent, CT2 7NY, UK.
Email: A.k.a.nkansah@kent.ac.uk, ²P.callaghan-89@kent.ac.uk, ³N.J.Gomes@kent.ac.uk,
⁴J.C.Batchelor@kent.ac.uk, ⁵Dwake@msbx.net

Abstract

Performance measurements of four wireless systems (GSM900, GSM1800, UMTS and WLAN) simultaneously transported over an indoor wireless network fed by a low-cost 850-nm vertical-cavity surface-emitting laser (VCSEL) – 300m length of multimode fibre is presented. The measurement focuses on the error vector magnitude (EVM) performance of the GSM900, GSM1800, and UMTS in co-existence with each other and with WLAN. Throughput performance of WLAN in co-existence with the other three wireless systems is also presented in this paper.

1. Introduction

It is now a necessity to improve the coverage and capacity for dense in-building user populations due to the volume of increasing portable wireless multimedia devices (mobile phones, laptops, etc) been used all over the world. For high data rate wireless applications such as UMTS and WLAN operating at carrier frequencies of 2GHz and above, the signal coverage is typically restricted to the building periphery when outdoor transceivers are used [1-2]. Radio over fiber based distributed antenna systems (DASs) are a cost-effective solution as they are easier to maintain with respect to placing multiple access points (APs) and base stations (BSs) throughout a building for improved coverage [1-2]. The DAS transports radio carriers from a central unit (CU) – where all the APs and BSs are housed - to a number of remote antenna units (RAUs). The centralisation of the APs and BSs allows for a better physical security and easier maintenance. Attractiveness about DAS is that it can be incorporated with multimode fibers (MMFs) as they are already installed in large buildings and continues to be installed in greater quantities than single-mode fibers due to their ease of handling [3].

Synergising these advantages, the addition of simultaneous transmission of multiple signals over in-building DAS improves its cost-effectiveness; for example to shared neutral host providers, providing shared infrastructure costs for different service providers. In this paper, error vector magnitude (EVM) is used to measure the performance of GSM₉₀₀, GSM₁₈₀₀, and UMTS in co-existence with each other and with WLAN. Additionally, this paper presents the throughput performance of WLAN in co-existence with the other three wireless systems.

2. Experimental Setup

The setup of the experiment is depicted in Figure 1. All the components of Figure 1 with an RF section had SMA connectors for easier connection at the expense of compactness. For the optical connections, ST connectors were used. The RF amplifiers implemented in Figure 1 were Mini-circuits ZX60-2522M with a frequency response of 0.5GHz – 2.5GHz. The four power combiners/dividers were manufactured by E-meca.com and they have a bandwidth of 3GHz. The experimental setup consists of three sections, a CU, 300m length of duplex OM3 MMF from Acome and an RAU. The downlink of the CU has four signal sources. Three Agilent vector signal generators (E4438C) were used to emulate GSM₉₀₀, GSM₁₈₀₀ and UMTS signals. A WLAN access point (AP) was used to generate the fourth signal. A four port power combiner gave the flexibility of combining any number and combination of the four signals together. The combined wireless signals were used to modulate the drive current of an inexpensive 850nm ULM receptacle multimode VCSEL (VCSEL₁) - the same type as used in [2]. The ULM VCSEL was biased at 10mA and has a bandwidth of 3GHz. A short length (20cm) of 50 μ m patch cord was connect to the VCSEL₁ and the slope efficiency was measured to be 0.25 W/A.

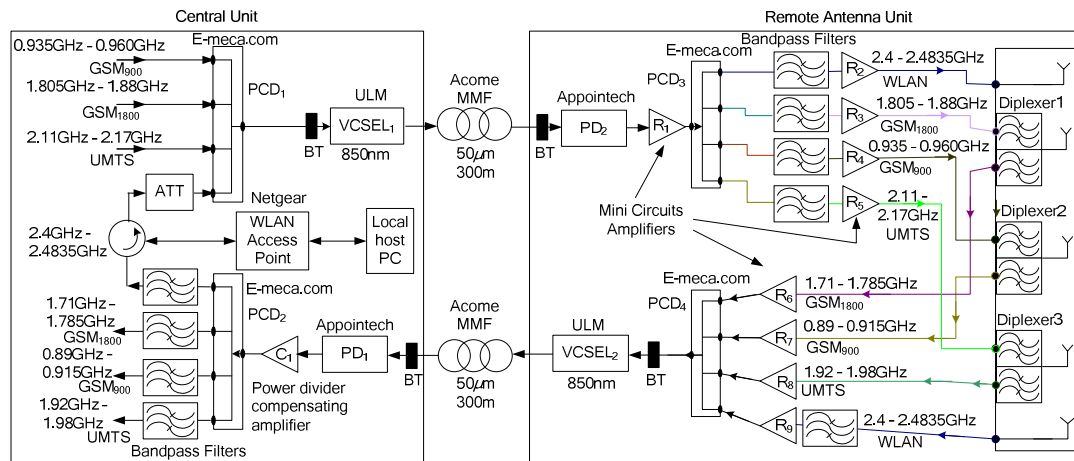

Figure 1 – Experimental setup of simultaneous transmission of GSM₉₀₀, GSM₁₈₀₀, UMTS and WLAN over an MMF link. PD=Photodiode, R₁ – R₈ = RAU amplifier, C₁ = CU amplifier, PCD= Power combiner/divider, ATT=Variable Attenuator, BT =Bias T

The bias Ts used in the experiments were Minicircuits ZFBT-6G with a bandwidth of 6GHz. A 300m length of Acome OM3 50 μm core twin zip MMF was then used to transport the modulated optical signal to the RAU. The optical signal was then collected by a receptacle Appointech GaAs PIN photodiode (PD₂) with a bandwidth of 1.5GHz and a responsivity of 0.61 A/W (measured). An amplifier (R₁) amplified the RF signal at the output of PD₂ to compensate for the power losses incurred from the optical path and power divider (PCD₃). Narrow band amplifiers were not available to us at the time of the experiments. However, the narrow band amplifiers were mimicked here by placing narrow band filters in front of the wideband amplifiers. Amplifiers R₂, R₃, R₄ and R₅ amplified the wireless signals WLAN, GSM1800, GSM900 and UMTS, respectively. The amplified signals were then, feed to their respective antennas as shown in Figure 1. Low profile antennas designed in [7] were used at the RAU for wireless transmission. Note that, all the diplexers were terminated with a 50 Ω load.

The EVM of the GSM₉₀₀, GSM₁₈₀₀, and UMTS in co-existence with each other and with WLAN transmitted through the downlink of Figure 1 were measured at the antenna port of the RAU.

2.1 Simultaneous WLAN full-duplex transmission with cellular systems

It has been demonstrated in [6] that it's possible to obtain good WLAN EVM measurement when transported simultaneously with three cellular systems (GSM900 at 0.9GHz, personal handy phone system at 1.9GHz and UMTS at 2.1GHz) over an 850nm VCSEL based 300m length of MMF link without wireless path. In this paper, throughput experiments were carried using the setup of Figure 1 including 2m length of wireless path. For downlink operations, all four wireless signals were transported to the RAU via the MMF optical link. At the RAU, only the WLAN was allowed to propagate wirelessly. For the uplink; all the amplifiers were active even though, amplifiers R₆ – R₈ had small leakage cellular signals from the downlink path to amplifier. The advantage of having discrete amplifier for each uplink signal is to allow the power level of the wireless signals to be set individually. Independent uplink power level settings for each wireless system are to ensure that the RAU VCSEL is not over driven at minimum distance conditions [2]. Minimum distance takes into account the worst case scenario when a mobile device is at a minimum distance away from the RAU while transmitting at full power to communicate with another access point or base station located outside the premises. Once, all the uplink signals are combined by PD₄, they are then transported to the CU via the uplink VCSEL MMF link. The amplified signal at C₁ is fed to a power divider (PD₂) – similar to PD₃. The WLAN signal is then filtered at one of the output port of PD₄ and transported to the WLAN AP for signal decoding.

3. Measurement Results

The standards of UMTS and GSM require the EVM to be 12.5% [8] and 7% [9], respectively. The measurements of the EVM results when all four wireless systems are transported simultaneously are depicted in

Figure 2, and Figure 3(a and b) for UMTS, GSM₉₀₀, and GSM₁₈₀₀, respectively. From the observation of Figure 2 and Figure 3b, the measured UMTS and GSM1800 EVM is well below the maximum values specified in [8] and [9] for the entire input power range at the CU VCSEL. The input power range at the CU VCSEL was from -30dBm to +5dBm, thus resulting in an EVM dynamic range of 35dB. For Figure 3a, the GSM₉₀₀ met its EVM specification at input powers of -25dBm to +5dBm. Note that the GSM₉₀₀ input power was set at 8dB below the other three wireless signal powers, and thus, the actual input power range of the GSM₉₀₀ was -33dBm to -3dBm. Hence, an EVM dynamic range of 30dB.

Similar EVM experiments have been carried out in [4-5]. In [4], the setup consisted of a high-linearity uncooled DFB laser in a pluggable module, 400m length of MMF, a PD and an electrical amplifier. The four signals transported over the optical link were GSM900, UMTS, WLAN and DCS (GSM1800). Input power range of the EVM measurement was not specified in [4]. However, the measured EVM values of all four wireless signals were below their respective standards. The system in [5] consisted of an electroabsorption modulator (EAM) external modulator at the CU, a 500m length of single mode fiber and a RAU. The RAU consisted of an optical amplifier, a PD and an electrical amplifier. Four wireless signals (UMTS, WLAN, GSM1800 and Personal Handypnone System) were transported over the optical link. Even though, the measurement input power ranged from -30dBm to 0dBm, only a range of -10dBm to 0dBm had EVM values below their respective standards. Hence, an EVM dynamic range of 10dB.

The WLAN throughput result is depicted Figure 4. Throughput as high as 20Mbps was observed for a wireless distance of 2m (with 300m optical link), indicating that the other three signals do not have a significant impact on the WLAN throughput performance.

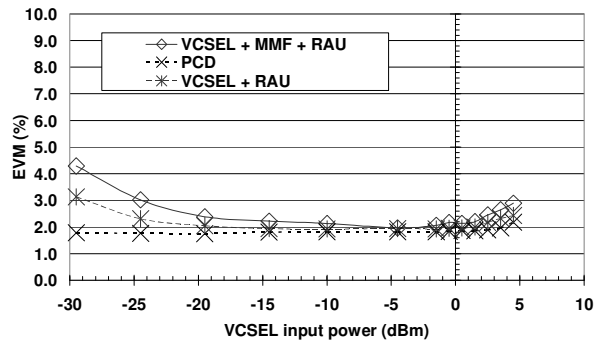

Figure 2 - Measured EVM of UMTS (with GSM₉₀₀, GSM₁₈₀₀, and WLAN present) at; input of CU VCSEL₁, and antenna port of diplexer 3 (with and without MMF) of Fig.1. Note that all signal sources were at equal power levels apart from GSM₉₀₀ at a power level of -8dBm below the others. PCD=Power divider combiner to VCSEL₁.

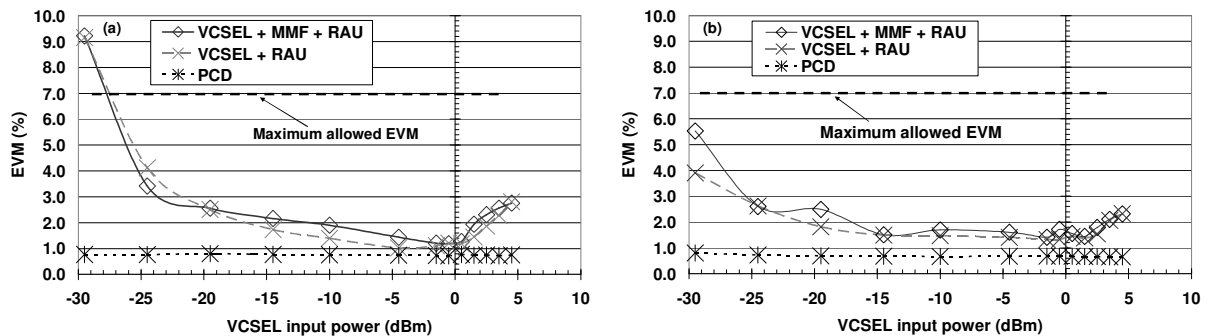

Figure 3 - Measured EVM of (a) GSM₉₀₀ and (b) GSM₁₈₀₀ (with UMTS, GSM₁₈₀₀, and WLAN present) at; input of VCSEL₁, and antenna port of diplexer 2 (with and without MMF) of Fig.1. Note that all signal sources were at equal power levels apart from GSM₉₀₀ at a power level of -8dBm below the others. PCD=Power divider combiner to VCSEL₁.

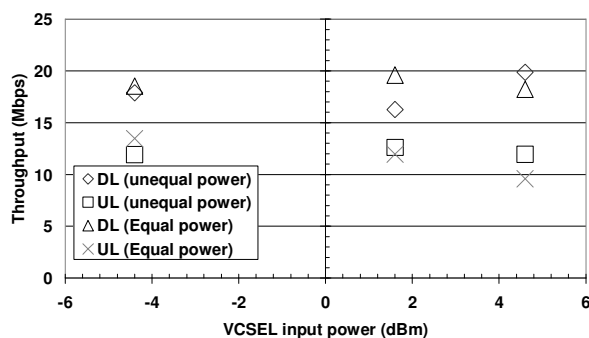

Figure 4 - Measured throughput of WLAN (with UMTS, GSM₁₈₀₀, and WLAN present) at a wireless distance of 2m. Note that “unequal power” means, all signal sources were at equal power levels apart from GSM₉₀₀ at a power level of -8dBm below the others. PCD=Power divider combiner to VCSEL₁.

4. Conclusion

It has been demonstrated that GSM900, GSM1800, UMTS and WLAN signals can be transmitted over an indoor wireless network fed by a low-cost multimode 850-nm VCSEL-MMF optical link with EVM (GSM900, GSM1800, UMTS) and throughput (WLAN) measurements within the required specifications.

5. Acknowledgments

The authors are grateful for the loan of two vector signal generators from Agilent Technologies (UK) arranged through the “ISIS” Network of Excellence. Mr. Philippos Assimakopoulos, Mr. Simon, Mr Robert Davis, Mr Clive Birch and Mr Terry Rockhill.

6. References

1. D.Wake, “Trends and prospects for radio over fibre picocells,” in *Proc. Int. Topical Mtg. Microw. Photon.*, Awaji, Japan, 2002, pp. 21–24.
2. A. Das, A. Nkansah, N. J. Gomes, I. J. Garcia, J. Batchelor, and D. Wake, “Design of low-cost multimode fiber fed indoor wireless networks,” *IEEE Trans. Microw. Theory Tech.*, vol. 54, no. 8, pp. 3426–3432, Aug. 2006
3. A. Flatman, “In-premises optical fibre installed base analysis to 2007,” presented at *the IEEE 802.3 10GBE Over FDDI-Grade Fibre Study Group*, Orlando, FL, Mar. 2004
4. P. Hartmann, X. Qian, R. V. Penty, I. H. White, “Broadband multimode fibre (MMF) based IEEE 802.11a/b/g WLAN distribution system,” in *Proc. Int. Topical Mtg. Microw. Photon.*, pp. 173-176, Maine, Oct. 2004.
5. P. K. Tang, L. C. Ong, A. Alphones, B. Luo and M. Fujise, “PER and EVM measurements of a radio-over-fiber network for cellular and WLAN system applications”, *J. Lightw. Technol.*, vol. 22, no. 11, pp. 2370-2376, Nov. 2004
6. M. L. Yee, H. L. Chung, P.K. Tang, L.C. Ong, B. Luo, M. T. Zhou, Z. Shao, M. Fujise, “850nm radio-over-fiber EVM measurements for IEEE 802.11g WLAN and Cellular signal distribution”, in *Proc. European Microw. Conference*, Manchester, UK, Sept. 2006, pp. 882 – 885.
7. P. Callaghan and J. C. Batchelor, “Multiband low-profile antenna for remote antenna unit pico cell applications”, submitted to *IEEE Trans. Antennas Propag.*
8. 3GPP TS 25.143 V6.2.0 (2004-09), “Technical Specification Group Radio Access Network; UTRA Repeater Conformance Testing,” Release 6.
9. 3GPP TS 11.21 V8.9.0 (2003-06), “Technical Specification Group GSM/EDGE Radio Access Network; Base Station System (BSS) Equipment Specification; Radio Aspects,” Release 1999.