



Kent Academic Repository

Nkansah, Anthony, Das, Anjali, Gomes, Nathan J. and Shen, Pengbo (2007)
Multilevel modulated signal transmission over serial single-mode and multimode fiber links using vertical-cavity surface-emitting lasers for millimeter-wave wireless communications. IEEE Transactions on Microwave Theory and Techniques, 55 (6). pp. 1219-1228. ISSN 0018-9480.

Downloaded from

<https://kar.kent.ac.uk/2665/> The University of Kent's Academic Repository KAR

The version of record is available from

<https://doi.org/10.1109/TMTT.2007.897728>

This document version

UNSPECIFIED

DOI for this version

Licence for this version

UNSPECIFIED

Additional information

Versions of research works

Versions of Record

If this version is the version of record, it is the same as the published version available on the publisher's web site. Cite as the published version.

Author Accepted Manuscripts

If this document is identified as the Author Accepted Manuscript it is the version after peer review but before type setting, copy editing or publisher branding. Cite as Surname, Initial. (Year) 'Title of article'. To be published in *Title of Journal*, Volume and issue numbers [peer-reviewed accepted version]. Available at: DOI or URL (Accessed: date).

Enquiries

If you have questions about this document contact ResearchSupport@kent.ac.uk. Please include the URL of the record in KAR. If you believe that your, or a third party's rights have been compromised through this document please see our [Take Down policy](https://www.kent.ac.uk/guides/kar-the-kent-academic-repository#policies) (available from <https://www.kent.ac.uk/guides/kar-the-kent-academic-repository#policies>).

Multilevel Modulated Signal Transmission over Serial Single-Mode and Multimode Fiber Links Using Vertical-Cavity Surface-Emitting Lasers for Millimeter-wave Wireless Communications

Anthony Nkansah, Anjali Das, Nathan J. Gomes, *Senior Member, IEEE*, and Pengbo Shen

Abstract— Quadrature phase-shift keying (QPSK), 16 quadrature amplitude modulation (QAM) and 64 QAM data transmission - Worldwide Interoperability for Microwave Access (WiMAX) modulation schemes - at 6 MSps and 20 MSps is demonstrated for a link that emulates a cost effective 1.55 μ m vertical-cavity surface-emitting laser (VCSEL) based radio over fiber millimeter-wave indoor pico-cellular system. The system consists of a concatenation of 20km single mode fiber and 300m multimode fiber links between a central office and remote antenna unit and employs remote 30GHz local oscillator (LO) delivery. Successful transmission over both optical and wireless paths is achieved with good error vector magnitude (EVM) performance recorded for both uplink and downlink. The performance is compared to other demonstrations of multilevel signal transmission in millimeter-wave over fiber systems.

Index Terms— Radio over fiber system, vertical-cavity surface-emitting laser, WiMAX, millimeter-wave communications, pico-cellular systems

I. INTRODUCTION

The increasing demand on current wireless consumer links has led to proposals for the use of millimeter-wave (mm-wave) frequencies for broadband wireless [1] - [3], and to topology proposals where a central office is connected to remote antenna units via optical fiber links [4] - [13]. At mm-wave frequencies, the high path loss and attenuation through man-made and natural objects favors the use of well-defined pico-cells. As a result, however, larger numbers of remote antenna units will be required for a given coverage area. For cost reduction reasons, there is then a requirement for the remote antenna unit to be of low complexity while a highly centralized central office is equipped with the more expensive (shared) optical and mm-wave components. The mm-wave generation techniques [12], transportation schemes [4] - [15] and architectural topologies [4], [5], [9], [10], [12], [13] of these systems will have a significant influence on the final cost of their deployment. A comparison of systems consisting

of star/tree and ring architectural topologies was performed in [4].

Various systems based on either single mode fiber [5] - [7], [11] - [13], [15] or multimode fiber [7], [8], [14] links have been proposed and experimentally demonstrated for mm-wave over fiber applications. Note that only [5], [10] and [11] conducted full-duplex experiments and the other systems concentrated on downlink transmissions, except for [9] where separate downlink and uplink experiments were carried out. Only [6], [10], [13] and [15] incorporated a wireless path in their experiments. These experiments will be reviewed in Section IV.

The aim of this work is to provide a fuller experimental verification of the system proposed in [9], including the wireless path. The experimental setup for the proposed system is described in Section II, whilst the results are presented in Section III. A performance comparison of the system presented here with previously reported experiments is presented in Section IV, and this is followed by conclusions in Section V.

II. EXPERIMENTAL SETUP

A. Proposed star-tree architecture

In the proposed star-tree architecture [9], the indoor picocells are generally located many kilometers from the central office. As shown in Fig. 1, the central office possesses multiple arms, where each arm is connected to a cluster. Each arm from the central office consists of a number of single mode fiber cable bundles, where each bundle is assigned to a premises. Each bundle is terminated at a fiber distribution unit (patch panel), from which individual single mode fibers service a "region". The single mode fibers are terminated at a remote antenna termination unit, from which multimode fibers service individual remote antenna units. The architecture has been described in detail in [9].

In this work, an attempt has been made to match the experimental setup as closely as possible to the architecture proposed in [9]. Note that the experimental setups for both uplink and downlink do not have complete central offices, remote antenna units, etc.; rather a number of components which provide the relevant sets of functions (but not all functions, and not for simultaneous uplink and downlink operation) were implemented in the experiments. The

Manuscript received November 20, 2006. The work was partially supported by the EU through the "ISIS" Network of Excellence.

A. Nkansah, A. Das, N. J. Gomes and P. Shen are with the Broadband and Wireless Communications Group, Department of Electronics, University of Kent, Canterbury, CT2 7NT, UK (e-mail: N.J.Gomes@kent.ac.uk, kagn2@kent.ac.uk).

experiments for both downlink and uplink have been carried out for a single remote antenna unit.

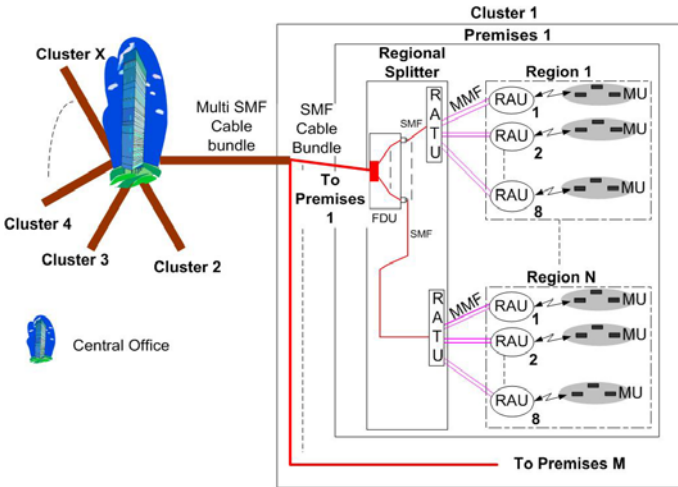

Fig. 1 - Topology of proposed mm-wave radio over fiber system from [9]. Mobile unit (MU), remote antenna unit (RAU), remote antenna termination unit (RATU), fiber distribution unit (FDU), single mode fiber (SMF), multimode fiber (MMF).

B. Downlink setup

The experimental setup for the downlink transmission including the wireless path is shown in Fig. 2. A vector signal generator was used to emulate the WiMAX modulation schemes at an IF of 1.14GHz.

The modulation formats specified in WiMAX 802.16c (10 - 66GHz) [2] consist of QPSK, 16-QAM and 64-QAM schemes. A Nyquist square-root raised cosine pulse shaping filter with a roll off factor of 0.22 is used in WiMAX for all modulation schemes. Note that there are only three symbol rates (16MSps, 20MSps and 22.4MSps) specified in the WiMAX 802.16c standards.

A prototype 1550nm single-mode VCSEL was used as the optical transmitter at the central office. The emulated WiMAX IF signals (QPSK, 16-QAM and 64 QAM) were used to modulate the VCSEL. The attenuator used after the VCSEL is used to represent the insertion loss of a wavelength multiplexer as proposed in [9], and further attenuation is incorporated into the link to emulate the losses from circulators proposed in [9]. To generate the optical mm-wave reference signal, the well-known frequency doubling technique using a Mach-Zehnder modulator biased at its null is employed [12], this producing an optical double side band suppressed carrier (DSB-SC) signal. An uncooled NEC DFB laser provides the optical signal to the Mach-Zehnder modulator. The optical mm-wave reference and the attenuated VCSEL signal were coupled together into a single mode fiber of length 20km using a 3dB coupler. The 20km single mode fiber was terminated by a regional splitter (which would be located at the destination premises) consisting only of the remote antenna termination unit function. The (low) insertion loss that would be caused by the fiber distribution unit was not included in the regional splitter.

The system proposed is cost-effective as the Mach-Zehnder modulator is shared by eight RAUs (as is the uncooled DFB

laser). As these components are located in the central office, stable operating temperatures are more readily achievable.

The remote antenna termination unit was made up of erbium-doped fiber amplifier (EDFA) and an eight port power splitter with an insertion loss of 10dB. A 300m length of multimode fiber (of $\geq 600\text{MHz}\cdot\text{km}$ bandwidth-distance product at 1300nm) was connected to one of the output ports of the power splitter via a single mode fiber patch cord using approximately center launch conditions. The multimode fiber terminates at the remote antenna unit where the optical signal was split using a two-way single mode power splitter, as a multimode power divider was unavailable to us.

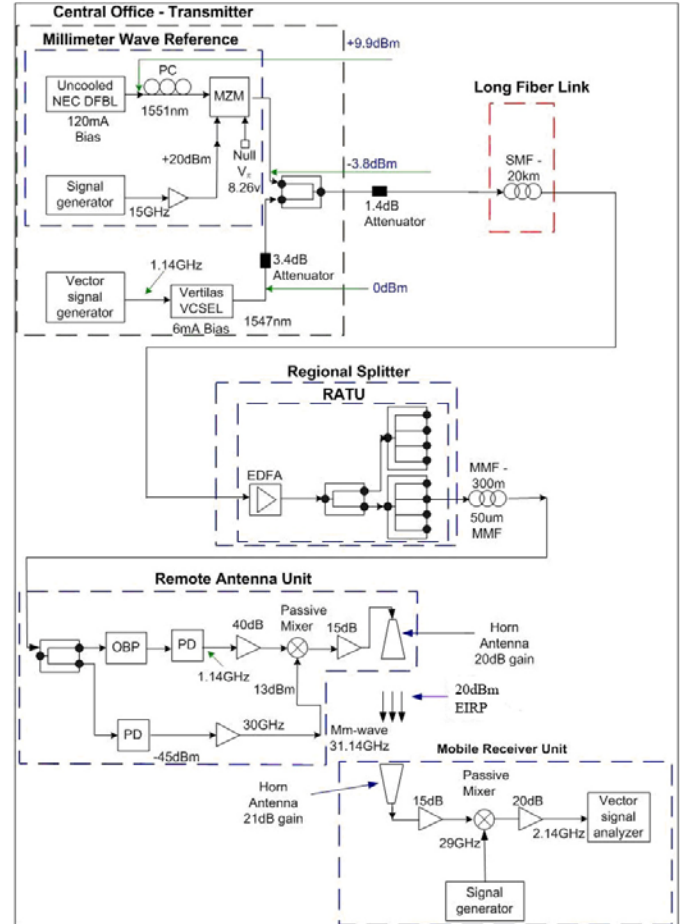

Fig. 2 - Downlink experimental setup including wireless path. Photodiode (PD), erbium-doped fiber amplifier (EDFA), Mach-Zehnder modulator (MZM), optical bandpass filter (OBP), single-mode fiber (SMF), multimode fiber (MMF), remote antenna termination unit (RATU), vertical-cavity surface-emitting laser (VCSEL), distributed feedback laser (DFBL), effective isotropic radiated power (EIRP)

For the IF data detection, a single mode tunable optical band-pass filter was inserted between one of the outputs of the two-way power splitter and a 3GHz bandwidth, single mode fiber-pigtailed photodiode. The filter passband was set to select only the IF data wavelength. The detected IF signal was amplified and fed to a passive mm-wave mixer. For the mm-wave detection, a 45 GHz bandwidth, single mode fiber-pigtailed photodiode with a responsivity of 0.4A/W was used. Due to the lower responsivity of the mm-wave photodiode, more optical power was required than was for the IF

photodiode. Therefore, to avoid additional insertion loss, no optical filter was used. Although, this meant that the IF signal was also detected in the mm-wave photodiode, the IF was effectively filtered out by the following mm-wave amplifiers which had low frequency cutoffs at 20 GHz. It is suggested that the system proposed in [9] could also be modified to eliminate the optical filter prior to the mm-wave photodiode. The amplified output electrical signals were fed to the mixer. The 30GHz mm-wave signal acts as the LO for the mixer, which upconverts the IF signal to the mm-wave band at 31.14GHz.

The upconverted mm-wave signal is then amplified and fed to a 20dBi horn antenna for wireless transmission. The downlink effective isotropic radiated power (EIRP) was 20dBm. The mobile receiver consisted of a 21dBi in-house horn antenna, 15dB mm-wave amplifier, a passive mixer, mm-wave LO, 20dB IF amplifiers and a vector signal analyzer for EVM measurements, as shown in Fig. 2. Note that EVM is specified in the IEEE 802.16c standard as a valid performance measurement.

C. Uplink setup

The uplink experimental setup is shown in Fig.3. At the central office, a photodiode and amplifier receive the uplink optical signal. The mm-wave reference optical generation technique and the remote LO delivery to the remote antenna unit mm-wave photodiode is the same as for the downlink. However, an optical 3dB coupler was inserted at the remote antenna termination unit prior to the EDFA to enable the uplink signal to be transported over the same single mode fiber as the reference LO signal. In the original architecture, as described in [9], an optical circulator is used rather than a coupler due to lower insertion loss. Again, some component losses in the uplink architecture of [9] were not emulated as the prototype VCSEL at the remote antenna unit had low output power. A lack of enough suitable connectors resulted in about 9.5dB excess optical power loss in connecting the multimode fiber to the single mode fiber patch cord of the power splitter. To compensate for this loss, no 3dB coupler at the remote antenna unit prior to the mm-wave photodiode was used, as would be required in the system configuration of [9].

For the uplink wireless transmission, a mobile transmitter with the 21dB in-house horn antenna transmitted emulated WiMAX signals at 31.14GHz wirelessly to a remote antenna unit receiver using the 20dB horn antenna. At the remote antenna unit, a passive mixer (similar to the one used in the downlink) is used to down-convert the incoming uplink signal to IF, using the remotely delivered mm-wave LO. The resulting IF signal is amplified and is used to modulate the VCSEL. This modulated optical signal is then coupled via an optical filter into a separate uplink multimode fiber of length 300m (same specifications as the downlink multimode fiber) for transport to the regional splitter, as described in [9]. The optical filter is used to protect the VCSEL from the incoming downlink optical mm-wave signal, as shown in Fig.3, where a circulator would be used in the system proposal [9].

The signal exiting the uplink multimode fiber is coupled into a 20km single mode fiber via a 3dB coupler in the regional splitter and transported to the central office. The

20km single mode fiber link, thus, simultaneously transported both the uplink VCSEL signal and the optical mm-wave reference signal (in opposite directions). At the central office, the optical uplink signal is detected by a photodiode and amplified. The EVM of the amplified signal was measured using a vector signal analyzer, for different experimental wireless distances.

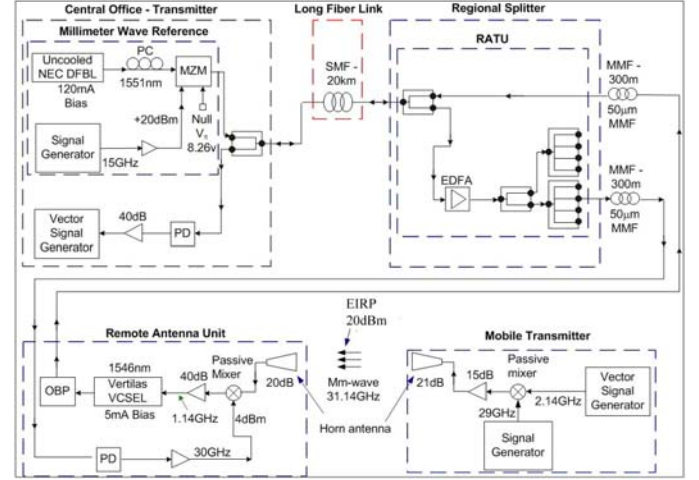

Fig. 3 - Uplink experimental setup including the wireless path. Photodiode (PD), erbium-doped fiber amplifier (EDFA), Mach-Zehnder modulator (MZM), bandpass filter (BP), single-mode fiber (SMF), multimode fiber (MMF), remote antenna termination unit (RATU), vertical-cavity surface-emitting laser (VCSEL), distributed feedback laser (DFBL), effective isotropic radiated power (EIRP)

III. MEASUREMENT RESULTS

A. Phase noise of mm-wave reference

The linewidth and phase noise of local oscillators in up- or down-conversion configurations can degrade data modulated signals. For this reason it is essential that the mm-wave over fiber link has little impact on the remotely delivered mm-wave LO reference [16], [17].

The frequency of the signal generator at the central office was set at 15GHz and its phase noise measured with a spectrum analyzer with external mixer (26.5 – 40GHz). At 10 kHz and 100 kHz offsets, the phase noise was measured to be -87dBc/Hz and -107dBc/Hz respectively. After optical generation of the mm-wave reference signal at 30GHz, the linewidth and phase noise were measured prior to and after transmission over the optical link (single mode fiber and multimode fiber). At the input to the optical link, the linewidth was measured as 600 Hz (using 300 Hz resolution bandwidth) and the phase noise was recorded as -80 dBc/Hz (10kHz offset) and -101 dBc/Hz (100 kHz offset). The phase noise is expected to increase as $20\log N$ (dB) for the N th harmonic. Hence, the phase noise increase is close to the theoretical 6 dB. The phase noise at the remote antenna unit was measured to be -80 dBc/Hz (10 kHz offset) and -101 dBc/Hz (100 kHz offset) and the linewidth also remained unchanged. Thus, the optical link has negligible impact on the linewidth and phase noise of the remotely delivered mm-wave signal.

B. WiMAX EVM requirements

The EVM requirements for a WiMAX base station transmitter and for a WiMAX receiver are shown in Table I and Table II, respectively [2]. The minimum symbol rate specified in the WiMAX 802.16c standards is 16MSps. However, the two EVM measuring systems used in this work supported maximum symbol rates of 6MSps and 20MSps respectively. So, the measurements have been carried out at these transmission rates only.

The different WiMAX modulation schemes (QPSK, 16 QAM and 64 QAM) were emulated using a vector signal generator at 1.14GHz for both 6MSps and 20MSps transmission rates. The quality of the signal from the vector signal generator, at both 6MSps and 20MSps, was checked using root mean square (rms) EVM measurements for different input power levels. The IF signal was then fed to a VCSEL connected to a photodiode by a short single mode fiber patchcord (back to back) and rms EVM and output power were recorded at the photodiode, again for different input power levels. This enables an investigation of the dynamic range and signal degradation in the back-to-back optical configuration for each modulation scheme.

TABLE I- EVM REQUIREMENTS FOR WiMAX BASE STATION TRANSMITTER

Modulation	EVM (%)	
	without equalization	with equalization
QPSK	12	10
16 QAM	6	3
64 QAM	3.1	1.5

TABLE II- EVM REQUIREMENTS FOR WiMAX RECEIVER

Modulation	EVM (%) / SNR (dB)
QPSK	32.36 / 9
16 QAM	10.78 / 16.8dB
64 QAM	4.64 / 23

Signal to noise ratio (SNR)

Note that all EVM measurements were conducted without using an equalizer. Each rms EVM reading was measured over 2500 symbols on both systems. For the 6MSps symbol rate, five sets of 100 rms EVM readings, with a 20 second interval between each set, were recorded using a macro program. The average and standard deviation was then calculated over the 500 rms EVM readings. For the 20MSps rate, only two sets of 20 rms EVM readings, with a 5 minute interval between the two sets, were recorded manually.

Fig. 4 shows the results for average rms EVM both at the output of the vector signal generator and after passing through the back-to-back configuration for the different modulation schemes at 20MSps.

The results show that the back-to-back configuration only meets the 64 QAM WiMAX transmitter requirements, shown in Table I, over the input power level range -15 to -5dBm. For 16 QAM, the input power has a threshold upper limit of -5dBm, below which it satisfies the WiMAX transmitter EVM of 6%, but no lower limit within the measured power range. The QPSK signal was within the WiMAX transmitter EVM specifications of 12% for all power levels even in the VCSEL saturation region, which can be seen from the plot of the IF

signal power measured at the photodiode. Multi-level modulation schemes are very sensitive to inter-modulation distortion. Thus, the modulation of the VCSEL in its nonlinear region with multi-level modulation schemes results in poor EVM as shown in Figs. 4 and 5. The best average rms EVM readings are obtained at input power levels between -12dBm and -7dBm for all modulation schemes.

The average rms EVM and power levels for the back-to-back configuration for the different modulation schemes at 6MSps are shown in Fig. 5. As with the 20MSps signals, the 6MSps signals experience poor EVM when driven into the VCSEL nonlinear region. However, all modulation schemes do meet their associated WiMAX transmitter EVM requirements when driven in the VCSEL linear region. QPSK allows drive signals well into the laser's saturation region while still meeting the EVM limit.

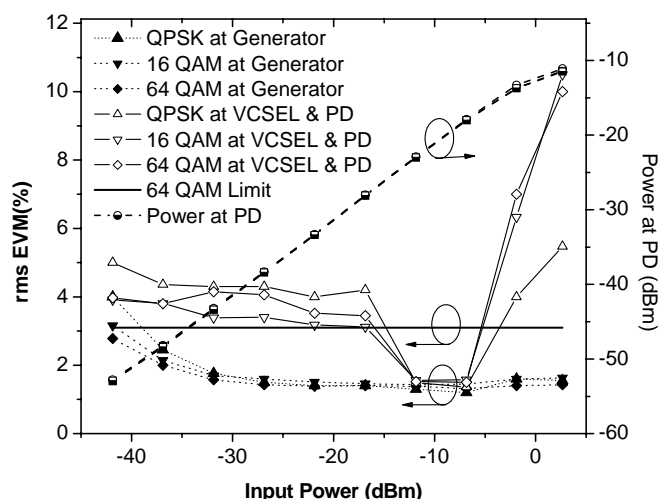

Fig. 4 – Average rms EVM and power measurement for WiMAX emulated schemes at 20MSps after the VCSEL and photodiode link (back to back) for different input power levels.

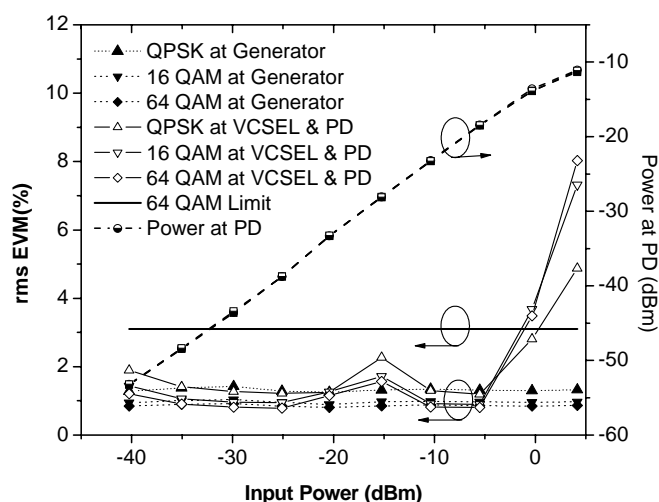

Fig. 5 – Average rms EVM and power measurement for WiMAX emulated schemes at 6MSps after the VCSEL and photodiode link (back to back) for different input power levels.

C. Downlink performance

The experimental results for the wireless downlink mm-wave over fiber transmission for the different modulation schemes at both 6MSps and 20MSps are shown in Fig. 6. The results show the average rms EVM measured for different wireless distances. The distance was limited to 4m due to the size of the measurement laboratory. Distance zero corresponds to the average EVM at the input of the remote antenna unit horn antenna (downlink transmitter). The power to the VCSEL at the central office was set to -12dBm for all modulation schemes. The EVM requirements for the WiMAX transmitter, as listed in Table I, set the upper limit for the downlink transmitted signal at the remote antenna unit. On the other hand, WiMAX receiver requirements, as stated in Table II, are used as the limit for the mobile receiver for the downlink and at the central office receiver for the uplink. Only the 64 QAM signal at 20MSps fails the very tight WiMAX requirements at the downlink transmitter (remote antenna unit). All the systems pass the receiver EVM specifications. Fig. 7 shows the constellation and eye diagrams for a 1m wireless downlink for the different modulation schemes. The clear and well defined constellation and eye diagrams are evidence of the achievement of successful transmission.

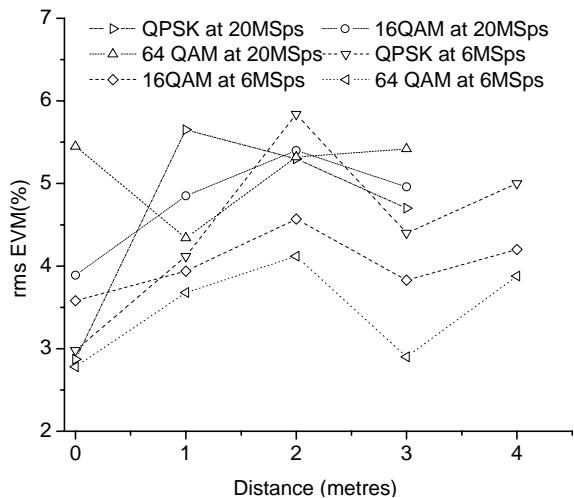

Fig. 6 – Downlink average rms EVM measurements of emulated WiMAX schemes for different wireless distances. The lines between symbols are only an aid for viewing the results and do not represent predicted trends.

D. Uplink performance

The results for the uplink signal transmission are shown in Fig. 8. At 20 MSps, 16 QAM signals meet the WiMAX receiver requirement up to a wireless range of 2m. The 20 MSps QPSK signal has an average EVM of 11.1% at the maximum measurement distance of 3 m. As the WiMAX receiver limit for QPSK modulation is 32%, a much greater wireless distance can clearly be achieved for the 20MSps QPSK signal. The 20 MSps 64 QAM signal, however, fails the WiMAX receiver requirements.

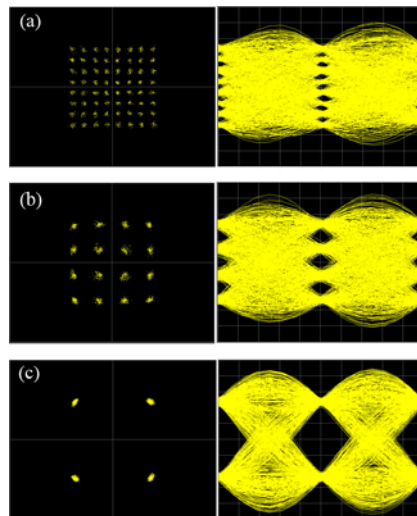

Fig. 7 – Constellation diagram and eye diagram of 1m wireless downlink for a) 20MSps 64 QAM data, b) 20MSps 16 QAM data c) 20MSps QPSK data

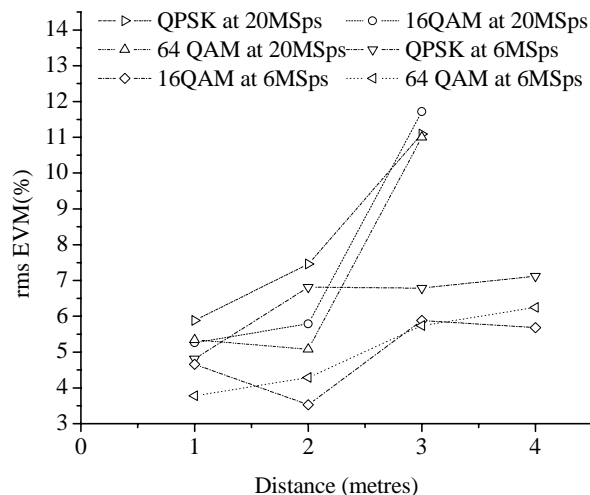

Fig. 8 – Uplink rms EVM measurements of emulated WiMAX schemes for different wireless distances. The lines between symbols are only an aid for viewing the results and do not represent predicted trends.

TABLE III – UPLINK EVM MEASUREMENTS OF EMULATED WIMAX FIBER-WIRELESS TRANSMISSION AT 6MSps (4 METERS)

Modulation	rms EVM (%) (without amplifier)	rms EVM (%) (with amplifier)
QPSK	7.2	3.9
16 QAM	5.7	2.9
64 QAM	6.3	2.8

With 6 MSps modulation, only the 64 QAM signal fails the WiMAX receiver limit, and only beyond 2m. To increase the wireless distance by compensating for some wireless path loss, a 15dB mm-wave amplifier was inserted after the remote antenna unit horn antenna of Fig.3. A comparison of the averaged rms EVM measurement results at 6 MSps for the two cases of with and without the 15dB mm-wave amplifier at the remote antenna unit for a wireless distance of 4 m is shown in Table III. The results show that the WiMAX receiver EVM requirement is met for all modulation schemes. At smaller distances, however, the 15dB additional amplification will cause the VCSEL to be driven into its

nonlinear region. As can be observed from Fig. 5, this will result in poor EVM for all modulation schemes except QPSK at 6 MSps. This dynamic range problem, in a real system, could be solved by the central office using dynamic power control techniques to reduce the transmit power of closer mobile units.

E. Discussion

The 20MSps/120Mbps 64 QAM uplink transmission did not meet the WiMAX requirements and the 20MSps/80Mbps 16 QAM uplink transmission only met the requirement for shorter wireless range. The inclusion of a mm-wave amplifier would enable longer distance transmission at the cost of making nearer mobile transmissions fail due to distortion from overdriving the VCSEL. However, this dynamic range problem is evident in the back-to-back measurements of Figs. 4 and 5; in Fig. 4, there is a sudden increase in EVM as the input power is reduced to -15 dBm, and in Fig. 5 there is a peak in the measured EVM at around -15 dBm. Separate measurements confirmed that these artefacts were particular to the IF photodiode unit being used (probably due to bias circuit resonances); they were not apparent when using the mm-wave photodiode to detect the IF signals. Thus, improved results should be obtainable with a different photodiode for the IF modulated signal detection.

For the complete mm-wave over fibre link, core mismatch occurs when the signal from the large core multimode fiber is coupled into single mode fiber or a photodiode with a small active area. In the case of coupling to single mode fiber, as only the fundamental mode from the multimode fiber is coupled, power penalties will occur. Due to the larger diameter of the signal beam exiting the multimode fiber, there will be a coupling loss (and modal noise) problem when using a photodiode with a small active area. When a core mismatch problem is combined with a link with a poor dynamic range, the performance of the overall link degrades dramatically as observed in the results for the 64 QAM modulation scheme. A more detailed discussion of the core mismatch problem, along with suggestions of components to mitigate this, has been provided in [9]. However, such components have been unavailable to us while conducting these experiments.

IV. PERFORMANCE COMPARISON OF PROPOSED SYSTEMS

In this Section, the results obtained are compared with those of other experiments, representing other system architectures. Mm-wave over fiber systems consist of three elements: the mm-wave generation scheme, the transportation scheme and the topology. We confine ourselves to comparisons between experiments using multilevel modulation schemes for which EVM results are available (or can be deduced), as shown in Table IV. Thus, the experiments reported in [10] and [11], which demonstrated successful transmission of high bit-rate data (up to 155 Mbps) over full-duplex single mode fiber links (including a wireless path in [10]) at around 37 GHz and 60 GHz, respectively, are not included as BPSK/DPSK modulation was used. In addition, the experiment of [12], in which simultaneous transmission of three downlink signals on separate wavelengths, and an uplink transmission, and with

single mode fiber and wireless paths included for both directions of transmission, is not included, as no EVM values are given; clear constellation diagrams are reported, as has been achieved in this work (see Fig. 7). Similarly, in [15], 100Mbps QPSK signals were transported over a single mode fiber link, upconverted to the 60GHz band at the remote antenna unit, and then transmitted to the mobile unit over a wireless distance of 4-12m; but, only eye diagrams and no EVM measurements were reported. Although none of the schemes compared are identical to that presented here, there are elements which are similar. Also, the aim for all is to transmit mm-wave signals to/from mobile units via remote antenna units and fiber, thus a comparison is useful.

Separate fibers were used for the full-duplex transportation of downlink and uplink signals in [13] in the emulation of a bus topology proposal. Three IF modulated optical signals, each at a different wavelength, were upconverted into the mm-wave band, by transmission through a Mach-Zehnder modulator driven by a microwave signal and biased at its null. The upconverted optical signal was transported to a remote antenna unit where a tunable optical filter could select any given wavelength. The electrical signal exiting the photodetector thus consisted of a mm-wave carrier and two sidebands. One of the sidebands was filtered and emitted to the mobile unit wirelessly at a distance of 5m, while the mm-wave carrier was used to downconvert the uplink signal to IF before transportation to the central office (in a similar manner to the uplink transportation of this work). Although, it was demonstrated that error correction coding can relax signal to noise ratio and EVM requirements for the same BER, the results most comparable with this work are those without the error correction coding, from which an EVM of around 17% can be inferred for uplink and downlink transmissions over both single mode fiber and 5m wireless paths.

For the experiments reported in [7] and [8], no topology was proposed, but the transportation schemes both involved mm-wave signal generation at the central office followed by delivery to the remote antenna unit. In [7] the transportation scheme for both downlink and uplink is the same as in [13] except that an optical frequency multiplication technique is used to generate the mm-wave signal. The frequency multiplication technique is based on harmonic generation using frequency modulation to intensity modulation conversion [7], in this case in a Mach-Zehnder interferometer located at the central office. Experimentally, a carrier at 3GHz and a 24Mbps 16 QAM signal at 200MHz were transported over different fibers to a remote antenna unit. At the output of the photodiode at the remote antenna unit, radio frequency components at every harmonic of the $3\text{GHz} \pm 200\text{MHz}$ signal are obtained. An IF filter selects the lower sideband of the 6th harmonic at 17.8GHz. The fibers used in the experiments were a 4.4km length of multimode fiber, and 12.5km and 25km lengths of single mode fiber; rms EVM recordings of 4.5%, 4.6% and 5.9%, respectively, were recorded. The values are slightly higher than the equivalent measurement in this work (3.6%), however, for the multimode fiber link, a longer length was used in [7] (4.4 km rather than 300 m). Thus, [7] suggests that it may be possible to use a longer length of multimode fiber for the system in this paper.

In [8], an electrical mm-wave LO at the central office is used to upconvert the IF signal before it is optically transported over the single mode fiber link. The signals transported were 10Mbps QPSK and 54Mbps 64 QAM orthogonal frequency division modulation (OFDM) at 20GHz, over different fibers: single mode fiber of length 2m (back-to-back), and multimode fiber of lengths 575m and 1km; the rms EVM results, taking into account bit rates, were of the same order as those recorded for the fiber link only in this work. As in [7], the results suggest it may be possible to use a longer multimode fiber length for the system here. It should be noted that for the systems of [7] and [8], in which multimode fiber was employed, no uplink or wireless transmissions were demonstrated.

The topology proposed in [5] is of a star-tree, with a ring at the end of each arm of the star-tree interconnecting several remote antenna units. The transportation scheme used is similar to that used here, where IF and mm-wave reference signals are delivered to the remote antenna units. In [5], experimental results were obtained for the “first” remote antenna unit in the ring of such a topology; thus, the downlink

distance corresponds to transmission over a 12.8 km star-tree arm only, whereas the uplink includes a 2.2 km ring (all single mode fiber). The rms EVM values obtained are well within requirements, but are higher than those reported here for a fiber link only. No wireless transmission was demonstrated in [5].

In [6], there was no particular proposed topology. Wireless transmission was carried out. The transportation scheme differs slightly from that used here as the mm-wave signal is electrically generated at the remote antenna unit. A 2.5GHz 16 QAM IF signal at 155Mbps was transported over a single mode fiber link of length 25km to a remote antenna unit. At the remote antenna unit, a mixer with an LO frequency of 57.2GHz was used to upconvert the IF signal to the mm-wave band at 59.7GHz. The upconverted signal was wirelessly emitted to a mobile unit at a distance of 2.6m. The rms EVM obtained at the mobile unit was between 4.7% - 8.4%. The results are largely consistent with the 16 QAM measurements presented in this work; our marginally lower rms EVM values having been achieved for lower data rate and carrier frequency.

TABLE IV – PERFORMANCE COMPARISON OF PROPOSED SYSTEM WITH OTHER MEASURED SYSTEMS

Data rate/ modulation/carrier frequency	Fiber link		EVM – fiber link only		Wireless distance	EVM – fiber link and wireless path	
	Uplink	Downlink	Uplink	Downlink		Uplink	Downlink
40 Mbps QPSK			N/A	2.9%		11.1%	4.7%
80 Mbps 16 QAM			N/A	3.9%		11.7%	5.0%
120 Mbps 64 QAM			N/A	5.5%		11.0%	5.4%
	20km SMF plus 300 m 50- μ m core MMF				3m		
12 Mbps QPSK			N/A	3.0%		3.9%	5.0%
24 Mbps 16 QAM			N/A	3.6%		2.9%	4.2%
36 Mbps 64 QAM			N/A	2.8%		2.8%	3.9%
31.14 GHz (this work)							
7 Mbps QPSK 37.6 GHz [5]	2.2km SMF plus 12.8km SMF	12.8km SMF	7.8%	10.5%	N/A		N/A
155 Mbps 16 QAM 59.7 GHz [6]		25km	N/A	N/A	2.6 m	N/A	4.7 – 8.4% (S/N:19 - 24dB)
10Mbps QPSK	2 m SMF			2.2%			
	575m 62.5- μ m core MMF			2.4%			
	1 km 50- μ m core MMF			2.8%			
54Mbps OFDM 64 QAM 20 GHz [8]	2 m SMF		N/A	3.8%	N/A		N/A
	575 m 62.5- μ m core MMF			4.2%			
	1 km 50- μ m core MMF			4.2%			
24 Mbps 16 QAM 17.8 GHz [7]	4.4km 50- μ m core MMF			4.5%			
	12.5 km SMF		N/A	4.6%	N/A		N/A
	25km SMF			5.9%			
50Mbps OFDM QPSK 59.869GHz for downlink and 59.822GHz for uplink [13]	12.8km SMF	21.3km SMF	N/A	N/A	5m	17.0% (15.4dB S/N)	17.2% (S/N: 15.3dB)
50Mbps QPSK	300m 50- μ m core MMF		N/A	N/A	5m	N/A	4.4%
100Mbps 16QAM 57.5GHz [14]							4.6%

Multimode fiber (MMF), single mode fiber (SMF), signal to noise ratio (S/N)

In [14] a similar transportation scheme to [6] was used, with an IF signal transported over the optical link and upconverted using an electrical LO located at the remote antenna unit. However, [14] included a multimode fiber rather than single mode fiber link. An inexpensive multimode VCSEL was used to transmit a 50Mbps QPSK signal at an IF of 0.5GHz over 300m of multimode fiber to a remote antenna unit. A 57GHz LO was used to upconvert the IF signal at the remote antenna unit to 57.5GHz. The upconverted signal was wirelessly transmitted to a mobile unit at a distance of 5m. The experiment was repeated with a 100Mbps 16 QAM signal at the same IF frequency of 0.5GHz. The EVM reported for the 50Mbps QPSK and 100Mbps 16 QAM signals were 4.4% and 4.6% respectively. These EVM values are slightly lower than the equivalent measurement in this paper (4.7% and 5% for 40Mbps QPSK and 80Mbps 16 QAM respectively). Note that [14] operates at a higher frequency (57GHz) and longer wireless distance (5m) than the system in this paper. However, the system here operates over a combined 20km single mode fiber and 300m multimode fiber path. In [14], transmission over longer, 600m lengths of multimode fiber was carried out with no noticeable degradation in performance.

V. CONCLUSION

A cost-effective, VCSEL-based mm-wave radio over fiber star-tree architecture has been investigated. The architecture comprises a central office providing indoor coverage to large premises, with the signal distribution between central office and indoor remote antenna units performed using both single mode fiber, for the longer distance distribution, and multimode fiber, for the in-building distribution. The physical layer performance of such a system has been experimentally verified by successful transmission of QPSK, 16 QAM and 64 QAM signals (as used in the WiMAX standard) at 20MSps and 6MSps over the mm-wave optical and wireless links for both downlink and uplink paths. Good signal quality was received for both symbol rates, as evidenced by the low rms EVM values obtained, indicating the feasibility of the architecture. The performance obtained experimentally has been shown to compare favorably with that obtained for other mm-wave over fiber system proposals.

ACKNOWLEDGEMENT

The authors wish to acknowledge the advice and assistance of their colleagues, Professor M. Sobhy, B. Sanz-Izquierdo, M. Mjeku, R. Davis, Dr. D. Wake and A. Jastrzebski. They are grateful to Anritsu EMEA for the loan of a *Signature* vector signal analyzer.

REFERENCES

- [1] IEEE 802.15, "TG3c selection criteria (draft)", *IEEE 802.15 Working Group for Wireless Personal Area Networks*, June 2006
- [2] IEEE Std 802.16 - 2004, includes IEEE Std 802.16c, *IEEE 802.16 Working Group on Broadband Wireless Access Standards*
- [3] ETSI TM4 EN301 213 - 4 v1.1.1 (2001-08), ETSI DVB EN300 748 v1.1.2 (1997 - 1998)

- [4] A. Nkansah, N.J. Gomes, "A WDM/SCM star/tree fibre-feed architecture for pico-cellular broadband systems", *PostGraduate Symposium on the Convergence of Telecommunication Networking and Broadcasting (PGNET)*, pp. 272-276, Liverpool, UK, June 2004
- [5] T. Ismail, C.P. Liu, J.E. Mitchell, A.J. Seeds, X. Qian, A. Wonfor, R.V. Penty, I.H. White, "Transmission of 37.6-GHz QPSK wireless data over 12.8-km fiber with remote millimeter-wave local oscillator delivery using a bi-directional SOA in a full-duplex system with 2.2-km CWDM fiber ring architecture", *IEEE Photonics Tech. Lett.*, vol. 17, pp. 1989-1991, Sept 2005
- [6] A. Kim, Y. H. Joo and Y. Kim, "60GHz wireless communication systems with radio-over-fiber links for indoor wireless LANs", *IEEE Trans Consumer Elect*, vol 50, pp. 517-520, May 2004
- [7] M. Garcia Larrode, A.M J. Koonen, J.J. Vegas Olmos, A. Ng'Oma, "Bidirectional radio-over-fiber link employing optical frequency multiplication", *IEEE Photonics Tech. Lett.*, vol. 18, pp. 241-243, Jan 2006
- [8] P. Hartmann, X. Qian, A. Wonfor, R. V. Penty, I. H. White, "1-20 GHz directly modulated radio over MMF link", *Intl. Topical Mtg. Microwave Photonics*, pp. 95-98, Seoul, Korea, Oct. 2005
- [9] A. Nkansah, A. Das, N.J. Gomes, P. Shen and D. Wake, "VCSEL based single-mode and multimode fiber star/tree distribution network for millimeter-wave wireless systems", *Intl. Topical Mtg. Microwave Photonics*, Paper P6, Grenoble, France, Oct. 2006
- [10] G.H. Smith, D. Novak, and C. Lim, "A millimetre-wave full-duplex fiber-radio star-tree architecture incorporating WDM and SCM", *IEEE Photonic Technol. Lett.*, vol. 10, pp. 1650-1652, Nov. 1998
- [11] T. Kuri, K. Kitayama, and Y. Takahashi, "A single light source configuration for full-duplex 60-GHz-band radio-on-fiber system", *IEEE Trans. Microwave Theory Tech*, vol. 51, pp. 431-439, Feb. 2003
- [12] J.J.J. O'Reilly, P.M. Lane, J. Attard and R. Griffin, "Broadband Wireless Systems And Networks: An Enabling Role For Radio-Over-Fibre", *Philos. Trans. R. Soc. London, Ser. A*, 358, pp. 2297-2308, Aug. 2000
- [13] K. Kojucharow, M. Sauer, H. Kaluzi, D Sommer, F. Poegel, W. Nowak, A. Finger, and D. Ferling, "Simultaneous electrooptical upconversion, remote oscillator generation, and air transmission of multiple optical wdm optical wdm channels for a 60-GHz high-capacity indoor system", *IEEE Trans. Microwave Theory Tech*, vol. 47, pp. 2249-2255, Dec. 1999
- [14] C. Loyez, C. Lethien, R. Kassi, J.P Vilcot, D. Decoster, N. Rolland and P.A Rolland, "Subcarrier radio signal transmission over multimode fibre for 60 GHz WLAN using a phase noise cancellation technique", *Electron. Lett.*, vol 41, pp. 91-92, Jan. 2005
- [15] S. Dupont, C. Loyez, N. Rolland, P.A. Rolland, O. Lafond, and J.F Cadiou, "60 GHz fiber-radio communication system for indoor ATM network", *Microwave Opt. Technol. Lett.*, vol 30, pp. 307-310, Sept. 2001
- [16] M. Iqbal, J. Lee and K. Kim, "Performance comparison of digital modulation schemes with respect to phase noise spectral shape", in *Proc. Electrical and Computer Engineer, Canadian Conf.*, Halifax, NS, Canada, vol. 2, pp. 856-860, Mar. 2000
- [17] A. Hjimiri, "A general theory of phase noise in electrical oscillators", *IEEE J. Solid-State Circuits*, vol. 33, pp. 179-194, Mar. 1998

Anthony Nkansah received the B.Eng (Hons) degree in electronic engineering and the M.Sc in broadband & mobile vommunication networks from the University of Kent, UK, in 2000 and 2001, respectively. Presently, he is studying for the Ph.D degree in electronic engineering at the University of Kent.

His research interests include low-cost microwave and millimeter-wave radio over fiber networks and their deployment within premises.

Anjali Das received the B.Sc (Honours) and M.Sc. degrees in electronic science from Delhi University, Delhi, India, in 1999 and 2001, respectively. She also received the M.Sc. degree in information and communication engineering from the University of Leicester, UK, in 2003. Currently, she is working towards the Ph.D. degree in electronic engineering at the University of Kent, Canterbury, Kent, UK.

Her research interests include low-cost radio over fiber systems and their deployment within buildings for improving coverage.

Nathan J. Gomes (M'92 - SM'06) received the BSc degree from the University of Sussex, UK, in 1984 and the PhD degree from University College London in 1988, both in electronic engineering.

From 1988 to 1989 he held a Royal Society European Exchange Fellowship at ENST, Paris. Since late 1989, he has been a Lecturer, and since 1999, a Senior Lecturer, in the Electronics department at the University of Kent. His present research interests include radio over fiber systems and networks, the photonic generation and transport of millimeter-wave signals, and photoreceivers for such applications.

Pengbo Shen received his B.Eng degree from Shanghai Jiaotong University, Shanghai, China in 1996.

After graduating, he joined Shanghai Jiaotong University as a research engineer on optical communications. In 1999 he joined University of Kent, working on the development of the photonic local oscillator for Actama Large Millimeterwave Array. His research interests are in the field of microwave photonics and communication, including the generation and distribution of high quality millimeter wave signals.