



Kent Academic Repository

Vanhoutte, Sofie, Dhaeze, Wouter and Clercq, Wim De (2009) *The pottery consumption c AD 260-70 at the Roman coastal defence fort, Oudenburg, Northern Gaul*. *Journal of Roman Pottery Studies*, 14 . ISSN 0958 3491.

Downloaded from

<https://kar.kent.ac.uk/72108/> The University of Kent's Academic Repository KAR

The version of record is available from

<https://www.oxbowbooks.com/oxbow/the-journal-of-roman-pottery-studies-volume-14.html>

This document version

Publisher pdf

DOI for this version

Licence for this version

UNSPECIFIED

Additional information

Versions of research works

Versions of Record

If this version is the version of record, it is the same as the published version available on the publisher's web site. Cite as the published version.

Author Accepted Manuscripts

If this document is identified as the Author Accepted Manuscript it is the version after peer review but before type setting, copy editing or publisher branding. Cite as Surname, Initial. (Year) 'Title of article'. To be published in *Title of Journal*, Volume and issue numbers [peer-reviewed accepted version]. Available at: DOI or URL (Accessed: date).

Enquiries

If you have questions about this document contact ResearchSupport@kent.ac.uk. Please include the URL of the record in KAR. If you believe that your, or a third party's rights have been compromised through this document please see our [Take Down policy](https://www.kent.ac.uk/guides/kar-the-kent-academic-repository#policies) (available from <https://www.kent.ac.uk/guides/kar-the-kent-academic-repository#policies>).

The pottery consumption *c* AD 260–70 at the Roman coastal defence fort, Oudenburg, Northern Gaul

Sofie Vanhoutte, Wouter Dhaeze and Wim De Clercq

Summary

A study of military pottery consumption at the transition of the middle to late Roman period based on an important pottery group from a dump of *c* AD 260–70 at the Roman Saxon Shore fort at Oudenburg, West Flanders, Belgium

The Oudenburg castellum and the context of the pottery dump

Oudenburg (Province of West-Flanders) is situated 8km from the Flemish coastline, in the polder area between Ostend and Bruges (Fig 1). In Roman times the site was strategically positioned on an elevated sandy ridge of

mudflats and marshes intersected by natural gullies overlooking the Coastal Plain (*see* Mostaert 2000, 4).

Long before the first excavations took place it has been assumed that there was a Roman fort at Oudenburg on the basis of toponymic, topographic and historic sources together with Roman finds recorded since the 17th century. Excavations in the 1950's proved the presence of the fort and research in the 1950's, 60's and 70's by Joseph Mertens located several successive *castella*, with two related military cemeteries more than 400m to the west of the fort as well as the remains of an older civil settlement (Mertens 1977, 1980, 1987; Mertens and Van Impe 1971; Creus 1975). Mertens concluded that Oudenburg had had a long military history from the late

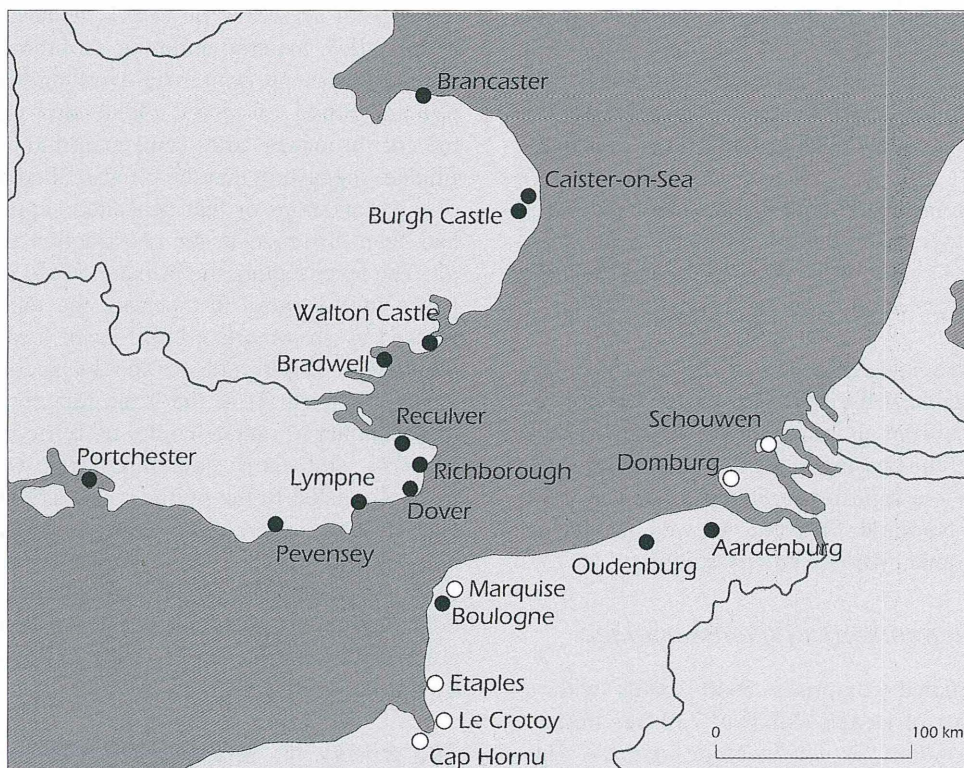

Fig 1: Locations of Oudenburg, Aardenburg, Domburg and Schouwen, the Saxon Shore forts in Britain and the presumed Saxon Shore forts of Belgica Secunda

2nd century until the beginning of the 5th. The plan of the fort, its topographical position and several finds suggest that the stone fort of Oudenburg formed part of the *Litus Saxonicum*, the defensive system along the Channel, together with the Saxon Shore forts along the southern shores of Britain. At the beginning of the 1990's a civil cremation cemetery and traces of a civil settlement, both dating to the 2nd and 3rd centuries AD, were found to the south of the fort (Hollevoet 1992 and 1993).

A planned building project on the south-west corner of the fort provided a unique opportunity for large-scale archaeological research and a chance to investigate in detail the spatial organisation of a Roman fort of the coastal defence system. An archaeological rescue campaign at Oudenburg-Spegelaere (the site was named after the planned new supermarket) was carried out by the Flemish Heritage Institute (VIOE) between August 2001 and April 2005. These excavations produced evidence for a sequence of possibly three turf and timber *castella* and two stone forts of c 153x176m. The latest phase, dating to the 4th century AD was presumed to be a part of the *Litus Saxonicum*. The stone fort was defended by a presumed double ditch of almost 30m wide (Vanhoutte 2007) (Fig 2: features 1 and 2). There are various indications that the shift towards stone defences had already taken place in the second half of the 3rd century as was the case for the forts in Britain (Pearson 2002, 65). Mertens discovered the remains of a stone building dating to this first stone-fort phase along one of the main roads of the fort (Mertens 1980, 463) (Fig 2: feature 3). The three preceding turf and timber forts are likely to have been elements of an older coastal defence system along the Gaulish and British coastline.

The information presented here is a detailed study of a pottery assemblage from a large pit in the south-west corner of the first stone-fort phase of the coastal defence fort at Oudenburg recovered during these excavations.

This study is an important aspect of the ongoing *post-excavation*-research of the Oudenburg site. The pottery presented here is from an important key context for the understanding of the phasing of the fort occupation. Also the assemblage is a significant reference collection for this period in Northern Flanders, as well as having relevance for Romano-British pottery studies.

Context and taphonomy of the assemblage

The pottery studied comprises 5640 sherds with a minimum number of vessels (MNI) of 739 (see *Pottery study methods below for methodology details*). This pottery assemblage was collected from pit OS 4980 (OS = Oudenburg-Spegelaere), located in the south-west corner of the fort, just within the earthen rampart (Fig 2:

feature k; Fig 3). OS 4980, a large bowl-shaped pit, was originally approximately 10x10m dug to a depth of 1.7 m (Fig 4) with a rather flat bottom. The sections through the structure are not central due to the constraints of the excavation. They show that the primary filling of the pit had an average thickness of around 0.75m, increasing in some places to 1m. The layers of the primary fill consisted of dark compact organic clay layers, alternating with a few more sandy levels and with several shell concentrations of mussels and cockles, assumed to be consumption waste. These primary fillings were sealed by later layers of pit fill. OS 4980 was partly cut by the circular construction pit of a large wooden basin 4.5m square, during the last phase of the fort (see Fig 2).

The stratigraphic relationships of pit OS 4980 to other excavated features show it to have been dug in the penultimate fort period. The primary filling of the pit only yielded two badly preserved coins: a sestertius of the 1st or 2nd century AD (perhaps Trajan) considered to be a residual, redeposited piece, and a sestertius only generally datable in the period mid 2nd to c 270 AD. During this penultimate fort period this south-west area was reserved for industrial activities, with more than 20 workshops (furnaces and hearths: Fig 2, features a, c, f, g, i), presumable storage places (Fig 2, feature h) and a well (Fig 2, feature j), and a possible living-quarter more to the east (Fig 2, feature l). Pit OS 4980 just cuts the edge of a shallow pit (Fig 2, feature b) filled with copper-alloy material pointing to brooch production, clearly a waste pit from metal-working in this area. The primary filling of pit OS 4980 also yielded several unbent brooches and semi-manufactured parts of fibulae, suggesting that the pit was filled during the life of the workshops or that deposited copper-alloy waste had been disturbed in the construction process of this pit. The level sealing the primary filling dates to a later phase of the same fort period, the end of which is marked by an important burnt layer, locally attested in other areas. This burnt layer and the layers overlying the abandoned well (j) of the same fort period, yielded a large number of radiate copies of Tetricus I and II (AD 271–74) and their contemporaries which can be generally dated to the period c AD 275–300 (Dr J van Heesch *pers comm*). An oak beam, found as recycled construction material in a secondary deposit, had a felling date which could be dated to c AD 266 by dendrochronology (Vanhoutte *et al in press*), providing confirmation for the dating of this fort period suggested by the *in situ* information.

The primary pit filling of OS 4980 was sealed by secondary levels in the last phase of the penultimate fort and again during its final period of occupation (4th century AD). The pottery from these sealing layers is

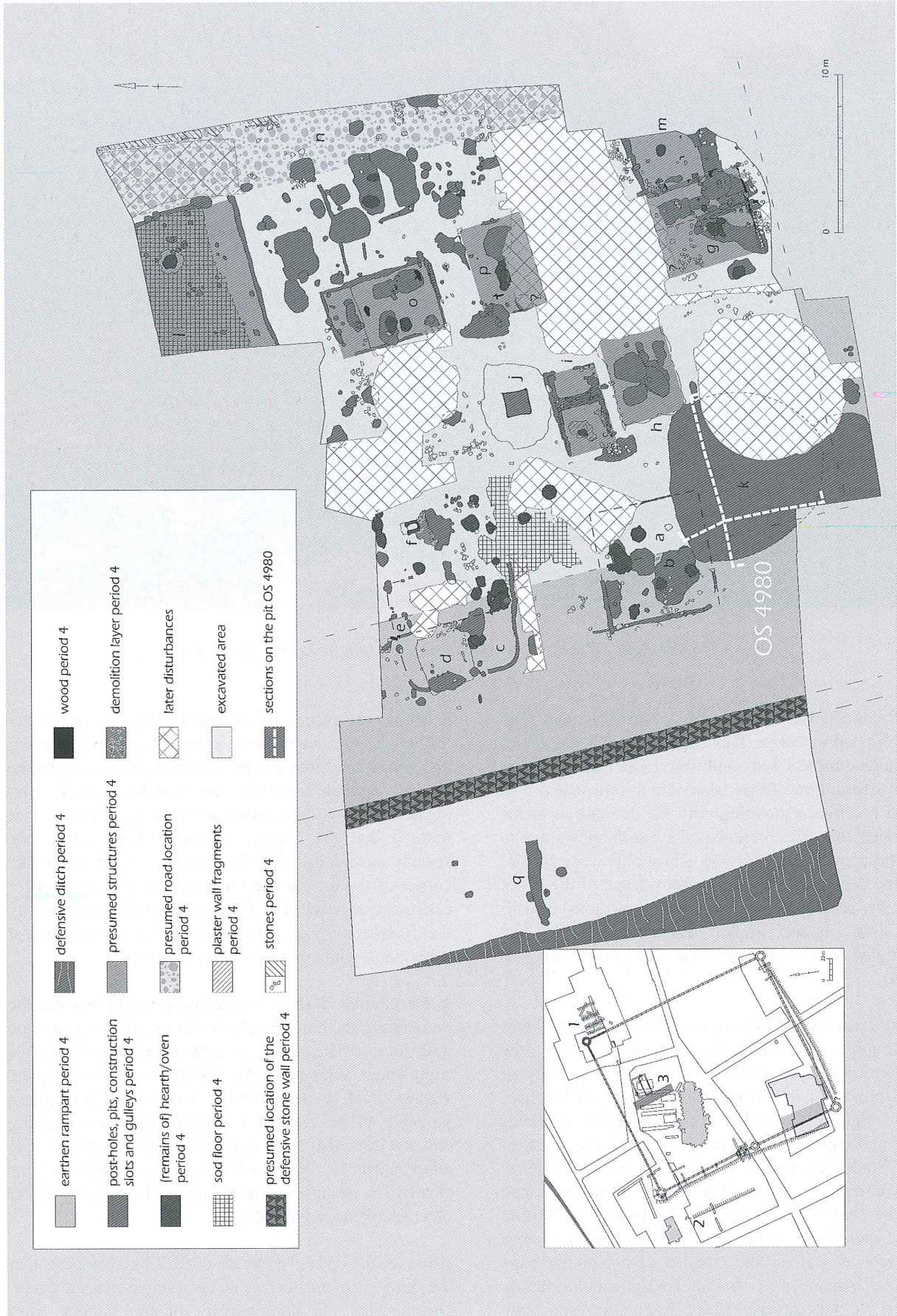

Fig 2: Area excavated during the 2001–05 archaeological campaign (inset) and simplified excavation plan of the 4th fort period at Oudenburg



Fig 3: OS 4980 pit: view of the west–east section (photo: copyright VIOE)

more fragmented and sherds have fewer fresh breaks and more abraded surfaces. This suggests that these levels accumulated more slowly and were more exposed to the elements for a time. These layers are in turn sealed by a rubbish level corresponding with the demolition of the abandoned fort. The presence of a hearth shows this to be an occupation level (Fig 4). During the early Middle Ages the depression formed by subsidence of the fill of the pit was levelled. Lastly two well-constructed hearths were sited on top of the depression during late Carolingian times (of which one was cut by the N–S section).

The large number of finds suggests that pit OS 4980 was a waste-pit. As well as a large amount of pottery, the primary fillings also yielded an enormous quantity of animal bones, mainly from consumption and butchery waste; a significant number of tile fragments; hundreds of iron and copper alloy pieces; two small fragments of human skull, presumably redeposited; and three more-or-less complete copper-alloy vessels were excavated from the centre of the pit (Fig 4). Dozens of leather pieces including some from several shoes were recovered, as well as the remains of a wooden bowl (oak) with a diameter of *c* 0.45m, a fragment of a smaller wooden vessel, several glass fragments, six bone

hairpins, six pieces of millstones, dozens of plaster fragments, two whetstones, a ceramic gaming counter, and two coins. Although the copper-alloy vessels and the almost-complete ceramic and wooden vessels first seemed to have originated as a ritual deposit, it is thought that the number of finds, their variety, the several cross-joins and the location of the pit in the corner of the fort indicate that this pit was a dump for consumption waste. This does not exclude the possibility that ritual activity of some kind may have taken place at some point while pit OS 4980 was in use.

It appears that all these objects had been thrown into the pit deliberately, immediately or shortly after they became unfit for use. The pottery includes many large potsherds, from which complete pottery profiles or almost complete vessels could be reconstructed. The deposit is therefore probably to be seen as a primary deposit containing material discarded away immediately after breakage. The almost-intact Dr 38 and a few *mortaria* demonstrate this clearly. The freshness of the breaks and lack of wear of the other sherds underlines this.

However the layered structure of the filling suggests that the dump was not the result of a single discard event. Despite this the homogeneity of the pottery from

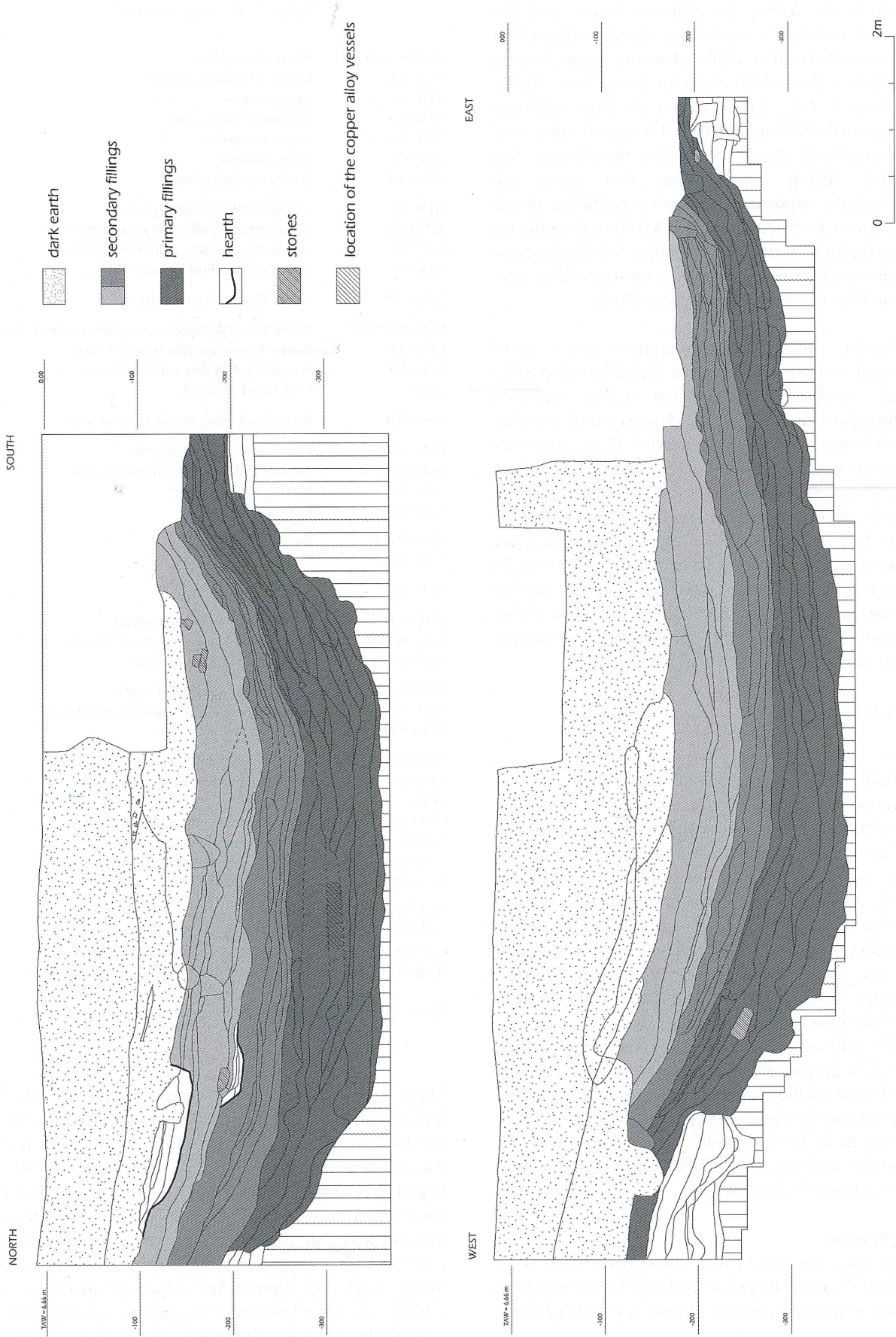

Fig 4: North-south and west-east sections of the OS 4980 pit with location of the copper alloy vessels

different layers within the primary filling and the occurrence of several cross-joining sherds, indicate that the pit was filled within a quite short time-span. Joining sherds from a Dressel 20 amphora and a Niederbieber 33b colour-coated beaker, recovered from different layers within this filling, illustrate this well. (Only a very few cross-joining sherds came from the primary and secondary fillings, underlining that these are chronologically separate. The few cross-joining sherds are to be seen as residual, redeposited from the primary filling to the later secondary pit fillings. A few rare cross-joins between later deposits and the primary filling may be due to human failure during excavation).

The primary filling also contained some more fragmented material and this was probably redeposited residual material derived from earlier deposits elsewhere, perhaps from surface clearance or from other refuse or waste accumulations nearby. These potsherds do not form complete profiles and have no cross-joining pieces. Some ceramic sherds show traces of having been previously deposited outside the fort. Three potsherds were covered by the remains of chalk plates of sea pox or of small moss creatures (identification by A Ervynck, Flemish Heritage Institute), indicating that they lay for some time in brackish or sea water (it is unclear if this was before or after breakage) before they were brought back into the fort to be thrown away.

Methodology

Fabrics

The 5640 ceramic sherds of the pottery dump, representing a MNI of 729, were grouped into fabrics. Fresh breaks were systematically observed under the binocular microscope (X10–40). The fabric codes of Tomber and Dore 1998 were used as much as possible (Table 1). New codes were created for fabrics not listed in Tomber and Dore (*ibid*), where possible using the same coding system with characters 1–3 indicating the source area, and characters 4–6 denoting the technology. The fabrics listed in Tomber and Dore (*ibid*) are only briefly described, whereas the new fabrics are discussed in detail, following the system proposed by Peacock (1977a). The flagons were not catalogued in the group of oxidised ware as they are in Tomber and Dore (1998), but in a separate group as are the dolia. In total 39 fabrics are present in the OS 4980 pottery assemblage (Table 1). Undetermined fabrics, coded UND, are not included in the fabrics listed in the table.

Quantification

After dividing the sherds into fabric types, they were quantified. Two quantification methods were used: sherd count and minimum numbers of vessels (MNI) (Table 2 and 3).

Table 1: Fabrics present

<i>Fabric code</i>	<i>Short description</i>
LEZ SA	Central Gaulish samian
TRI SA	Trier samian
RHZ SA	Rheinzabern samian
ARG SA	Argonne samian
BLA SA	black samian
NOG SA	North Gaulish samian
KOL CC	Cologne colour-coated ware
MOS BS	Moselkeramik black-slipped ware
LNV CC	Lower Nene Valley colour-coated ware
NFO CC	New Forest colour-coated ware
NOG TR	North Gaulish terra rubra
NOG SAP FO	North Gaulish saponaceous fine oxidised ware
NOM FR	North Menapian fine reduced ware
NOG FR	North Gaulish fine reduced ware
LLW1	Low Lands Ware 1
IMP PRG	Rues-des-Vignes pompeian red ware
LLW1 FL	Low Lands Ware 1 flagons
NOG SAP FL	North Gaulish saponaceous flagons
MEV FL	Meuse Valley flagons
KOL FL	Cologne flagons
BAT AM II	Baetican amphorae 2
GAL AM I	Gaulish amphorae 1
NOG DOL	North Gaulish dolia
SOL WH	Soller White ware (mortaria)
MEV WH	Meuse Valley White ware (mortaria)
BAV OX	Bavay oxidised (mortaria)
URM OX	Urmitz coarse oxidised ware
RME OX	Rhine-Meuse-Eifel coarse oxidised ware
MAY CO	Mayen coarse ware
NOM RE	North Menapian coarse reduced ware
ATR RE	Atrebatian coarse reduced ware
LLW1	Low Lands Ware 1
CALO RE	La Caloterie coarse reduced ware
NOMO RE	North Morinian coarse reduced ware
CAM RE	Cambrai coarse reduced ware
UND RE	?Colchester black-burnished ware 2
NOM HA 1	North Menapian handmade ware 1
NOM HA 2	North Menapian handmade ware 2
NOM HA 3	North Menapian handmade ware 3
DOR BBI	South-East Dorset black-burnished ware 1

Fabric codes in bold are listed in Tomber & Dore 1998

Sherd count is the simplest quantification method. In this case all individual sherds were counted regardless of the number of joining sherds identified. This does have the disadvantage that vessel or fabric types with a high degree of fragmentation may be over-represented in comparison to those with a lower level of brokenness. This method also gives a biased representation to large vessels, such as amphorae and storage jars, however recent work has shown that counting sherds is as reliable as other methods of pottery quantification commonly in use (Symonds and Haynes 2007).

Table 2: Quantification of pottery types present

<i>Fabric Group</i>	<i>Sherd-count</i>	<i>%</i>	<i>MNI</i>	<i>%</i>
Samian ware	245	4.34	89	12.04
Colour-coated & Black-slipped ware	31	0.54	15	2.02
Terra rubra	1	0.01	1	0.13
Fine oxidised ware	1	0.01	1	0.13
Fine reduced ware	287	1.50	27	3.65
Pompeian red ware	3	0.05	2	0.27
Flagons	652	11.56	21	2.84
Amphorae	106	1.87	10	1.35
Dolia	4	0.07	1	0.13
Mortaria	44	0.78	7	0.94
Coarse oxidised ware	10	0.17	6	0.81
Coarse reduced ware	1882	33.36	261	35.3
Handmade ware	2374	42.09	298	40.32
Totals	5640	99.85	739	99.93

Table 3: Quantities of pottery by fabric type

<i>Pottery group</i>	<i>Fabric code</i>	<i>Sherd-count</i>	<i>MNI</i>
Samian ware	CNG SA	4	2
	RHZ SA	103	36
	TRI SA	97	38
	RHZ SA/TRI SA	4	3
	ARG SA	6	4
	NOG SA	4	2
	BLA SA	1	1
	UND SA	26	3
	Totals	245	89
Colour-coated & Black-slipped ware	KOL CC	1	1
	MOS BS	13	4
	LNV CC	11	4
	NFO CC	1	1
	UND RS	1	1
	UND CC	2	2
	UND CC/UND BS	2	2
	Totals	31	15
Terra rubra	NOG TR	1	1
Fine oxidised ware	NOG SAP FO	1	1
Fine reduced ware	NOM FR	274	22
	NOG FR	5	1
	LLW1	8	4
	Totals	287	27
Pompeian red ware	RDV PR	3	2
Flagons	LLW1 FL TW	275	12
	NOG SAV FL TW	1	1
	KOL FL TW	1	1
	MEV FL TW	1	1
	LLW1 FL SW	119	4
	LLW1 FL TW/SW	255	2
Totals	652	21	
Amphorae	BAT AM 2	102	6
	GAL AM 1	4	4
	Totals	106	10
Dolia	NOG DOL	4	1

The MNI was estimated by separating the sherds into groups representing individual vessels.

The calculation was primarily based on diagnostic sherds (rim, base, handle and distinctive wall sherds of decorated vessels). This method also has disadvantages. The exact number of vessels present can only be estimated. Also the calculation is biased in favour of decorated vessels, eg individually distinctive vessels like decorated Drag 37 bowls are more easily identified than plain ones. However the different biases of the two methods can partly be compensated for by comparison of the results of the two quantification methods.

Presentation

The pottery from pit OS 4980 has been subdivided and ordered by fabric and in a range from fine to coarse wares as follows: samian; colour-coated and black-slipped; terra rubra; fine oxidised; fine reduced; flagons; amphorae; dolia or storage jars; mortaria; coarse oxidised; coarse reduced; and finally handmade wares. Each section describes the various fabrics and types and discusses their dates and functions. A concluding section discusses the significance of the pottery assemblage for understanding the Oudenburg fort and also its importance for pottery research in northern Gaul and beyond.

<i>Pottery group</i>	<i>Fabric code</i>	<i>Sherd-count</i>	<i>MNI</i>
Mortaria	SOL WH	21	3
	MEV WH	17	1
	MEV MOR/SOL MOR	1	1
	UND MOR	5	2
	Totals	44	7
Coarse oxidised ware	MAY CO	1	1
	URM OX	1	1
	RME OX	1	1
	UND CO	7	3
	Totals	10	6
Coarse reduced ware	NOM RE	1824	233
	LLW1	2	1
	ATR RE	33	14
	CALO RE	3	2
	ARD RE	11	7
	CAM RE	3	1
	UND RE 1	3	2
	UND RE	3	1
Totals	1882	261	
Handmade ware	NOM HA 1	666	100
	NOM HA 2	1424	178
	NOM HA 3	243	13
	DOR BB1	23	6
	UND HA	18	1
Totals	2374	298	
Overall totals		5640	739

The pottery

Samian

A considerable quantity of the sherds recovered from pit OS 4980 consists of samian pottery (Figs 5 and 6): in total 245 sherds (4.34%) and MNI 89 (12.04%). Many sherds are burnt, some of them on the footing. The samian group offers new insights into the consumption of this ware in mid-to-late 3rd century contexts in Northern Flanders, but also sheds an important light on the later phases of production and export of samian from the Trier and Rheinzabern workshops. The analysis below is based on the MNI quantification of the assemblage. However, more general features, observed for individual sherds within each type, have also been taken into account in discussing the types and fabrics. The drawings of the samian pottery are classified according to the fabrics in which the different vessel types are shown.

Fabrics

Several samian pottery fabrics were identified. The Trier (TRI SA) (42.7% by MNI) and Rheinzabern (RHZ SA) (40.4% by MNI) products dominate the group and are equally represented, while vessels originating from the Argonne (4.5% of the MNI), Central-Gaulish (CNG SA) (2.2% by MNI) and North-Gaulish workshops (NOG SA) (2.2% by MNI) were found in very low quantities. The fabric of some sherds could not be determined since they were heavily burnt (25 sherds) or there was uncertainty as to nature of the inclusions (3 sherds) (in total 6.7%). Fresh breaks were compared to the Tomber and Dore (1998) and Bird (1993) descriptions and are described below accordingly with any additional observations and comments added.

CNG SA: Pale red-brown coloured fabric containing various ill-sorted inclusions amongst which are silver

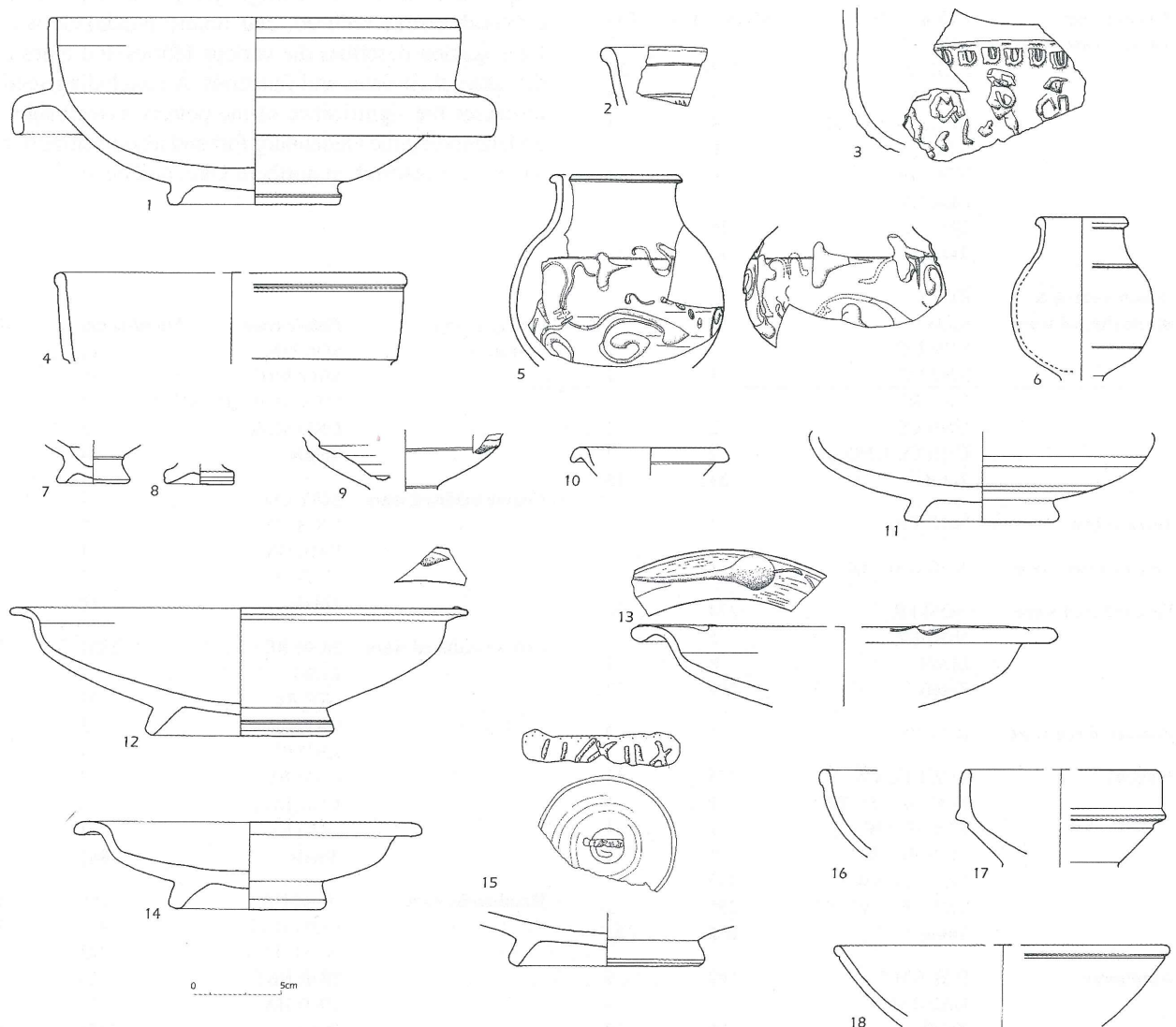

Fig 5: Samian: Central Gaulish (no 1) and Rheinzabern (nos 2–18) fabrics, scale 1:4. Stamps 1:1

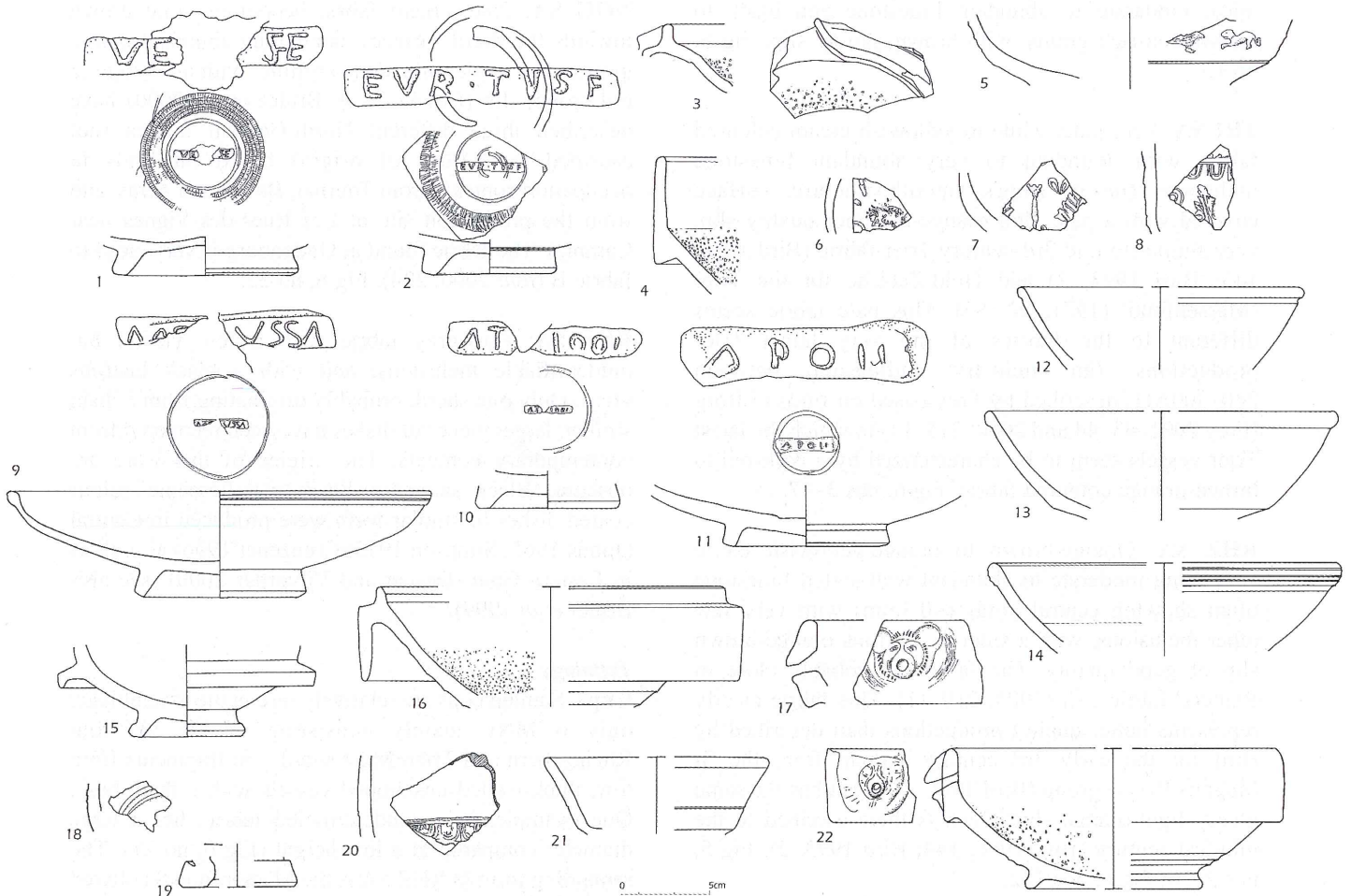

Fig 6: Samian: Rheinzabern (nos 1–2), Trier (nos 3–17), Argonne (nos 18–19), undetermined (nos 20–21) and North Gaulish (no 22) fabrics, scale 1:4. Stamps 1:1

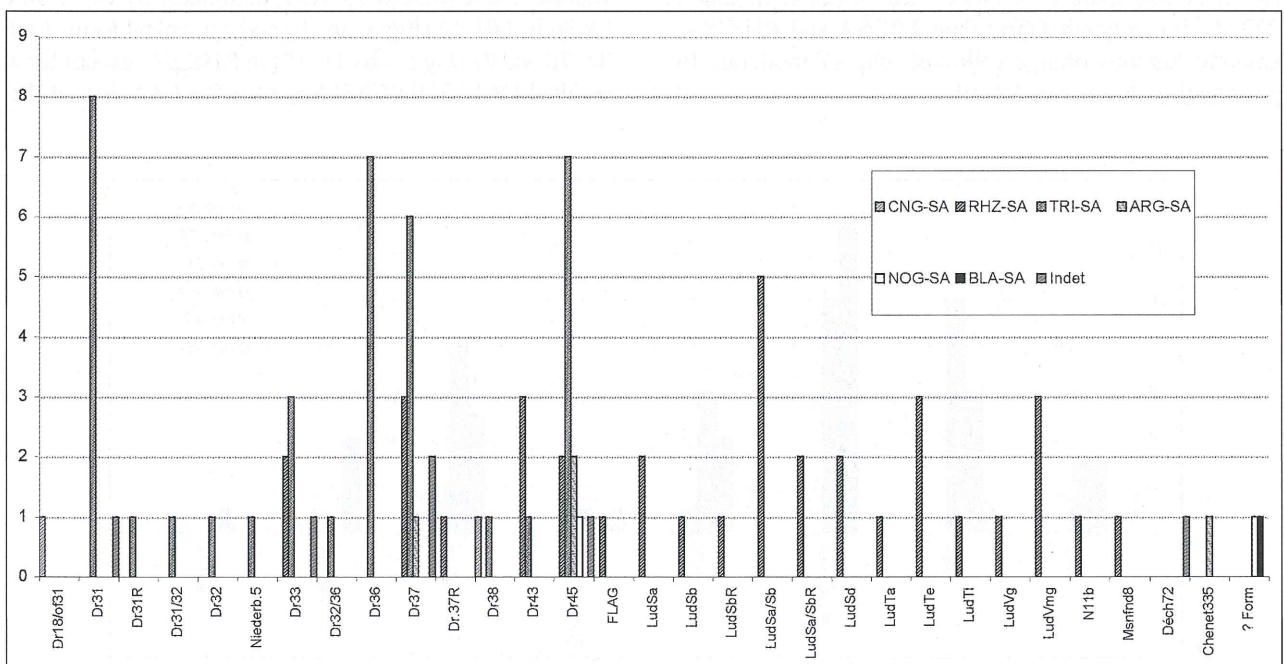

Fig 7: Samian forms present by fabric based on MNI

mica, moderate to abundant limestone and black to brown iron-rich grains, with brown, glossy slip. Fig 5, no 1.

TRI SA: Very pale, white to yellowish-cream coloured fabric with abundant to very abundant limestone inclusions (up to 1mm), smooth fracture, surface covered with a pale, dull orange-red poor quality slip, very similar to mid-3rd-century Trier fabric (Bird 1986, 143; Bird 1993, 2) and Huld-Zetsche for the Trier 'Massenfund' (1971, 22, 85). This pale fabric seems different to the fabrics of the very latest Trier productions (an industry fading-out between 260–300AD) described by Frey based on finds in Borg (Frey 2001, 43–44 and 2000, 213–14) in which the latest Trier vessels seem to be characterized by a dark-red to brown-orange coloured fabric. Fig 6, nos 3–17.

RHZ SA: Orange-brown to orange-yellowish fabric containing moderate to abundant well-sorted limestone often showing central voids (<0.3mm) with very few other inclusions, with a smooth, lustrous orange-brown slip of good quality. The fabric is probably close to Reuters' fabric 2–3 (2005, 210–11). This fabric clearly represents better quality productions than described by Bird for the early 3rd century samian from the St Magnus House group (Bird 1986, 144) but has the same glossy light-orange slip which is there ascribed to the mid-3rd century (Bird 1986, 144; Bird 1993, 2). Fig 5, nos 2–18; Fig 6, nos 1–2.

ARG SA: Orange-yellow fabric containing few visible inclusions except for some quartz grains or sparse micas (for a petrographic description: see Brulet *et al* 2000, 223–4), less smooth fabric than TRI SA and RHZ SA, smooth, lustrous orange-yellowish slip of moderate to poor quality. Fig 6, nos 18–19.

NOG SA: Pale, cream fabric becoming more brown towards the sherd surfaces, containing abundant quartz grains, iron oxides and some argillite, with an orange to red-brown slip (Col Pl 2, a). Brulet *et al* (2000) have described three different North-Gaulish fabrics (not ascribed to regions of origin) based on finds in occupation contexts from Tournai, Bavay and Arras, and from the production site at Les Rues-des-Vignes near Cambrai. The fabric found at Oudenburg is very close to fabric B (*ibid* 2000, 224). Fig 6, no 22.

BLA SA: Buff-grey fabric with a few visible but unidentifiable inclusions, and with a black lustrous gloss. Only one sherd, probably originating from a dish; similar, larger pieces of dishes have been recovered from contemporary contexts. The origins of this ware are obscure. 'Black' samian or black 'métallescente' colour coated dishes of similar form were produced in Central (Johns 1963; Simpson 1973; Creuzenet 1996) as well as in Eastern Gaul (Desbat and Vilvorder 2000) (see also Brulet *et al* 1999).

Typology

Cups: Samian cups are relatively rare in the assemblage, only 6 MNI, mainly consisting of Dr 33 from Rheinzabern and Trier. Most sherds are fragments from low, thick-walled unstamped vessels with a thick base. One example, in an undetermined fabric, has a large diameter compared to a low height (Fig 6, no 21). The remaining form in RHZ SA is the Massenfund 8 collared cup (Fig 5, no 17) dated to the middle of the 3rd century (Huld-Zetsche 1971; Reuter 2005).

Dishes: These totalled 18 MNI, dominated by Dr 32 and Dr 36 in TRI SA (Fig 6, no 10) and equivalent forms Lud Ta, Te and Ti (Fig 5, nos 11–15) in RHZ SA, except for a residual Dr 18/31 in CNG SA. One RHZ SA dish of the

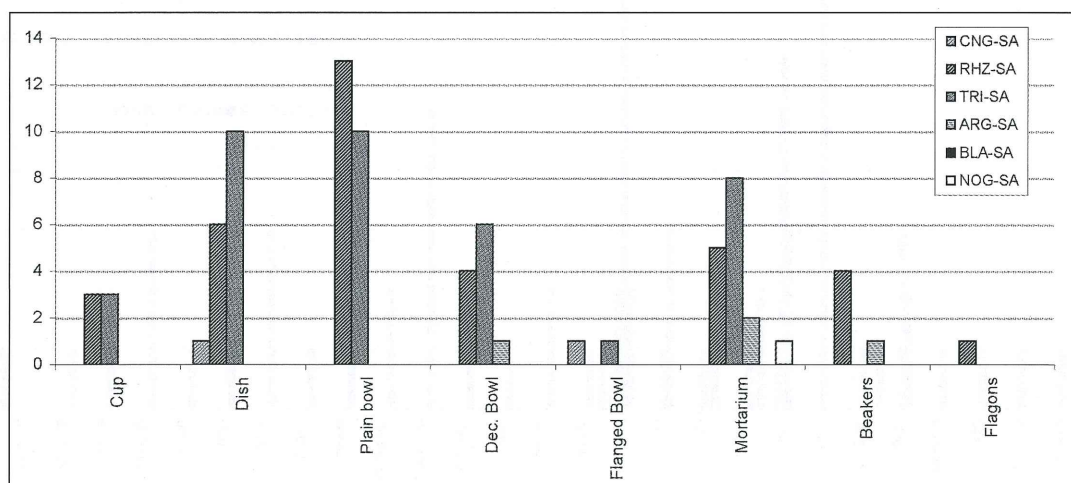

Fig 8: Samian fabrics and forms by function types based on MNI

Lud Ta or Te type was stamped with the illiterate stamp IIXVIIIX (Fig 5, no 15). Another Lud Te bears a line-stamp (or Strichstempel), a characteristic feature dated to the mid-3rd century (Bird 1993, 3). Another Dr 32 or 36 in TRI SA was stamped ATILLIDOF (Fig 6, no 10), a potter also found in Niederbieber (but not from the same die) (Oelmann 1913, taf 9, 2). A stamp ME[.]VSSA on a Niederbieber 5b most probably reads MERCVSSA (Fig 6, no 9) (A potter unknown to Dr I Huld-Zetsche (*pers comm*), Dr B Dickinson provided the identification of the stamp, but the die has no parallel). A similar but complete stamp was found on a Dr 32 in a nearby and contemporary well at the Oudenburg site (Fig 2, feature j). Both forms are abundant in 3rd century contexts. Form Dr 32 (Lud Ta) is a characteristic 3rd century form. It is also abundant in the Regensburg Graspasse (dated AD 278–81: Reuter 2005). Niederbieber Form 5b is a close variant of the Dr 32 type but has an almost beaded rim (Fig 5, no 18). Form Dr 36 (Lud Te) already in production in the 1st century was still being made in the 3rd century. Finds at Trier (Huld-Zetsche 1971, type 10a) and Pforzheim (Körtüm 1995, 241) seem to indicate that the latest Dr 36 vessels were produced until the middle of the 3rd century. The Oudenburg examples are from large dishes, in some cases without the barbotine leaves on the rim (Fig 5, no 14). A remarkable dish is the small, footless Niederbieber 11b, Massenfund 6, Gose (1950) Type 44 (Fig 5, no 10) in RHZ SA. Finds at Pforzheim (Körtüm 1995), Langenhain (Simon and Koller 1992), Trier (Huld-Zetsche 1971), Holzhausen (Pferdehirt 1976) and London (Bird 1986) suggest that this form was introduced during the 2nd quarter of the 3rd century and was still in use during the mid-3rd century. The small dish is, however absent from Regensburg-Graspasse, dated to the years AD 278–81 (Reuter 2005).

A small wall-fragment (*not illustrated*) from context OS 4980 is an example of a remarkable series of dishes in 'black samian' (BLA SA), with elaborate barbotine decoration. More complete examples were found in other contemporary contexts at Oudenburg.

Plain bowls: There were 19 MNI of deep dishes or plain bowls. Of these, eight Dr 31 and one Dr 31R were in TRI SA (Fig 6, nos 11–14). A stamp reading APOLI on the base of a Dr 31 (or 32) (Fig 6, no 11) remains unparallelled, and this potter is not known to Dr I Huld-Zetsche (*pers comm*).

Bowls Lud Sa and/or Lud Sb and the rouletted variant Lud SbR are well represented in RHZ SA (Fig 5, no 16, Fig 6, nos 1–2). Two Lud SbR sherds are stamped; VE[.]SF (Fig 6, no 1) reads as VERVS from Rheinzabern (Oswald 1931, 332; Ludowici (1912) 4, 64, stamp 8345). A stamped vessel from VERVS was found at the Trier Louis-Linz-Strasse (Loescke 1923) in a find

context dated to AD 260–75. The die differs from the Oudenburg piece and it is not clear if this potter moved from Rheinzabern to Trier or not (Dr I Huld-Zetsche *pers comm*). Another stamp on a Lud SbR reads EVRITVSF (Fig 6, no 2), a potter known to have worked in Rheinzabern (Oswald 1931, 117) during the 3rd century (Dr I Huld-Zetsche and Dr M Thomas (*pers comm*)).

Dr 31 or the Rheinzabern equivalents Lud Sa/b are characteristic bowls/deep dishes of the late 2nd century and early to mid-3rd century. They were produced (at least) until the second quarter of the 3rd century (Pferdehirt 1976, 67) but were gradually replaced by the Dr 32 by the middle of the 3rd century (Reuter 2005, 218). However, sherds of Dr 31 are still present in some later assemblages such as the Trier Louis-Linz-Strasse-complex, dated AD 259–60 by Loescke but put somewhat later, cAD 275, by Gard (Loeschke 1923, taf 11; Gard cited by Huld-Zetsche 1971, 23) and in other contexts of the 3rd quarter of the 3rd century.

Decorated bowls: There were 11 (MNI) decorated bowls; four MNI in RHZ SA, six in TRI SA and one in ARG SA, together with some heavily burnt sherds and one in an undetermined fabric (Fig 6, no 20). The Argonne piece (Fig 6, no 18) is a small (residual?) fragment, probably representing a human figure in a double medallion. The Rheinzabern sherds are very fragmented and the decorative schemes remain unidentified, except for one sherd, with a repetitive combat-scene between two gladiators and a series of blurred ovolos (type Ricken and Fischer 1963: E17 or 23?) (Fig 5, no 3). The gladiator fighting to the left (type Ri-Fi M216a) and his opponent to the right (type Ri-Fi M227a) are well known in the decorative repertoire used by the late Rheinzabern group of potters, including the Julius II–Julianus I group. This group is dated by Simon (1968, 22) and Bernhard (1981, abb. 3) to after 233 AD and is well represented in contexts dated in the second third of the 3rd century (c AD 233–60/270, eg the London New Fresh Warf group, dated to AD 235–45 by Bird (1986, 143), see also Bird (2002, 34–35) and Scholz (2006, 36) with reference to other authors dating the Julius II–Julianus I group between AD 210/230 and 260/270).

One rim sherd in RHZ SA was identified as a Dr 37R (Fig 5, no 2), a low small and rouletted version of the Dr 37 (Oswald and Pryce 1920, 221–23, pl 75). Another rim fragment (Fig 5, no 4) shows a high, flaring rim. The Niederbieber form 16 and several finds such as the Langenhain cellar-find (Simon and Kohler 1992, taf 39) prove that this form was still in use during the 3rd century. Less fragmentary wall-sherds of some TRI SA Dr 37 (Fig 6, nos 6–8) occur, depicting animals, leaves and columns. Some motifs such as the panther (Fölzer

1913, 594) and bird (Fölzer 684), a large triangular leaf (Fölzer 776?) or a double-leaf (Fölzer 907) are typical decorative elements of the 3rd century Trier workshops. Dr I Huld-Zetsche (*pers comm*) could not suggest known potters for any of the Trier decorated sherds. According to Bittner (1986) the production of mould-decorated forms in Rheinzabern stopped in the years around AD 260. Trier workshops were still producing Dr 37 at that time, probably until the end of the 3rd century (Frey 2000).

Flanged bowls: Collared bowls are rare in the assemblage. They consist of two Dr 38 in TRI SA and CNG SA fabrics and two Lud Sd in RHZ SA. The large Dr 38 in CNG-SA (Fig 5, no 1) is an almost complete vessel showing intense traces of use. Cut-marks and an eroded slip in the interior seem to indicate that this piece was in use for a long time before its deposition. The lack of a bead-rim could be an indication for a 3rd-century date (Bird 1993, 10). The shallower Dr 38 with square flange (Fig 6, no 15) also seems typologically indicative of later, *c* 3rd century, productions (Huld-Zetsche 1971, type 15; Bird 1993, 10). Dr 38 flanged bowls are very common in contexts of the 2nd century and first-half of the 3rd century but become rare in the second-half of the 3rd century. Production in Rheinzabern must have come to a halt by the middle of that century (Kortüm 1994, 251). However, the Trier Massenfund (Huld-Zetsche 1971, 34, type 15) and the Louis-Linz-Strasse-complex (dated AD 259 or 260–75) (Loeschke 1923, taf 11, 10) suggest that this form was still produced in Trier in the 3rd quarter of the 3rd century.

Mortaria: Mortaria in samian are particularly well-represented in the Oudenburg OS 4980 group. 17 MNI were present, two Dr 45 and three Dr 43 in RHZ SA (Fig 6, nos 3–4), seven Dr 45 and one Dr 43 in TRI SA (Fig 6, nos 16 and 17); two Dr 45 in ARG SA, one Dr 45 in NOG-SA (Fig 6, no 22) and one burnt and hence unidentified fragment. Many sherds show traces of heating or burning, some footings are heavily worn. The form was introduced in Lezoux during the last quarter of the 2nd century but was mainly produced during the 3rd century. The flanged version, Dr 43 was also in use during all of the 3rd century. In the Regensburg-Grasgasse (dated AD 278–80) this mortarium is still well represented. The bat-like appearance of the spout on a TRI SA Dr 45 (Fig 6, no 17) points to a date in the first half or middle of the 3rd century (*cf* Bird 1986, 213–6; 1993, 8; Huld-Zetsche 1971, type 14). A 3rd century chronology is furthermore confirmed by the presence of a Dr 45 imitation in North Gaulish Samian (*see* Brulet *et al* 1994; Brulet *et al* 2000).

Beakers: There are 5 MNI beakers, four in RHZ SA (LudVg and Vmg: Fig 5, nos 5–8), one in ARG SA

Chenet (1941) form 335 (Fig 6, no 19). Chenet Form 335 was made during the 3rd century in the Lavoye workshops (*ibid*, 85) and continued to be produced in the following century. The high-quality LudVm and LudVmg (decorated with barbotine leaves and scrolls) (Niederbieber 24) are characteristic mid-3rd century beakers. Production ended in the period between the last 3rd of the 3rd century and the beginning of the 4th (Reuter 2005, 224). Some footings (Fig 5, nos 7–8) could belong to other LudVm variants (a, c, or d).

Flagons: 1 MNI of a possible flagon was found (Fig 5, no 9). The thick walled sherd in RHZ SA has an indentation in the wall and shows heavy throwing-marks. Flagons (eg Niederbieber 27) are essentially mid-3rd century and later (Reuter 2005, 225).

Discussion

Based on fabric, both the RHZ SA and TRI SA wares indicate a mid-3rd century date for the assemblage. The Rheinzabern fabric appears similar to that recorded at the mid-3rd century St. Magnus House site or in the Regensburg-Grasgasse-group (*c* AD 278–80). The pale Trier fabric however clearly coincides with the Massenfund-group (*c* AD 240–60) but differs completely from the Späten Ware, described by Frey (2000) and dated AD 260–300.

The typologically equally divided proportions of the Dr 32 and 36 dishes and the Dr 31/Lud Sa/b bowls, the presence of the potter VERVS, the presence of the small Dr 38 with squared flange, and the large proportion of mortaria all indicate a 3rd-century date. The presence of Lud Vm(g) and Chenet 335 beakers, the bat-like spout on the Dr 45 mortarium, the small Niederbieber 11 dish, as well as the poor-quality decorative arrangements on Dr 37 and the presence of line-stamps (Strichstempel) all indicate that the chronology could be indicative of the middle of that century, but not too much later.

The fabrics and typology of the assemblage show significant parallels to the Trier Massenfund (*c* AD 240–60) and Louis-Linz-Strasse (*c* AD 260–75) complexes, both dated to the middle of the 3rd century or somewhat later (Linz-Strasse). The same fabrics, forms, and pottery workshop (of Julius II–Julianus I) were also attested at the Shadwell watch-tower site, now considered to be established around AD 250 or somewhat later (Bird *in press*). The absence of the late Trier fabric and typical forms dominating the ‘post-Niederbieber-horizon’ (AD 260–300) such as the Niederbieber 6, 18, and 19 (Reuter 2005, 231) suggest that a date after AD 260 for the OS 4980 samian ware group would be too late. These elements suggest that a *terminus post quem* for the deposition of the samian

group in context OS 4980 must be around the middle of the 3rd century (*c* AD 240–60).

Apparently both of the dominant 3rd-century production-centres are supplying their products to Oudenburg in equal quantities, although there is a bias towards mortaria and dishes in TRI SA fabric, while plain bowls (deep dishes) and beakers most commonly occur in RHZ SA. The Argonne and North-Gaulish workshops supplied their products only on a moderate scale. The presence of Lezoux samian compared to the mass of East-Gaulish material however, is more difficult to assess. Apart from a residual Dr 18/31 sherd, the presence of a complete Dr 38 was surprising. The intense use-marks and the absence of a bead-rim suggest that this was a relatively late product of the Lezoux workshop (late 2nd to early 3rd century) and that it had survived in use for several decades.

This Trier and Rheinzabern domination of the supply of samian in equal proportions to northern Flanders contrasts with the pattern observed for the late 2nd and first half of the 3rd century (De Clercq and Deschietter 2002). During this earlier period, Rheinzabern products dominated samian supply to the area close to the sea and the Scheldt-mouth. Presumably, merchants in Rheinzabern samian were based in the Scheldt-estuary for trade in samian locally and for supply to Britain. Other production centres such as Argonne, Trier and Lezoux (where production had ceased by AD 200) were at that time all supplying in moderate quantities. When comparing this late 2nd and first half of the 3rd century pattern to the OS 4980 group of mid-3rd-century date, it seems that towards the middle of the 3rd century, the market share of the Trier workshops has grown considerably to equal that of the Rheinzabern industry.

Colour-coated and black-slipped wares

The group of colour-coated and black-slipped wares is represented by 31 sherds (15 MNI), in four fabrics: Cologne colour-coated ware, Moselkeramik black-slipped ware, Lower Nene Valley colour-coated ware and New Forest colour-coated ware; another 5 MNI have unidentified fabrics (Fig 9). All, except one sherd from a bowl, are beakers.

Fabrics

COL CC: Cologne colour-coated ware represented by 1 sherd from the rim of a Niederbieber 32c beaker (Oelmann 1914) (Fig 9, no 1). This sherd is residual. Unlike the other sherds in this group, it has a strongly weathered surface.

MOS BS: Trier black-slipped ware; 13 sherds, MNI 4, all in a red fabric with grey core or margins, in a sandwich of thin, well defined layers (Col Pl 2, b). The

later Trier fabric (of *c* AD 275 to the 4th century), which has a coarser texture than the 3rd century fabric and displays no 'sandwich-effect', is not present in the assemblage. All of these sherds are of beaker form Niederbieber 33, Symonds, Trier form 1 (1992, 49) (Fig 9, no 2). One specimen is a motto beaker (Fig 9, no 3; Fig 10), with decoration in two zones divided by horizontal rows of barbotine drops and horizontal rouletting. The upper zone has part of a motto:]VEA[. It has not proved possible to expand the motto. The lower zone contains floral barbotine scrolls. Stylistically it belongs to Gruppe II of Künzl (1997). This type of beaker is manufactured *c* AD 260–70 (Künzl 1997, 59). The form is also present as a rim sherd, a wall sherd with barbotine decoration (Fig 9, no 4) and another with indentations (Niederbieber 33c).

LNV CC: Lower Nene Valley fabric; 11 sherds, MNI 4, all but one in a white, yellowish-white, or pale orange-brown fabric slipped with a brown or black, dull, slight shining or metallic coating. A large sherd of a beaker with a black, dull coating and a lattice decoration in white paint or barbotine, above a rouletted band, is probably also from the Nene Valley kilns (Fig 9, no 5; Fig 11) (Dr Malcolm Lyne *pers comm*). The fabric has a pale grey core and orange-yellow margins (Col Pl 2, c). One rim sherd belongs to a Niederbieber 33 beaker. A second is represented by a wall sherd of a beaker or flagon, decorated with diagonal lines of barbotine, separated by bands of rouletting (Fig 9, no 6), and a third vessel by an undecorated body sherd. Finally, there are 8 body sherds of a beaker with a red-brown interior, a flamed bluish-grey metallic exterior and three rows of rouletting (Fig 9, no 7).

NFO CC: New Forest colour coated; MNI 1, one base of a beaker with dull black coating has a pale grey fabric, to be identified as fabric Fulford (1975) 2b from the New Forest kilns (Dr M Lyne *pers comm*).

UND: 5 MNI could not be attributed to pottery production centres; 4 are represented by sherds from colour-coated and/or black-slipped beakers. A 5th, a sherd from the collar of a collared bowl, imitating a Dr 38 form, has an off-white fabric rich in mica with an orange brown, slightly shining coating.

Discussion

Except for the unidentified collared bowl sherd, the colour-coated and black-slipped sherds are all from beakers. Only a small number of vessels are represented, although beakers in other wares are well-represented (*see Fine Reduced Wares below*). The variety of Romano-British imports provides evidence of a potential small-scale trade of Romano-British pottery to the continent in the later 3rd century AD, although they

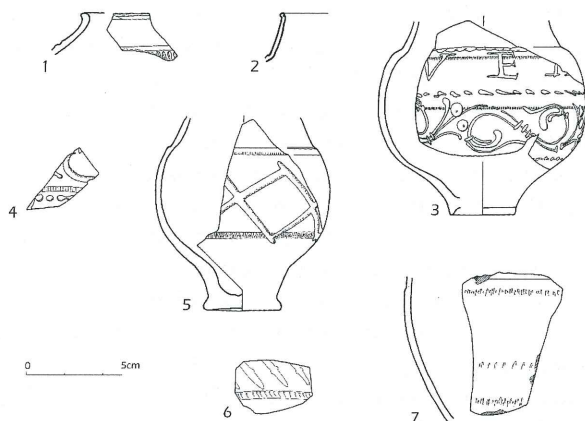

Fig 9: Colour-coated (nos 1, 5–7) and black-slipped (nos 2–4) wares, scale 1:4



Fig 10: MOS BS motto beaker (Fig 9, no 3) (photo: copyright VIOE), scale marked in cm

could also represent the personal property of individuals rather than direct evidence for trade.

This group of colour-coated and black-slipped wares provides important evidence for the date of deposition of the assemblage. The Gruppe II motto-beaker (Fig 9 no 3, Fig 10) dates the filling of the pit after *c* AD 260, which is somewhat later than the dating provided by the samian. The presence of a New Forest product also places the deposition of the assemblage after *c* AD 260 (Tyers 1999, 173).

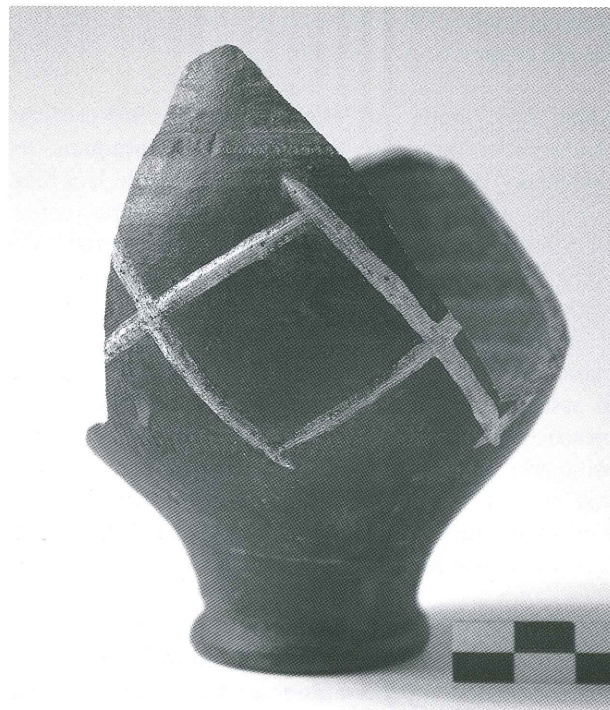

Fig 11: LNV CC beaker (Fig 9, no 5) (photo: copyright VIOE), scale marked in cm

Terra rubra

Terra rubra is a Belgic ware produced from the reign of Augustus until around AD 70 in imitation of forms found in Italian samian and pre-Roman Gaulish earthenware. A wall sherd of a beaker found in OS 4980 must therefore be residual. It has a rouletted band, groups of four vertical lines and a horizontal undecorated band, enclosed by two broad grooves. On the exterior the sherd is orange-brown, the interior grey. The composition of the fabric points to a North Gaulish origin. It probably belongs to a 'Gurtbecher' (Deru 1996, Type P29.2) (*not illustrated*).

Fine oxidised ware

This group is represented by a wall sherd of a 'planetary vase' (Fig 12). These seem to have been manufactured for use in house-shrines or *lararia* for private domestic worship and as offering vessels in sanctuaries. There are two groups, the most common with 3, 4, 6, or 7 busts of divinities, mould-made, then added to the body of the pot. Details like hair, beard and clothing, were added using modelling sticks, prickers, knives, stamps and pastilles (Amand 1984; Brulet and Vilvorder 2004, 11–16). A body sherd found in OS 4980 is an example of the second, less common group, with a standing Mercury with his attributes. This sherd has a soapy pale-yellowish fabric, containing rare fine black inclusions and small voids. The sherd shows part of the head of a male divinity. He is beardless with hair of spiral curls, made

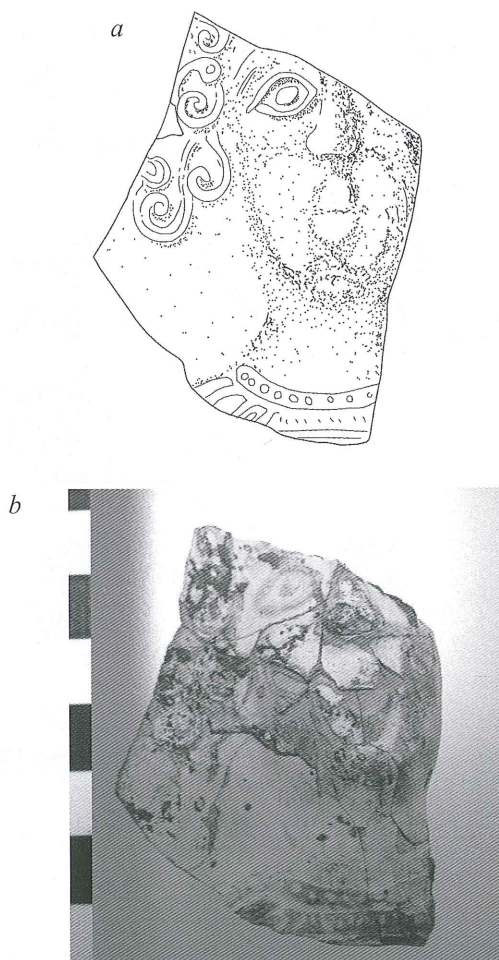

Fig 12: a) drawing and b) photograph (scale marked in cm) of a sherd from a 'planetary vase' (photo: copyright VIOE)

with a stamp. The collar and the sleeves of the cloak are delicately made with a pricker and a modelling stick. The fabric and style show that it comes from the region of Bavay, which is the main production centre for these vessels. Little is known of the chronology of this pottery, which occurs at occupation sites during the 2nd and 3rd century AD (Brulet and Vilvorder 2004, 15). This body sherd could belong to a vessel that was still in use in the later 3rd century or it may be residual.

Fine reduced ware

This group of fine reduced ware has finer fabrics and better finished exterior walls than the coarse reduced ware groups (Fig 13, nos 1–14). It is well represented in the OS 4980 pottery assemblage with 287 sherds or 5% of the total sherd count, 27 by MNI or 3.65% of the MNI total. After the samian this is the best represented group of fine ware. Three fabrics can be distinguished: the North Menapian fine reduced ware (NOM FR), the North Gaulish fine reduced ware (NOG FR) and the Low

Lands Ware (LLW1). The North Menapian fine reduced ware fabric represents 95% of the sherds or 81% of the MNI in this pottery group.

Fabric

NOM FR: Grey hard fabric with an irregular fracture. Sometimes with a pale grey core and well sorted inclusions. Fine quartz grains dominate, either in moderate or abundant quantities, with sparse feldspar and glauconite also present (Col Pl 2, d).

Typology

All these vessels, with the exception of one jar, are beakers. The exterior surfaces are usually completely burnished with vertical or horizontal lines. The beakers recall older thin-walled forms in North-Gaulish terra nigra (types Deru 1996, P46–53 and especially the 3rd century type P53). The following types are present in the OS 4980 pottery-assemblage:

Type 1: Globular beaker with tall upright neck and weak everted rim, 12 of the 18 MNI make this the best represented form (Fig 13, nos 1–4; Fig 14). The neck is burnished with horizontal bands; the body is almost completely covered with vertical burnished lines, both systematically applied. This feature is common, but not ubiquitous on the same type of beakers in the previous period. This form was very popular in the Coastal Plain during the 2nd and 3rd century AD (Thoen 1978, TN Type 6 and LOK Type 8). It was used as tableware, probably to serve liquids. A similar type is known in the North Menapian handmade pottery (NOM HA, Type 2).

Type 2: Upright straight-sided neck, a variant type represented by one vessel with completely burnished exterior wall (Fig 13, no 8).

Type 3: Globular beaker with tall neck, and weak everted rim, decorated with studs (Fig 13, no 6; Fig 15). In Dutch called a 'knobbelpot' (Thoen 1978) or 'stud-beaker'. Usually three or four studs or bosses were applied to the shoulder after the vessel was turned. The band between the studs is decorated with a burnished lattice decoration or with simple burnished diagonal lines. The studs were probably applied to the pot to improve the grip. Two vessels occur in the OS 4980 assemblage. One (Fig 13, no 6; Fig 15) is a nearly complete specimen with four studs evenly placed, and with diagonal burnished lines between them; another wall sherd (Fig 13, no 9) has a band with burnished lattice decoration and the top of a frieze with diagonal burnished lines (*cf* NOM HA Fig 23, no 13 and Fig 25 below).

The type apparently emerged during the second half of the 2nd century in the Coastal Plain. Around the turn of the century it was one of the most popular types in

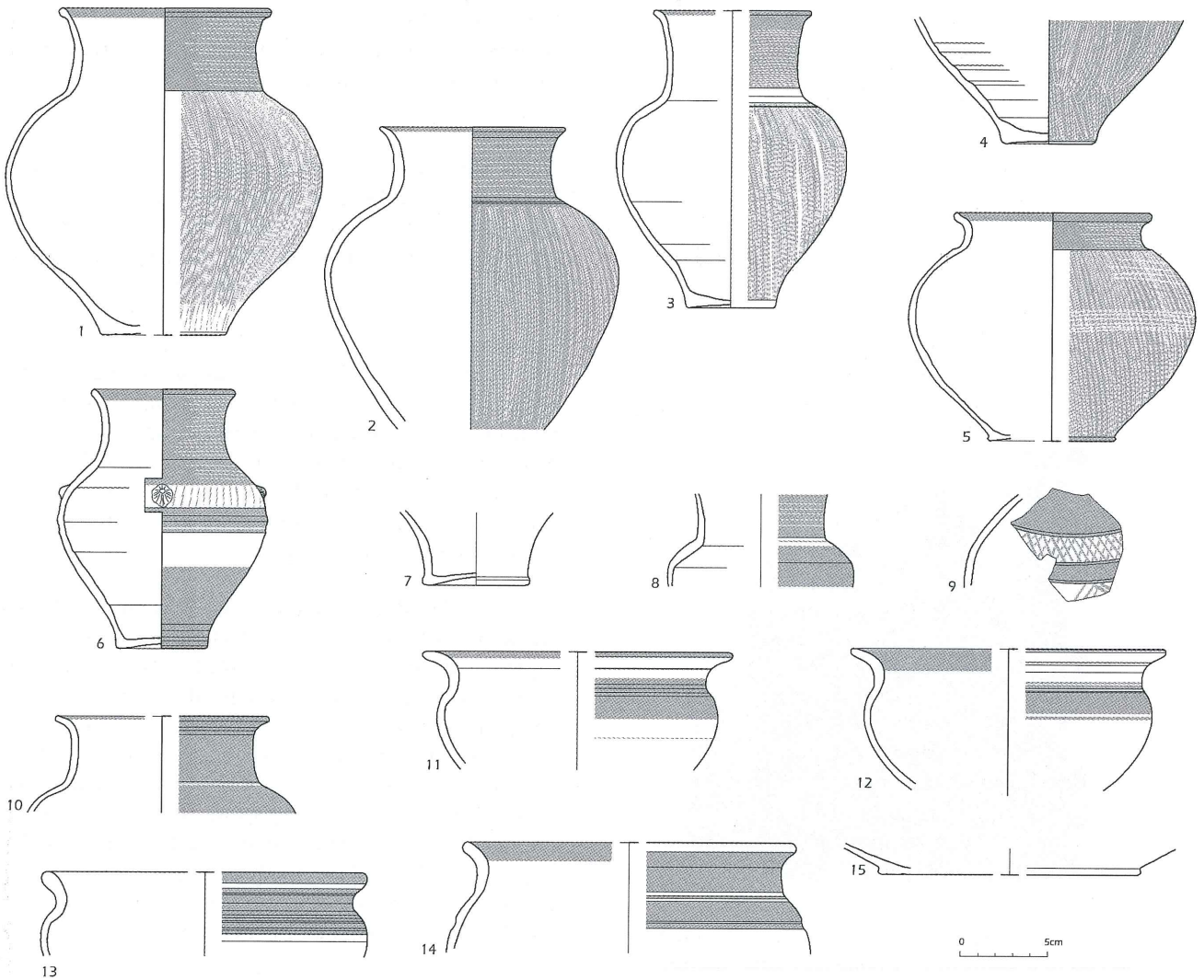

Fig 13: Fine reduced ware (nos 1–14) and base of a Pompeian red ware dish (no 15). Light grey indicates burnished areas, scale 1:4

Coastal Ware (Thoen 1978, LOK Type 9). It is unclear if this type was influenced by other pottery traditions or if it was an innovation introduced by the potters. However it shares the same morphology as Type 1 and the studs are functional as well as decorative. This beaker is such a distinctive type that it is the guide fossil *par excellence* of the North Menapian ware. The beakers were probably used for drinking and serving liquids.

Type 4: Globular jar with short neck and everted rim, shoulder and body follow the same burnished decorative pattern as Type 1, represented by 1 MNI (Fig 13, no 5).

Unclassified: Some base sherds display a high foot (Fig 13, no 7), a common feature in the Coastal Plain and Sandy Flanders wares during the 3rd century AD. A single rim sherd represents a small jar with rounded everted rim and a single body sherd has rouletted bands.

Discussion

This ware probably originates from the same production regions as the North Menapian coarse reduced ware (NOM RE) and the NOM handmade ware (NOM HA). It is found in the area between the mouth of the Scheldt in the north, Oudenburg in the west and the northern part of Sandy Flanders to the south and east. This area corresponds with the northern part of the *civitas Menapiorum*. The North Menapian fine reduced ware and its coarse variant are also known as ‘Coastal Ware’ (Thoen 1978) or ‘Flemish-Roman Ware’ (Trimpe Burger 1997). ‘Coastal Ware’ also includes a handmade component. However the term ‘Coastal Ware’ no longer seems appropriate. New petrological research by W De Clercq and P Degryse of the Catholic University of Leuven, shows that this pottery was probably not manufactured in the Coastal Plain itself as the name suggests, but in Sandy Flanders or at least by potters using tertiary clays



Fig 14: NOM FR beaker Type 1 (Fig 13, no 1) (photo: copyright VIOE), scale marked in cm

originating from that region. Further petrological and chemical analysis is being carried out to obtain more precise data, but the sparse presence of glauconitic grains in the North Menapian reduced ware, is also found in wasters of medieval pottery from kilns near these tertiary outcrops, which seems to support this idea.

This new petrological information, and the distribution pattern reaching to the inland territories south of Bruges, suggested that 'North-Menapian' (NOM Reduced, Fine reduced, Handmade) ware was a more appropriate name and it has been used here. The typology of the pottery group is rooted in the native repertoire, but also includes new forms and decorative patterns some of which show strong influences from the Romano-British Black Burnished ware industry. The NOM industry emerged during the second half of the 2nd century, became mature at the turn of the century and persisted until the second half of the 3rd century.

North Gaulish Fine Reduced

NOG FR: A pale-grey, very fine and very hard fabric with a fused appearance, a regular fracture, dark grey surfaces and an outer surface delicately polished black, very fine quartz inclusions and sparse white mica and iron-rich grains.

Typology

A rim sherd and two wall sherds of a globular beaker with tall straight-sided vertical neck and everted rim occur (Fig 13, no 10).

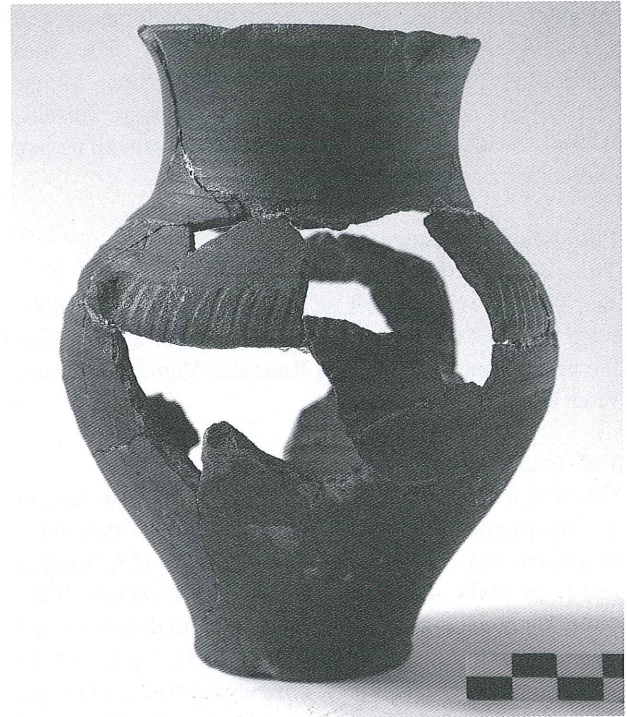

Fig 15: NOM FR 'stud-beaker' Type 3 (Fig 13, no 6) (photo: copyright VIOE), scale marked in cm

Discussion

The very fine quartz, sparse white mica and iron-rich grains inclusions point to an origin in North Gaul.

Low Lands Ware Fabric

LLW 1: this fabric has a mineral content of up to 80% with two quartz populations (one with rounded grains, between 250 and 500µm in diameter and one with angular to sub-angular grains up to 100µm in diameter); opaque minerals and mica are evenly distributed throughout the material. Sporadically, sandstone fragments, temper of crushed ceramics and organic material can be observed.

Typology

In the OS 4980 group, this fabric was petrographically recognised in the flagon-group (*see below*), in a container of the Holw 142 type (*see below*) and in a series of high quality bowls or dishes, closely resembling the late-Roman Chenet (1941) 342 type (*cf* Pirling 1974, 42–43, type 252) or a prototype of it (Fig 13, nos 11–14). Similar forms in the same fabric are found in contexts dated in the period AD 250–300 in Breda (Van Enckevoort 2004, type Vt 76–77).

Discussion

The Low Lands Ware 1 fabric is a recently recognised fabric (De Clercq and Degryse 2008) produced at one or more major pottery production sites probably situated on

the river Scheldt escarpment, near the Scheldt estuary in the Bergen-op-Zoom area (Netherlands). The core distribution of this ware covers the lower Rhine, Meuse and Scheldt valleys. Types include tableware (dishes, flagons, beakers), fine wares (terra nigra) as well as jars and containers (Holw 139–42 type series).

Pompeian red ware

Three sherds of Pompeian red ware (0.05% of the total sherd count) with a MNI of 2 (0.27% of the total MNI) were found. A rim and two base sherds were attributed to the production centre of Les Rues-des-Vignes (Northern France).

Fabric and typology

IMP PR 6: A fabric with grey core and abundant temper of fine quartz, corresponding with fabric 6 of Peacock's Pompeian red ware classification (1977b, 155; Tomber and Dore 1998, 45) and with group RdVA (Deru 2005, 469). The two base sherds seem to be from dishes of type Blicquy 5 (De Laet and Thoen 1969, 33). Fig 13, no 15 shows a pale orange slip on the inner surface, while the other base has a white slip. A worn rim of a Blicquy 5 dish is probably residual.

Flagons

A classification using 'flagon tableware' (FL TW) and 'flagon storage ware' (FL SW) has been used based on the size of the vessel, the thickness of the wall, the coarseness of the fabric and the finish of the exterior surface, to avoid an attempt to define the division between 'flagons' and 'jar-amphoras' based on the number of handles, since in this context tableware flagons can be both one or two-handled.

There are 652 flagon sherds (11.56% of the total sherd count) with a MNI of only 21 (2.84% of the total MNI), a remarkable small number for a Roman context. Only 14 rims, 14 bases and 12 handles can be distinguished (Fig 16). There were joining sherds from 2 almost complete flagons.

Tableware flagons

A large proportion, 278 sherds (42.63% of flagons by sherd count) with a MNI of 15 (71.43% of the flagon's MNI), could be identified as tableware. All except 3 sherds, (275 sherds, 12 MNI) can be attributed to one fabric, originally considered to originate in Northern Gaul, but now identified as a product of the Low Lands Ware 1 pottery industry (LLW1 FL TW) probably originating in the Bergen-op-Zoom area (De Clercq and Degryse 2008).

Fabric

LLW1 FL TW: Rich in quartz, muscovite mica, and with some iron-oxide inclusions (Col Pl 2, e). The fabric

ranges in colour from dark-orange to pale-brown, and from pale-orange to beige. Some of the sherds have a smoked appearance. 10 rims, 6 bases and 8 handles by sherd count in this group are of this fabric.

Typology

There are three different rim profile types:

Constricted rim: Represented by 5 rim sherds (Fig 16, nos 1–3). A two-handled flagon with complete profile (Fig 16, no 1) shows three clear ridges on the shoulder and one ridge on the lower part of the body. A two-handled flagon with almost complete profile (Fig 16, no 3) has the same kind of well defined ridges in addition to other weaker ones.

Ring-shaped rim: A flagon rim, with a ring-shaped rim-profile in a reduced fabric, with two handles (Fig 16, no 4). A sherd of another small flagon with a very fine ring-shaped rim is also present (*not illustrated*).

Everted flattened rim: Two rim sherds, (Fig 16, no 5) one of them has a slightly burned rim and also shows evidence of two handles.

Handles: Single or twofold, each type is represented by 4 examples.

Body: The flagon profiles mentioned above, the lower half of a flagon (Fig 16, no 6) and many body sherds, all have ridges and a polished surface that extends from under the handles to the base of the flagon. Three body sherds have the remains of a white slip covering a red polished surface with ridged surfaces. Another two body sherds were heavily burnt.

A well-preserved black coating was found on the inside of the neck of three flagons, extending from the top of the rim to the transition with the shoulder. On one flagon (Fig 16, no 3) the coating also covers the outside of the rim. It seems to resemble pitch and probably had a function related to preventing evaporation of liquid or to make it easier to pour out liquid contents.

The three sherds in the tableware category not in LLW 1 include a base fragment (Fig 16, no 9) in a soft, soapy, calcareous fabric with mica inclusions, covered with a pale-yellow slip, originating in the region of Bavay in the north of Gaul. The white fabric of another flagon base (Fig 16, no 7) with a few quartz and red iron-oxide inclusions, can be attributed to the Cologne region (KOL FL TW). A narrow base in a pale fabric (Fig 16, no 8) seems to originate from the Meuse Valley (MEV FL TW).

Storage ware flagons

The storage ware flagon category is exclusively made in Low Lands Ware 1 fabric, as are the majority of the

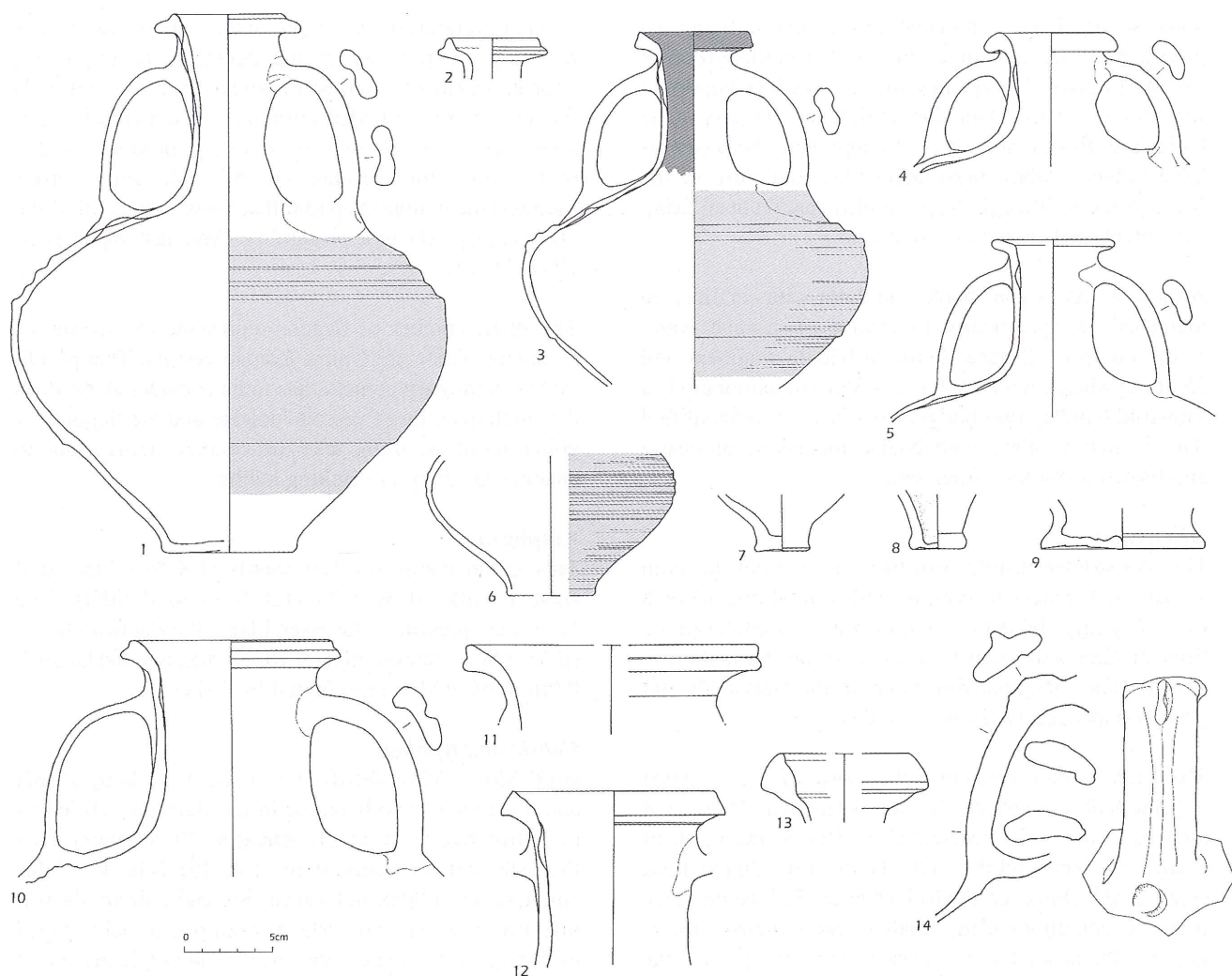

Fig 16: Flagons, light grey indicates burnished areas, dark grey black coated areas, scale 1:4

tableware flagons. 119 sherds (18.25% of flagons by sherd count), 4 by MNI represented by four rims, four bases and three handles were identified as storage-ware vessels.

Fabric

LLW1 FL SW: see LLW1 FL TW

Typology

Two rim profiles can be distinguished:

Constricted rim: This rim profile is the most common, occurring on 3 MNI of two-handled flagons (Fig 16, nos 10–12).

Triangular rim: This profile (Fig 16, no 13) is a North Gaulish imitation of a Dressel 20 amphora.

Handles: On the single handles of 2 storage-ware flagons, there is a 'beaked' projection (*anses à aigrette*, Baudoux *et al* 1998, 27) at the top of the handle (Fig 16,

no 14). The function of this may be only decorative or it may improve grip on the handle. These resemble the projections commonly found on the handles of Gauloise 13 amphoras. Gauloise 13 amphoras were probably produced at Cambrai and Bourlon (North of France) and possibly even further north (Baudoux *et al* 1998, 27, 32, fig 25, 33, fig 26). The illustrated handle with 'beak' (Fig 16, no 14) also has a finger impression at the base of the handle. Another 44 body sherds show the attachment point on the body for a large handle.

Body: Polishing on the body is less common than in the tableware category. The jar (Fig 16, no 10) does show polishing beginning under the handle, but only another six body-sherds (which are also burnt inside) show this fine line-polishing. Two two-handled flagons (Fig 16, nos 10 and 12) have a white slip on the external surface extending into the inside of the rim, and inside the neck in the case of Fig 16, no 12. This slip was probably more common but has not survived in most cases. Three other

body sherds have a reduced fabric and a flame-red polished surface. No ridges are attested in this group of storage flagons. Perhaps appearance was less important for storage ware than for tableware flagons. One tableware flagon and three storage-ware body-sherds have reduced fabric presumably due to failure in the firing process although the possibility that reduced firing was intentional cannot be excluded.

A total of 255 flagon sherds could not with certainty be identified as specifically tableware or storage ware. These comprise 2 base sherds, a handle fragment and 252 body sherds with a MNI of 2. Worth mentioning is a four-fold handle. Two body-sherds have an unidentified but distinctive fabric with coarse inclusions of quartz and brown iron-oxide fragments.

Discussion

The constricted-profile rim-form is present in both storage and tableware groups, with a total overall of 8 rims. The ring-shaped rim and everted, flattened rim are finer profiles and seem to occur only on the tableware vessels. The triangular rim imitating the Dressel 20 rim was probably reserved for storage vessels.

The LLW1 fabric resembles the fabric of the so-called Scheldt Valley amphoras in hand-specimen. These 'red amphoras' are well represented at sites in the north of France, Flanders and the Netherlands of the 2nd and 3rd century AD. However, the lack of mica, and the presence of more equally-divided, smaller and rounded quartz-grains in the Scheldt Valley fabric clearly distinguishes the two products. There are distinctions between the lower Scheldt Valley LLW1 and the former Scheldt-Valley Ware which could well have been produced further upstream in Northern France or in Hainaut (Thuillier 2001). Because of the strong distribution in the Scheldt Valley it was at first thought that these flagons originated there (Van der Werff *et al* 1997, 2–5). However, this distribution may be a reflection of a commercial trade link (De Clercq 1995). At a ceramics workshop at Lille (Université de Lille 3) for the site of Dourges (*cf* Thuillier 2001) fabric analysis has shown that samples of so-called Scheldt Valley flagons of Zele, Seclin, Hénin-Beaumont and Velzeke, and of sherds of so-called Scheldt Valley amphoras from pottery kilns found in Dourges are of a macroscopically identical fabric.

It is uncertain what specific liquid these flagons would have contained. The black coating, of resin or pitch, often found on the interior of sherds and sometimes inside the neck of some Oudenburg flagons may give an indication. It has been suggested that, since oil does not evaporate, the pitch coating excludes the possibility of the flagons being oil containers (Van der Werff *et al* 1997, 11). It is not clear if the pitch coating is meant to

prevent evaporation or if it has another purpose, such as reducing the porosity of the container or improving pouring of (more viscous?) liquids. There are parallels for pitch coating of Mediterranean wine and fish sauce amphoras. Wine seems an unlikely product in this region but the production of fish sauce after Mediterranean imports had fallen away at the end of the 2nd century AD is a possibility (Van der Werff *et al* 1997, 11–15).

The small number of flagons represented is worthy of comment. These are typical Roman vessels. That pit OS 4980 is a military context, has to be considered. Or does the small quantity of vessels indicate that the flagon was going out of use in the later 3rd century, perhaps due to changes in eating or drinking habits?

Amphorae

This group comprises 106 sherds (1.87% of the total sherd count), 10 by MNI (1.35% of total MNI). Two fabrics are present in the assemblage: the Baetican fabric (BAT AM 2), represented by 102 sherds, and the Gaulish fabric GAL AM 1, represented by 4 sherds.

Fabric and typology

BAT AM 2: Most sherds (1 rim sherd, 87 body sherds and 5 sherds of two handles) in the Baetican fabric can be attributed to a single Dressel 20 amphora (*see* Peacock and Williams 1986, 136–40) (Fig 17). This amphora has a thick light-grey core and pale red-brown margins. The external surface is slipped or self-slipped to light-grey. On the exterior wall of the body are traces of painting, with the brushstrokes clearly visible (Dr P Monsieur *pers comm*). One of the sherds has a small repair hole. The stamp on the handle has probably been removed with a hammer or chisel (Dr P Monsieur *pers comm*). A large proportion of the sherds have traces of soot, which became adhered after the amphora was broken. The heavy, stocky profile of the rim is typical for 3rd century Dressel 20 amphorae. Form and fabric indicate a date between AD 190 and 240 (Dr P Monsieur *pers comm*). The handle of a second Dressel 20 is also present. The other 8 sherds in the group of the Baetican fabric are all wall-sherds of Dressel 20 or 23 amphorae (4 MNI). One of these sherds is thinner than the others and has a pale-red fabric with greyish-white surfaces, typical of late Dressel 20 amphorae.

GAL AM 1: The four sherds in Gaulish fabric seem to belong to four different Gauloise 4 wine-amphorae (*see* Laubenheimer 1990, 98–99).

Dolia

Only four sherds of pottery from OS 4980 can be identified as fragments of large storage jars (dolia), 1 by MNI, which represents only 0.07% of the total sherd

count (0.13% of the total MNI). The quartz tempered fabric with dark-grey core can be recognized as a North Gaulish product (NOG DOL). The only rim fragment is

of Gose type 358 (Gose 1950, taf 58) (*not illustrated*). One body fragment is decorated with wheel-stamped bands (Fig 18, no 6).

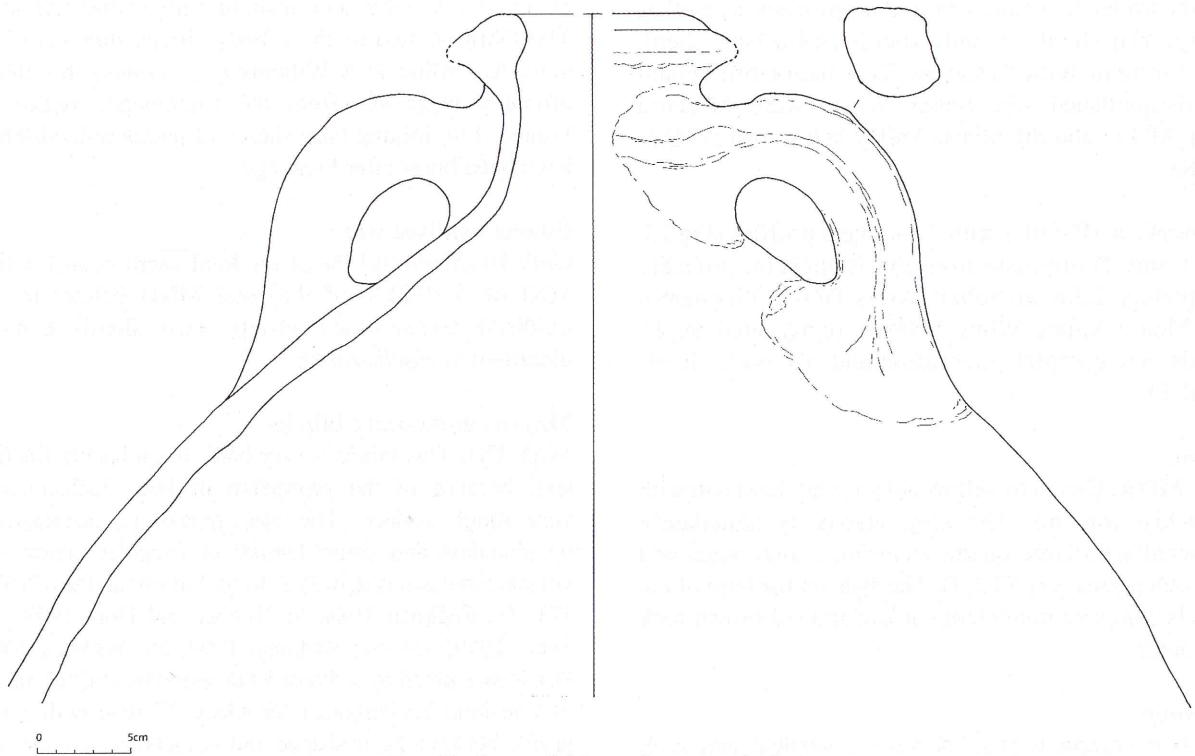

Fig 17: Dressel 20 amphora, scale 1:4

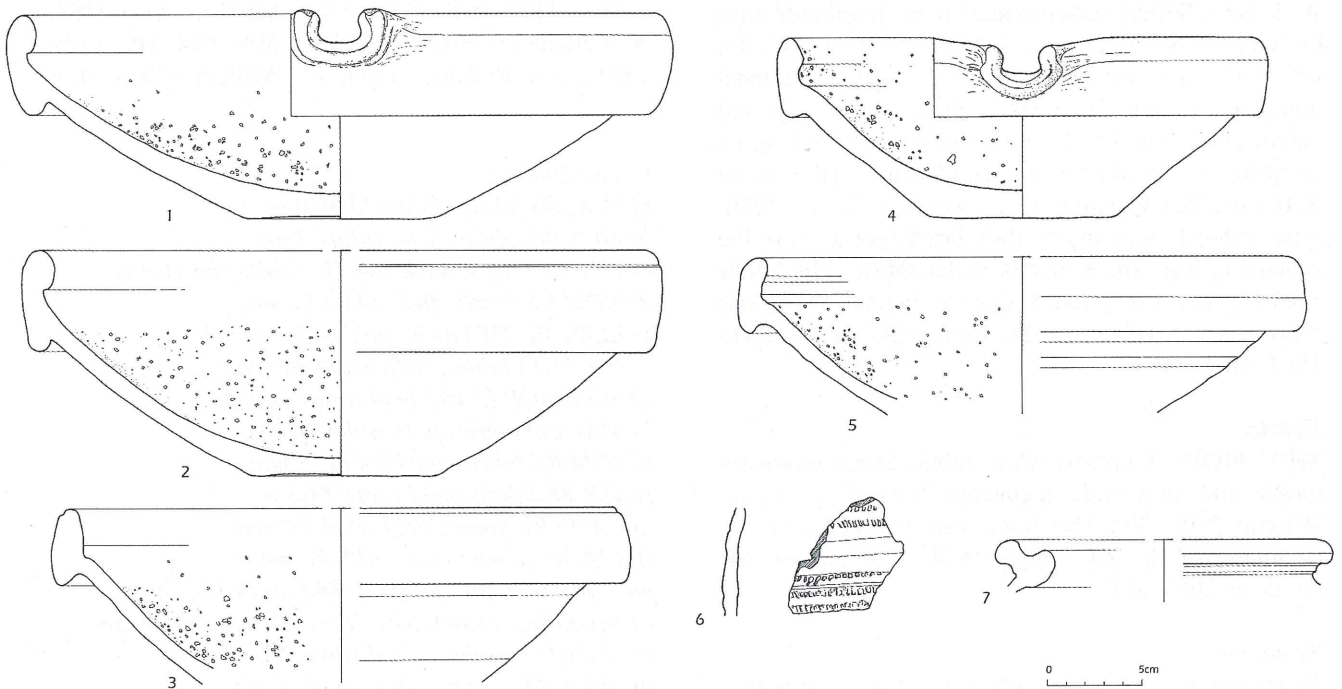

Fig 18: Mortaria (nos 1-5), wall sherd of a dolium (no 6) and rim sherd of a coarse oxidised vessel MAY CO fabric (no 7), scale 1:4

Mortaria

The mortaria group is represented by 44 sherds (0.78% of the total sherd count) and a MNI of 7 (0.94% of the total MNI) (Fig 18, nos 1–5). Checking for joining sherds produced 3 complete pottery profiles, as well as 2 large rim sherds, 5 body sherds and a base sherd. There were no potter's stamps. Two main fabrics could be distinguished: the Soller White Ware Mortaria (SOL MOR) and the Meuse Valley White Ware (MEV MOR).

20 sherds, a MNI of 3 with 2 complete profiles (Fig 18, nos 1 and 2) originate from the Rhineland, probably the pottery kilns at Soller (Kreis Düren, Germany), and Meuse Valley White Ware is represented by 17 sherds: one complete mortarium and two body sherds (MNI 1).

Fabric

SOL MOR: Cream to yellow colour, very hard and with a hackly fracture. The clay matrix is abundantly tempered with large quartz inclusions, some mica and iron-rich grains (Col Pl 2, f). The grits on the base of the vessels comprise rather large quartz and red-brown rock fragments.

Typology

The two complete profiles have a vertical rim with hammer-shaped profile (Van Vinckenroye 1991, 337; Gose 1950, 451–53), a rim type revived in the middle of the 2nd century AD (also the start of production at the kilns at Soller) and continued to be distributed until the end of the 3rd century AD (Haupt 1984, 444–45, taf 183). One mortaria (Fig 18, no 1) is almost complete, except for a small piece of the rim and spout. The other (Fig 18, no 2) has sherds making up $\frac{2}{3}$ of the mortarium rim. The rim fragment (Fig 18, no 3) of type Van Vinckenroye (1991), 337, Gose (1950), type 451–53, was burnt after breakage, as was the remaining base sherd of this Soller fabric. The Soller rims Fig 18, nos 2 and 3 show a distinct and a less clear groove, typical for this form at Soller (*cf* Haupt 1984, taf 183).

Fabric

MEV MOR: A creamy-white fabric characterised by quartz and iron-oxide inclusions (Col Pl 2, g) (*cf* Willems 2005, 30). This fabric can be dated from the beginning of the 1st century to the 3rd century AD (Willems 2005, 32).

Typology

Rim type Van Vinckenroye (1991), 337, Gose (1950), type 451–53 dates Fig 18, no 4 to the late phase of this fabric's distribution. The vessel has grit spreading to the top of the rim and has some finger impressions on the base.

Unclassified: The Van Vinckenroye (1991), 337, Gose (1950), 451–53 type is also represented by a rim fragment that can not be attributed to either the Soller or the Meuse Valley group due to secondary burning (Fig 18, no 5). Five other mortar sherds remain undetermined. The fabric of two of these body sherds shows a black core. According to S Willems (*pers comm*) this fabric probably originates from the Champagne region of France. Two joining base sherds of undetermined fabric have been burnt after breakage.

Coarse oxidised ware

Only 10 sherds (0.17% of the total sherd count) with a MNI of 6 (0.81% of the total MNI) belong to the oxidised coarse ware group. Two sherds can be identified as *Eifelkeramik*.

Mayen coarse-ware fabric

MAY CO: This fabric is very hard, has a hackly fracture and, because of the protrusion of large inclusions, a very rough surface. The clay matrix is characterised by abundant and dense temper of irregular quartz and volcanic inclusions (Col Pl 2, h) (*cf* Fulford and Bird 1975, 171–73; Redknap 1988, 5; Tomber and Dore 1998, 70; Tyers 1999, 151–52; Redknap 1999, 58; Willems 2005, 90). Represented by a rim of a lid-seated jar (Fig 18, no 7), of transition Niederbieber 89-Alzey 27 type with a rim profile between heart-shaped and sickle-shaped (Oelmann 1914, taf 3; Unverzagt 1968, taf 2). Niederbieber 89-Alzey 27 is an early product of the Mayen industry and so far can only be generally dated from the end of the 3rd century to the middle of the 5th century AD (Unverzagt 1968, 34; Fulford and Bird 1975, 179; Gilles 1994, 119; Tyers 1999, 152; Redknap 1999, 61; Willems 2005, 91).

Colour Plate 2:

- a) NOG SA fabric; field width 20 mm;
- b) MOS BS fabric; field width 13 mm;
- c) LNV CC Fig 9, no 5; Fig 11; field width 10 mm;
- d) NOM FR fabric; field width 13 mm;
- e) LLW1 FL TW fabric; field width 17 mm;
- f) SOL MOR fabric; field width 20 mm;
- g) MEV MOR fabric; field width 20 mm;
- h) MAY CO fabric; field width 20 mm;
- i) NOM RE fabric; field width 13 mm;
- j) ATR RE fabric; field width 13 mm;
- k) CALO RE fabric; field width 20 mm;
- l) ARD RE fabric; field width 17 mm;
- m) Colchester BB2 fabric?; field width 15 mm;
- n) South-East Dorset BB1 fabric; field width 17 mm;
- o) NOM HA 1 fabric; field width 20 mm;
- p) NOM HA 2 fabric; field width 15 mm;
- q) NOM HA 3 fabric; field width 20 mm;
- r) NOM HA 3 Fig 31, no 4; field width 13 mm
(photos: Ghent University)

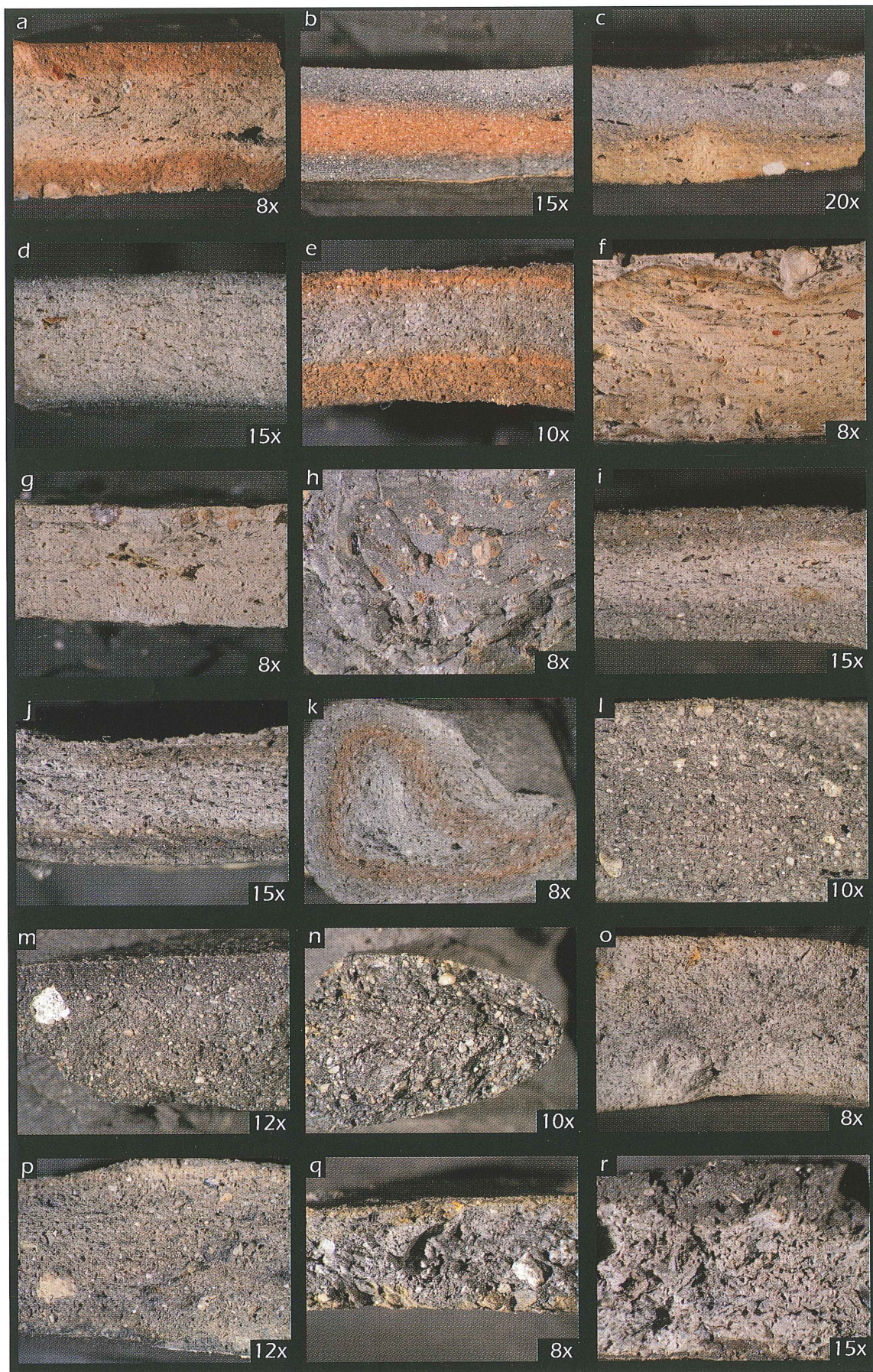

Colour Plate 2

According to Stamm (1962, 103) however, the first phase of the Alzey 27 type has a broader date range from the 2nd half of the 3rd century AD onwards.

URM CO: One base fragment originates from Urmitz. This finer fabric shows smaller quartz and rock fragment inclusions in a layered structure (Gilles 1994, 117; Willems 2005, 88). Production at Urmitz took place between *c* AD 190 and 260 at the latest (*ibid*, 88).

RME CO: A body fragment which can only be more generally assigned to the Rhine-Meuse-Eifel region. Seven sherds of oxidised coarse ware with a MNI of 3 could not be identified with certainty. Two rims are sherds of bowls with incurved rim.

Coarse reduced ware

Coarse reduced ware is the largest group in the OS 4980 assemblage apart from the handmade pottery (*below*). It comprises 33 % of the sherds, 35% of the total MNI (Figs 19–24). The 7 different fabrics identified are discussed in detail below:

North Menapian coarse reduced ware

This fabric dominates the coarse reduced ware representing 96% of the sherds, 89% of the MNI. North Menapian reduced wares, both the fine wheel-thrown version (*above*) and its handmade equivalent, were previously called 'Coastal Ware'.

Fabric

NOM RE: 233 MNI, hard fabric with a slightly irregular fracture. Mostly the fabric is grey, sometimes it has a pale-grey core with brown margins and grey surfaces. Well-sorted fine-sized opaque to near-opaque and rounded quartz, present in moderate to abundant quantities, dominate. Other inclusions are black grog, organic matter and sparse feldspar. Occasionally fine rounded glauconitic grains occur (Col Pl 2, i). NOM RE displays the same fabric as NOM FR (*above*), but with a coarser tempering and with the additional use of clay-pellets.

Typology

NOM RE has been divided into 19 form types. Apart from some beakers (Types 1 and 2) and some possible dishes (Type 11), the forms in this fabric are mainly bowls (Types 3–14), jars (Type 16) and lids (Types 17–19).

Type 1: Beaker with upright rim. Represented by 2 rim sherds of 2 vessels of which one is illustrated (Fig 19, no 1); both have burnished exterior walls, possibly imitating a 3rd century black-slipped or colour-coated beaker form.

Type 2: Globular beaker with a tall conical neck (*not illustrated*). Three wall sherds, 1 MNI from a beaker

decorated on shoulder and body with rouletted bands, delimited with horizontal burnished lines or grooves. A well-known type in the Coastal Ware tradition (Thoen 1978, LOK type 10) which seems to be influenced by the Niederbieber 33a and/or the North French pottery tradition.

Type 3: In-curving-walled bowl with plain rim.

Represented by 27 NMI, most common type after everted rim jars, in the NOM RE fabric (Fig 19, nos 2 and 3). Three vessels have an angular shoulder (Fig 19, no 3). At least ten vessels are burnished from the top to 20–30mm below the rim. This probably decorative burnished zone is usually delimited by one or two grooves. The interior is not burnished. The form, with a similar style of burnishing and grooving, also occurs in the handmade pottery group (NOM HA: type 6; Fig 27 nos 10–12 *below*). This type with angular shoulder is well-known in the Coastal Ware tradition and has a date range from the end of the 2nd century to the first half of the 3rd (Thoen 1978, LOK type 4a and 4b). One vessel has a stud or boss 20mm below the rim, with the top of the rim above the stud burnished. Soot on the exterior and in some cases the interior indicates that this vessel-form was used for cooking.

Type 4: In-curving-walled bowl with flat rim:

some examples of this bowl type have a broad shallow groove just below the rim on the exterior (Fig 19, nos 6 and 7). The interior of 3 vessels is decorated with burnished zones in a radial pattern (Fig 19, nos 6 and 8). Most vessels also have burnished horizontal lines on the upper part of the exterior, and Fig 19, no 6 also has vertical burnishing externally, another vessel (Fig 19, no 7) is entirely burnished on the interior.

Although the form is well-known in the Coastal Ware tradition from the end of the 2nd century to the first half of the 3rd, the decorative scheme is not. Apart from those from Oudenburg, this type of bowl with radial burnishing has only been found at the fortified settlement of Aardenburg (Dhaeze *in prep*).

Type 5: In-curving-walled bowl with flat rim and exterior cordons.

Only one example of this vessel (Fig 19, no 4) is present. It probably belongs to the same tradition as Type 3. The cordons over the exterior are burnished. The type is also well-known in the Coastal Ware tradition from the end of the 2nd century to the first half of the 3rd (Thoen 1978, LOK type 4c).

Type 6: In-curving-walled bowl with lid-seated rim.

Represented by 3 rim sherds of 3 (MNI) vessels (Fig 19, no 10), it has burnishing on the upper part of the exterior.

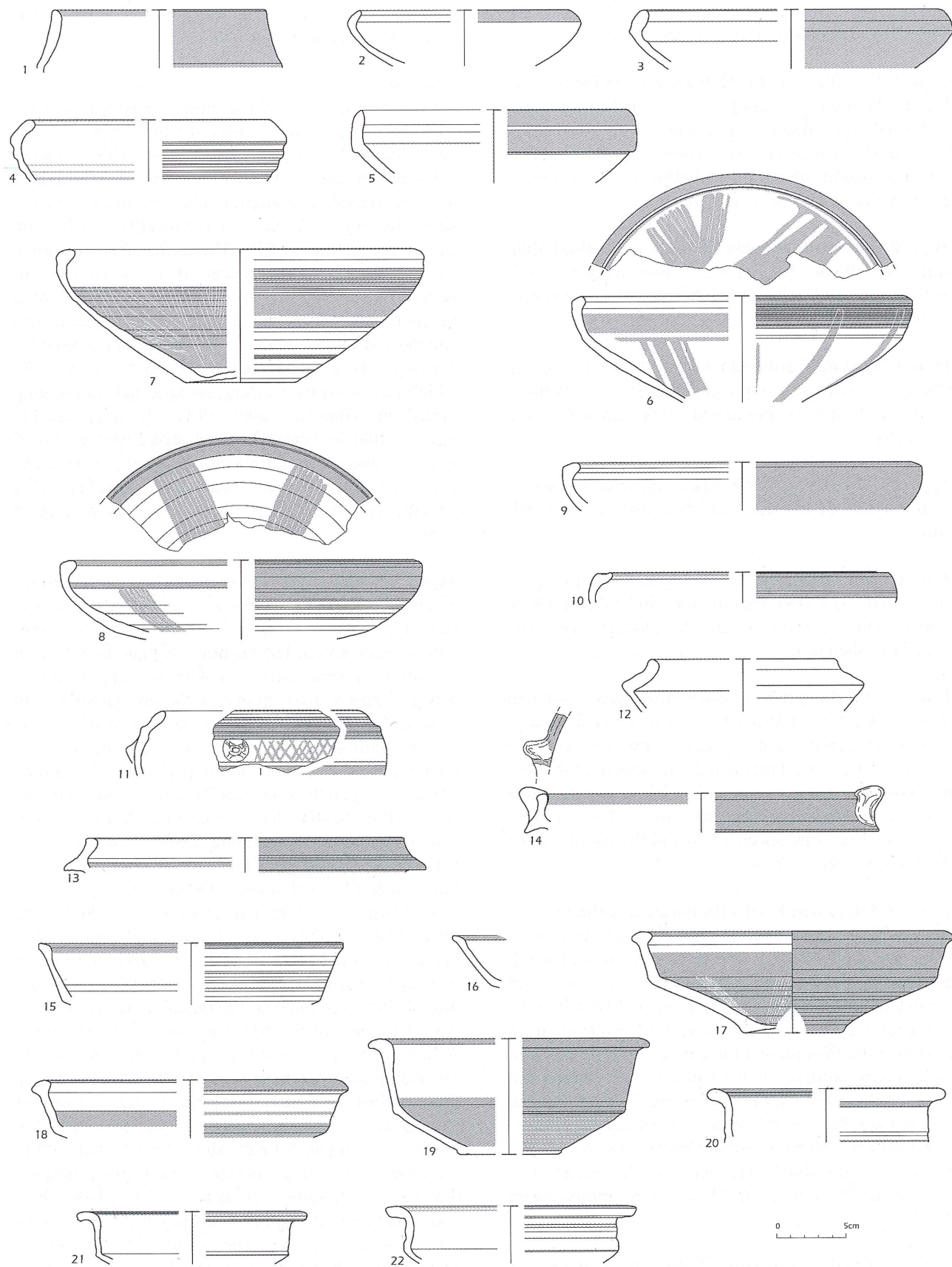

Fig 19: NOM RE beakers, bowls and dishes, light grey indicates burnished areas, scale 1:4

Unlike most of the other bowl types in the NOM RE fabric, this form could be closed with a lid.

Type 7: Globular bowl with plain rim and studs (Fig 19, no 11), a unique vessel with a burnished rim and a burnished lattice decoration in between studs or bosses. Studs and burnished lattice or diagonal line decoration is a typical feature of the Coastal Ware tradition, mostly occurring on stud-beakers (*see above*).

Type 8: Bowl with angular shoulder and raised plain rim (Fig 19, no 12), another vessel unique in this assemblage, with soot on both internal and external surfaces.

Type 9: Bowl with collared rim (Fig 19, nos 13 and 14). One of the two vessels present (Fig 19, no 14) has a small stud and is burnished both internally and externally.

Type 10: Bowl with wall-sided rim (Fig 19, no 5), with exterior of the rim burnished, and exterior wall burnt.

Type 11: Bowl/dish with flat rim and chamfer (Fig 19, nos 15 and 16) 3 MNI, the only form in NOM RE fabric which could have been used as dish or platter. One vessel has a burnished rim.

Type 12: Carinated bowl with thickened bead rim (Fig 19, nos 17 and 18), 7 MNI. A type not present in Coastal Ware products at its peak of distribution between the end of the 2nd century and the beginning of the 3rd. It is possible, based on material from Aardenburg, that this type belongs to a later phase of the Coastal Ware tradition which only appeared around the middle of the 3rd century (Dhaeze *in prep*).

Type 13: Carinated bowl with horizontal rim (Fig 19, nos 19–22), 7 MNI, another type-fossil of the Coastal Ware production (Thoen 1978, LOK Type 6a and 6b). It emerged around the third quarter of the 2nd century, and became popular around *c* AD 200 and the first half of the 3rd century. The vessels from OS 4980 seem to constitute the final phase of this type. They are not such high quality products as their predecessors which had flat or reeded rims. The OS 4980 examples have rounded rims without the typical burnished wavy-line decoration. Burnishing is very rare on these bowls. One vessel (Fig 19, no 19) has slight burnishing on the interior and exterior, another vessel (Fig 19, no 21) has burnishing on the rim.

Type 14: Bowl with carinated shoulder and hooked rim (*not illustrated*). A type of bowl known as North French 'bol caréné' (*see* Tuffreau-Libre 1980, 51 ff).

One of the main types of pottery produced at Artois and in neighbouring areas (*see below*).

Discussion

Approximately 30% of the North Menapian reduced ware vessels are bowls. The two main types are in-curved-walled and carinated bowls, with globular, collared-rim and wall-sided bowl-types represented only by individual examples. The majority of vessels, approximately 64%, are in-curved-walled bowls, with Type 3 accounting for 44%. The carinated bowls form *c* 24%. Only a small percentage of the bowls had lid-seated rims (Type 6). It is not always clear what function these bowls had. Vessels with lid-seated rims and those with soot on the walls were probably used for cooking. The carinated bowls are similar to *caccabi*, which were used for roasting, cooking and warming-up ingredients (Batigne Vallet 2001, 38). It is unlikely however that the Oudenburg carinated bowls were used like this since they did not display soot patterns. The decorated bowls, such as those with a burnished radial pattern, were more likely to have been used to serve food.

Type 15: Globular jar with everted rim, often described as a cooking-pot (Fig 20, nos 1–10 and 14–16). The type comprises half of the vessels in the North Menapian reduced ware group. The majority are plain-rimmed (Fig 20, nos 1–7), some have a hooked rim (Fig 20, no 8); others display a small groove on the rim, possibly a lid seating (Fig 20, nos 9–10). The interior of the rim, is usually burnished, sometimes also the rim exterior, although this is usually accompanied by burnishing elsewhere, eg on the neck (Fig 20, nos 1, 3 and 7) on the upper part of the shoulder, or on the lower half of the neck and the upper part of the shoulder (Fig 20, nos 5 and 6). Handmade cooking-pots found at the nearby site of Plassendale III (Zandvoorde – Ostend) display the same type of burnishing (Vanhoutte and De Clercq 2007). The lower body of these jars is usually decorated with horizontal scored combing (Fig 20, nos 1 and 9), but vertical or diagonal scored combing also occurs (Fig 20, nos 14–16). This combed decoration is one of the most typical features of the NOM RE and NOM HA ware. A large proportion of the handmade cooking-pots in the OS 4980 pottery assemblage and at Plassendale III have this combed decoration. Another typical feature of Coastal Ware; spatula or finger-tip impressions on the top of the rim of the jars; is totally absent here. Evidence from the nearby fortified settlement at Aardenburg suggests that these impressions became less and less fashionable and eventually disappeared during the 3rd century (W Dhaeze *in prep*). The sherd Fig 20, no 13 shows a burnished band and vertical lines. The body of a small jar is totally burnished (Fig 20, no 17). Soot on the exterior walls of many vessels indicates that this

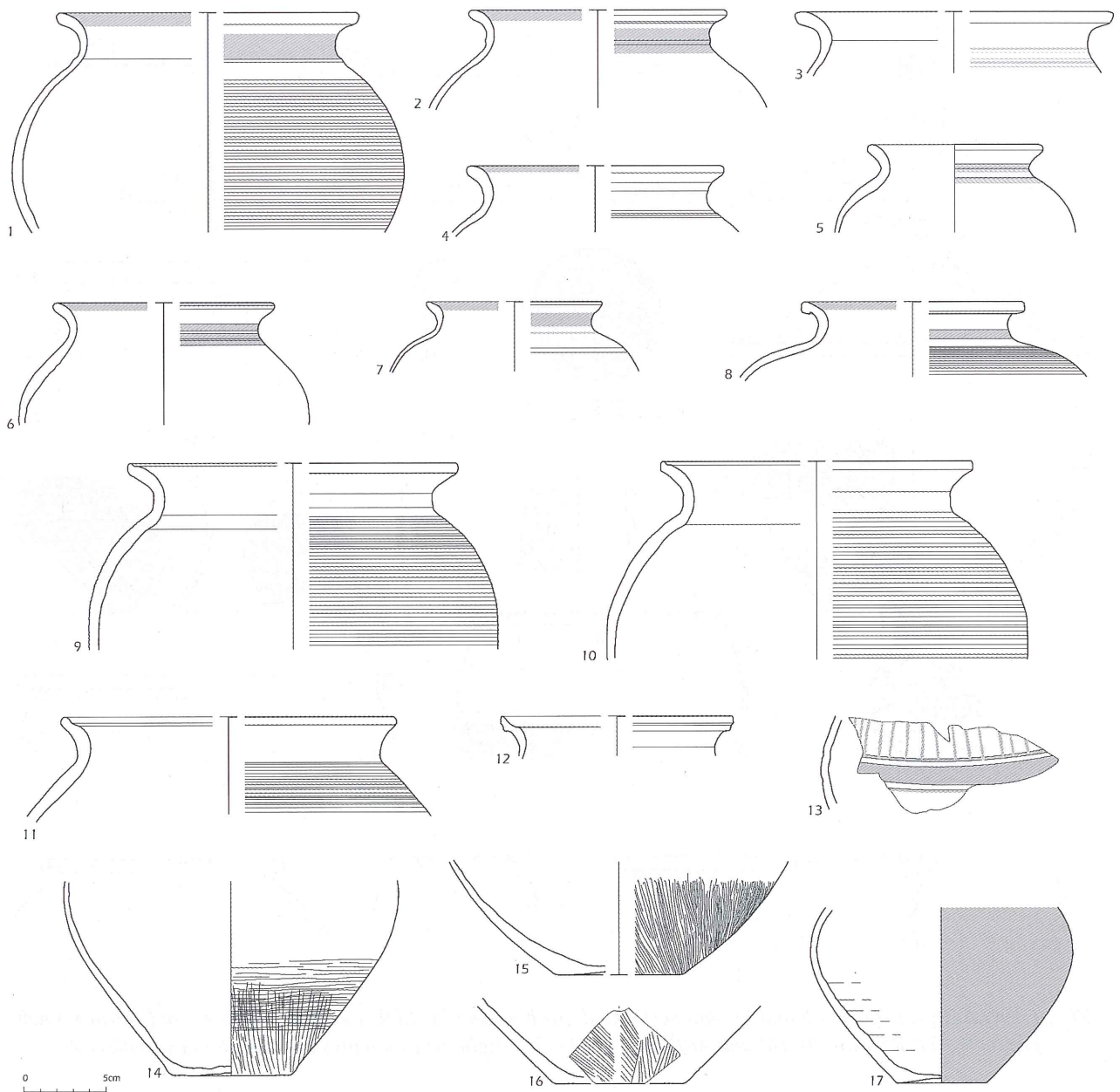

Fig 20: NOM RE jars, light grey indicates burnished areas, scale 1:4

type of jar was probably used for cooking.

Type 16: Globular jar with everted lid-seated rim (Fig 20, nos 11–12), 11 MNI, globular jars have a broad grooved rim, to provide the seating for a lid. While some of these vessels are similar to the previous type (Fig 20, no 11), others display a more hooked rim (Fig 20, no 12) which does not occur in the main typology of Coastal Ware (Thoen 1978), but is quite common at the end of the 2nd and the first half of the 3rd century, and has been found at the vicus of Aardenburg (N) (De Visser 2001, 151 and fig 9, no 68), at the vicus of Oudenburg (Gilté 1993, 117), at Dudzele (Hollevoet 1989, fig 7, no 14),

and at Brabers near Haamstede (N) (Trimpe Burger 1995, 44 and fig 38, no 6).

Lids: These form *c* 17% of the total MNI. Three types could be identified. Only the knobs of a few specimens survive, one of these is perforated. Of the 13 (MNI) vessels of which a substantial part of the vessel survived or of which the profile could be reconstructed, three are undecorated (Fig 21, nos 2 and 5 and not illustrated), nine are decorated with concentric burnished lines or bands (eg Fig 21, nos 1 and 4) and one has concentric burnished lines and vertical burnished lines in a radial pattern (Fig 21, no 3).

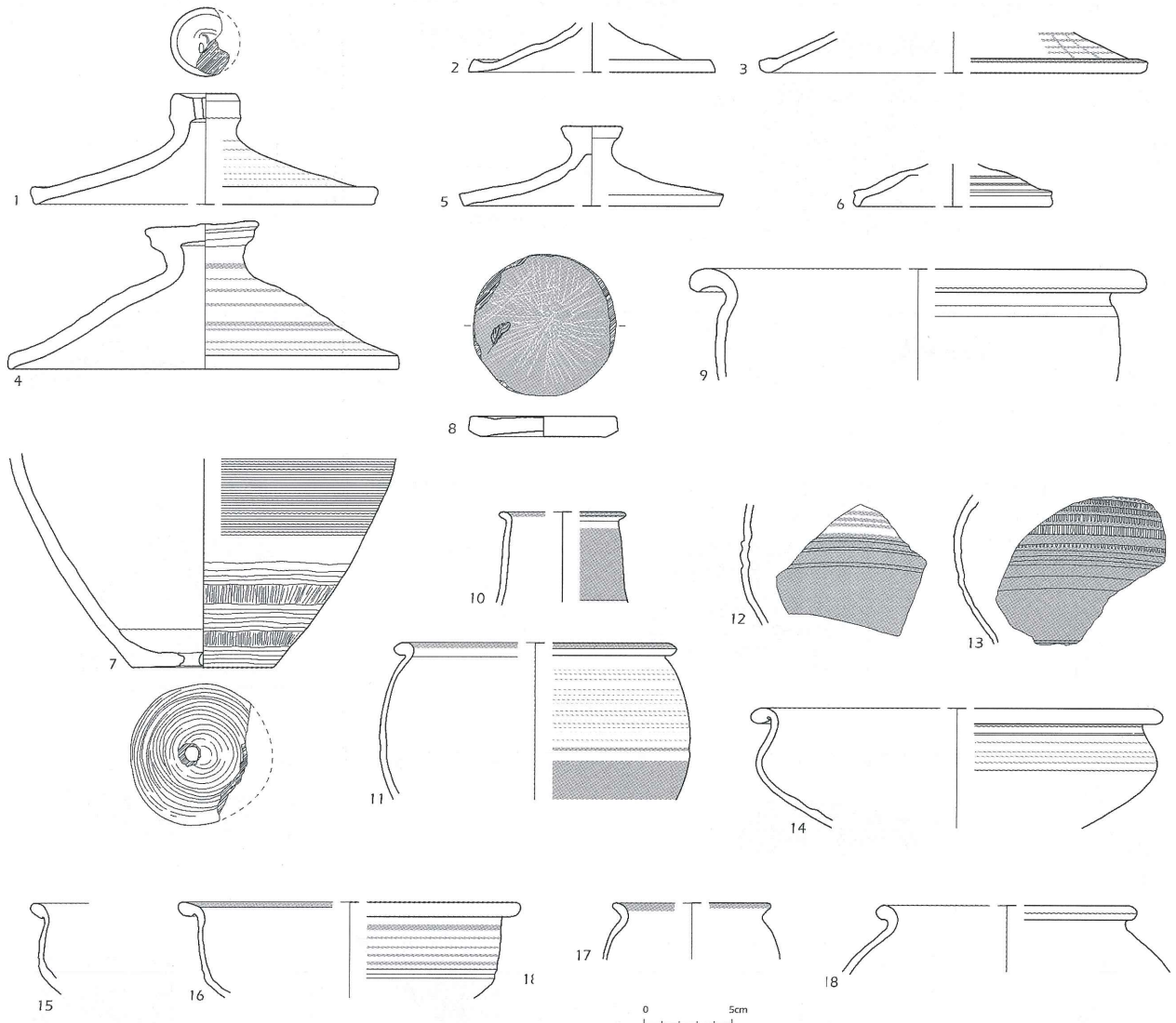

Fig 21: NOM RE lids (nos 1–5 and 8), and perforated jar base (no 7); LLW 1 container (no 9), and North French products ATR RE (nos 10–16) and ARD RE (nos 17–18), light grey indicates burnished areas, scale 1:4

Type 17: Lid with rounded rim (Fig 21, nos 1–3).

Type 18: Lid with cut-off rim (Fig 21, nos 4 and 5).

Type 19: Lid with profiled rim (Fig 21, no 6).

Also worth mentioning is the base of a bowl with interior burnishing (Fig 21, no 8), which seems to have been used as lid. The print of a leaf can be distinguished on it. Also a jar with perforated base and horizontal and vertical scored combed decoration (Fig 21, no 7), the function of which is unknown.

Low Lands Ware 1

LLW 1: 1 MNI. A (storage) jar or container rim fragment (Fig 21, no 9) of the Holwerda 142 type

(De Clercq and Degryse 2008; for fabric description see above). Rounded, downturned rims of this type are an important 3rd century chronological indicator. Low Lands reduced ware is found at Roman sites in the region to the east and north of the Scheldt, but is rare at those to the west of it. The Coastal Plain is situated outside the main distribution zone of this ware, but some vessels do find their way there.

Northern French imports

Fabrics with sources in Northern France together form only 2.6% of the total sherd count, 9.1% of the total MNI. Imports from northern France become more important in the levels of the phase following that to which OS 4980 belongs.

Atrebatian reduced ware

The Atrebatian reduced ware category includes various fabrics from the Artois region in northern France, broadly the *civitas* of the Atrebates with Arras (*Nemetacum*) as its capital. There are pottery production centres at Labuissière, Bruay-la-Buissière and Dainville (near Arras). Like other wares originating from northern France (CALO RE, ARD RE, CAM RE) this fabric, with 14 MNI, is rare in this pottery assemblage.

Fabric

ATR RE: Grey wares with a clean clay matrix, and often a laminated appearance containing common to abundant fine, sub-rounded, grey, semi-translucent quartz grains, as well as moderate quantities of black fine iron-rich particles (Col Pl 2, j).

Typology

Carinated bowls with a hooked rim ('bols carénés'): 5 MNI (Fig 21, nos 14–16) with either a sharp carination (Fig 21, no 16), or rounded (Fig 21, nos 14 and 15). The neck is always decorated with horizontal burnished lines or bands.

Collared bowl: 1 sherd.

Beakers with tall straight necks: ('vases tronconiques') (see Tuffreau-Libre 1980, 97 ff) with horizontal burnished lines externally (Fig 21, no 12), 3 MNI. The tall necks are typical of 3rd century beakers produced in northern Gaul. One beaker has a globular body decorated with a horizontal row of rouletting (Fig 21, no 13). A beaker with a straight neck, burnished with horizontal lines (Fig 21, no 10), has a fabric that was initially categorised as Atrebatian reduced ware, but it is more likely to come from elsewhere since this type of decoration is not common on Atrebatian products, but is very common on the Coastal Plain (Thoen 1978, LOK type 10).

Small jar: A globular jar with horizontal burnishing on the upper part of the body and a folded rim (Fig 21, no 11), and a small jar with short everted rim complete the range of forms.

La Calotterie reduced ware

Three sherds or 2 MNI probably came from the production centres of La Calotterie, near Etaples (c 15 km to the south of Boulogne, on the estuary of the Canche) (Ketels 2001). In later levels at the Oudenburg fort La Calotterie reduced ware is more abundant. The layer which seals the primary fillings, for example, contains a higher percentage of it. La Calotterie pottery was produced from the 1st to the 4th century AD (Ketels 2001).

Fabric

CALO RE: A red-brown or light-grey core, grey, brown-grey or dark-brown margins and temper of moderate to common sub-rounded, semi-translucent grey quartz grains and orange and brown iron-rich grains (Col Pl 2, k). The surfaces are rough to the touch.

Ardres reduced ware

Eleven sherds, 7 MNI are in a fabric which is very common in the southern part of the *civitas Menapiorum*. When first recognised at Ardres (Florent and Cabal 2004), it was provisionally labelled 'Ardres reduced ware'. It is possible, but not yet proved that this ware was manufactured at Ardres. Significant quantities of this fabric were found in Théroouanne, the capital of the *civitas Menapiorum*, and at Boulogne (Dhaeze and Seillier 2005, 631).

Fabric

ARD RE: Dark-grey fabric, sometimes with a light-brown or red-brown core, moderately tempered with fine, opaque grey, sub-angular quartz grains, white mica, sparse black iron-rich grains and calcite (Col Pl 2, l). The surfaces have a very rough feel.

Typology

Three vessels are examples of the type-fossil of this tradition: shoulderless globular jars with sharply carinated rims (Fig 22, no 1). Another vessel is a small jar with short everted rim (Fig 21, no 17), two more jars have a rounded rim (Fig 21, no 18), a type also known at the La Calotterie kilns. Two jar base-sherds also occur in this fabric (Fig 22, no 2).

Cambrai reduced ware

Three sherds, 1 MNI, probably originating from the Cambrai region (R Clotuche *pers comm*).

Fabric

CAM RE: Fine-textured light-grey fabric with white margins and pale-grey surfaces, abundantly tempered with very fine, sub-angular, colourless quartz grains, with some black and brown iron-oxides of various sizes, showing spots and strings.

Typology

The sherds are from a bowl with a thickened rounded rim (Fig 22, no 3), with upper part of the rim and the vessel interior burnished. Just beneath the rim is a perforation hole of 2.5mm.

Unprovenanced reduced ware: ?COL BB2

4 sherds, 3 MNI are in a fabric that is very similar to that of the Colchester BB2. However the types are not fully consistent with a Colchester origin (Dr M Lyne *pers comm*).

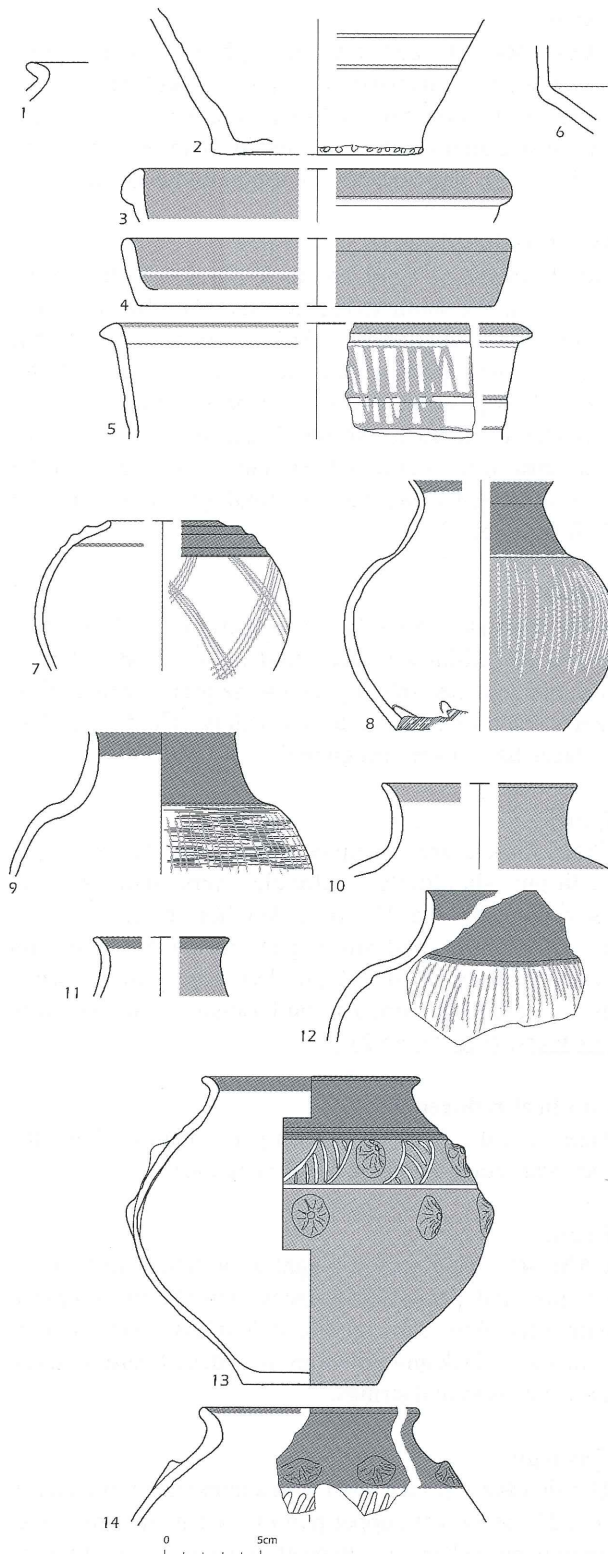

Fig 22: North French reduced ware ARD RE (nos 1–2), CAM RE (no 3), possible Colchester BB 2 products (4–6) and globular bowl, globular beaker and ‘stud-beaker’ in NOM HA fabric (nos 7–13), light grey indicates burnished areas, dark grey black coated areas, scale 1:4

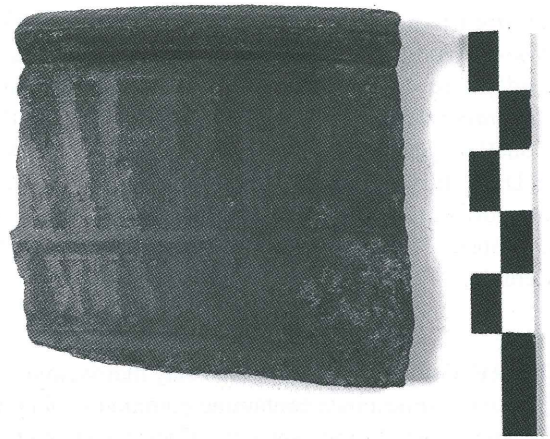

Fig 23: Possible Colchester BB2 rim sherd (Fig 23, no 5) (photo: copyright VIOE), scale marked in cm

Fabric

?COL BB2: A black, hard fired fabric with a moderate to abundant quantity of well sorted quartz (Col Pl 2, m).

Typology

One sherd is from an undecorated plain-rimmed dish (Fig 22, no 4), burnished on both sides. The second is a rim sherd of a bowl with triangular rim, and a cordon halfway down the exterior (Fig 22, no 5; Fig 23), burnished inside and outside and decorated externally with vertical burnished bands, finally there are two wall-sherds of a carinated bowl with horizontal burnishing on the interior and exterior (Fig 22, no 6). Plain-rimmed dishes like the first vessel were produced at Colchester (Symonds and Wade 1999) but carinated bowls were not, nor are the cordon and the vertical burnished bands of the second vessel present among Colchester products.

Discussion

Almost all the coarse reduced ware fabrics are of local or regional origin. North Menapian reduced wares (NOM RE) form a separate industry, which can be easily distinguished from the products of other regions. Although the fabric is very homogeneous, the variations in types seem to indicate that regional variations exist in the Coastal Plain and the border of Sandy Flanders. The range of forms found in North Menapian coarse reduced ware partly follows the native Gaulish tradition of globular cooking-pots and incurved-walled bowls, and partly copies Roman pottery, eg carinated bowls with horizontal rims (Fig 24). It is also important to note that the range of North Menapian reduced ware in OS 4980 does not differ from pottery assemblages from civilian contexts.

Other reduced wares, although they are present only in small quantities, came primarily from northern France. Since a substantial part of this material comes from coastal regions (La Calotterie, Ardres) it may be evidence of trade-contacts with this part of Gaul, which has always provided some ceramics for the North Menapian area.

Handmade pottery

Handmade pottery forms the largest group in the assemblage, 2374 (42.1%) of the total of 5640 by sherds count, 298 (40.32%) of the 739 MNI. All the handmade pottery was fired in a reduced atmosphere, producing black or dark-grey surface and core. Most of the vessels in this group were finished on a slow-wheel or turntable. Traces of turning are rare but obvious where they do occur, very irregular on the body but more regular on the rim. Most of the handmade pottery is considered to be of local or regional manufacture because of the distinctive association of forms, fabrics and decoration in the North Menapian coastal area, and has been called North Menapian handmade (NOM HA). This group together with its more fine-textured wheel-thrown equivalent (*above*), was formerly called ‘Coastal Ware’ (Thoen 1978), but new research shows that this is no longer appropriate. Rarer examples of handmade pottery are the

Romano-British imports in typical South-East Dorset BB1-fabric (DOR BB1) and others provenanced from the Yser estuarine regions.

North Menapian handmade

Most of the handmade sherds are made in NOM HA ware (2333: 98.3% of the group), representing 291 MNI (97.7% of the handmade total).

Fabrics

The fabrics were classified according to the characteristics and size of temper and clay matrix.

NOM HA 1: Fine textured fabric of abundant fine, well-sorted sub-rounded milky semi-translucent quartz grains with some ill-sorted grey-coloured clay-pellets (<1 mm) and some charred organic (plant) remains in low to moderate quantities (Col Pl 2, o).

NOM HA 2: Fairly coarse textured fabric with abundant fine and sparse ill-sorted sub-rounded or angular milky, semi-translucent quartz grains and ill-sorted grey-coloured clay-pellets (< 2.5 mm) with some charred organic (plant) remains in moderate quantities (Col Pl 2, p).

NOM HA 3: Coarse textured fabric of abundant fine and

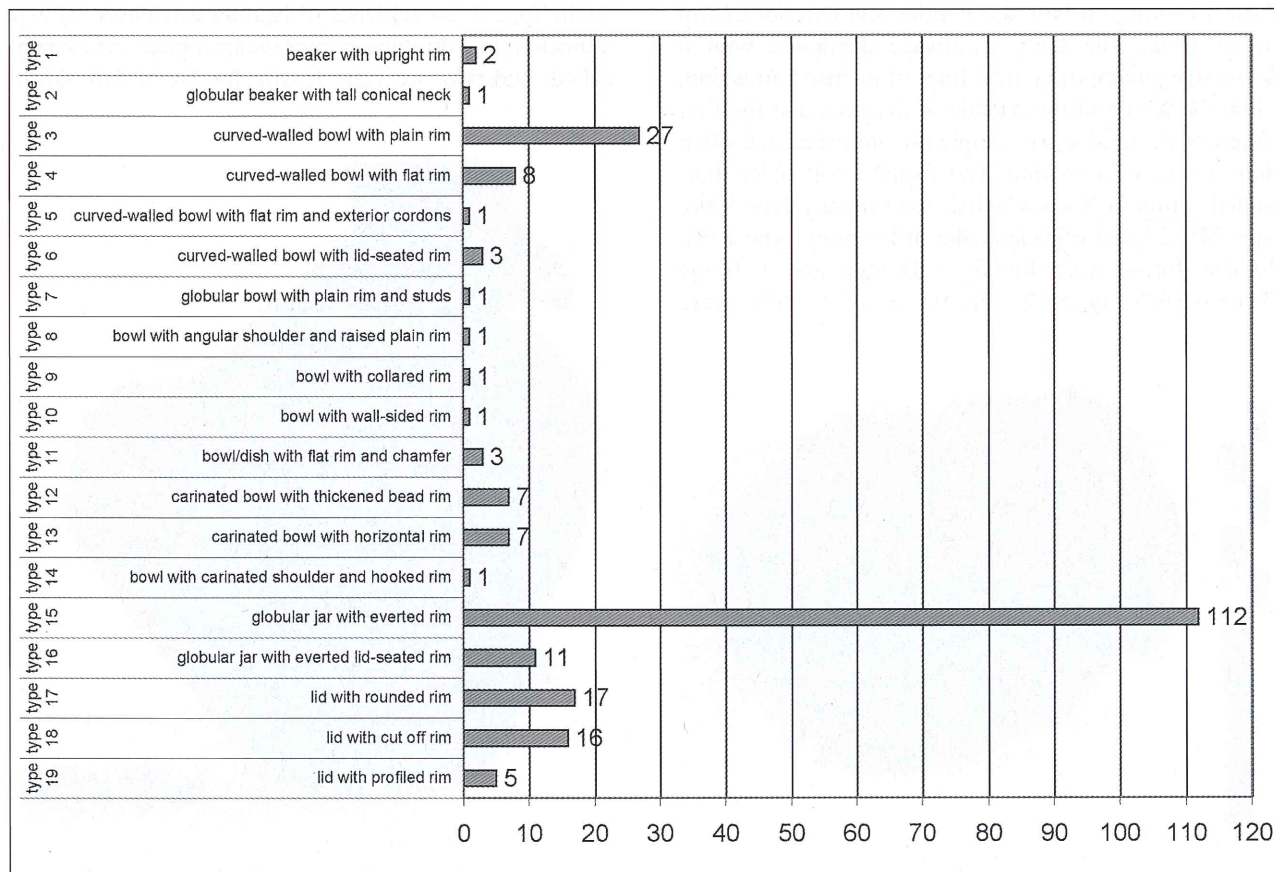

Fig 24: Vessel forms in NOM RE by MNI

very sparse ill-sorted sub-rounded or angular milky semi-translucent quartz grains, white rounded inclusions (<5mm), possibly chalk; ill-sorted grey-coloured angular or laminar clay-pellets (<5 mm) and charred organic (plant) remains in moderate quantities (Col Pl 2, q).

Typology and decoration

Of 298 MNI in handmade wares, 13 different vessel forms were distinguished including cooking pots, storage jars, beakers, bowls, dishes, cups and lids, divided into sub-types according to details of rim and profile.

Type 1: Small globular bowl with profiled rim and burnished lattice decoration on the wall. Represented by 1 MNI, with the remains of a black coating on the outside of the rim (Fig 22, no 7; Fig 25). The type could have been influenced by the Cam 328 form (Hull 1963) globular bead-rim jars occurring in the BB2 tradition. It has the type's general form and decoration.

Type 2: Globular beaker with pronounced shoulder, tall upright neck, weakly everted rim and globular body. Represented by 9 MNI, mostly in fabric 2 (7 MNI) (Fig 22, nos 8–12). All the sherds bear a black, often shiny coating on the neck and in some cases on the interior of the rim. Two examples (Fig 22, nos 9 and 11) show a coating on both the interior and exterior of rim and/or neck. The body is always decorated with a distinctive pattern of vertical lines of intense burnishing, while the whole of the outside of the neck and the first 10mm of its interior are completely burnished and often show traces of a coating. The forms recall older thin-walled forms in North-Gaulish terra nigra (Deru 1996, type P46–53 and especially the 3rd century type P53). Related forms were found in Brugge and Leffinge (Thoen 1978, type 8). No traces of heating were

observed and the delicate finishing of most vessels in this type suggests this form was not used for cooking. A function as tableware, possibly a beaker for drinking, seems more plausible. Similar forms were made in the wheel-thrown fabric NOM FR. A rare inland find of a beaker of this type was found in a 3rd century context at Velzeke (van Heesch and Deschieter 2000, fig 11, no 9).

Type 3: Globular, almost shoulderless pot with everted rim, decorated with studs (so-called 'stud-beaker' or 'knobbelpot' in Dutch): represented by 10 MNI, seven in the fine NOM FR (see Fig 13, no 6 and Fig 15), and three in the coarser NOM HA 2 version (Fig 22, nos 13 and 14; Fig 26). The high quality of these vessels is shown by the intense burnishing on the body of the vessel. As in the Type 2 forms, the whole outside of the neck and the first 10mm of the interior are completely burnished and often show traces of coating. These pots have a series of applied, stud-like elements on the girth and on the shoulder (two rows). In some examples this area is also decorated with geometric patterns of burnished lines. The use on handmade vessels of applied elements to enhance the grip is not completely unparalleled in Northern Gaul (Herbin 2002). However, the high density of stud-like elements in combination with the globular form, a fine-textured fabric, delicate burnishing and coating defines this as a distinctive form. As in Type 2, no evidence of heating was observed and a function as a drinking beaker seems logical. As already stated stud-pots are type fossils for NOM HA fabric



Fig 25: NOM HA 1 globular bowl (Fig 23, no 7) (photo: copyright VIOE), scale marked in cm



Fig 26: NOM HA 3 'stud-beaker' (Fig 23, no 13) (photo: copyright VIOE), scale marked in cm

pottery production, occurring from the late 2nd century onwards but predominantly of 3rd-century date. Examples are known along the North Menapian coast at Brugge (Thoen 1978, 186, LOK 9), Wenduine (*ibid*, 141), Zeebrugge (*ibid*, LOK 9), Dudzele (Hollevoet 1989, fig 8, nos 14 and 15; In't Ven and Hollevoet 2005, fig DW4-1, 16), Plassendale (Vanhoutte and De Clercq 2007), the civil settlement of Oudenburg (Creus 1975, 13), Aardenburg and Maldegem (Dhaeze *in prep*). Wheel-thrown equivalents, often decorated with rouletted patterns were produced in NOM FR fabric (Fig 13, no 6).

Type 4-5: Dish with oblique wall and in-curved rim (Type 4) (Fig 27, nos 1-6 and 8) and in some cases the wall of the pot has been pushed-out to produce a pouring lip (Type 5) (*cf* Fig 27, nos 7 and 9). Type 4 dishes are represented by 19 MNI, almost equally divided between NOM HA 1 and 2 (8 and 11 MNI respectively). The form was already present in the early 1st century AD and is closely related to the bowl Type 6 below. With the handmade pottery revival during the 3rd century (De

Clercq 2005), this often entirely burnished dish is abundant throughout North-western Gaul, also occurring in more distant inland territories such as Velzeke (De Mulder and Deschietter 2003, 281). Most dishes from the Oudenburg assemblage were entirely burnished both inside and out. Coating on the outside of the rim, and burnished vertical lines on the outside wall are distinctive elements for the late 2nd and 3rd century production. Dishes completely burnished on the interior could have been used as a cooking or frying plate. The burnished surfaces would improve the heating efficiency and the burnished interior would prevent cooked substances adhering (Ikäheimo 2003, 96).

Type 6: Bowl with oblique wall and incurved rim: 67 MNI (9 in NOM HA 1, and 37 in NOM HA 2) (Fig 27, nos 10-15). This simple handmade bowl type is found in most of the pottery assemblages of the first half of the 3rd century AD in the *civitas Menapiorum* (Vermeulen 1992, 105-6: bowl Type 7) and is similar to the Type 4 dish. The abundant use of burnishing on the inside and outside is typical of 3rd century contexts in the northern

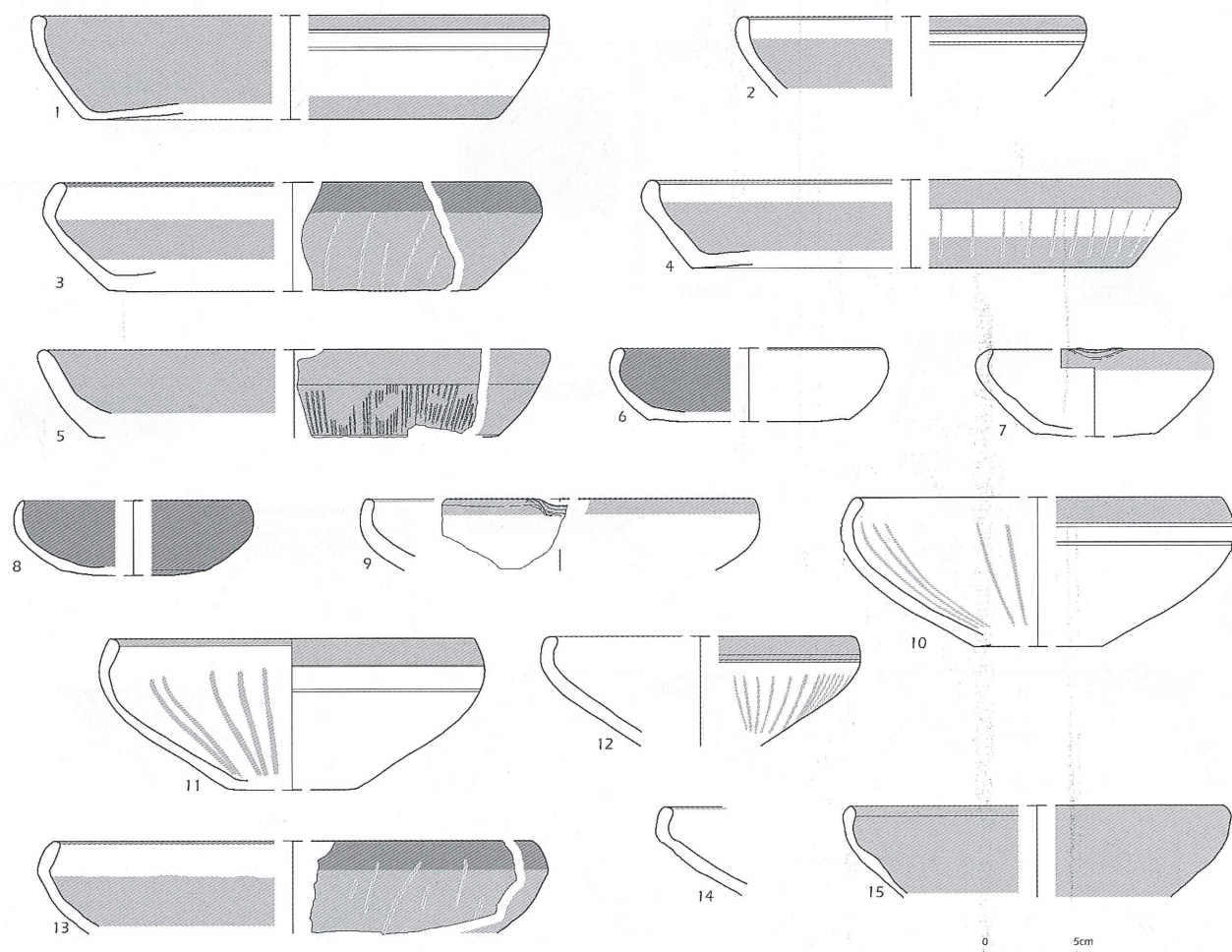

Fig 27: NOM HA dishes and bowls, light grey indicates burnished areas, dark grey black coated areas, scale 1:4

(coastal) area. As in the Type 4 dishes, the outside of the rim often has a black coating or burnishing, or vertical burnished lines on the inside and outside surfaces. The interior surface is completely burnished.

Type 7: Bowl with oblique wall and rim sharply carinated to the inside. Only 1 MNI (NOM HA 2) was present (Fig 28, no 1). The type is rare in handmade ware but occurs from the 2nd century onwards in the wheel-thrown fabric LLW 1. Similar forms occur in NOM RE fabric (*see above*).

Type 8: Bowl with oblique wall and inturned rim. Five MNI (all NOM HA 2) were found (Fig 28, no 2). Similar decorative patterns to those of Types 4 and 6

were observed. The form is more frequently found in northern inland territories (between Ghent and Bruges) (Vermeulen 1992, 105: type 5) in contexts which can be dated from the Flavian period until the 3rd century AD. Finds from Merendree, Knesselare, Zomergem and Aalter indicate that this form is most abundant in the 3rd century AD (De Clercq *in prep*). Some pieces show a black coating on the exterior and interior of the rim.

Type 9: Bowl with S-shaped profile (rim everted to the outside). Three MNI (all NOM HA 1) occur (Fig 28, nos 3–5; Figs 29 and 30). Two sherds show a coating on the inside of the rim. The shoulder was polished in all cases, and the outside decorated by vertical-line burnishing. The MNI may be underestimated since shoulder or rim sherds

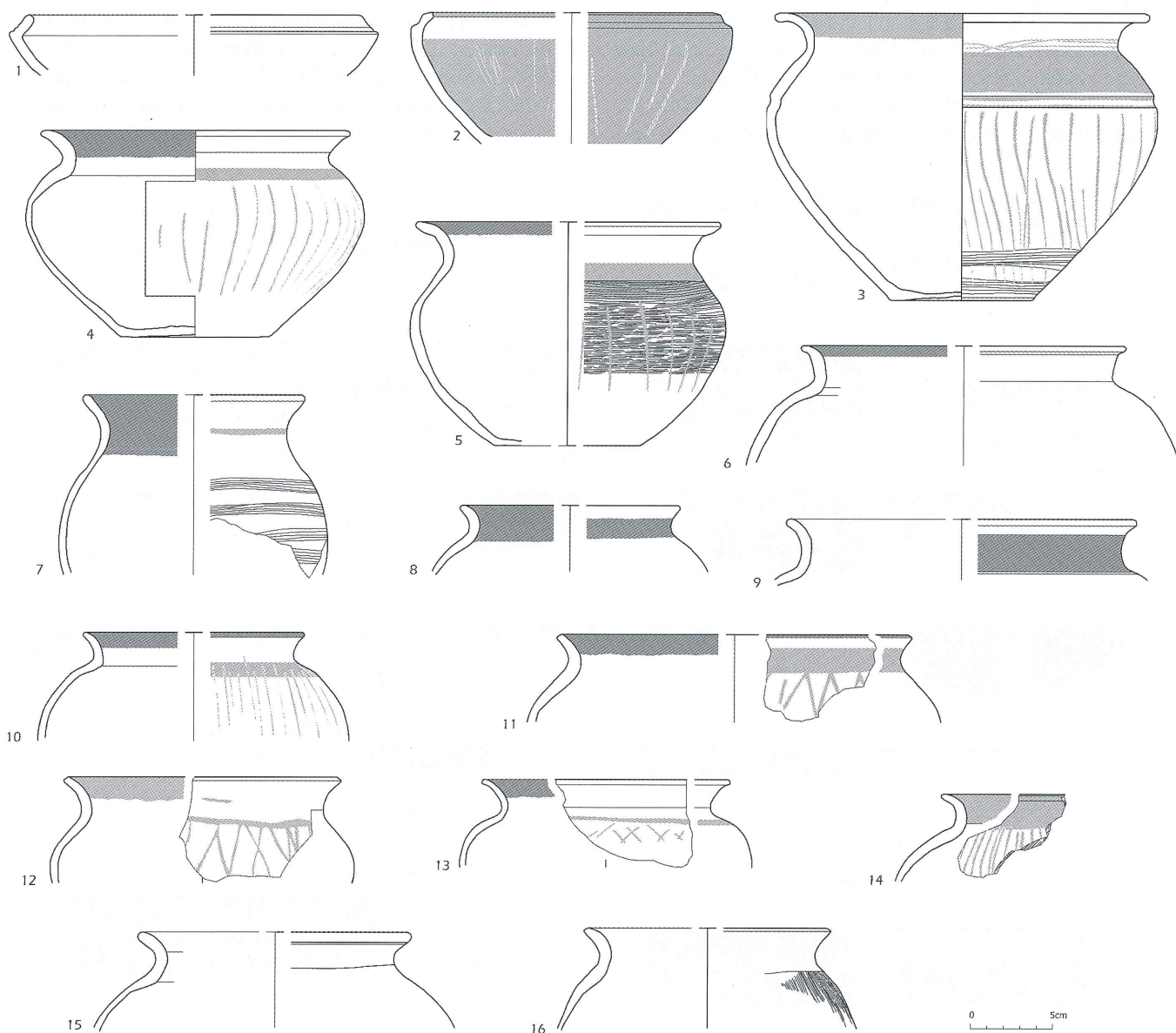

Fig 28: NOM HA bowls and jars, light grey indicates burnished areas, dark grey black coated areas, scale 1:4



Fig 29: NOM HA 9 bowl (Fig 28, no 3)
(photo: copyright VIOE), scale marked in cm



Fig 30: NOM HA 9 bowl (Fig 28, no 4)
(photo: copyright VIOE), scale marked in cm

could also belong to Type 10 cooking pots (*below*) and these sherds were included in the Type 10 totals. Handmade S-shaped profile bowls are found in large areas of Northern Gaul (eg Vermeulen 1992, 105: bowls Type 1). The form dates back to the late Iron Age and continued well into the Roman period. The specific decoration on the Oudenburg pieces relates them to other forms in the NOM HA fabric such as Types 4 to 9.

Type 10: Jar with globular body and everted rim, often described as a cooking-pot. A total of 134 MNI (44 in NOM HA 1; 86 in NOM HA 2; 3 in NOM HA 3) makes this form the dominant type in the NOM HA fabric as well as in the total assemblage (Fig 28, nos 6–16; Fig 31, nos 1 and 2). Some sherds show intense traces of soot on the lower parts of the body. The abundant use of burnishing and coating is typical of the 3rd century AD NOM HA fabric tradition. Many sherds show coating on the inside of the rim, while the outside of the rim is totally burnished. The wall may be totally burnished or with burnished vertical lines or lattice pattern. Combinations of different patterns occur. Comb-scored patterns are rarer on the wall but more frequent on the lower body of vessels. The shoulder can be curved or more angular. As Type 9, the form dates back to the Iron Age and is found on many Roman sites (1st–4th century AD) in Northern Gaul (eg Thoen 1978; Vermeulen 1992, 108, type 1; De Clercq *et al* 2005). While the basic form remains unchanged through time and landscapes, the decoration often shows significant regional variations, possibly indicating distinctive regional and chronological traditions of pottery manufacture. The lattice-decoration also occurs on material from inland sites west of the river Scheldt, but from the mid 3rd century onwards the use of a coating and the absence of

the fingertip impressions on the rim, which are a distinctive feature of the handmade pottery from the area between Ghent and Bruges, clearly distinguishes the Oudenburg group from inland products.

Type 11: Shoulderless jar (cooking-pot) with globular body and rim sharply carinated to the exterior. 17 MNI (six in NOM HA 1; nine in NOM HA 2 and two in NOM HA 3) were found (Fig 31, nos 3–7). The form is typical of the coastal area and does not occur in inland handmade fabrics. The absence of a shoulder relates this form to BB1 and BB2 cooking-pots or similar forms from other continental coastal areas, such as a distinctive group decorated in comb-scored patterns and with a burnished rim in the Yser–Aa estuarine zone on both sides of the modern French–Belgian border (eg Roumegoux and Termote 1993, fig 51; Hanois 1996, fig 2; Bouche and Michel 2004) and a similar group decorated with rouletting in the northern part of the *civitas Menapiorum* (Florent and Cabal 2004; Dhaeze and Seillier 2005, 631, fig 32). One piece (Fig 31, no 4) in the more coarse NOM HA 3 fabric has a distinctive surface decoration of arcaded comb-score patterns and the rim is decorated with a double row of finger-tip impressions. Such comb-scored patterns on these forms are known in the Yser–Aa group. A collection of old finds, made during peat-extraction at Wulpen near Veurne close to the Yser (De Wilde and Verhaeghe, *unpub*) contained many very similar forms, and an origin in this region is probable. A parallel for this piece comes from the 3rd century New Fresh Warf pottery group in London (Richardson 1986, 126, fig 1 no 185). Comparison of hand specimens revealed a close resemblance between the London and Oudenburg pieces (Col Pl 2, r).

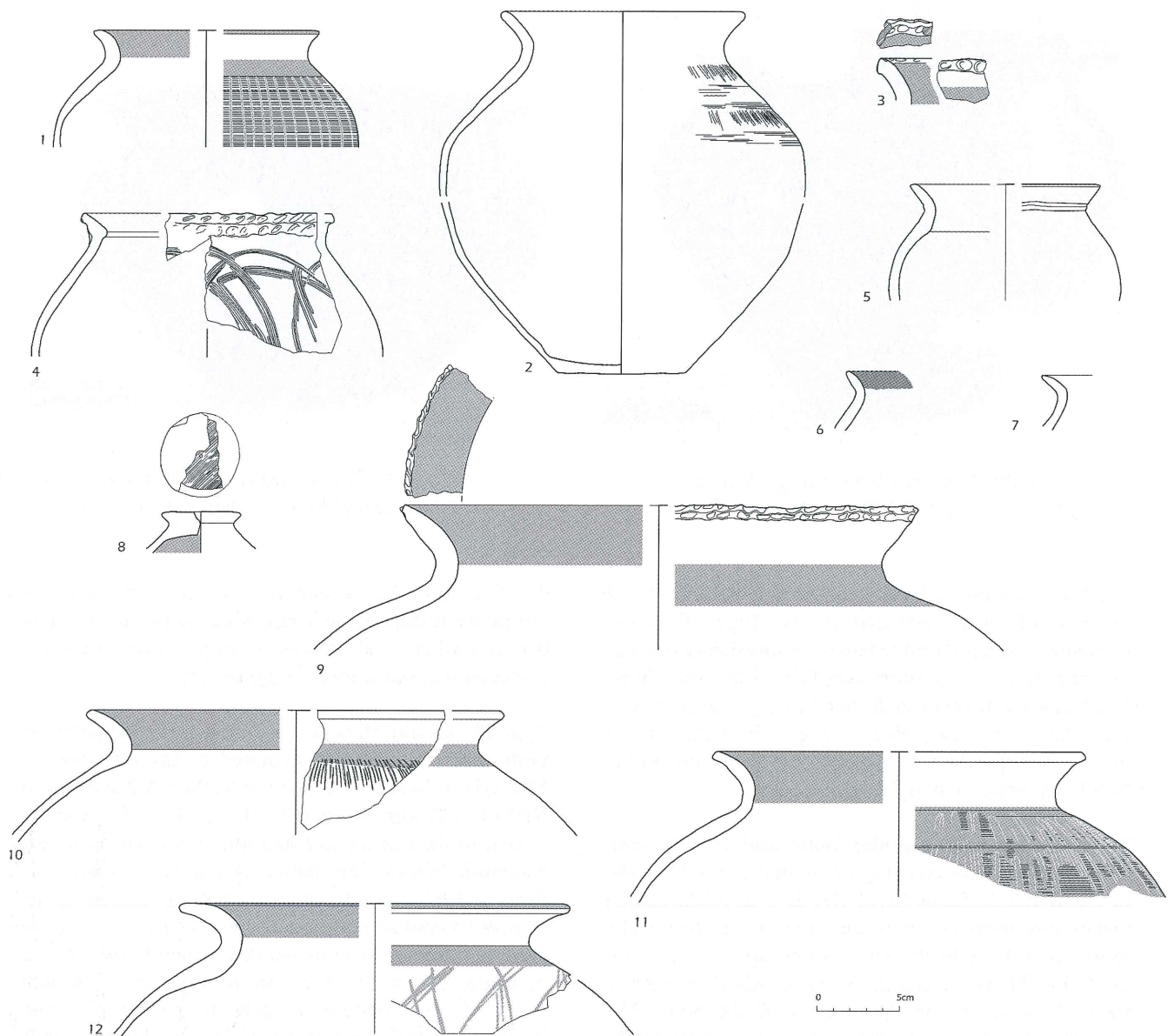

Fig 31: NOM HA jar types and lid knob (no 8), light grey indicates burnished areas, scale 1:4

Type 12: Lid with plain rim. Only 2 MNI were present (Fig 31, no 8). This absence of lids in the NOM HA pottery group seems to be a distinctive characteristic since lids are abundant in the handmade group from the adjacent inland area between Ghent and Bruges.

Type 13: Large storage jar with globular body and everted rim. Represented by 11 MNI (one in NOM HA 1, five in NOM HA 2, and five in NOM HA 3) (Fig 31, nos 9–12; Fig 32, nos 1–9). Its large dimensions and the absence of soot on the surface, mean that this large variant of the Type 10 cooking-pot is commonly interpreted as a storage-vessel. Again, (irregular) lattice

decoration on the body of the pot is frequently observed while the shoulder is decorated with closely arranged vertical lines of burnishing. The rims are completely burnished both inside and outside. The inside surface often shows fingerprints or irregular marks of the manufacturing process. One piece was decorated with a black coating and with fingertip impressions on the outside of the rim (Fig 31, no 9). These forms and the associated decoration are known from several 3rd century AD sites in the North Menapian area such as Aardenburg, Maldegem, Middelburg, Plassendale (Vanhoutte and De Clercq 2007) and Haamstede (Trimpe-Burger 1995, fig 56, nos 3 and 4).

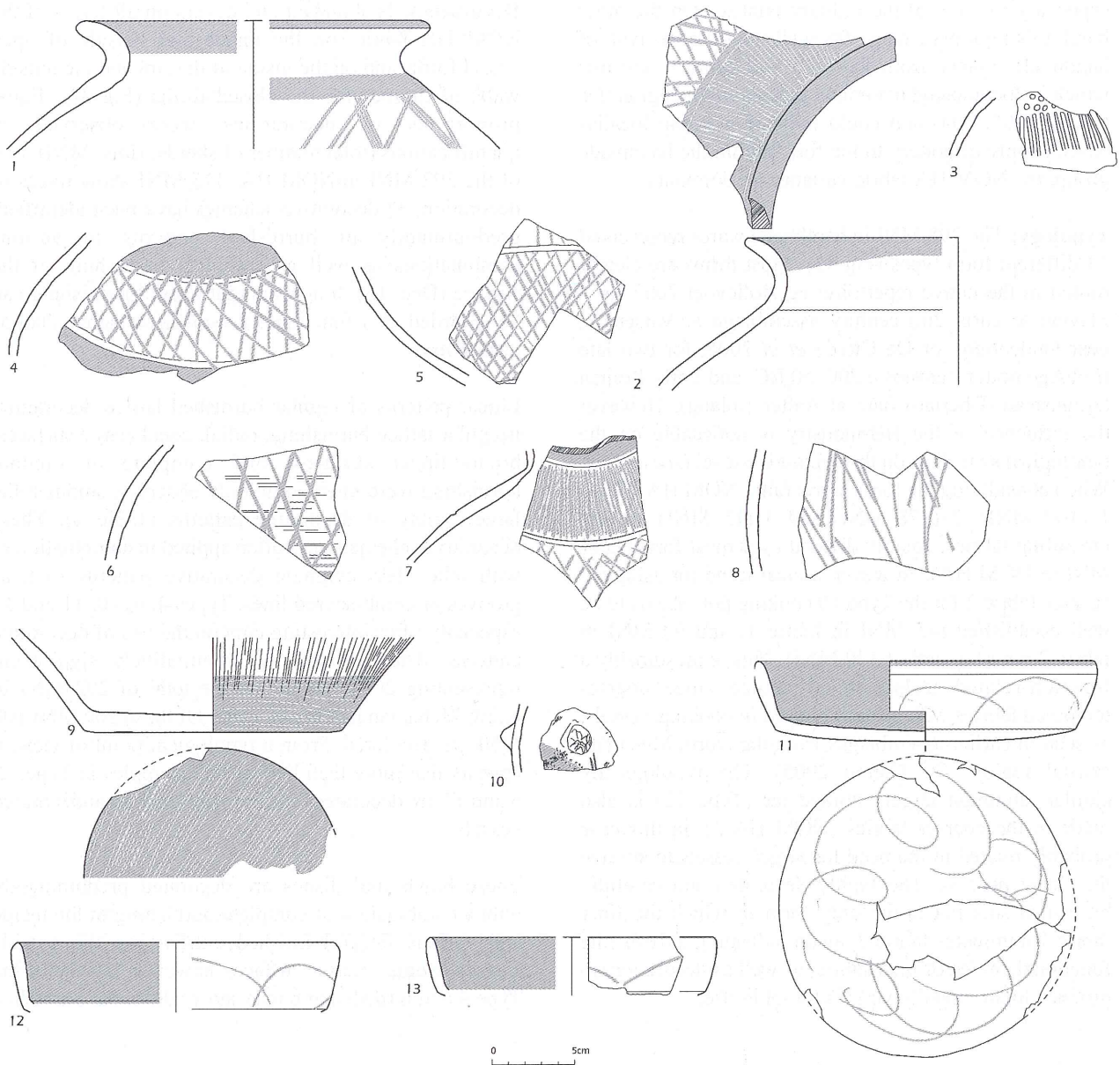

Fig 32: NOM HA storage jar fragments (nos 1–9) and the DOR BB 1 (nos 7–12), light grey indicates burnished areas, scale 1:4

South-East Dorset black-burnished ware 1

A small quantity of 23 sherds or approximately 1%, 6 MNI or 1.35% of the handmade fabrics, is Romano-British in origin.

Fabric

DOR BB1: Five of the six vessels fall into the ‘classic’ DOR BB1 fabric (Col Pl 2, n); one fragment has a much finer fabric.

Typology

All the vessels are plain-rimmed dishes, of Holbrook and Bidwell (1991) type 59.3. All except one (Fig 32, no 13)

are decorated with an external burnished arcaded and intersecting arc decoration (Fig 32, nos 11 and 12). The exterior of the base is decorated with curving burnished lines. Only the interior wall is completely burnished. Four dishes can be more precisely identified: three sherds as Bestwall dish form 8/5 (Fig 32, nos 11 and 13), dated AD 220–300, one as a Bestwall dish form 8/3, dated AD 220–70 (Fig 32, no 12) (Dr M Lyne *pers comm*).

Discussion

Handmade pottery is the largest group in the assemblage. More than 40% of the vessels in pit OS 4890 were in this category. This large proportion seems surprising at first,

especially in view of the military context. On the other hand, this high percentage fits well with the 'revival' of handmade pottery from the early 3rd century onwards which is documented in civilian context in the region (De Clercq 2005, 204) and could indicate a strong locally-based supply of pottery to the fort. Within the handmade group, the NOM HA fabric variants are dominant.

Typology: The 298 MNI in handmade wares represented 13 different form types (Fig 33). Most forms are clearly rooted in the native repertoire: eg Hollevoet 2002 for a Flavian to early 2nd century assemblage at Varsenare, near Oudenburg, or De Clercq *et al* 2005, for two late Iron Age pottery-groups *c* 200–50 BC, and Early Roman (Augustean–Tiberian) date at Aalter (inland). However the influence of the BB-industry is noticeable on the typological as well as on the decorative level (*see above*). When considering the form/fabric ratio, NOM HA fabrics 1 (100 MNI), 2 (178 MNI) and 3 (13 MNI) are the prevailing fabrics, equally divided over most forms (291 MNI in NOM HA). However, a clear trend for using the coarser fabric 2 for the Type 10 cooking pots seems to be well established (45 MNI in fabric 1, and 90 MNI in fabric 2 out of a total of 140 MNI). This is presumably a function-related technological choice since coarse-tempered fabrics were generally used in cooking-vessels, as seen in earlier assemblages from the North Menapian coastal region (De Clercq 2005). The typologically similar, although larger, storage jar (Type 12) is also made in the coarser fabrics (NOM HA 3), in this case probably related to the need for larger vessels to survive the firing process. The highly decorated and carefully burnished stud-pot is the only form in which the finer fabric 1 dominates fabric 2, again indicating a deliberate functional choice of finer fabric, as well as decoration, to produce higher quality vessels for table-use.

Decoration: Is abundant and occurs on all forms of the NOM HA fabric: on the inside and outside of open vessel forms and on the inside of the rim and the outside walls of the pot for the closed forms (Fig 34). Equal proportions of decorations were observed in quantifications (total number of sherds; rims; MNI). Out of the 292 MNI in NOM HA, 115 MNI show traces of decoration, 33 decorative schemes have been identified, predominantly of burnished patterns in various combinations as well as complete burnishing of the surface (Dec. 15). It appears that overall burnishing can be regarded as a functional vessel-finish rather than as decoration.

Linear patterns of regular burnished lattice decoration, irregular lattice burnishing, radial, zonal (large surfaces, broad linear surfaces) and complete or random burnishing were most commonly observed amongst the large variety of decorative patterns (Table 4). These decorative schemes were often applied in combination or with other, less common decorative patterns such as grooves or comb-scored lines. Types 4, 6, 10, 11 and 13 especially offer interesting data on the use of decorative patterns. These forms are quantitatively significant, representing 209 MNI out of the total of 292 MNI in North Menapian handmade ware. Of these 209 MNI 100 MNI are decorated. From a typological point of view, it appears that more than half of the examples in Types 2, 6 and 13 are decorated, while Type 4 had no undecorated vessels.

These bowls and dishes are decorated predominantly with a combination of complete burnishing in the inside and various linear burnished patterns on the outside surface. Some interior surfaces however, mostly in the Type 4 and 6 (dish and bowl) show additional burnished

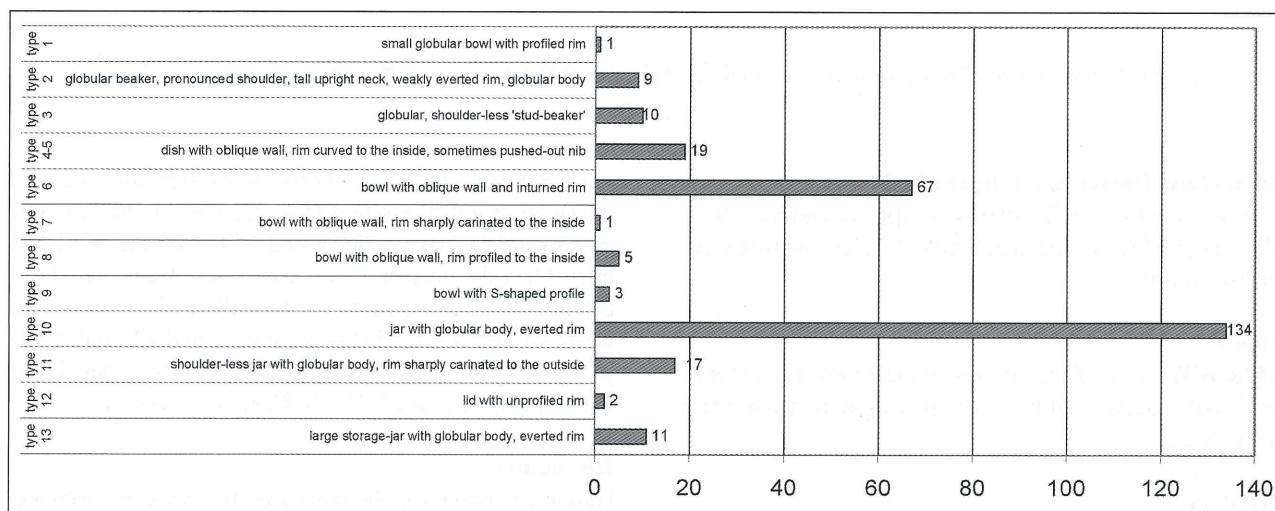

Fig 33: NOM HA types represented in MNI

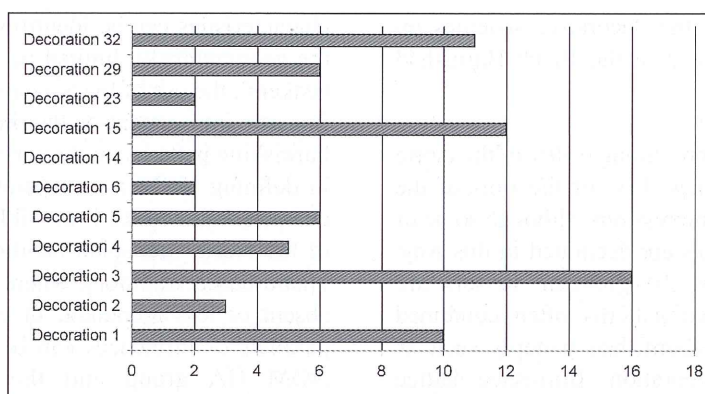

Fig 34: Decorative patterns on the handmade pottery by MNI (Patterns only occurring once are not included)

Table 4: Decorative schemes on NOM pottery vessels

Decoration/Form	Type 2	Type 4	Type 6	Type 10	Type 11	Type 13	Total
Undecorated	5	-	26	63	13	2	109
Decoration 1	-	-	-	7	2	1	10
Decoration 2	1	-	2	1	-	-	4
Decoration 3	5	-	-	8	1	-	14
Decoration 4	-	-	-	3	-	2	5
Decoration 5	-	-	1	2	-	2	5
Decoration 7	-	-	-	-	-	1	1
Decoration 9	-	-	2	-	-	-	2
Decoration 10	-	-	-	-	-	1	1
Decoration 12	-	-	7	-	-	-	7
Decoration 14	-	-	-	2	-	-	2
Decoration 15	-	5	-	-	-	-	5
Decoration 21	-	1	-	-	-	-	1
Decoration 24	-	-	-	-	-	1	1
Decoration 25	-	-	1	-	-	-	1
Decoration 26	-	-	2	-	-	-	2
Decoration 28	-	-	9	-	1	-	10
Decoration 29	-	-	1	-	-	-	1
Decoration 30	-	6	3	-	-	-	9
Decoration 31	-	-	12	-	-	-	12
Decoration 32	-	7	-	-	-	-	7
Totals	11	19	66	86	17	10	209

Key to decorative scheme codes (cf Table 4 and Fig 34)

On exterior only

- 1 Horizontal and/or vertical scored combing
- 2 Combined vertical parallel burnished lines on scored combing
- 3 Vertical parallel burnished lines
- 4 Grouped (intersecting or vertical) burnished lines
- 5 Zonal burnishing (strips or surfaces)
- 6 Burnished lattice decoration
- 7 Lattice combined with zones of burnishing
- 8 Radial burnishing in strips (multiple lines)
- 9 Radial burnishing in lines (single lines)
- 10 Zones of burnishing with intersecting burnished lines
- 11 Zonal burnishing with scored combing
- 12 Groups of burnished lines with scored combing
- 13 Comb scored arcaded patterns
- 14 Finger tip or nail impressions on the rim
- 15 Complete burnishing
- 16 Irregularly intersecting burnished lines
- 17 Irregularly intersecting burnished lines with scored combing
- 18 Dot impressions
- 19 Burnished lattice decoration with scored combing
- 20 Vertical grooves

On exterior and

- 21 Vertical parallel burnished lines
- 22 none
- 23 Zones of burnishing (strips or surfaces)
- 24 Finger tip or nail impressions on the rim
- 25 Vertical parallel burnished lines
- 26 Radial burnishing in lines (single lines)
- 27 Complete burnishing
- 28 Combined finger tip or nail impressions on the rim and comb scored arcaded patterns
- 29 Vertical parallel burnished lines
- 30 Zones of burnishing (strips or surfaces)
- 31 Radial burnishing in lines (isolated lines)
- 32 Complete burnishing
- 33 Radial burnishing in strips (grouped lines)

interior surface

- Vertical parallel burnished lines
- Zones of burnishing (strips or surfaces), horizontal and/or vertical scored combing, and vertical parallel burnished lines
- Zones of burnishing (strips or surfaces)
- Zones of burnishing (strips or surfaces)
- Radial burnishing in lines (single lines)
- Radial burnishing in lines (single lines)
- Radial burnishing in lines (single lines)
- none
- Complete burnishing
- Complete burnishing
- Complete burnishing
- Complete burnishing
- Zonal burnishing (strips or surfaces)

patterns, strongly recalling the decorative schemes on similar vessel-forms produced in the Black Burnished Ware industry.

The globular jar Type 10, representing *c* 30% of the fabric group has decorative schemes. Few of the rims of the Type 10 pot have fingertip impressions, although some of the Type 11 globular jar rims are decorated in this way. The surfaces of the Type 10 globular vessels are decorated with comb-scored patterns often combined with various kinds of line-burnished patterns such as vertical lines or lattice-decoration. Burnished lattice decoration is known in Northern Flanders from the first two centuries BC on Type 10 cooking pots (De Clercq *et al* 2005) and continues to be applied to this form throughout the Roman period. However, the diversity and intensity of burnished patterns seems characteristic of the late 2nd and the 3rd centuries AD in the northern part of Flanders and the coastal region in particular (eg Plassendale III; Vanhoutte and De Clercq 2007). Most of the forms in NOM HA, especially Types 10, 11, 13, show remnants of a black coating (possibly birch-tar?), mainly on the rim and shoulder, and often also on the interior of the rim. This finish is most apparent on those parts of the vessels that make contact during stirring, pouring and drinking. The use of a black coating on the rim is also found on certain South-Western Black Burnished Ware 1 forms (Holbrook and Bidwell 1991, 114 and figs 34 and 35, form 32.1).

Function: The Type 10 globular jar with everted rim dominates the handmade assemblage (53%), while bowls (28%) are also well represented. Large beakers (7%), dishes (7%), storage-jars (4%) and lids (1%) occur less frequently. The coating on the rims of cooking-pots, bowls and beakers could be related to hygiene or to facilitate drinking, stirring or pouring. The use of fine-textured fabrics and the fine finish and decoration of the Types 2 and 3 indicate that these forms were used as tableware, presumably as drinking beakers. The range of forms present within the handmade pottery group can be related to the whole process of food processing: storage, cooking and consumption. The potters producing these forms favoured the more coarse fabrics for cooking-pots.

The handmade pottery shows that on both typological and decorative levels there is a strong persistence of native pottery traditions in Northern Gaul and in the *civitas Menapiorum* in particular (Vermeulen 1992; De Clercq 2005). Pottery production was not however a centralised activity since differences in style, decoration and fabrics indicate significant geographical and chronological variations, which point to the existence of regionally-based production centres (De Clercq *in prep*). In the dominant NOM HA group, some specific technological, typological as well as stylistic

characteristics can be identified. The quartz rich fabric, the geographically limited occurrence of Type 3 'stud-beakers', the use of black-coating on the rim, the lack of fingertip impressions on the rim, and the abundant use of burnishing patterns on the surfaces are important criteria in defining NOM as a separate group (Fig 35). These characteristics make it possible to distinguish products of the North Menapian handmade tradition from other inland-based traditions where these characteristics are absent or less dominant. In contrast some remarkable parallels or influences can be established between the NOM HA group and the Romano-British Black Burnished Ware industry. The imitation of certain forms (Type 1), dishes imitating Holbrook and Bidwell (1991) type 59.3, the appearance of jars with wide, everted rims and sharply carinated bodies (Type 11), the use of the black coating and the application of burnished patterns, especially on dishes and bowls, clearly relates the NOM HA group to the Black Burnished ware group and to the other continental Black Burnished ware imitations (Tuffreau-Libre *et al* 1995) produced along the Channel coast further south. The Type 3 beaker also lacks obvious parallels in the native and earlier Roman handmade pottery repertoire but resembles a Black Burnished ware form. The presence of Black Burnished ware in the Oudenburg context, and also on other sites in the NOM region (see Aardenburg: De Visser 2001, 155 and fig 9, nos 87 and 88; Dhaeze *in prep*) may suggest that Black Burnished ware had a direct influence on the North Menapian handmade production. In addition these NOM HA characteristics seem to be limited to late 2nd and 3rd century contexts, the earlier products in this coastal area show more parallels and greater homogeneity with inland traditions (Assemblages found at Zeebrugge, E Patrouille *pers comm*), Varsenare (Hollevoet 2002, 168–73), Damme (In't Ven *et al* 2005)). It is not clear why this 3rd century 'native' tradition is influenced by Romano-British and other non-local stylistic, typological and decorative patterns. It is possible that the pottery industry was influenced and stimulated by the market created by a military presence in the region. It seems unlikely to be coincidental that this tradition began simultaneously with the establishment of forts (in the years AD 170–80 at Maldegem-Vake, Aardenburg and somewhat later at Oudenburg). It is also possible that Romanising influences increased, since the presence of military personnel would have provided more opportunities for trade and other personal contacts between Romano-British and Gallo-Romans providing an environment which enhanced the possibilities for exchange of material culture and ideas.

Chronology and functions reflected in the pottery

Samian from the Trier Massenfund (*c* AD 240–60), the Trier Louis-Linz-Strasse assemblage (*c* AD 260–75) and the Shadwell London watch-tower (*c* AD 250, Bird

NOM FR

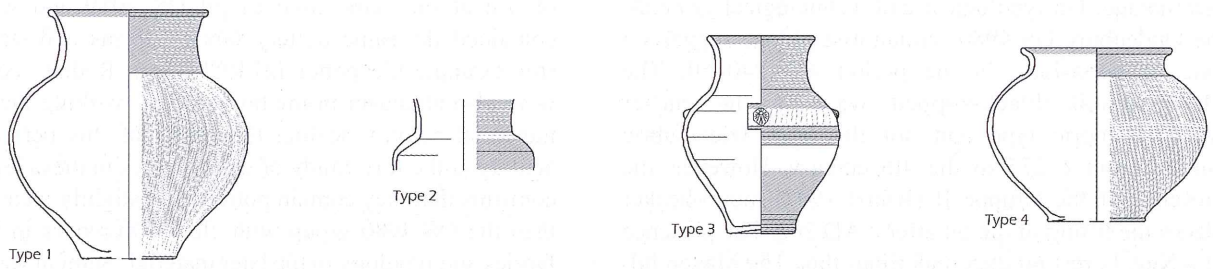

NOM RE

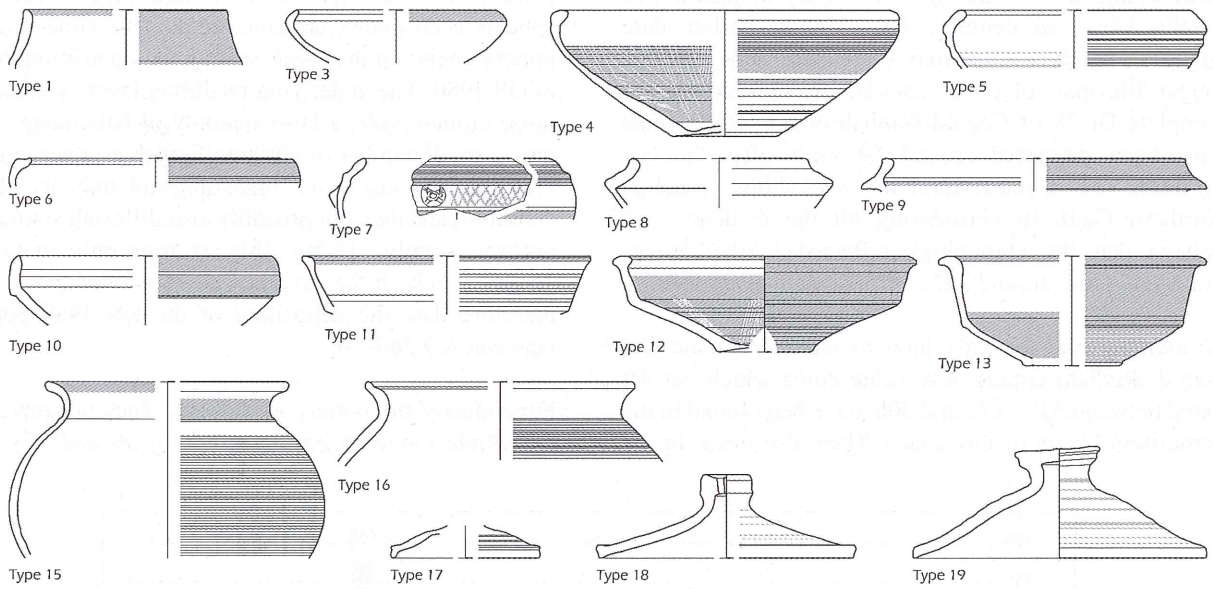

NOM HA

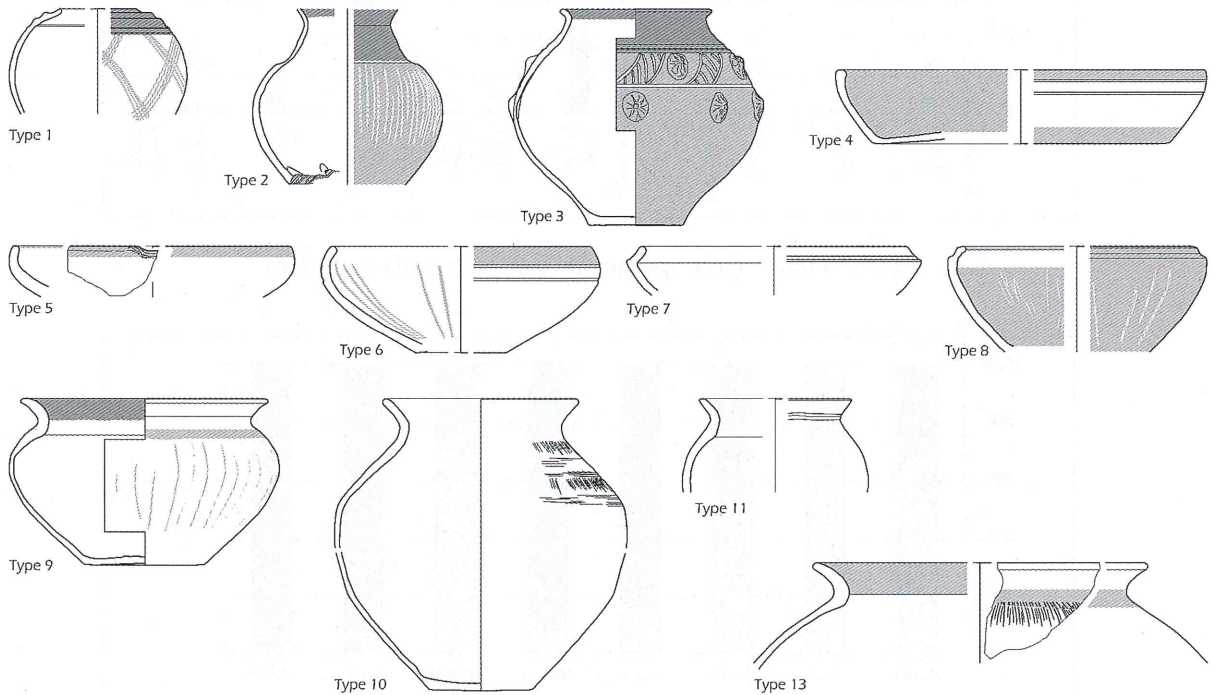

Fig 35: Pottery types present in NOM wares, light grey indicates burnished areas. Not to scale

2002) all offer distinctive parallels for the OS 4980 assemblage. On typological and technological grounds, the Oudenburg OS 4980 samian assemblage suggests a date of deposition in the period AD 240–60. The Moselkeramik black-slipped ware is the earlier sandwich-fabric type and not the later Trier fabric current from *c* 275 to the 4th century. However, the presence of the Gruppe II (Künzl 1997) motto-beaker places the filling of the pit after *c* AD 260. The presence of a New Forest product underlines this. The Mayen lid-seated jar in coarse oxidized ware of a form which seems to be a transition Niederbieber 89-Alzey 27 also points to the later 3rd century. The slightly earlier date suggested by the samian may be related to the possible longer life-span of these vessels, exemplified by the complete Dr 38 of Central-Gaulish origin, which must have been discarded around 50 years after the last products of Central-Gaulish workshops reached Northern Gaul. In considering all the evidence, we believe that the chronology reflected in the pottery indicates a date around AD 260 or shortly afterwards.

Stratigraphically the pit relates to the penultimate fort period. Radiate copies, low value coins which can be dated between AD *c* 275 and 300, have been found in the demolition layers of this phase. They also occur in the

demolition layers overlying a well which also went out of use at the same time as pit OS 4980 and which contained the same pottery fabrics, forms and stamps (for example the potter MERCUSSA). Radiate copies were also abundant in the burnt layers marking the last industrial activity sealing the layers of this period of activity at the fort. Study of the ceramics in these layers, confirms that they contain pottery of a slightly later date than the OS 4980 group with clear differences in both fabrics and typology in the later material. Samian ware is less well-represented, northern French products are present in larger quantities; a new flagon rim-type appears as do some Germanic sherds. This same range of pottery occurs in the levels sealing the deposition layers of OS 4980. The underlying pit-filling layers yielded far more samian ware, a large quantity of handmade ware, only a small number of northern French products and no Germanic pottery at all, indicating not only its earlier chronological date but probably also differing sources of pottery supply. Using this stratigraphic data, in conjunction with the ceramic and coin evidence we can therefore date the deposition of the OS 4980 pottery between AD 260–70.

Functionally the pottery assemblage does not represent the whole range of pottery use (Fig 36 and 37). The

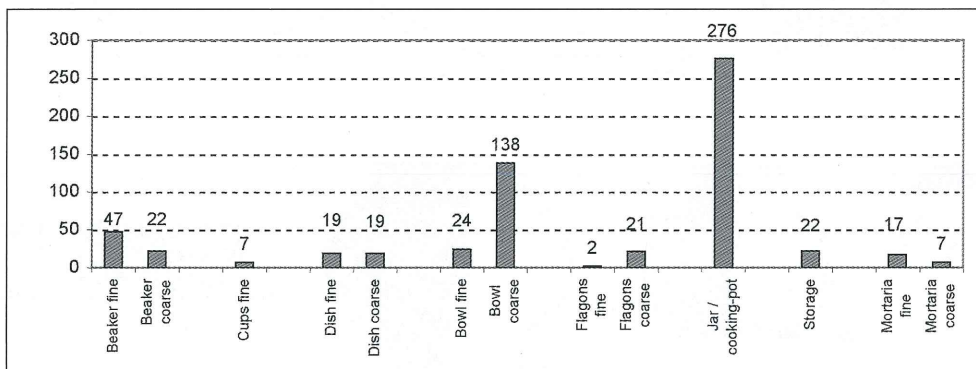

Fig 36: Pottery form types in fine and coarse fabrics by MNI

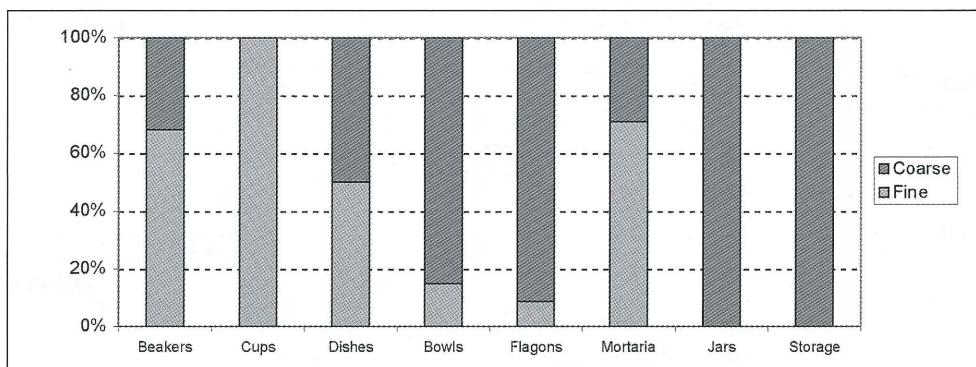

Fig 37: Proportional comparison of the functional pottery types in fine and coarse fabrics by MNI

majority of the assemblage is pottery for the preparation and consumption of food with cooking-pot/jars predominant. Surprisingly storage ware is hardly present. The small quantity of flagons is also remarkable and may relate to the military context or to changing (pottery/food/drinking) consumption patterns after the mid 3rd century. Tableware is well represented, but beakers in fineware are also sparse. Their function seems to have been taken over by beakers in handmade and fine reduced wares. The assemblage also gives new insights into the demand for samian in a later 3rd century context in Northern Flanders and sheds an important light on the later phases of production and export of samian from the Trier and Rheinzabern workshops. New potters have been identified, and an insight is provided on the trade mechanisms in operation at that time. Both production centres dominate the market in samian in equal proportions, but major functional differences can be seen; Trier is the provider of the majority of the dishes and mortaria while the Rheinzabern range of products was typologically more diverse.

Percentage of vessel types present (by MNI)

Jar/cooking pot	44 %
Bowls	26 %
Beakers	11 %
Dishes	6 %
Flagons	4 %
Storage	4 %
Mortaria	4 %
Cups	1 %

Historical context

The suggested date of *c* AD 260–70 for the pottery group OS 4980 and other contemporary structures seems to indicate important military activity during one or more periods of the Gallic Empire (AD 260–74). This secession empire was created in the aftermath of the capture of the Emperor Valerian by the Sassanid Persians in AD 260, when Postumus, commander of the Rhine armies took the opportunity to revolt, supported by legions based in Gaul, Spain and Britain (König 1981; Drinkwater 1987). Postumus and his successors (Laelianus, Marius, Victorinus, and Tetricus I and II) ruled the territory they controlled using the same procedures as the official Roman Empire, with a senate and two annually elected consuls.

On a number of occasions this Gallic Empire was invaded by Franks and *Alemanni*, mainly in landbased attacks, however according to several researchers, coin hoard finds show that there were also seaborne incursions. It has been suggested that the distribution and concentration of coin hoards in this period indicates the course of the invasions. Delmaire (1995) however questions the meaning of coin hoards as witnesses of

insecurity and pleads for a monetary theory. Kropff (2007) argues that political instability is a more likely explanation. Between AD 260 and 268 a high number of coin hoards were buried in north-western Gaul. Hoards dating to AD 260 have a strong concentration in the western provinces of Belgium and the north-western part of France to the Somme (Rogge 1996, 81), while hoards of AD 268 are mainly found in the coastal area of north-western Gaul (Gricourt 1988; Rogge 1996, 81; van Heesch 1998, 150).

Coins issued by Postumus also suggest there were seaborne Germanic attacks. To celebrate his military successes against these pirates, Postumus minted a series of different coin-types; coins with a galley and the legend *Laetitia Aug* ('good fortune of the Emperor') on the reverse, were minted in 261 AD (Gricourt 1988, 16 and 41; Elmer 1941, 130, 152–57, 186, 237–46), and to commemorate successes in AD 268, coin-types with a galley and the legend *Felicitas Temp* ('happiness/prosperous times') on the reverse were minted around the end of the summer of 268 AD (Gricourt 1988, 40–41; López Sánchez 2006, 40; Schulte 1983, 157–58).

Increasing archaeological data also seem to support the idea that in addition to naval activities in coastal waters, there were troop concentrations along the shores of northern Gaul. Undoubtedly the harbours along the coast of *Gallia Belgica* and *Germania Inferior* were secured. The Channel was the vital link between the Continent and Britain, and formed an important part of the Gallic Empire. The fleets at the disposal of the Gallic Emperors would have played a major role in protecting this link.

In an article 40 years ago about the Roman coins from the province of Zeeland (N), it was suggested that the north of Gaul had a coastal defence system (Boersma 1967, 76). Boersma noticed peaks in coin distributions from the period of the Gallic Empire at Aardenburg, Domburg and Schouwen (*ibid*, 70, 71, 76). Aardenburg is situated *c* 32 km to the east of Oudenburg at the end of a road starting at Oudenburg and passing through Bruges. Like Oudenburg, the Roman fortified site of Aardenburg was situated on a sandy ridge overlooking the Coastal Plain. Around AD 180 a playing-card shaped fort with sides 240x150m was built at Aardenburg defended by stone walls (Trimpe Burger 1973, 141–44). The occupation of the fort became civilian around AD 225 (Van Dierendonck 1987), but was probably re-occupied as a military camp during time of the Gallic Empire. Schouwen and Domburg are situated on either side of the estuary of the Oosterscheldt, which was the mouth of the Scheldt in Roman times. Domburg was probably an important site at this time since it had a temple dedicated to *Nehalennia* and other deities

(Hondius-Crone 1955). At Domburg and Schouwen the coin series show peaks of loss during the Gallic Empire, in particular during the years AD 268–73 (Boersma 1967, 70).

The fort at Oudenburg can now be added to the group of sites known to have had important activity during the Gallic Empire. Van Heesch noticed a peak of coin loss during the years AD 260–75 in coins from the J Mertens excavations at the Oudenburg fort (van Heesch 1998, 165). The recent excavations confirm this finding. In the latest layers of the penultimate fort period there are a huge quantity of radiate copies of Tetricus I and II and contemporaries (Dr J van Heesch now dates these imitations more generally to the period AD 275–300, *pers comm*).

This is not the only thing that Oudenburg has in common with the military site of Aardenburg. Research at Aardenburg has shown that it has levels with exactly the same pottery spectrum as the OS 4980 assemblage (Dhaeze *in prep*). Not only the pottery types, but also the fabrics are identical, indicating that both sites were supplied at the same time with the same products. The second sub-phase in this penultimate fort period, showing a slightly different pottery spectrum, is probably to be dated slightly later, around AD 270–80.

Conclusions

It seems that the military unit active at Oudenburg in the AD 260–70's under the reign of Postumus had access to supplies of pottery from a number of different production regions. Located on an access route to *Britannia*, the site benefited from and was obviously influenced by the commerce between *Britannia* and the continent. This is reflected in the large amount of samian, and also in the influences of the Romano-British industry such as the Black Burnished ware imports and the Black Burnished ware imitations in native handmade pottery. Although there was a large supply of imports, the regionally produced North Menapian Coarse Ware group, of both handmade and wheel-thrown variants, provided a major part of the pottery supply to the fort. This indicates that there must have been close contact between soldiers and civilians in the surrounding region and that this native industry was still a viable activity at a time when increasing political instability led to increased abandonment of civil rural sites. However, how the socio-economic pattern revealed from the OS 4980-group can be more fully understood on both a regional and inter-regional basis remains open for the moment. Further comparative research at Oudenburg and elsewhere will be needed to shed light on the socio-economic aspects reflected in the pottery groups of this historical important period at the mid-point between the earlier and later periods of the Roman era.

Acknowledgements

Sofie Vanhoutte is a researcher archaeology with the Flemish Heritage Institute (VIOE), Wouter Dhaeze an archaeologist with the City of Oudenburg completing a PhD and Wim De Clercq an assistant Lecturer at the Ghent University also completing a PhD. First of all they would like to thank Sylvia Mazereel and Franky Wyffels from the Flemish Heritage Institute for the many beautiful drawings. They also want to thank Dr Johan van Heesch (Coin Cabinet of the Royal Library of Belgium) for the identification of the coins, Joanna and David Bird, Brenda Dickinson and Ingeborg Huld-Zetsche for their valuable information on the Shadwell finds and for their comments on the stamped and decorated samian from Trier and Rheinzabern and to Malcolm Lyne, Paul Booth and Paul Tyers for providing information on Romano-British fabrics and pottery-types, Sonja Willems and Raphael Clotuche for comments on mortaria and North French Ware and Patrick Monsieur for some additional information about the Dressel 20 amphora. Marc Dewilde kindly provided them with his unpublished report on the Veurne handmade ware. They would also like to thank Hans Denis for the photographs of the pottery. The paper has been edited for publication in JRPS by Pamela V Irving and Steven Willis.

Bibliography

- Amand, M, 1984, *Vases à bustes, vases à décor zoomorphe et vases cultuels aux serpents dans les anciennes provinces de Belgique et de Germanie*, Bruxelles
- Batigne Vallet, C, 2001, Question de méthode concernant la céramique à feu: apports et limites de son étude, Le cas de Lugdunum, *Rei Cretariae Romanae Fautorum, Acta* 37, 37–44
- Baudoux, J, Bocquet, A, Brulet, R, Laubenheimer, F, Marlière, E, and Vilvorder, F, 1998, La production des amphores dans l'Est et le Nord des Gaules, Typologie et caractérisation physico-chimique, in Laubenheimer, F, (éd), *Les amphores en Gaul, 2, Production et circulation*, 11–48
- Bernhard, H, 1981, Zur Diskussion um die Chronologie Rheinzaberner Relieföpfer, *Germania* 59, 79–93
- Bird, J, 1986, Samian Wares, in Miller, L, Schofield, J, and Rhodes, M, (ed), *The Roman Quay at St Magnus House, London, Excavations at New Fresh Warf Lower Thames Street, London 1974–78*, Spec Pap 8 of the London and Middlesex Archaeol Society, 139–98
- Bird, J, 1993, 3rd century samian ware in Britain, *Jl of Roman Pottery Stud* 6, 1–14
- Bird, J, 2002, Samian wares, in Lakin, D, *The Roman Tower at Shadwell, London: a reappraisal*, MoLAS Archaeol Stud Ser 8, 31–48
- Bird, D, in press, The rest to some faint meaning make pretence, but Shadwell never deviates into sense (further speculation about the Shadwell 'tower')
- Bittner, F-K, 1986, Zur Fortsetzung der Diskussion um die Chronologie der Rheinzaberner Relieföpfer, *Bayerische Vorgeschichtsblätter* 51, 233–59
- Boersma, J S, 1967, The Roman coins from the province of Zeeland, *Berichten van de Rijksdienst voor het Oudheidkundig Bodemonderzoek* 17, 65–97
- Bouche, K, and Michel, K, 2004, Pitgam-Schulleveldt, Station de recompression et tranchée du gazoduc, Site d'habitat et

- d'artisanat, réseaux fossoyé d'époque romaine, in De Saulce, A, (ed), *Les fouilles du gazoduc Artère des Hauts de France*, Revue du Nord, Coll Art et Archéologie **9**, 35–71
- Brulet, R, Bocquet, A, and Laduron, D, 1994, Mise en évidence d'un groupe de céramiques dérivées de terre sigillée tardive dans le nord-ouest de la Gaule, *Acta Archaeologica Lovaniensia* **33**, 7–50
- Brulet, R, Symonds, R, and Vilvorder, F, (eds), 1999, *Céramiques engobées et métallescentes gallo-romaines*, Rei Cretariae Romanae Fautorum, Acta -Sup **8**, Oxford
- Brulet, R, Misonne, B, and Feller, M, 2000, La terre sigillée tardive et ses dérivées dans le nord de la Gaule, in Strobel, K, (ed), *Forschungen zur römischen Keramikindustrie, Produktions-, Rechts- und Distributionsstrukturen, Akten des 1 Trierer Symposiums zur antiken Wirtschaftsgeschichte*, Trierer historische Forschungen **42**, Mainz, 219–33
- Brulet, R, and Vilvorder, F, (ed), 2004, *La céramique culturelle et le rituel de la céramique en Gaule du Nord, Catalogue d'exposition publié à l'occasion du 24e Congrès Int des Rei Cretariae Romanae Favtores (Moulin de Beez, 27 Sept–15 Oct 2004)*, Coll d'archéologie Joseph Mertens **15**, Louvain-la-Neuve
- Chenet, G, 1941, *La céramique gallo-romaine d'Argonne au 4e siècle et la terre sigillée décorée à la molette*, Fouilles et documents d'Archéologie Antique en France, tome **1**, Mâcon
- Creus, I, 1975, *De Gallo-Romeinse nederzetting onder het laat-Romeinse grafveld van Oudenburg*, Archaeol Belgica **179**, Brussel
- Creuzenet, F, 1996, Sigillée, parois fines et métallescentes produites en Bourgogne, *Soc Française d'Étude Céramique Antique en Gaule, Congrès de Dijon*, 81–97
- De Clercq, W, 1995, Enkele opmerkelijke Gallo-Romeinse vondsten uit Merendree, bewaard in de Koninklijke Musea voor Kunst and Geschiedenis te Brussel, *Bull van de Koninklijke Musea voor Kunst and Geschiedenis te Brussel* **66**, 151–59
- De Clercq, W, 2005, Shaped by tradition, On the persistence of pre-Roman pottery traditions in northern Gaul, *Rei Cretaria Romanae Fautores Acta* **3**, 201–8
- De Clercq, W, in prep, PhD research
- De Clercq, W, and Degryse, P, 2008, Mineralogical characterization and first identification of the Low Lands Ware 1, An important Roman ceramic industry in the lower Rhine-Meuse-Scheldt basin (cAD 60–300), The Netherlands, Belgium, Germany, *J Archaeol Science* **35**, 448–58
- De Clercq, W, and Deschieter, J, 2002, *Quelques remarques sur la diffusion de la terre sigillée dans le civitas Menapiorum au cours de l'Haut Empire*, in Première Journée Archéologique des Flandres, Bailleul, Conseil Général du Nord, 35–45
- De Clercq, W, Eryvncq, A, Lentacker, A, Mortier, S, Tency, H, and Van Strydonck, M, 2005, De protohistorische periode uit de opgravingen te Aalter, industrieterrein Langevoorde, Profane en rituele aspecten uit de late IJzertijd, *Lumula, Archaeol Protohistorica*, **13**, 125–34
- De Laet, S J, and Thoen, H, 1969, Etudes sur la céramique de la nécropole gallo-romaine de Blicquy (Hainaut), *Helinium* **9**, 28–38
- De Mulder, G, and Deschieter, J, 2003, Het preventief onderzoek in de Gallo-Romeinse vicus te Velzeke (2001–2), Een archeologisch vervolgverhaal, *Archeologische Kroniek van Zuid-Oost-Vlaanderen, Bijdragen* **8**, Zottegems Genootschap voor Geschiedenis en Oudheidkunde, Handelingen **11**, 259–94
- De Wilde, M, and Verhaeghe, F, *Het Romeinse en middeleeuwse aardewerk van Wulpen-Steendam*, unpublished report (1988).
- Delmaire, R, 1995, Les enfouissements monétaire, témoignages d'insécurité?, *Revue du Nord – Archéologie* **77**, 313, 21–26
- Deru, X, 1996, *La céramique Belge dans le Nord de la Gaule, Caractérisation, Chronologie, Phénomènes Culturels et Economiques*, Pub d'Histoire de l'Art et d'Archéol de l'Université Catholique de Louvain-La-Neuve, **89**
- Deru, X, 2005, Les productions de l'atelier de potiers des 'Quatre Bornes' aux Rues-des-Vignes (Nord), *Soc Française d'Étude Céramique Antique en Gaule, Actes du Congrès de Blois*, 469–77
- Desbat, A, and Vilvorder, F, 2000, Die Trierer Schwarzfirnisware: produktion und Handel, in Strobel, K, (ed), *Forschungen zur römischen Keramikindustrie, Produktions-Rechts- und Distributionsstrukturen*, Trierer Historische Forschungen **42**, Mainz, 178–91
- De Visser, N, 2001, *Hof van Buize 2 te Aardenburg, Studie van het Romeinse materiaal en sporen aangetroffen op het perceel Hof van Buize 2 bij opgravingen in 1998, Band 1, 2 en 3*, onuitgegeven licentiaatsverhandeling UGent, Gent
- Dhaeze, W, and Seillier, C, 2005, La céramique de l'égout collecteur du camp de la Classis Britannica à Boulogne-sur-Mer (Pas-de-Calais), *Soc Française d'Étude Céramique Antique en Gaule, Actes du Congrès de Blois*, 609–38
- Dhaeze, W, in prep, PhD research
- Dierendonck, R M, van, 1987, The Roman wall-paintings and the character of the Roman settlement at Aardenburg (The Netherlands), in *Aventicum 5, Pictores per provincias*, Cahiers d'archéologie Romande **43**, 197–99
- Drinkwater, J F, 1987, *The Gallic Empire, Separatism and continuity in the north-western provinces of the Roman Empire AD 260–74*, Historia, Einzelschriften Heft **52**, Stuttgart
- Elmer, G, 1941, *Die Münzprägung der gallischen Kaiser in Köln, Trier und Mailand*, Bonner Jahrbüch **146**, 1–106
- Florent, G, and Cabal, M, 2004, La céramique gallo-romaine d'Ardres (Pas-de-Calais), *Revue du Nord, Archéologie de la Picardie et du Nord de la France*, tome **86**, 358, 53–111
- Fölzer, E, 1913, *Die Bilderschüsseln der Ostgallischen Sigillata-Manufakturen*, Römischen Keramik in Trier **1**, Bonn
- Frey, M, 2000, *Die letzten Reliefsigillaten aus Trier und ihre Zeitstellung*, in Strobel, K, (ed), *Forschungen zur römischen Keramikindustrie, Produktions-, Rechts- und Distributionsstrukturen, Akten des 1, Trierer Symposiums zur antiken Wirtschaftsgeschichte*, Trierer historische Forschungen **42**, Mainz, 209–18
- Frey, M, 2001, *Die terra Sigillata der gallorömischen Villenanlage bei Borg, Landkreis Merzig-Wadern*, Bericht der Staatlichen Denkmalpflege im Saarland Abteilung Bodendenkmalpflege, Beiheft **5**, Saarbrücken
- Fulford, M G, 1975, *New Forest Roman Pottery*, British Archaeol Rep, British Ser **17**, Oxford
- Fulford, M, and Bird, J, 1975, Imported pottery from Germany, *Britannia* **6**, 171–81
- Gilles, K-J, 1994, Ateliers de céramiques du Bas-Empire dans la vallée de la Moselle et l'Eifel, in Tuffreau-Libre, M, and Jacques, A, *La céramique du Bas-Empire en Gaule Belgique et dans les régions voisines, Actes de la table ronde de céramologie gallo-romaine, Arras, 8–10 oct 1991*, 117–25
- Gilté, M, 1993, *Het Gallo-Romeins aardewerk uit de zuidoostelijke zone van de vicus te Oudenburg, Delen 1, 2, 3, 4 en 5*, onuitgegeven licentiaatsverhandeling UGent, Gent
- Gose, E, 1950, *Gefässtypen der römischen Keramik im Rheinland*, Bonner Jahrbüch, Beiheft **1**, Köln
- Gricourt, D, 1988, Les incursions de pirates de 268 en Gaule septentrionale et leurs incidences sur la politique de Postume, *Trésors monétaires* **10**, 9–43
- Hannois, Ph, 1996, Prospections à Steene-Pitgam: répertoire céramique ménapien et données nouvelles sur la fabrication du sel, *Revue Du Nord-Archéologie* **333**, 107–19
- Haupt, D, 1984, Römischer Töpferbezirk bei Soller, Kreis-Düren, in Haupt, D, (ed), *Beiträge zur Archäologie des Römischen Rheinlands* **4**, Rheinische Ausgrabungen **23**, 391–497
- Herbin, P, 2002, Les vases à éléments de préhension dans le nord de la Gaule, *Soc Française d'Étude Céramique Antique en Gaule, Actes du congrès de Bayeux*, 417–30
- Holbrook, N, and Bidwell, P T, 1991, *Roman finds from Exeter*, Exeter Archaeol Rep **4**, Exeter

- Hollevoet, Y, 1989, Archeologisch noodonderzoek in de Zeebrugse achterhaven: de Romeinse vondsten, *Westvlaamse Archaeol* 5, 33–48
- Hollevoet, Y, 1992, Sporen onder het sportveld, Romeinse en middeleeuwse sporen ten zuiden van de Stedebeek te Oudenburg (prov. West-Vlaanderen), Interimverslag 1990–92, *Archeologie in Vlaanderen* 2 (for 1993), 195–207
- Hollevoet, Y, 1993, Ver(r)assingen in een verkaveling, Romeins grafveld te Oudenburg (prov. West-Vlaanderen), Interimverslag, *Archeologie in Vlaanderen* 3 (for 1994), 207–16
- Hollevoet, Y, 2002, D'Hoogne Noene te Varsenare van midden Bronstijd tot volle Middeleeuwen, Archeologisch onderzoek in een verkaveling langs de Zandstraat te Varsenare (gem. Jabbeke, prov. West-Vlaanderen), *Archeologie in Vlaanderen* 4 (for 1997/1998), 161–89
- Hondius-Crone, A, 1955, *The temple of Nehalennia at Domburg*, Amsterdam
- Huld-Zetsche, I, 1971, Glatte Sigillaten des 'Massenfunds' aus Trier, *Rei Cretariae Romanae Fautorum Acta* 13, 21–39
- Hull, M R, 1963, *The Roman Potters' Kilns of Colchester*, Rep of the Research Committee of the Society of Antiquaries of London 21, Oxford
- In't Ven, I, and Hollevoet, Y, 2005, Brugge-Dudzele, Landslag-Oost 1, in In't Ven, I, and De Clercq, W, (eds), *Een lijn door het landschap. Archeologie en het vTn project 1997–98, Deel I*, Archeologie in Vlaanderen, Mono 5, Brussel, 43–45
- In't Ven, I, Hollevoet, Y, Cooremans, B, De Grootte, A, and Deforce, K, 2005, Romeinse bewoning aan de Antwerpse Heirweg in Sijsele-Damme, in In't Ven, I, and De Clercq, W, (eds), *Een lijn door het landschap. Archeologie en het vTn project 1997–98, Deel I*, Archeologie in Vlaanderen, Mono 5, Brussel, 47–76
- Ikäheimo, J P, 2003, *Late Roman African Cookware of the Palatine East Excavations, Rome, A holistic approach*, British Archaeol Rep, Internat Ser 1143, Oxford
- Johns, C, 1963, Black Samian from South-Wales, *Monmouthshire Antiq* 1, 58–66
- Ketels, J, 2001, L'officine de potiers de la Caloterie (Pas-de-Calais), 1er s.-début du 4e siècle apr. J.-C., *Soc Française d'Étude Céramique Antique en Gaul, Actes du Congrès de Lille-Bavay*, 141–49
- König, I, 1981, *Die gallischen Usurpatoren von Postumus bis Tetricus*, Vestigia, Beiträge zur alten Geschichte Band 32, München
- Kortüm, K, 1995, *Portus Pforzheim, Untersuchungen zur Archäologie und Geschichte*, Quellen u, Studien z, geschichte der Stadt Pforzheim 3, Sigmaringen
- Kropff, A, 2007, Late Roman coin hoards in the West: trash or treasure?, *Revue belge de numismatique et de sigillographie* 153, 73–86
- Künzl, S, 1997, *Die Trierer Spruchbecherkeramik, Dekorierter Schwarzfirnisware des 3. und 4. Jahrh n Chr* Trierer Zeitschrift, Beiheft 21, Trier
- Laubenheimer, F, 1990, *Le temps des amphores en Gaule. Vins, huiles et sauces*, Paris.
- Loeschke, S, 1921, Töpfereiabfall dJ 259/260 in Trier: Aus einer römischen Grube and der Louis-Linz-Strasse, *Trierer Jahresberichten, Beilage 2, NF* 13
- López Sánchez, F, 2006, La série légionnaire de Victorin et ses emblèmes *ad hoc*, in Hollard, D, (ed), *L'armée et la monnaie, Actes de la journée d'études de 10 déc 2005 à la Monnaie de Paris*, Rech et Travaux de la Soc d'Études Numismatiques et Archéologiques 1
- Ludowici, W, 1912, *Römische Ziegel-Gräber, Katalog 4 Meiner Ausgrabungen in Rheinzabern 1908–12, Stempel-Namen, Stempel-Bilder, Urnen-Gräber*, München
- Mertens, J, 1977, Oudenburg and the northern sector of the continental Litus Saxonicum, in Johnston, D E (ed), *The Saxon Shore*, Coun British Archaeol Res Rep 18, 51–62
- Mertens, J, 1980, Recherches récentes sur le limes en Gaule Belgique, in Hanson, W S, and Keppie, L J F, (eds), *Pap pres to the 12th Internat Congress of Roman Frontier Stud*, British Archaeol Rep, Internat Ser 71.i, 423–70
- Mertens, J, 1987, *Oudenburg, Romeinse legerbasis aan de Noordzeekust, (tweede aangevulde uitgave verzorgd door R. Crabbé)*, Archaeol Belgii Speculum 4, Brussel
- Mertens, J, and Van Impe, L, 1971, *Het laat-Romeins grafveld van Oudenburg*, Archaeol Belgica 135, Brussel
- Mostaert, F, 2000, Geografische situering en ontwikkeling van de Vlaamse kuststreek, *Vlaanderen* 49/3, 2–6
- Oelmann, F, 1914, *Die Keramik des Kastells Niederbieber*, Materialien zur römisch-germanischen Keramik 1, Frankfurt am Main
- Oswald, E, and Pryce, D T, 1920, *An Introduction to the Study of Terra Sigillata (Samian Ware)*, Margidunum.
- Oswald, F, 1931, *Index of Potters' Stamps on Terra Sigillata (Samian Ware)*, Margidunum
- Peacock, D P S, 1977a, Ceramics in Roman and Medieval Archaeology, in Peacock, D P S, (ed), *Pottery and Early Commerce, Characterisation and Trade in Roman and Later Ceramics*, London/New York/San Francisco, 21–33
- Peacock, D P S, 1977b, Pompeian Red Ware, in Peacock, D P S, (ed), *Pottery and Early Commerce, Characterisation and Trade in Roman and Later Ceramics*, London/New York/San Francisco, 147–62
- Peacock, D P S, and Williams, D F, 1986, *Amphorae and the Roman economy, an introductory guide*, London/New York
- Pearson, A, 2002, *The Roman Shore Forts, Coastal Defences of Southern Britain*, Charleston
- Pferdehirt, B, 1976, *Die römischen Keramik des Kastells Holzhausen*, Limesforschungen 16
- Pirling, R, 1974, *Das römisch-fränkische Gräberfeld von Krefeld-Gellep 1963–1966*. Germanische Denkmäler der Völkerwanderungszeit Serie B, Die Fränkischen Altertümer des Rheinlandes 8, Berlin
- Redknap, M, 1988, Medieval Pottery Production at Mayen: Recent Advances, Current Problems, in Gaimster, D R M, Redknap, M, Wegner, H-H, (eds), *Zur Keramik des Mittelalters und der beginnenden Neuzeit im Rheinland, Medieval and later pottery from the Rhineland and its markets*, British Archaeol Rep, Internat Ser 440, 3–37
- Redknap, M, 1999, *Die römischen und mittelalterlichen Töpfereien in Mayen, Kreis Mayen-Koblenz*, in Wegner, H-H, (ed), *Berichte zur Archäologie an Mittelrhein und Mosel* 6, *Trierer Zeitschrift* 24, 11–401
- Reuter, S, 2005, Ein Zerstörungshorizont der Jahre um 280 n. Chr. in der Retentura des legionenslager Reginum/Regensburg, Die Ausgrabungen in der Gragasse-Maximilianstrasse 26 in den Jahren 1979/80, *Bayerische Vorgeschichtsblätter* 70, 183–281
- Richardson, B, 1986, Pottery, in Miller, L, Schofield, J, and Rhodes, M, (eds), *The Roman Quay at St Magnus House, London, Excavations at New Fresh War, Lower Thames Street, London 1974–78*, Spec Pap 8, London and Middlesex Archaeol Soc, 96–138
- Ricken, H, and Fisher, Ch, 1963, *Die Bilderschüsseln der Römischen Töpfer von Rheinzabern*, Text, Materialien zur Römisch-Germanischen Keramik Heft 7, Bonn
- Rogge, M, 1996, Vlaanderen en het zuiden van Nederland weken zich los van het centrum (van Postumus tot Carinus, 260–85), in Lamarq, D, and Rogge, M, (red), *De taalgrens, Van de oude tot de nieuwe Belgen*, Leuven, 68–98
- Roumegoux, Y, and Termote, J, 1993, *Op de rand van een imperium, De Romeinen in de Westhoek*, in Roumegoux, Y, and Termote, J, (eds), *Kemmel-Cassel, De vroegste bewoningsgeschiedenis van de Vlaamse heuvels*, *Westvlaamse Archaeol* 9, 2, 61–85
- Scholz, M, 2006, Keramik und Geschichte des Limeskastell Kapersburg. Eine Bestandsaufnahme, *Saalburg Jahrbuch* 52/53, (for 2002–3), 9–228

- Schulte, B, 1983, *Die Goldprägung der gallischen Kaiser von Postumus bis Tetricus*, Typos 4, Aarau/Frankfurt am Main/Salzburg
- Simon, H-G, 1968, *Das Kleinkastell Degerfeld in Butzbach, Kr. Friedbach (Hessen). Datierung und Funde*, Saalburg Jahrbuch 25, 5–64
- Simon, H-G, and Köhler, H-J, 1992, *Ein Geschirrdépôt des 3. Jahrhunderts, Grabungen im Lagerdorf des Kastells Langenhain*, Materialien zur Römisch-Germanischen Keramik, Heft 11
- Simpson, G, 1973, More black slip vases from Central Gaul with applied and moulded decoration in Britain, *Antiq J* 53, 42–51
- Stamm, O, 1962, *Spätromische und frühmittelalterliche Keramik der Altstadt Frankfurt am Main*, Schriften des Frankfurter Museums für Vor- und Frühgeschichte 1
- Symonds, R P, 1992, *Rhenish Wares: fine dark coloured pottery from Gaul and German*, Oxford Univ Comm for Archaeol, Mono 23
- Symonds, R P, and Haynes, I, 2007, Developing methodology for inter-provincial comparison of pottery assemblages, in Hingley, R, and Willis, S, (eds), *Roman finds: context and theory, Proc Conf at the Univ of Durham*, Oxford, 67–76
- Symonds, R P, and Wade, S, 1999, *Roman pottery from excavations in Colchester, 1971–86*, Colchester Archaeol Rep 10, Colchester
- Thoen, H, 1978, *De Belgische Kustvlakte in de Romeinse tijd, Bijdrage tot de studie van de landelijke bewoningsgeschiedenis*, Verhandelingen van de Koninklijke Academie voor Wetenschappen, Letteren en Schone kunsten van België Klasse der Letteren 40, 88, Brussel
- Thuillier, F, 2001, L'atelier céramique d'époque gallo-romaine de Dourges (Pas-de-Calais, France), Aperçu des structures et de la production, *Rei Cretariae Romanae Fautorum, Acta* 37, Abingdon, 127–132
- Tomber, R, and Dore, J, 1998, *The National Roman Fabric Reference Collection, A Handbook*, MoLAS, Mono 2
- Trimpe Burger, J-A, 1973, The Islands of Zeeland and South Holland in Roman times, *Berichten van de Rijksdienst voor het Oudheidkundig Bodemonderzoek* 23, 135–48
- Trimpe Burger, J-A, 1995, *Brabers bij Haamstede (provincie Zeeland)*, Archief van het Koninklijk Zeeuwsch Genootschap der Wetenschappen, 1–58
- Trimpe Burger, J-A, 1997, *De Romeinen in Zeeland, Onder de hoede van Nehalennia*, Goes
- Tuffreau-Libre, M, 1980, *La céramique commune gallo-romaine dans le nord de la France (Nord, Pas-de-Calais)*, Lille
- Tuffreau-Libre, M, Mossman-Bouquillon, A, and Symonds, R P, 1995, La céramique dite black-burnished dans le nord de la Gaule, *Soc Française d'Étude Céramique Antique en Gaule, Actes du congrès de Rouen, 25–28 mai 1995*, 91–112
- Tyers, P, 1999, *Roman pottery in Britain*, London/New York
- Unverzagt, W, 1968, *Die Keramik des Kastells Alzei*, Materialien zur Römisch-Germanischen Keramik, Heft 2, Bonn
- Van Der Werff, J, Thoen, H, and Van Dierendonck, R, 1997, Amphora production in the Lower Scheldt Valley (Belgium)? The Valkenburg-Marktveeld evidence, *Rei Cretariae Romanae Fautorum, Acta* 35, Abingdon, 63–71
- Van Enckevort, H, 2004, *Het gedraaide aardewerk uit de Romeinse tijd*, in Koot, C W, and Berkvens, R (eds), *Bredase akkers eeuwenoud, 4000 jaar bewoningsgeschiedenis op de rand van zand en klei*, Erfgoedstudies Breda 1, 281–358
- Van Heesch, J, 1998, *De muntcirculatie tijdens de Romeinse tijd in het noordwesten van Gallia Belgica, De civitates van de Nerviiërs en de Menapiërs (c 50 v C–450 nC)*, Koninklijke Musea voor Kunst en Geschiedenis, Mono van Nationale Archeol 11, Brussel
- Van Heesch, J, and Deschietter, J, 2000, *De Gallo-Romeinse vicus te Velzeke 2, Een muntschat uit de tijd van keizer Postumus*, Pub van het provinciaal Archeol Mus van Zuid-Oost-Vlaanderen, site Velzeke, Gewone Reeks 3
- Vanhoutte, S, 2007, Het Romeinse castellum van Oudenburg (prov West-Vlaanderen) herontdekt: de archeologische campagne van augustus 2001 tot april 2005 ter hoogte van de zuidwesthoek, Interim-rapport, *Relicta, Archeol, Monumenten-en Landschapsonderzoek in Vlaanderen* 3, 199–236
- Vanhoutte, S, and De Clercq, W, 2007, Het Gallo-Romeins aardewerk aangetroffen tijdens het archeologisch noodonderzoek op het toekomstige bedrijventerrein Plassendale III. Opgravingscampagne 2000–2001 (Zandvoorde, stad Oostende, prov, West-Vlaanderen), *Relicta, Archeol, monumenten-en landschapsonderzoek in Vlaanderen* 1, 81–119
- Vanhoutte, S, Bastiaens, J, De Clercq, W, Deforce, K, Eryvynck, A, Fret, M, Haneca, K, Lentacker, A, Stieperaere, H, Van Neer, W, Cosyns, P, Degryse, P, Dhaeze, W, Dijkman, W, Lyne, M, Rogers, P, van Driel-Murray, C, van Heesch, J and Wild, J P, (in press), De dubbele waterput uit het laat-Romeinse castellum van Oudenburg: tafonomie, chronologie en interpretatie, *Relicta, Archeol, Monumenten-en Landschapsonderzoek in Vlaanderen* 5
- Vanvinckenroye, W, 1991, *Gallo-Romeins aardewerk van Tongeren*, Pub van het Provinciaal Gallo-Romeins mus te Tongeren 44, Tongeren
- Vermeulen, F, 1992, *Tussen Leie en Schelde, Archeologische Inventaris en studie van de Romeinse bewoning in het zuiden van de Vlaamse Zandstreek*, Archeol Inventaris Vlaanderen, Buitengewone Reeks 1
- Willems, S, 2000, *Mortaria van de site Zijdellingestraat, Tienen: Macroscopische analyse en determinatie van de baksels*, ongepubliceerde licentiaatsverhandeling KULeuven, Leuven
- Willems, S, 2005, *Roman pottery in the Tongeren reference collection: mortaria and coarse ware/Romeins aardewerk in de Tongerse referentiecollectie: wrijfschalen en gewoon aardewerk*, VIOE-Rapporten 01, Brussel