



Kent Academic Repository

Casson, Alexander J., Vazquez Galvez, Arturo and Jarchi, Delaram (2016) *Gyroscope vs. accelerometer measurements of motion from wrist PPG during physical exercise*. ICT Express, 2 (4). pp. 175-179. ISSN 2405-9595.

Downloaded from

<https://kar.kent.ac.uk/69648/> The University of Kent's Academic Repository KAR

The version of record is available from

<https://doi.org/10.1016/j.ict.2016.11.003>

This document version

Publisher pdf

DOI for this version

Licence for this version

CC BY-NC-ND (Attribution-NonCommercial-NoDerivatives)

Additional information

Versions of research works

Versions of Record

If this version is the version of record, it is the same as the published version available on the publisher's web site. Cite as the published version.

Author Accepted Manuscripts

If this document is identified as the Author Accepted Manuscript it is the version after peer review but before type setting, copy editing or publisher branding. Cite as Surname, Initial. (Year) 'Title of article'. To be published in *Title of Journal*, Volume and issue numbers [peer-reviewed accepted version]. Available at: DOI or URL (Accessed: date).

Enquiries

If you have questions about this document contact ResearchSupport@kent.ac.uk. Please include the URL of the record in KAR. If you believe that your, or a third party's rights have been compromised through this document please see our [Take Down policy](https://www.kent.ac.uk/guides/kar-the-kent-academic-repository#policies) (available from <https://www.kent.ac.uk/guides/kar-the-kent-academic-repository#policies>).

Gyroscope vs. accelerometer measurements of motion from wrist PPG during physical exercise[☆]

Alexander J. Casson^{*}, Arturo Vazquez Galvez, Delaram Jarchi

School of Electrical and Electronic Engineering, The University of Manchester, Manchester, UK

Received 26 September 2016; received in revised form 25 November 2016; accepted 28 November 2016

Available online 6 December 2016

Abstract

Many wearable devices include PPG (photoplethysmography) sensors for non-invasive heart rate monitoring. However, PPG signals are heavily corrupted by motion interference, and rely on simultaneous motion measurements to remove the interference. Accelerometers are used commonly, but cannot differentiate between acceleration due to movement and acceleration due to gravity. This paper compares measurements of motion using accelerometers and gyroscopes to give a more complete estimate of wrist motion. Results show the two sensor signals are very different, with low correlations present. When used in a wrist PPG heart rate algorithm gyroscope motion estimates obtain better performance in half of the cases.

© 2016 The Korean Institute of Communications Information Sciences. Publishing Services by Elsevier B.V. This is an open access article under the CC BY-NC-ND license (<http://creativecommons.org/licenses/by-nc-nd/4.0/>).

Keywords: Photoplethysmography (PPG); Gyroscope; Accelerometer; Heart rate monitoring; Physical exercise

1. Introduction

Very long term portable heart rate monitoring is quickly emerging as one of the leading uses of wearable technology. Most smart watches, including the Apple Watch, Samsung Gear S2, and Fitbit Surge include a heart rate monitor which can be used for optimizing workouts [1] and potentially for automatically detecting serious events such as atrial fibrillation [2]. As such they are enabling the study of heart function in the general population in a way not possible with traditional Holter monitors and they are seen as an important part of future personalized and preventative healthcare. It is estimated that 80% of heart diseases and 70% of strokes could be avoided with suitable preventative techniques [3].

These monitors are based upon Photoplethysmography (PPG), which shines a light into the wrist and measures the amount of light reflected back, which changes with blood flow.

Unlike the Electrocardiogram (ECG) the PPG does not require a sticky conductive gel based electrode and so is highly suited to wearable applications. However, PPG signals are significantly corrupted by artifacts due to physical activity which have historically limited PPG to relatively motion free clinical settings [4]. Today, several different signal processing methods have been proposed for removing the interference, allowing heart rate to be extracted in the presence of motion. Nevertheless, in practical use the performance of these methods is still under investigation [5].

Recently many different motion artifact removal algorithms have been proposed based upon the 2015 ‘IEEE Signal Processing cup’ [6,7]. This provided a database of: wrist PPG; co-located 3-axis accelerometer measurements to give a reference recording of wrist motion; and a chest ECG to give a gold standard comparison of the subject’s heart rate; for 23 subjects. As a result, many algorithms are based upon using the accelerometer signal as a reference of the motion present, and subtracting it in some way from the PPG trace, for example by using an adaptive filter [6]. While 3-axis accelerometers have been widely applied in fitness trackers, as they measure acceleration they do not give a complete picture of the movement of the wrist and PPG sensor node. In particular, accelerometers alone cannot differentiate between acceleration components due to movement of the

^{*} Corresponding author.

E-mail address: alex.casson@manchester.ac.uk (A.J. Casson).

Peer review under responsibility of The Korean Institute of Communications Information Sciences.

[☆] This paper is part of a special issue titled Special Issue on Emerging Technologies for Medical Diagnostics guest edited by Ki H. Chon, Sangho Ha, Jinseok Lee, Yunyoung Nam, Jo Woon Chong and Marco DiRienzo.

Table 1
Summary of exercises performed by each subject. Green = Subject did that activity, Red = Subject did not.

Subject	Walk	Run	Low resistance bike (lrb)	High resistance bike (hrb)
1	Green	Red	Green	Green
2	Green	Red	Green	Green
3	Green	Red	Green	Green
4	Red	Green	Red	Red
5	Red	Green	Red	Red
6	Green	Green	Red	Red
8	Green	Red	Red	Red
9	Green	Red	Red	Red

subject/sensor and acceleration components due to gravity. Using accelerometers in isolation thus gives only a partial estimate of the true motion present.

We propose that this can be overcome by using co-located gyroscopes in addition to the co-located accelerometers. Results from fitness trackers have shown how this combination of sensors can extract both the orientation and angular velocity of the sensor node [8,9]. However, to our knowledge, gyroscope information has not yet been used in algorithms for estimating PPG based heart rate during physical activity. We have recorded a new database of wrist based PPG measurements which include both a 3-axis accelerometer and a 3-axis gyroscope while participants walk, run and cycle. In this article we characterize the gyroscope information and compare it to that collected by the accelerometers, demonstrating the potential use of gyroscopic data for improving the performance of future algorithms.

2. Methods

2.1. Data collection

PPG recordings were collected from 8 subjects for approximately 5 min each as they undertook a range of physical exercise activities on a treadmill and exercise bike, different for each person as detailed in Table 1.

PPG and motion were recorded using a Shimmer 3 GSR+ [10], with 3-axis gyroscope, 3-axis low noise (± 2 g) accelerometer, 3-axis wide range (± 16 g) accelerometer, and PPG input. A green LED PPG sensor was glued to the main Shimmer unit to give a rigid connection and allow the accelerometers and gyroscopes inside the Shimmer unit to accurately record the movement of the PPG sensor. The combined unit was connected to the wrist using a continuously adjustable strap (similar to the Scosche Rhythm+ [11]), see Fig. 1. All of the signals (including a simultaneous ECG for gold standard heart rate) have been made public: <https://physionet.org/works/WristPPGduringexercise/>. Note in Table 1 (and Table 3) there is no subject 7 as this data was not shared publicly.



Fig. 1. PPG unit set up.

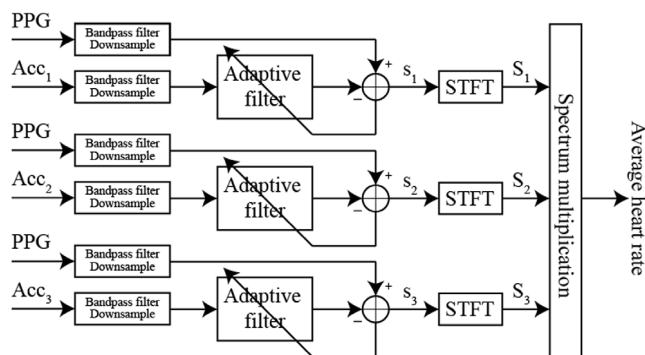

Fig. 2. PPG heart rate estimation algorithm. Acc_x is (accelerometer/gyroscope) input on axis x .

2.2. Signal comparison

For comparing the accelerometer and gyroscope recordings of motion we first present a range of example signals, showing visually the different captures of motion provided. These are considered in both the time and frequency domain, using a standard FFT applied to the data sections. The results are quantified by considering the correlations present between the different motion signals (3-axes of accelerometer data and 3-axes of gyroscope data), demonstrating that across all of the records the accelerometer and gyroscope consistently collect different information.

Finally we use the gyroscope data in a PPG heart rate extraction algorithm, comparing the performance of the algorithm when the recorded motion input comes from the accelerometers and from the gyroscopes. Our algorithm is described in detail in [12], and overviewed in Fig. 2 where the Acc input is either the accelerometer or the gyroscope depending on the test case. The method is similar to that in [13] using a normalized least mean squared adaptive filter to remove motion interference from the PPG before finding the heart beat frequency using the Short Time Fourier Transform (STFT).

3. Results and discussion

3.1. Qualitative comparisons

Figs. 3 and 4 show 70 s example sections of the motion signals recorded during walking and high resistance biking respectively. Readily apparent is the 1 g component due to gravity in the accelerometer output which manifests mainly in one axis (axis 2 in Fig. 3, axis 3 in Fig. 4), with this axis

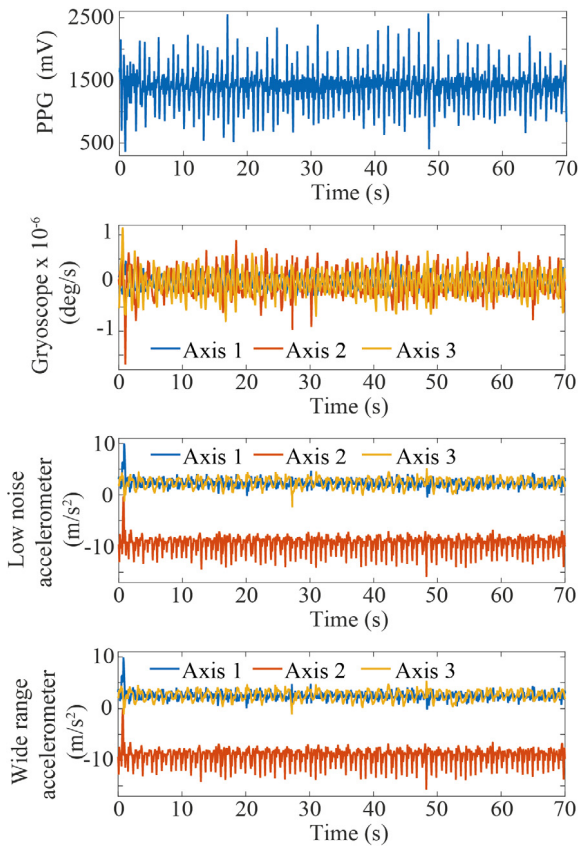

Fig. 3. PPG, gyroscope and accelerometers during walking.

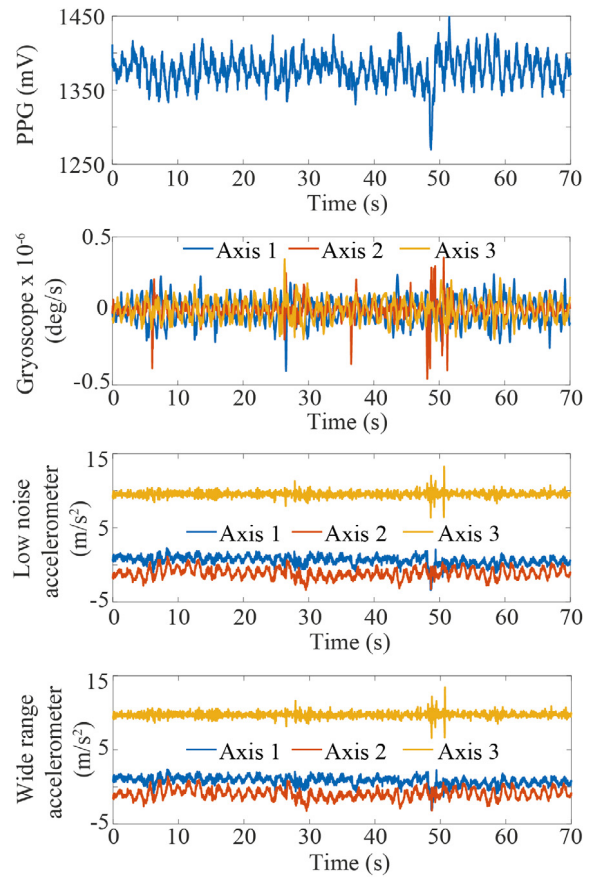

Fig. 4. PPG, gyroscope and accelerometers during biking.

changing as the subject moves from standing during walking to a seated biking position. Such an offset is not seen in the gyroscope data.

The walking data (Fig. 3) is generally free of large transients in the accelerometer output, with this instead being a periodic signal at the footfall frequency. The FFT of the gyroscope and accelerometer data for axis 1 is shown in Fig. 5. This shows that both sensors extract the dominant footfall frequency (1.27 Hz), and a sub-harmonic at the full gait cycle (0.64 Hz). The dominant frequency in the PPG trace is the footfall frequency of 1.27 Hz. Beyond these, the precise estimation of motion is very different from the two types of sensor. In particular the accelerometer reports much more activity at both high and low frequencies, with a peak in the 7–9 Hz range common across many recordings.

In contrast in the biking condition many large amplitude transients are seen, for example at 50 s in Fig. 4, occurring when the subject repositions their hands on the handle bar, and an artifact is seen in the time domain PPG at this point. While both the accelerometer and gyroscope capture that a transient occurs at this time, the precise shapes, Fig. 6, are very different.

3.2. Correlations of motion information

These differences in the motion recordings are quantified in Table 2 which shows the correlations between the gyroscope and low noise accelerometer data. (For compactness the correlations with the wide range accelerometer are not shown.

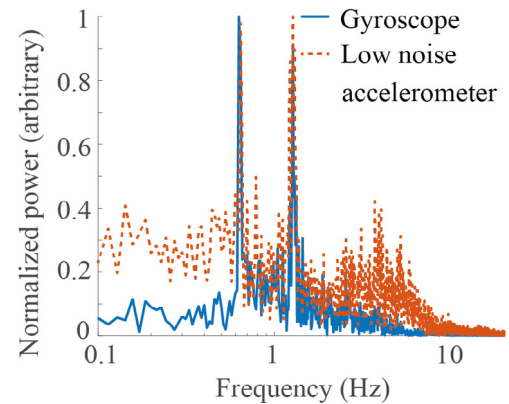

Fig. 5. Normalized FFT power during walking.

These are very highly correlated, >0.95, with the low noise accelerometers.)

In Table 2 all of the correlation coefficients are low, with few greater than 0.5. Although the accelerometers and gyroscopes are sampled simultaneously and are rigidly connected together inside the same package, the resulting signals have very different morphologies, giving different representations of the motion present.

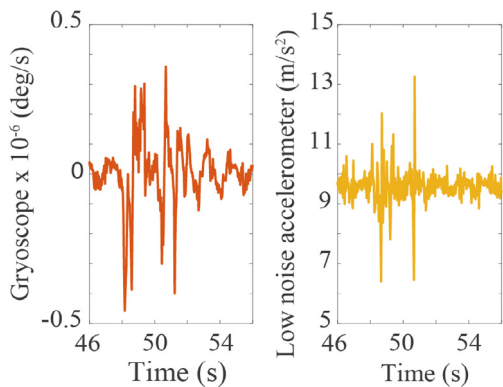

Fig. 6. Biking hand movement artifact from the two sensors.

3.3. Algorithm performance

The heart rate algorithm accuracy is given in Table 3. This shows the mean absolute deviation of the heart rate measured in each record, using the PPG signal and accelerometer/gyroscope input, compared to a gold standard heart rate found from a simultaneous chest ECG measurement. ECG heart rate was derived via the R peak locations, identified using the Pan Tompkins algorithm with incorrect/misplaced R peaks removed by eye.

On our challenging PPG database which contains a range of example motions, and many transient events which are known to cause poor performance [6], the current adaptive filter does not always converge (lines highlighted in gray in Table 3), and further algorithm development is necessary to give usable performances in all cases. Using the accelerometer signals the absolute mean error across all records is 6.9 beats per minute. Using the gyroscope data this increases to 9.9 beats per minute, although this is highly variable. For half of the subjects the error rate is improved by using the gyroscope information in place of the accelerometer, for half of the subjects the error rate is increased. This makes it apparent that useful motion information is being provided by the gyroscopes, but making optimal use of this requires a data fusion stage.

Such fusion techniques are common in activity tracking to find the orientation and rotational velocity of the sensor [8,9] and such a fused estimate of motion could be used to provide a single, better, motion input to the heart rate algorithm. Alternatively it may be possible to dynamically switch between using accelerometer data or gyroscopic data at different points in time. One of the key challenges in using gyroscope information in a wearable is that gyroscopes use much more power than accelerometers and thus a periodic sampling of gyroscope data to augment the motion estimation provided by the accelerometers might be highly desirable.

4. Conclusions

This article has, for the first time, investigated simultaneous gyroscope data for removing motion artifacts from wrist PPG to give improved heart rate estimates during motion compared to using only accelerometer measures as used conventionally. When used in a heart rate extraction algorithm gyroscope mo-

Table 2

Correlation coefficients between accelerometer (A_X) and gyroscope (G_X) data on axis X .

Record	G_1 vs.	G_1 vs.	G_1 vs.	G_2 vs.	G_2 vs.	G_3 vs.
	A_1	A_2	A_3	A_2	A_3	A_3
s1_walk	0.21	-0.20	0.55	-0.03	0.14	-0.46
s1_lrb	0.08	0.01	0.02	0.03	-0.03	0.00
s1_hrb	0.12	0.03	0.08	0.02	-0.04	0.08
s2_walk	0.11	0.00	0.43	0.16	0.25	-0.39
s2_lrb	0.05	0.02	0.04	0.07	-0.04	0.04
s2_hrb	0.03	0.02	0.04	0.01	-0.11	0.07
s3_walk	0.12	-0.20	0.53	0.28	0.10	-0.33
s3_run	0.28	0.02	0.63	0.23	0.15	-0.48
s3_lrb	-0.02	0.04	0.02	-0.01	-0.01	-0.02
s3_hrb	0.01	0.13	0.02	-0.07	-0.02	-0.03
s4_run	-0.26	0.04	-0.12	-0.29	0.05	-0.05
s5_run	0.43	-0.25	-0.37	0.40	-0.41	-0.49
s5_lrb	0.65	-0.51	-0.45	0.47	0.55	-0.49
s6_walk	0.01	0.01	-0.04	0.03	0.00	-0.02
s6_run	0.06	-0.04	0.06	0.09	0.05	-0.12
s6_lrb	0.06	-0.02	0.02	-0.07	0.06	0.03
s8_walk	-0.08	0.15	-0.56	0.03	-0.39	0.53
s8_run	-0.21	-0.06	-0.42	-0.01	-0.18	0.32
s9_walk	-0.03	0.13	-0.55	-0.23	-0.25	0.43

Table 3

Heart rate extraction performance comparison using different measures of motion as the adaptive filter input.

Subject	Error rate (bpm)	
	Accelerometer	Gyroscope
1	12.1	11.4
2	19.9	19.1
3	–	–
4	–	–
5	2.0	10.7
6	5.3	0.1
8	1.2	8.9
9	0.6	9.3
[Mean]	6.9	9.9

tion estimates obtained better performance in half of the cases. The results have characterized the motion recordings obtained from both types of sensor for the first time and demonstrated that both may have a role in further decreasing the error rate in wrist PPG.

Acknowledgment

This work was in part supported by the UK EPSRC Research Council grant number EP/M009262/1.

Conflict of interest

The authors declare that there is no conflict of interest in this paper.

References

- [1] R. Benson, D. Connolly, Heart Rate Training, Human Kinetics, Champaign, 2011.
- [2] A. Carpenter, A. Frontera, Smart-watches: a potential challenger to the implantable loop recorder? *Europace* (4) (2016) 1–3.
- [3] A. Honka, K. Kaipainen, H. Hietala, et al., Rethinking health: ICT-enabled services to empower people to manage their health, *IEEE Rev. Biomed. Eng.* 4 (1) (2011) 119–139.

- [4] R. Krishnan, B. Natarajan, S. Warren, Two-stage approach for detection and reduction of motion artifacts in photoplethysmographic data, *IEEE Trans. Biomed. Eng.* 57 (8) (2010) 1867–1876.
- [5] S.E. Stahl, H.-S. An, D.M. Dinkel, et al., How accurate are the wrist-based heart rate monitors during walking and running activities? Are they accurate enough? *BMJ Open Sport Exerc. Med.* 2 (1) (2016) 119–139.
- [6] E. Khan, F.A. Hossain, S.Z. Uddin, et al., A robust heart rate monitoring scheme using photoplethysmographic signals corrupted by intense motion artifacts, *IEEE Trans. Biomed. Eng.* 63 (3) (2016) 550–562.
- [7] Z. Zhang, Z. Pi, B. Liu, TROIKA: A general framework for heart rate monitoring using wrist-type photoplethysmographic signals during intensive physical exercise, *IEEE Trans. Biomed. Eng.* 62 (2) (2015) 522–531.
- [8] K. Tong, M.H. Granat, A practical gait analysis system using gyroscopes, *Med. Eng. Phys.* 21 (2) (1999) 87–94.
- [9] R.E. Mayagoitia, A.V. Nene, P.H. Veltink, Accelerometer and rate gyroscope measurement of kinematics: an inexpensive alternative to optical motion analysis systems, *J. Biomech.* 35 (4) (2002) 537–542.
- [10] Shimmer. [Internet]. Available: www.shimmersensing.com.
- [11] Scosche. [Internet]. Available: www.scosche.com/rhythm+.
- [12] D. Jarchi, A.J. Casson, Estimation of heart rate from foot worn photoplethysmography sensors during fast bike exercise, in: *IEEE EMBC*, Orlando, 2016.
- [13] T. Schack, C. Sledz, M. Muma, et al. A new method for heart rate monitoring during physical exercise using photoplethysmographic signals, in: *EUSIPCO*, Nice, 2015.