



Kent Academic Repository

Batchelor, John C., Economou, L. and Langley, Richard J. (2000) *Scanned microstrip arrays using simple integrated ferrite phase shifters*. IEE Proceedings - Microwaves Antennas and Propagation, 147 (3). pp. 237-241. ISSN 1350-2417.

Downloaded from

<https://kar.kent.ac.uk/16089/> The University of Kent's Academic Repository KAR

The version of record is available from

<https://doi.org/10.1049/ip-map:20000428>

This document version

Author's Accepted Manuscript

DOI for this version

Licence for this version

UNSPECIFIED

Additional information

Versions of research works

Versions of Record

If this version is the version of record, it is the same as the published version available on the publisher's web site. Cite as the published version.

Author Accepted Manuscripts

If this document is identified as the Author Accepted Manuscript it is the version after peer review but before type setting, copy editing or publisher branding. Cite as Surname, Initial. (Year) 'Title of article'. To be published in *Title of Journal*, Volume and issue numbers [peer-reviewed accepted version]. Available at: DOI or URL (Accessed: date).

Enquiries

If you have questions about this document contact ResearchSupport@kent.ac.uk. Please include the URL of the record in KAR. If you believe that your, or a third party's rights have been compromised through this document please see our [Take Down policy](https://www.kent.ac.uk/guides/kar-the-kent-academic-repository#policies) (available from <https://www.kent.ac.uk/guides/kar-the-kent-academic-repository#policies>).

**Scanned microstrip arrays using simple integrated ferrite
phase shifters**

J.C. Batchelor, L. Economou and R.J. Langley

This paper is a postprint of a paper submitted to and accepted for publication in IET Microwaves, Antennas and Propagation and is subject to Institution of Engineering and Technology Copyright. The copy of record is available at IET Digital Library

Scanned microstrip arrays using simple integrated ferrite phase shifters

J.C. Batchelor, L. Economou and R.J. Langley

**Department of Electronics, The University of Kent, Canterbury, Kent, CT2 7NT,
UK.**

Email: J.C.Batchelor@ukc.ac.uk

ABSTRACT

A phase-steered microstrip antenna array is presented, suitable for application as a mobile vehicle satellite terminal. Phase shifters are implemented on a hybrid dielectric-ferrite substrate, and use is made of the phase transition near the cut-off region of the biased ferrite. Small permanent magnets and carefully biased ferrites remove the need for large applied electromagnetic fields. 2-, 3- and 4-element demonstrator arrays have been constructed, and up to 30° beam squint has been achieved. For applied magnetic biases of about 1000e.

INTRODUCTION

The introduction of a new generation of communication systems involving a mobile terminal-to-satellite link, such as Iridium, Globalstar, Odyssey and ICO-Global [1, 2], and vehicular anti-collision radar systems, means that compact inexpensive antennas with beam-steering capability will become desirable. However, conventional phase-driven arrays are expensive, complex and unsuited to integration in hand-held or vehicle-mounted terminals. The aim of this paper is to describe the design and performance of an uncomplicated beam-steered printed array with integrated ferrite phase shifters [3].

The permeability of a ferrite with an applied static or low-frequency magnetic field changes according to the applied field strength [4]. Interesting properties, such as frequency tuning and reduction in RCS, have been reported. The variable

permeability has been used here to change the electrical length of microstrip lines traversing the ferrite substrate. Usually significant changes in bias field strength are necessary to bring useful phase changes along the line [5, 6], and large electromagnetic currents are required. We have made use of the ferrite behaviour near the cut-off region where microstrip modes do not propagate. With an increasing applied magnetic field, there is a rapid phase change associated with the ferrite permeability as the cut-off region is approached. It is this region of fast phase change that produces a large phase shift for a small alteration in the applied field.

The resonant frequency of radiating elements printed on ferrite substrates alters with applied bias [7]. This unwanted effect is eliminated by utilising a substrate composed of both ferrite and dielectric regions. The radiating patches and phase shifters are printed on the dielectric and ferrite substrates, respectively. Results are presented for arrays of two and three elements, and two different phase-shifter line layouts are tested. A useful amount of beam steering (30°) is predicted and measured.

The insertion loss of phase-shifting elements is an important parameter, as it can negate array gain improvement. Measurements have been taken to ensure that absorption in the ferrite substrate does not significantly reduce the array gain.

2 Microwave ferrites

When ferrites are biased by a static magnetic field, the permeability of the medium is given by the well known Polder tensor. For a bias field directed normally to the surface of a ferrite slab, the effective permeability of the medium can be derived from the tensor [8]:

$$\mu_{eff} = \frac{\mu^2 - \kappa^2}{\mu} \quad (1)$$

The tensor elements μ and κ are given by

$$\mu = 1 + \chi'_{xx} - j\chi''_{xx} \quad \text{and} \quad \kappa = \chi'_{xy} - j\chi''_{xy} \quad (2)$$

The complex magnetic susceptibilities are given by Pozar [8].

Fig. 1 shows the complex permeability of a ferrite above saturation at 7.8GHz. The material parameters of the ferrite are given in Table 1. Two resonances are visible. Signal attenuation is associated with the imaginary part of μ_{eff} and the resonance peaks correspond to regions of maximum absorption. Note that the position of these peaks is frequency-dependent.

Table 1: Parameters of G-350 YIG ferrite

ϵ_r	μ_r (unbiased)	h	Saturation field	ΔH
13.69	1	1mm	350Oe	30Oe

Peak A is the absorption resonance where the tensor component $p = 0$. This causes the effective ferrite permeability to become indeterminate, and propagating waves in the medium are strongly attenuated. The region of interest for this application occurs just before the absorption resonance (peak A). Peak B corresponds to the gyromagnetic resonance where RF power couples maximally to the precessing magnetons in the crystal lattice. As the magnetic bias field is increased from saturation towards absorption resonance, another region of interest is encountered. This is the cut-off region where $\mu_{\text{eff}} < 0$, and consequently wave propagation is prevented within the ferrite. The value of the real part of μ_{eff} decreases rapidly as the cut-off point is approached, and this alters the electrical length of a microstrip line printed on the ferrite.

To test this theory, a 5cm long microstrip line phase shifter (as shown in Fig. 2) was produced, where 2cm of the line was affected by the biasing magnetic field. Fig. 3 shows the measured S_{12} , parameter of the line. It can be seen that there is a significant phase shift occurring before the cut-off point is encountered, with a change of over 20° achieved in the region between 2.3 and 2.4KOe. The attenuation at field strengths above 2.4KOe is due to the cut-off region. This region of rapid phase change, with little increase in attenuation at magnetic bias levels just below cut-off, is used in this work to realise printed ferrite phase shifters integrated with microstrip antenna arrays.

3 Array design

An array incorporating a travelling wave feed is most suitable for this application, as it allows a progressive phase shift to be included with equal increments between radiating elements. A corporate feed, although somewhat easier to design, requires differing phase delays at branched points to produce a linear phase slope at the array elements. This translates to magnetic bias fields of different strengths, varying in proportion to each other.

The 2- and 3-element ray results presented in this paper are taken from a linear array of circular patches excited by a series feed. Fig. 4 shows the geometry of the 3 element array, indicating the structure of the ferrite-dielectric substrate. The substrate dimensions are 110mm x 70mm. Mobile-to-satellite systems often require circularly polarised antennas. These can be produced in the discussed arrays by introducing notch perturbations to the patches, with no modification required to the feed structure [9]. All the presented arrays are linearly polarised.

A 3-element array was designed on 5870 RT duroid with a binomial feed amplitude distribution. Phase shifters were created by routing two sections of line between the antenna elements over a region of ferrite in the substrate plane. Circular printed patches operating in the TM₀₁ mode were selected as the radiating elements. This mode has a single beam directed to the zenith and a half-power beam width of 60°. The design parameters are given in Table 2.

Table 2: Parameters of microstrip patch on 5870 RT-duroid

ϵ_r	Substrate thickness, h	Frequency	Patch radius
2.33	0.787mm	7.8GHz	7.0mm

The regions of microstrip traversing the ferrite substrate were designed to be of similar length and characteristic impedance to each other, to ensure that the application of identical magnetic bias at each point would produce a uniform phase gradient. The unbiased phase lengths were chosen to give an initial zero phase difference between adjacent array elements. Potential mismatches at the substrate transition could be minimised by selecting a dielectric with permittivity similar to that of the ferrite. However, the extremely thin high impedance lines that this would produce make feed-matching a serious problem. Low permittivity substrates improve

printed antenna efficiency and bandwidth. It was determined experimentally that using a low dielectric substrate below the patches did not cause a significant discontinuity at the ferrite transition, provided that the line width is adjusted accordingly to minimise the impedance mismatch. Little radiation loss was detected. The feed design frequency was made insensitive to applied bias field, by ensuring that no highly frequency dependent components (e.g. impedance transformers) were placed on the ferrite.

4 Simulation

The array was designed and simulated using the Hewlett Packard software package Momentum, which is based on the method of moments technique. It was necessary to model the two sections of the hybrid substrate separately, due to the planar nature of the modelling process. The starting point for the design and simulation was zero magnetic bias, with the parameters given in Table 1. The phase shifts under bias were predicted using eqns. 1 and 2 with simple array theory for radiation pattern calculation.

In addition, note that Momentum does not model surface waves in the substrate, a common cause of coupling between arrayed microstrip patches. However, as the substrate permittivity was low and the height small, surface waves were not expected to contribute to significant mutual coupling between radiating elements.

5 Results

The performance of the phase shifters was assessed by S-parameter measurement on a Wiltron 360 network analyser. The phase shifters were jig-mounted so that the ferrite-dielectric transition was included in the measurement.

Fig. 5 shows S_{12} for two designs of phase shifter. Design 1 was a simple 3 length U shape, and design 2 was convoluted to increase the line length affected by the bias field. The measured insertion loss of designs 1 and 2 remained below 0.5dB and 1dB, respectively. In the region well below cut-off, and assuming the phase change with applied field is linear, design 1 exhibited a phase gradient of $65^\circ/\text{KOe}$ and design 2 had a slope of $112^\circ/\text{KOe}$. Detailed measurement of phase change immediately around the cut-off point for design 2 yielded a phase shift of $90^\circ/100 \text{ Oe}$ for a 2dB increase in

transmission loss. This shows an 8-fold increase in the phase / field slope compared to the region well below cut-off.

The measured figures-of merit (FOM) for designs 1 and 2 were $30^\circ/\text{dB}$ and $150^\circ/\text{dB}$, respectively, where FOM is defined as the phase change over which a 1dB loss increment is experienced.

An insertion loss of 2.19dB was measured for design 2 with zero bias where no magnetic absorption will occur. The insertion loss increased by only 0.3dB in the biased region just below cut-off. This suggests that the ferrite is not intrinsically causing the above poor S_{12} magnitudes. The ferrite manufacture's quoted dielectric loss tangent is ≤ 0.0002 , which compares well with good quality microwave dielectric materials. A probable cause of the poor transmission loss is the low quality of the metallisation on the ferrite. It was not possible to obtain metal-clad ferrite samples: all phase shifters were constructed by affixing copper foil to the substrate surface with aerosol adhesive.

Insertion losses as low as 1.2dB were measured for some trial designs in the bias region close to cut-off. Meanderline phase shifters with closely coupled elements on ferrite have been studied previously [10]. This work indicates that using multilayer structures and stepped admittances at the edge sections of the meanderline may improve the phase shifter performance. The input sections are necessary to match the even and odd mode phase behaviour caused by coupling. The convoluted lines presented in this work are not as tightly coupled as those of Hansson *et al.* [10], and multi section input matching is thought to be less important. However, this will be studied in an attempt to optimise the phase shifter performance.

Fig. 6 shows the radiation patterns, both experimental and theoretical, of a magnetically steered 2-element array. Measurements show that a significant change in beam direction occurs, up to 25° for a change of only 120 Oe in the applied DC magnetic field. In general, the more elements an array has, the further a given phase progression will steer the beam. The side-lobes increase as expected for a 2-element uniformly excited array. There is reasonable agreement with theory.

A 3-element array was built and tested. The array gain was measured to be 4.3dB below that of an identical array with no ferrite present. The cause of this discrepancy

is the insertion loss of the two ferrite phase shifters (reasons for this are presented above). This was 2.19dB per phase shifter, giving close agreement with the recorded gains. S_{11} was measured to be -20dB at 7.8GHz. The operating frequency of the array is independent of applied bias. Fig. 7 shows the measured array patterns, together with those calculated by array theory. There is an 8° squint at zero bias, which is due to a small phase length error in the phase shifters. The differences in elevation angle between theory and measurement are caused by ground plane effects, and disturbance to the binomial amplitude distribution caused by differences between the two phase shifters that degrade the array factor and reduce the anticipated steering effect. The side-lobe levels remain \sim -7.5dB below the main beam for the entire steering process. Fig. 7 shows the main beam elevation angle steers up to 30° with magnetic field before the ferrite enters the cut-off region.

Design expressions for microstrip on ferrite substrates developed by Pucel and Masse [11] were used to calculate the phase change expected for the phase shifters. The results were compared with the uniform phase progression required to steer the array beam to the measured angles. Fig. 8 shows that the agreement with measurement is good. The maximum phase error is 12° , which corresponds to a pointing error of 2° . The input match between the biased line and a reference $50\ \Omega$ line was calculated, to assess the phase shifter bandwidth. The bandwidth between the operating point at 7.8GHz and the -10 dB S_{11} frequency was just over 5%, which exceeds the usual bandwidth of the microstrip patches.

A 4-element array with a corporate feed was also produced. Although the symmetrical branching feed was somewhat simpler to design than the series case, biasing was more complicated as different field strengths were required at different points. The side-lobe levels were also high as all four elements were excited uniformly in magnitude. Beam steering of 35° was achieved for bias strengths comparable with the 3-element series feed array, but the radiation patterns were of a poor quality due to the bias field interaction between the different phase shift elements. The frequency of operation for the 4-element array was 9GHz.

As with any phased array, beam steering beyond a certain angle will cause the side lobe magnitude to become comparable to that of the main beam. Scan losses and

blindness angles will also be encountered. The limiting factor with these ferrite shifted arrays is an impedance mismatch due to the ferrite cut-off region. Inspection of the main beam attenuation and scan angle with magnetic bias for the 2-element array revealed that attenuation remained low (better than 0.5dB) until cut-off was encountered at 2.3K Oe.

Applying the magnetic bias field normally to the ferrite produces non-reciprocal phase shifting. The scan angle is therefore independent of bias field polarity. Beam steering either side of the zenith can be achieved by designing the array to incorporate a compensating unbiased squint.

The results presented were all obtained by placing permanent magnets at different spacings behind the ferrite substrate. An electromagnet would be necessary for a practical application. This would present a continuous phase shift with applied current, offering a resolution advantage over discrete phase step systems. The steep phase gradient near cut-off could be useful in a practical design to give significant beam shifting with a realistic electromagnet driving current. A static bias field of around 2.1K Oe could be provided by permanent magnets or preferably a pre-biased hexaferrite substrate. We plan to examine hexaferrites for this application.

6 Conclusion

We have presented the concept of a simple and cheap beam-steered array suitable for numerous applications. The array structure is printed on an integrated dielectric-ferrite substrate, where a normally directed magnetic bias is applied to alter the electrical length of a microstrip line on the ferrite. Results have been presented for a 2-element and a binomially fed 3-element array. Each array comprised circular radiating patches operating at the TM_{11} mode. A study was carried out to improve the total phase shift available from one region of microstrip line on the ferrite, and this has resulted in a total phase change of 90° for a bias level change of just 100 Oe. It can therefore be determined that the sharp change in transmission phase immediately before a ferrite enters its cut-off region can successfully be employed to produce a useful phase shift. The insertion loss of the unbiased phase shift elements was derived from the measured S_{11} and S_{12} parameters and was found to be 2.2dB. This was due to plating problems on the ferrites and will be eliminated in future designs. The insertion loss was observed to increase by only 0.3dB as bias increased up to the cut-off point.

For a 2-element array, the applied magnetic bias produced a 30° change in beam elevation without a significant degradation of radiation patterns and the operating frequency remained constant, as all radiating and transforming components were printed on conventional dielectric material. Such an array would be of use where space for antennas was limited, such as on a vehicle. The large bias fields necessary could be provided statically by small permanent magnets or pre-biased hexaferrites, and a small low-current electromagnet varying this field would actuate the beam steering. This is the direction of the next phase of our project. Large phase shifts can be achieved with small variation in bias if the design operates on the very steep phase gradient close to cut-off. The 3-element array gave similar results, but more work is required to balance the performance of the phase shifters. A small difference in applied bias field brings about a large differential in phase between the phase shifters, due to the sensitivity of the process.

The radiation pattern quality and gain could be improved by developing a model of the ferrite-duroid transition to optimise the design. Work to reduce the insertion loss of the ferrite substrate is continuing.

7 References

- 1 EVANS, J.V.: 'Satellite systems for personal communications', *IEEE Antennas Propag. Mag.*, 1997, **39**, (3), pp.7-20
- 2 Godara, L.C. 'Applications of antenna arrays to mobile communications, Part 1: performance improvement, feasibility, and system considerations', *IEEE Proc.*, 1997, **85**, (7), pp. 1031-1060
- 3 Batchelor, J.C., and Langley, R.J.: 'Beam scanning using microstrip line on biased ferrite', *Electron Lett.*, 1997, **33**, (8), pp. 645-646
- 4 Pozar, D.M.: 'Radiation and scattering characteristics of microstrip antennas on normally biased ferrite substrates', *IEEE Trans. Antennas Propag.*, 1992, **40**, (9), pp. 1084-1092
- 5 Bolioli, S., Benzina, H., Baudrand, H., and Chan, B.: 'Centimeter-wave microstrip phase shifter on a ferrite-dielectric substrate', *IEEE Micro. Theory Tech.*, 1989, **37**, (4), pp. 698-705
- 6 Dionne, G.F., Oates, D.E., Temme, D.H., and Weiss, J.A.: '@Ferrite-superconductor devices for advanced microwave applications', *IEEE Trans. Microw. Theory Tech.* 1996, **44**, (7), pp. 1361-1368
- 7 Tsang, K.K., and Langley, R.J.: 'Design of circular patch antennas on ferrite substrates', *IEE Proc. Microw. Antennas Propag.* 1998, **145**, (1), pp. 49-55
- 8 Pozar, D.M.: 'Microwave engineering', (Addison-Wesley, 1990)
- 9 Haneishi, M., Nambara, T., and Yoshida, S.: 'Study on elliptical properties of single-feed type circularly polarised microstrip antennas', *Electron. Lett.*, 1982, **18**, pp. 191-193

10 Hansson, E.R.B, Aditya, S., and Larsson, M.A.: 'Planar meanderline ferrite-dielectric phase shifter', IEEE Trans. Microw. Theory Tech., 1981, **29**, (3), pp. 209-215

11 Pucel, R.A., and Masse, D.J.: 'Microstrip propagation on magnetic substrates – Part 1: design theory', IEEE Trans. Microw. Theory Tech. 1972, **20**, (5), pp. 304-308

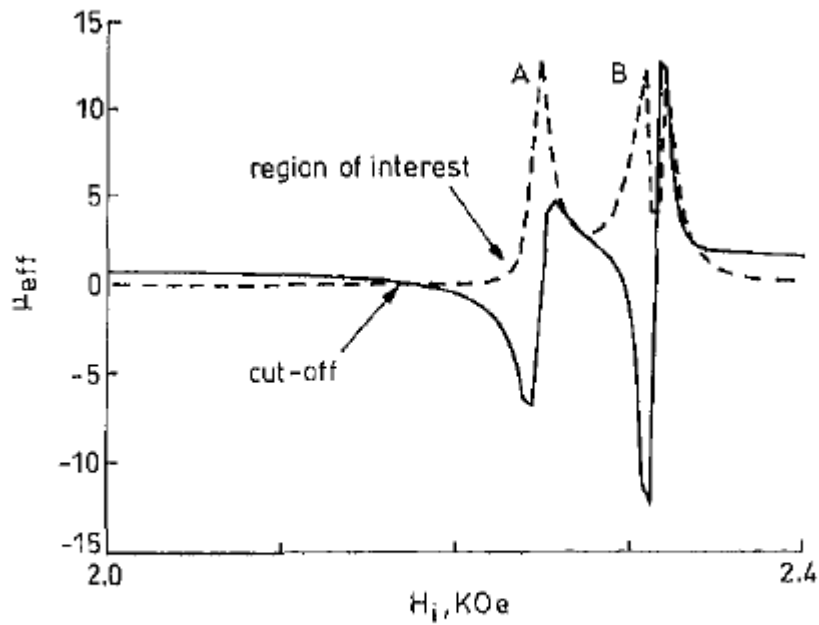

Fig.1 Complex effective permeability against internal bias field for G-350 YIG at 7.8GHz
— real part
- - - imaginary part

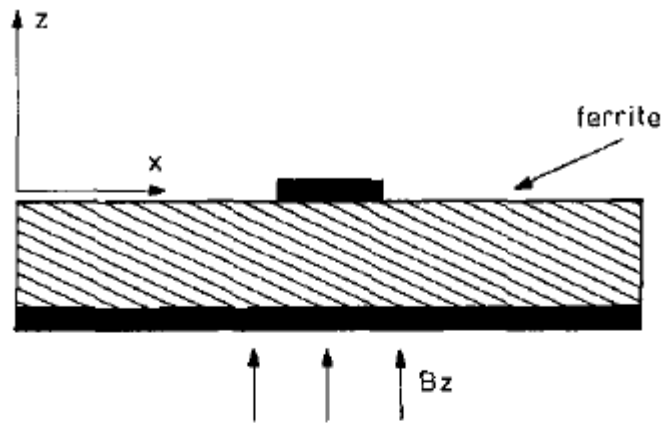

Fig.2 Cross-section of microstrip on ferrite substrate
Bias field applied normal to ground plane

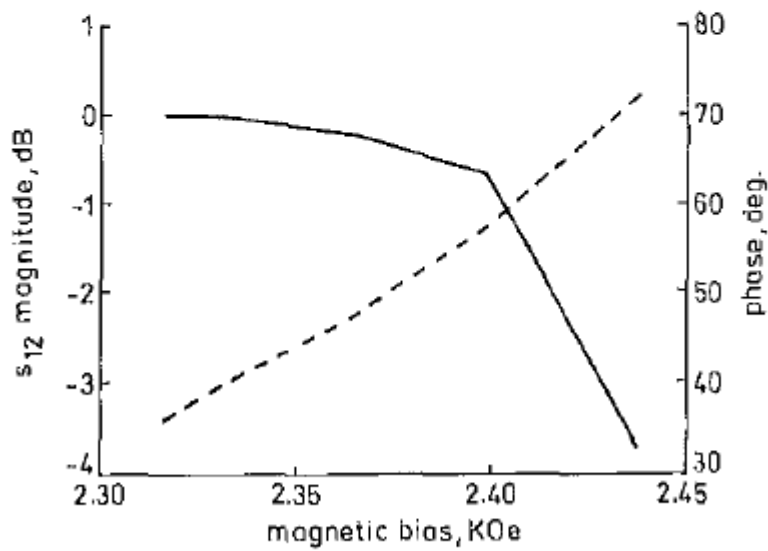

Fig.3 Measured transmission parameter of microstrip on biased ferrite
Vicinity of cut-off point is shown
— magnitude
- - - - phase

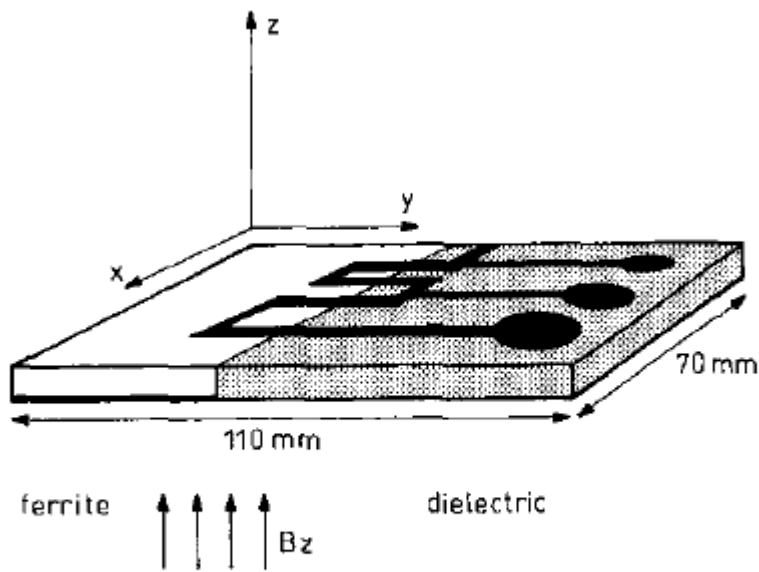

Fig.4 Microstrip array on composite ferrite-dielectric substrate showing phase shifters traversing the ferrite region
Ground plane is stepped to allow for different substrate heights; ground plane measures 110 mm x 70 mm

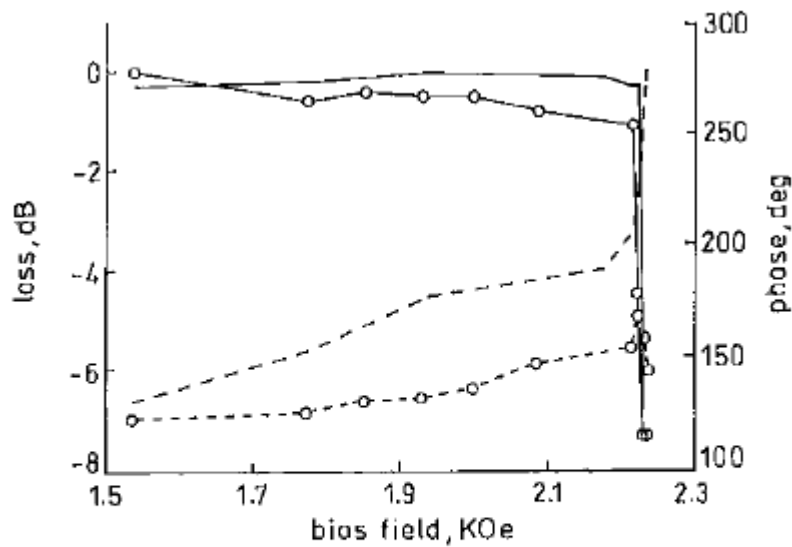

Fig.5 Measured transmission parameters of two phase shifter designs
Design 1
○ - ○ loss
○ - ○ phase
Design 2
- - - loss
- - - phase

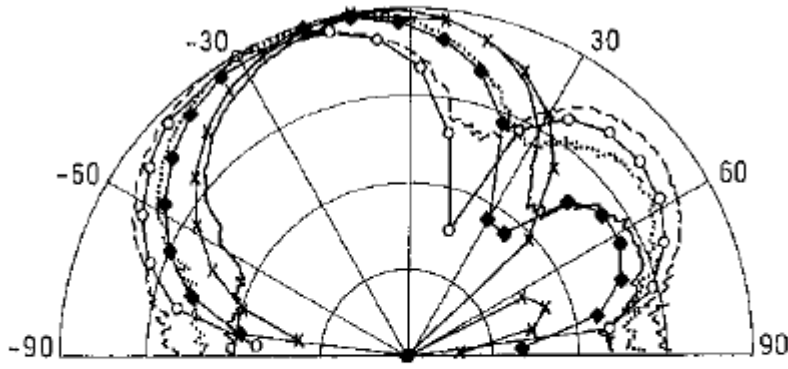

Fig. 6 *Squinted beam with applied bias for 2-element array*

- 1.82 KOe: measured
- ×- × 1.82 KOe: prediction
- 1.92 KOe: measured
- ◆- ◆ 1.92 KOe: prediction
- ... 1.94 KOe: measured
- ○ 1.94 KOe: prediction

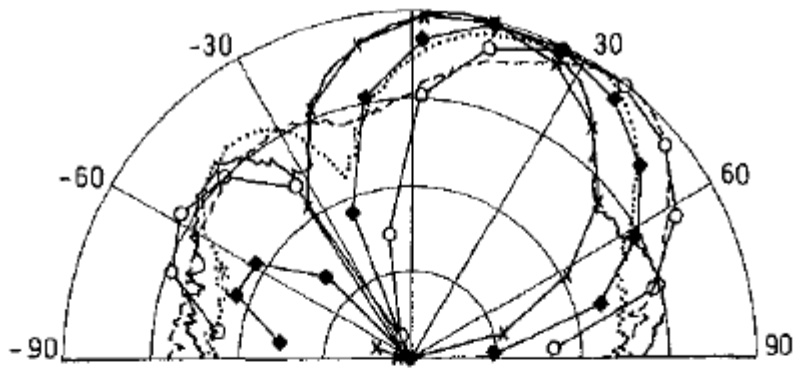

Fig.7 Squinted beam with applied bias for 3-element array

- 0.0 KOe: measured
- ×—× 0.0 KOe: prediction
- 1.42 KOe: measured
- ◆—◆ 1.42 KOe: prediction
- 1.96 KOe: measured
- 1.96 KOe: prediction

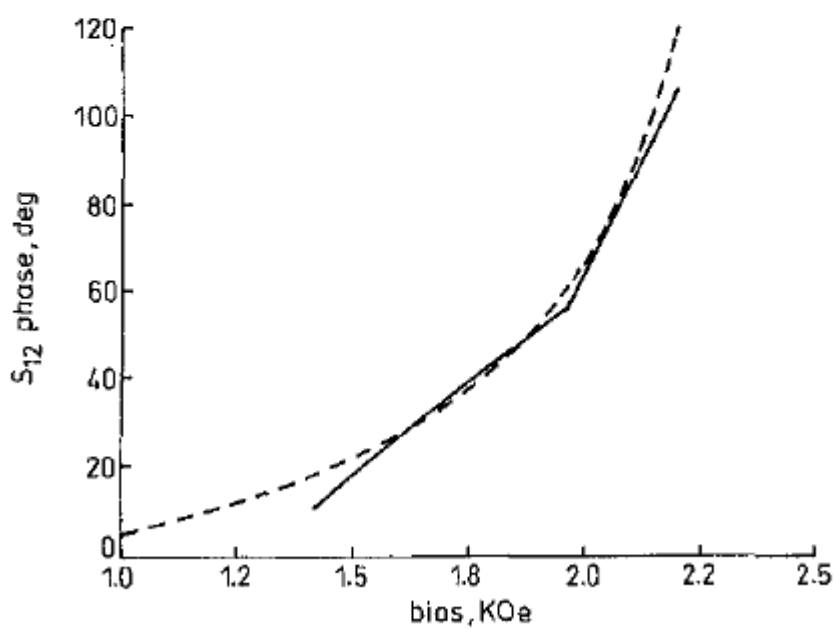

Fig.8 Comparison of measured and predicted microstrip phase shift with applied bias

- measured
- predicted