

# Kent Academic Repository

## Full text document (pdf)

### Citation for published version

Gomes, Nathan J. and Assimakopoulos, Philippos and Elbers, Jorg-Peter and Munch, Daniel and Chanclou, Philippe and Jungnickel, Volker (2017) Concepts and requirements for the Ethernet-based evolved fronthaul. In: 2017 IEEE Photonics Society Summer Topical Meeting Series (SUM). IEEE pp. 41-42. ISBN 9781509065707.

### DOI

<https://doi.org/10.1109/PHOSST.2017.8012641>

### Link to record in KAR

<http://kar.kent.ac.uk/64163/>

### Document Version

Author's Accepted Manuscript

#### Copyright & reuse

Content in the Kent Academic Repository is made available for research purposes. Unless otherwise stated all content is protected by copyright and in the absence of an open licence (eg Creative Commons), permissions for further reuse of content should be sought from the publisher, author or other copyright holder.

#### Versions of research

The version in the Kent Academic Repository may differ from the final published version.

Users are advised to check <http://kar.kent.ac.uk> for the status of the paper. **Users should always cite the published version of record.**

#### Enquiries

For any further enquiries regarding the licence status of this document, please contact:

[researchsupport@kent.ac.uk](mailto:researchsupport@kent.ac.uk)

If you believe this document infringes copyright then please contact the KAR admin team with the take-down information provided at <http://kar.kent.ac.uk/contact.html>

# Concepts and Requirements for the Ethernet-based Evolved Fronthaul

Nathan J. Gomes, Philippos Assimakopoulos  
Communications Research Group  
University of Kent  
Canterbury, UK

Philippe Chanclou  
Fixed Networks Research Unit  
Orange Labs  
Lannion, France

Jörg-Peter Elbers, Daniel Münch  
CTO Office, Advanced Technology  
ADVA Optical Networking  
Munich, Germany

Volker Jungnickel  
Metro-, access and in-house systems group  
Fraunhofer-HHI  
Berlin, Germany

**Abstract**—The use of Ethernet in the fronthaul permits convergence and exploitation of statistical multiplexing gains of the new interfaces, but minimum latency and latency variation requirements may become challenging. The techniques proposed to meet these challenges are summarized.

**Keywords**—*Mobile fronthaul, optical access networks, Ethernet*

## I. INTRODUCTION

The drive for ever-increasing data rates for mobile users requires shorter wireless distances, such as through the use of small cells, the use of the wider spectrum available at millimeter-wave frequencies and enhanced intercell cooperation and coordination. Centralized- or Cloud-radio Access Networks (C-RANs) are seen an important in delivering this vision [1]. However, up to now the technology used for the fronthaul connecting base station baseband unit pools to remote radio heads has been predominantly based on the transport of sampled radio waveforms, using industry standards such as the Common Public Radio Interface (CPRI). Recent works have clearly indicated that CPRI-type transport will lead to infeasible bit-rates for wide radio bandwidths, and especially if multi-antenna techniques to improve radio spectrum efficiency are employed [2].

Further efficiency gains for the fronthaul network can be obtained by transporting user data instead of waveform samples and making use of statistical multiplexing [3]. Such packet-mode transport would also allow convergence with fixed access networks, potentially reducing costs through economies of scale and use of common, standardised network technologies. The use of Ethernet is a prime candidate [3]. In this paper, we examine the fronthaul interface options that can enable more efficient transport network profiles than CPRI, and their requirements. We then discuss how Ethernet can be used in this new, evolved fronthaul. Finally, we provide an overview of technology requirements that will enable the aggregation of different traffic types at high rates that will be necessary.

## II. EVOLVED FRONTHAUL INTERFACE

Many industry bodies and projects are now studying new or next generation fronthaul interface options for the RAN [4], [5]. Fig. 1 shows some interfaces or split points in relation to LTE-type network RAN functions, with options currently being discussed within 3GPP shown [5]. A typical base station is connected at split point 1. Split point 8 is the current CPRI split, while the points between represent new possibilities. In 3GPP terminology, there are now central units which can be increasingly virtualised (vCUs) instead of BBU pools, and distributed units (DUs), generally consisting of more than the radio functions of RRHs. In general, moving the split point to the left relaxes latency requirements and reduces bit-rates, but possibilities such as joint processing of the wireless signals are lost. There is also a more general classification between higher-layer, non-real-time splits and lower-layer real-time splits. For the lower-layer splits, both latency and latency variation (e.g. packet jitter) are important. Finally, there is also a need for absolute time alignment, especially for coordinated transmission and reception schemes, requiring time reference signals to be transported.

## III. ETHERNET IN THE EVOLVED FRONTHAUL

The evolved fronthaul may consist of a range of different split points, to enable co-existence with legacy fronthaul and backhaul, as shown in Fig.2, and with fixed access networks, and to enable service-dependent operation [3]. Ethernet provides the ability to mix different traffic types with statistical multiplexing gains possible. It also provides standardised control and management functions, and timing through Synchronous Ethernet and Precision Timing Protocol (PTP – IEEE 1588). However, the packet mode transport does not inherently provide the synchronous operation inherent in CPRI, and any introduction of statistical multiplexing means that delay variability through contention is inevitable [3]. It is essential in such cases that appropriate transport profiles are defined for the relevant fronthaul interfaces; these must distinguish between

traffic types, attempting to give minimum latency and jitter to timing signals and control primitives, for example, without which complete radio frames might be lost. Schemes for doing this, based on prioritizing and using techniques such as filling inter-packet gaps, pre-emption and time-aware scheduling, have been discussed within the IEEE P802.1CM Time-Sensitive Networks for Fronthaul group [6].

#### IV. HIGH DATA-RATE FRONTHAUL

New functional splits are essential in making fronthaul bit-rates feasible for forthcoming mobile networks, but once aggregated, very high bit-rates in the access network will still be necessary. Low-cost, high bit-rate techniques, building on developments for data centre networks provide a direction for future research [7]. Additionally, overlaying on fixed access networks can be done through the use of point-to-point (PtP) WDM over a PON, as shown in Fig.3.

#### V. CONCLUSIONS

New Ethernet transport profiles for the fronthaul based on new RAN functional splits enable feasible bit-rates and

prioritization of different traffic types. Time-sensitive networking techniques have been proposed to meet the requirements of the most demanding latency and jitter-sensitive fronthaul traffic. High aggregate bit-rates must still be delivered at low-cost and convergent with fixed-access.

#### REFERENCES

- [1] China Mobile Research Institute, White Paper, C-RAN: The road towards green RAN, 2011
- [2] U. Dötsch et al, "Quantitative analysis of split base station processing and determination of advantageous architectures for LTE", Bell Labs Tech vol. 18, pp. 105-128, 2013.
- [3] N.J. Gomes, et al . "A flexible, Ethernet fronthaul for 5<sup>th</sup> generation mobile and beyond", OFC 2016, Anaheim, CA, 2016
- [4] IEEE 1914 Next Generation Fronthaul Interface Working Group, <http://sites.ieee.org/sagroups-1914/>
- [5] 3GPP, "3GPP TR 38.801 v1.0.0 Rel-14 Study on New Radio Access Technologies: Radio Access Architecture and Interfaces", 2016
- [6] IEEE, "IEEE P802.1CM Draft 0.5 Time-Sensitive Networks for Fronthaul", 2016, <http://www.ieee802.org/1/pages/802.1cm.html>
- [7] C. Kottke et al, "178 Gb/s short-range optical transmission based on OFDM, electrical upconversion and signal combining", ECOC 2016, Dusseldorf, 2016

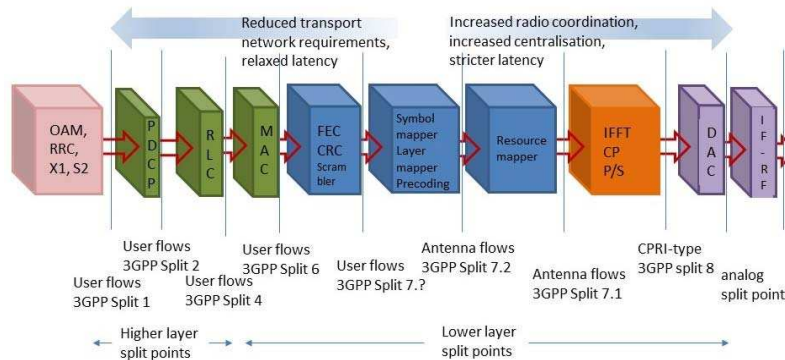

Fig. 1 RAN interface split points

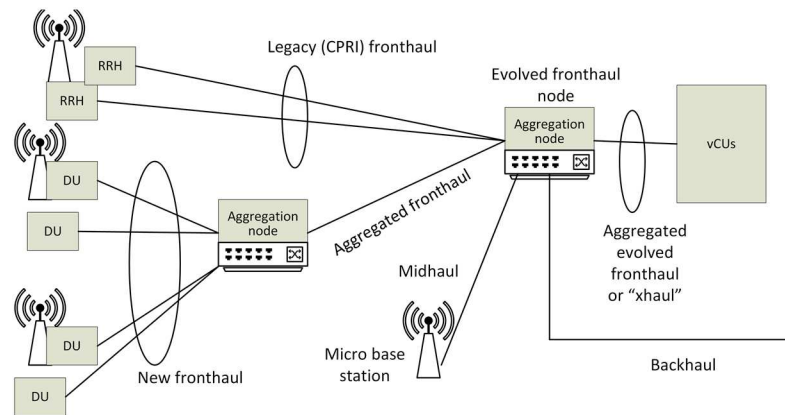

Fig. 2 Evolved Ethernet fronthaul/"xhaul"

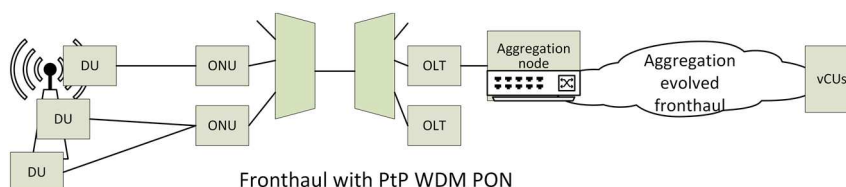

Fig.3 Overlaying the fronthaul on a PON using point-to-point WDM