

Kent Academic Repository

Full text document (pdf)

Citation for published version

Wikner, J. and Naim, M.M. and Spiegler, V.L.M. and Lin, J. (2017) IOBPCS based models and decoupling thinking. International Journal of Production Economics, 194 . pp. 153-166. ISSN 0925-5273.

DOI

<https://doi.org/10.1016/j.ijpe.2017.05.009>

Link to record in KAR

<http://kar.kent.ac.uk/61712/>

Document Version

Author's Accepted Manuscript

Copyright & reuse

Content in the Kent Academic Repository is made available for research purposes. Unless otherwise stated all content is protected by copyright and in the absence of an open licence (eg Creative Commons), permissions for further reuse of content should be sought from the publisher, author or other copyright holder.

Versions of research

The version in the Kent Academic Repository may differ from the final published version.

Users are advised to check <http://kar.kent.ac.uk> for the status of the paper. **Users should always cite the published version of record.**

Enquiries

For any further enquiries regarding the licence status of this document, please contact:

researchsupport@kent.ac.uk

If you believe this document infringes copyright then please contact the KAR admin team with the take-down information provided at <http://kar.kent.ac.uk/contact.html>

IOBPCS Based Models and Decoupling Thinking

Joakim Wikner¹, Mohamed M. Naim², Virginia L. M. Spiegler³ and Junyi Lin⁴

¹ Department of Management and Engineering, Linköping University, Linköping, Sweden
joakim.wikner@liu.se

² Logistics Systems Dynamics Group, Cardiff Business School, Cardiff University, Cardiff, UK
naimmm@cardiff.ac.uk

³ Management Science Group, Kent Business School, University of Kent, Canterbury, UK
v.l.spiegler@kent.ac.uk

⁴ Logistics Systems Dynamics Group, Cardiff Business School, Cardiff University, Cardiff, UK
linj17@cardiff.ac.uk

Abstract

The inventory and order based production control system (IOBPCS) is mainly a model of a forecast driven production system where the production decision is based on the forecast in combination with the deviation between target inventory and actual inventory. The model has been extended in various directions by including e.g. WIP feedback but also by interpreting the inventory as an order book and hence representing a customer order driven system. In practice a system usually consists of one forecast driven subsystem in tandem with a customer order driven subsystem and the interface between the two subsystems is represented by information flows and a stock point associated with the customer order decoupling point (CODP). The CODP may be positioned late in the flow, as in make to stock systems, or early, as in make to order systems, but in any case the model should be able to capture the properties of both subsystems in combination. A challenge in separating forecast driven from customer order driven is that neither the inventory nor the order book should be allowed to take on negative values, and hence non-linearities are introduced making the model more difficult to solve analytically unless the model is first linearized. In summary the model presented here is based on two derivatives of IOBPCS that are in tandem, and interfaces between them related to where the demand information flow is decoupled and the position of the CODP.

Keywords: IOBPCS, CODP, System dynamics.

1 Introduction

Supply chain management, as we know it today, has developed over several decades. In the past few years, successful businesses have moved from mass-production to customization and therefore their supply chain strategies have become more customer-driven (Christopher and Towill, 2000) or even customer-centric (Potter et al., 2015) instead of product-driven. Moreover, given the need of modern supply chains for surviving and thriving in turbulent and volatile environments caused by reduced product life cycle, increased demand for customized products and services and constant changes in the marketplace, agility became a key capability to be attained (Braunscheidel and Suresh, 2009).

On the other hand, due to pressures for leaner supply chains focus has been given to determining Minimum Reasonable Inventory (MRI) (Grünwald and Fortuin, 1992). In this way, special attention has been given to issues such as lot sizing, buffers and/or safety stock determination and improving forecasting accuracy (Dudek and Stadtler, 2005; Gunasekaran et al., 2004).

To combine these seemingly contradictory developments has triggered interest in finding a competitive balance between cost efficiency and customer responsiveness (Chopra and Meindl, 2013). This balance is also known under different names such as leagility (Naylor et al., 1999) that combines lean (cost efficiency) with agility (customer responsiveness) to create a competitive whole. The interface between lean and agile in this setup is the customer order decoupling point (CODP) and this is an important enabler for identifying a structural model that can be used for outlining a dynamic model suitable for dynamic analysis. Similar patterns can also be found in the discussion on how to balance efficiency and effectiveness (Wikner, 2014).

In memory of the originator of the IOBPCS family, Prof. Denis R. Towill, 1933-2015.

Consequently, many companies have changed their production policies to hybrid make-to-stock (MTS)/make-to-order (MTO) environments to attain the advantages of both pure systems (Kalantari et al., 2011), but decisions are often taken without the support of a rational model (Perona et al., 2009). The literature reports several industrial cases adopting this combined system, such as in the steel industry (Denton et al., 2003; Kerikkanen 2007; Perona et al., 2009), food production and processing organisations (van Donk, 2001; Soman et al., 2004, Soman et al., 2007), the chemical industry (Sharda and Akiya, 2012), an agricultural machines manufacturer (Köber and Heinecke, 2012), a plastic production firm (Rajagopalan, 2002), the timber industry (Yáñez et al., 2009), the metal processing industry (van Donk and van Doorne, 2015), the automobile industry (Choi et al., 2012), the electronic industry (Gupta and Weerawat, 2006) and the IT industry, such as Dell Computer Corporation (Serwer, 2002). These studies addressed many practical issues arising from the hybrid production system, for instance determining which products should be manufactured to stock and which ones on order, where to locate the CODPs, the annual quantity of orders to commit in the MTS and when to accept an order in the MTO and how to allocate capacity and buffer levels. However, although providing great insights into how forecast driven (FD) subsystem are decoupled from the customer order driven (CD) subsystem in practice, many of these case studies provide very little basis for scientific generalization.

In order to overcome these limitations, a number of analytical research papers have been published (Lee and Tang, 1997; Carr and Duenyas, 2000; Gupta and Benjaafar, 2004, Sun et al., 2008; Kaminsky and Kaya, 2009; Kalantari et al., 2011; Renna, 2015) using multi-domain methodology. However, these studies have mainly addressed static cost- and/or customer service-optimization problems considering different structuring models. Few research studies have taken a dynamic perspective to explore the effects of different policies in the hybrid MTS/MTO approach on the system responses, with the exception of Wikner et al. (2007); Hedenstierna and Ng (2011) and Choi et al. (2012). Wikner et al. (2007) presented a system dynamics simulation model to analyse the supply chain dynamics downstream of the CODP. Although their work does not undertake any experiment of the FD and CD supply systems in tandem, the model could potentially be extended and used for the dynamic analysis of decoupled systems, but it lacks the mechanism for integration between the two models.

By decoupling generic FD and CD models, Hedenstierna and Ng (2011) evaluated the dynamic consequences of shifting the position of the CODP and found that the ideal position depends on the frequency of demand. However, their model is simple and linear lacking more realistic representations, such as capacity constraints and availability of material. Choi et al. (2012) developed a system dynamics simulation model from Lee and Tang's (1997) model and their experiences gained through a case study in a Korean automobile manufacturer. In contrast to Hedenstierna and Ng (2011), their model represents complex variable relationships but their simulation results are limited to Korean global automobile companies.

The purpose of this paper is therefore to develop a generic dynamic model of a production control system that combines FD and CD approaches to balance cost efficiency and customer responsiveness. By merging the theories of structural modelling for positioning of the decoupling points, such as the CODP, and dynamic modelling for understanding systems responses, we deduct a hybrid model for dynamic analysis. The developed model is benchmarked against known system archetypes and then verified via system dynamics simulations.

After giving a brief overview in Section 2 of the fundamental foundations of our paper, namely existing research on structural and dynamic modelling, we then proceed to develop the new conceptual model that combines FD and CD approaches. Building on previous research highlighted in Section 2, Section 3 provides a new dynamic model for a FD system while Section 4 presents a new dynamic model for the CD element. Then Section 5 gives the dynamic

analysis, including verification, undertaken for different scenarios that combine the two sub-systems by exploiting the decoupling point. Finally, Section 6 concludes with the implications of our research including highlighting avenues for further research.

2 Theoretical framework

The objective here is to combine structural modelling, for positioning of decoupling points in the flow, with dynamic modelling that captures key dynamic properties. Structural modelling is based on a flow perspective and on the assumption that a continuous and level flow in terms of volume and mix represent the optimal state. In practice this is rarely the case and discontinuities of the flow, related to decoupling points, introduce complexity and this is the target of structural modelling. Dynamic modelling, on the other hand, takes a certain structural model as a point of departure for investigation of dynamic properties. The outcome of the analysis may be to either change the parameters used in a certain context or actually change some structural aspects of the model, but then still within the boundaries given by structural modelling. Structural modelling hence basically identifies a number of contexts, such as positioning of the customer order decoupling point, with given preconditions and dynamic modelling investigates the dynamic properties of the flow within such a given context.

2.1 Structural modelling: Decoupling thinking

Structural modelling based on decoupling points, here referred to as decoupling thinking, has been developed for decades in terms of inventory management and materials management. Particular focus on strategic decoupling points was introduced by Hoekstra and Romme (1992) in their seminal work with Philips where they outlined how to use the decoupling point that separates FD flow (sometimes also referred to as speculation driven) from CD flow (sometimes also referred to as commitment driven). This strategic decoupling point was later referred to as customer order decoupling point (CODP) by e.g. Giesberts and van der Tang (1992). The location of the CODP has implications on cost efficiency (Choi et al., 2012) and supply chain integration levels (van Donk and van Doorne, 2015; Wikner and Bäckstrand, 2011). A distinction between the actual driver and information about the driver was introduced by Mason-Jones and Towill (1999) in terms of the Information Decoupling Point (IDP) which was renamed to Demand Information Decoupling Point (DIDP) by Wikner (2014) to distinguish it from information decoupling related to availability of supply information such as available capacity. Information about available capacity may for instance be related to a having access to the load of resources at a supplier. The relation between CODP and DIDP was investigated by Olhager et al., (2006) in relation to the Fisher model (Fisher, 1997) resulting in recommendation of how to position the DIDP in relation to CODP and the concept of mediate demand. Since the CD flow is based on actual customer orders it is by definition necessary to position the DIDP upstream of the CODP, or possibly at the CODP. If DIDP is positioned upstream of the CODP the forecast used for the FD flow can be improved as it may be based on more up to date point of sales data.

The similarities between CD flow and services was highlighted by Sampson and Froehle (2006) and further developed by Wikner (2012) that identified three subsystems where the FD subsystem is goods based, the CD subsystem is service based and the consumption subsystem, finally, is driven by customer value and based on product which is a combination of goods and services, see Figure 1. As services cannot be inventoried and should not be produced to forecast the supply system upstream of the CODP only relates to goods. On the other hand, services are associated to processes that are performed to customer demand and consequently the flow downstream of the CODP is referred to as service based. The delivery lead-time represents the time to execute the complete order fulfilment process and the supply lead-time is the complete cumulative lead-time to perform all supply activities (Shingō, 1989, referred to these two lead times as D and P). An important observation is that the strategic inventory positioned at the

CODP represents the interface between the two supply systems and that the DIDP should be positioned upstream of that interface. In addition, the goods based system is materials focused whereas the service based subsystem is capacity focused and this distinction is not reflected in the original system dynamics model outlined in the next section.

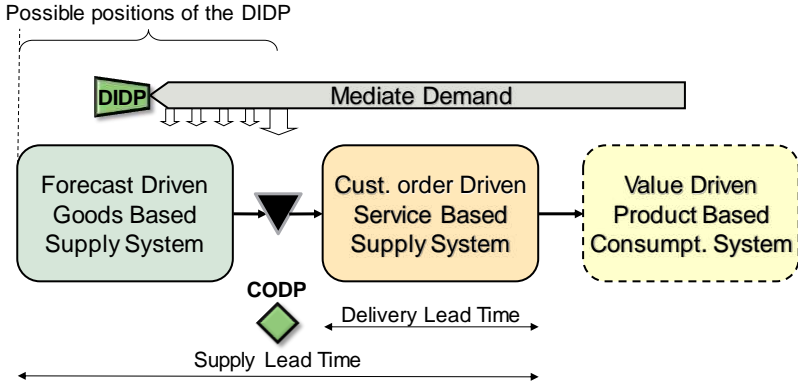

Figure 1. Framework for structural modelling using decoupling points (source: authors based on Wikner, 2012)

In a structural context it is important to be careful when using the terminology of MTS and MTO. These acronyms are used with two different meanings in the literature. In most cases on e.g. operations strategy MTS refers to make to stock in the sense that all activities in the system are performed to forecast, i.e. CODP positioned late in the flow. Correspondingly MTO refers to when all activities in the system are performed to customer orders i.e. CODP positioned early in the flow. In this context assemble to order (ATO), or a similar setting, is used to denote a system where some activities are performed to forecast (upstream of the CODP) and some to customer order (downstream of the CODP). The two acronyms MTS and MTO are however also used in the context of e.g. leagility, CODP, or postponement where MTS is used to denote the FD activities upstream of the CODP and MTO the CD activities downstream of the CODP. With this approach the former ATO system would be referred to as a MTS/MTO hybrid. In summary one perspective is to use MTS and MTO for a particular position of the CODP and the other use MTS and MTO to refer to flow in relation to the CODP. For example, mixing these two approaches MTS can denote both CODP positioned early and the activities that are upstream of the CODP. To avoid this potential confusion when using the terminology of MTS and MTO we use FD and CD to represent system with different drivers and therefore the activities upstream and downstream of CODP respectively. MTS and MTO then only refers to systems with a particular position of the CODP (late or early). Using these definitions ATO would correspond to a FD/CD hybrid with an internal CODP as shown in Table 1, where X indicates that a system with a particular position of the CODP would include the corresponding driver. In addition there are systems where FD and CD activities are performed on the same resources and this is sometimes referred to as hybrid MTS/MTO but also as a resource based customer order decoupling zone (CODZ) (Wikner, 2014). This combination is, however, not used here as we are outlining a fundamental model for a CODP context where resources are not shared between CD and SD.

	Driver upstream of CODP (FD)	CODP	Driver downstream of CODP (CD)
CODP positioned early (MTO)	-	X	X
CODP positioned late (MTS)	X	X	-
CODP positioned internally (ATO)	X	X	X

Table 1. Two different use of the acronyms MTS and MTO (source: authors)

2.2 Dynamic modelling: Inventory and order based production control system (IOBPCS)

Dynamic modelling refers to modelling that captures the dynamic properties of the flow and a frequently used model for this purpose is the original IOBPCS model (Towill, 1982). The model has been extended in several directions such as when also work in process (WIP) is explicitly controlled and this model is referred to as Automated Pipeline, Inventory and Order Based Production Control System (APIOBPCS) (John et al., 1994). The APIOBPCS was further extended to include variable inventory targets, the APVIOBPCS (Dejonckheere et al., 2003), which are more representative of the Order-Up-To replenishment policy, see Figure 2. These models are well recognized in the supply chain literature and have been used to investigate different phenomena, such as the bullwhip effect (Disney and Towill, 2003; Disney et al., 2004), the backlash effect (Shukla et al., 2009), the impact of production and freight capacity constraints (Cannella et al., 2008; Spiegler and Naim, 2014) and assessment of supply chain resilience (Spiegler et al., 2012).

The APVIOBPCS model is basically a model of decision making and shows the impact of feedforward and feedback of information used in deciding on the order rate (ORATE) to be released to production, which is represented by a lead-time before the output is produced as a completion rate (COMRATE). The feedback concerns the inventory in terms of actual inventory (AINV) and actual work in process (AWIP), the latter also referred to as goods in the “pipeline”. The key feedforward is the forecasted consumption rate (based on CONS) and CONS also withdraws from AINV. In addition the desired inventory (DINV) and desired work in process (DWIP) are estimated to be compared with AINV and AWIP in deciding on the ORATE released to production.

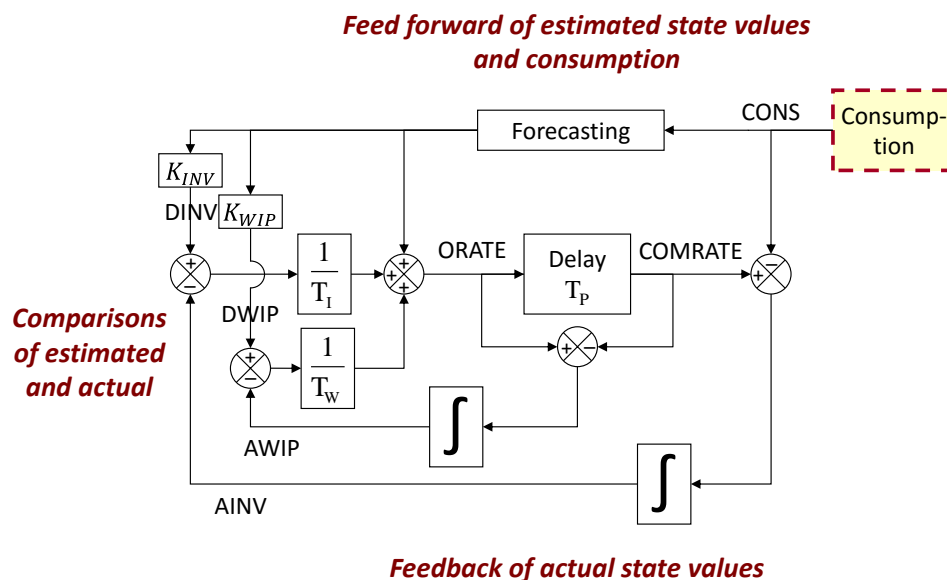

Figure 2. Framework for dynamic modelling using Automatic Pipeline, Variable Inventory and Order Based Production Control System (APVIOBPCS) (source authors: based on Sarimveis et al., 2008)

An important control variable in IOBPCS is the inventory level in terms of AINV and consequently the model is usually associated with MTS scenario. If the inventory is depleted and becomes negative the logic is instead based on backorders, which is a kind of MTO scenario. Even if backorders represent a MTO scenario it should not be confused with MTO systems that are designed to handle an order book and produce to customer order, which could also involve customized products. In this sense the IOBPCS model is a hybrid MTS and MTO system but unfortunately these two modes are not separable as only one state variable captures both the

inventory on hand and the amount of backorders. Next these two scenarios are separated and a new FD model and a new CD model are derived.

3 Modelling forecast driven supply system

The forecast driven and goods based supply system (FDGBSS) can represent a MTS system that produces based on forecast to replenish finished goods inventory (AINV). The model suggested here is based on APVIOBPCS but modified to be suitable for a CODP-based approach. FDGBSS systems are based on material and the key interface with the customer is through the finished goods inventory. If inventory is available, deliveries are assumed to take place in immediate response to the demand rate, $DRATE_{FD}$ (corresponding to CONS in APVIOBPCS) and in case inventory is not available, the customer requirements turn into backorders that are delivered later. This distinction between inventory and backorder is not possible to make in a linear context, such as the APVIOBPCS model of Figure 2. In this model backorder is the negative inventory and a mechanism is necessary to separate the positive inventory ($AINV_+$) from the negative inventory, which with a reversed sign is referred to as the actual backorders (ABO_+).

3.1 Linear modelling of forecast driven supply system

Linear models can therefore basically only be used for FDGBSS when there are no backorders. This can be achieved by raising the DINV, of the model in Figure 2, to such a level that no backorders occur but this would also generate high inventory levels and require that the minimum AINV can be estimated in advance to be able to set DINV sufficiently high. In Figure 3 this would mean that $A = 0$ and that the system basically would be assumed to provide any amount of material with no delay.

3.2 Non-linear model of forecast driven supply system

As indicated above the linear model cannot differentiate backorders from negative inventory and hence the DINV should be set sufficiently high to eliminate the risk for backorders in relation to demand rate $DRATE_{FD}$. However, if backorders are present, the availability of materials would be finite. This corresponds to when $AINV < 0$ and a mechanism must be used to separate $AINV > 0$ from $AINV < 0$. The system in Figure 3 is based on that the orders are aiming for a balance between the actual inventory (AINV) and the desired inventory (DINV). In this case block A is the function $A = -\text{Min}\{AINV, 0\}$ and basically works as a separator of $AINV_+$ and ABO_+ which means that the $AINV_+$ cannot be less than zero if $B = 1$ and ABO_+ cannot be less than zero. From a control perspective it is still possible to use negative AINV ($AINV_+ = AINV$) in the decision logic to decide $ORATE_{FD}$ and this is achieved by setting $B = 0$. A negative AINV would make the system more responsive but potentially also less stable since removing negative values of AINV is like adding a damping function to the dynamics. By taking the derivative of ABO_+ the backorder rate ($BORATE_{FD}$) is obtained and it represents the change in ABO_+ . If $BORATE_{FD}$ is positive the $DRATE_{FD}$ cannot be fulfilled since backorders are increasing and only part of the demand ($DRATE_{FD} - BORATE_{FD}$) can be fulfilled. When $BORATE_{FD}$ is negative the deliveries are actually greater than the $DRATE_{FD}$ and ABO_+ is decreasing. Negative $BORATE_{FD}$ must however be handled carefully since it represents late deliveries. Hence the difference $DRATE_{FD} - BORATE_{FD}$ represents the actual deliveries taking place at each moment in time. Note that AWIP cannot be negative even if the input is a difference between two values (rates). Since the cumulative value of what has been input is less than the cumulative value of the output AWIP can only take on positive values, unless the rates themselves have negative values.

In summary two different material policies can be identified where B can be set to either $B = 0$ or $B = 1$ depending on the desired dynamic properties:

- Infinite material: No backorders: ($A = 0$)
- Finite material: Backorders are separated from inventory: $A = -\text{Min}\{AINV, 0\}$

In memory of the originator of the IOBPCS family, Prof. Denis R. Towill, 1933-2015.

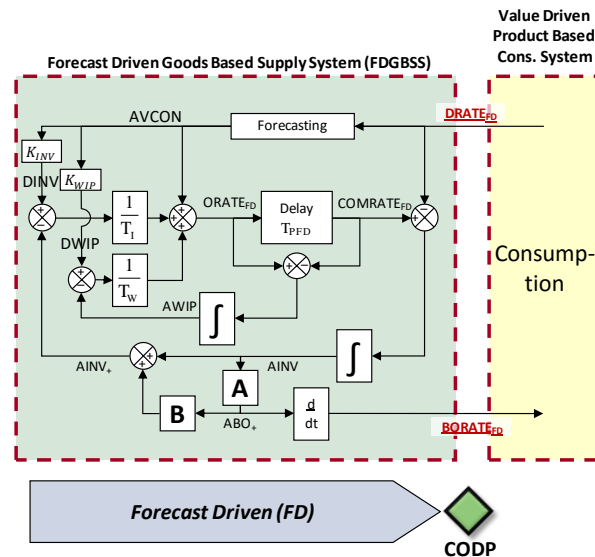

Figure 3. Forecast driven goods based supply system (FDGBSS) (source: authors)

4 Modelling customer order driven supply system

Customer order driven service based supply system (CDSBSS) can represent a MTO system whereas the original IOBPCS model is, as the name indicates, based on MTS where inventory is the key state variable. It is however possible to use IOBPCS in a MTO scenario if AINV is interpreted as a negative order book. By also removing the forecast function (setting $T_A=0$ in Appendix B) the customer orders actually drive production. In addition, DINV must have a negative value representing the target order book (with a minus sign) to keep AINV negative. Few attempts have been made to extend the IOBPCS model to represent a MTO scenario where the activities are CD. Wikner et al. (2007) developed an order book based model that required a desired order book to be set and the control mechanism was based on keeping the actual order book in line with the desired order book. The purpose here is to apply a slightly different approach and to extend this work to prepare for a CODP-based scenario. The order book per se is not necessary for controlling the system and instead the emphasis is on providing information on the deliveries in relation to the demand and focus on late deliveries in relation to a given lead-time. The model will therefore be updated and instead of focusing on the actual order book the emphasis is on the deviation between the demand rate and the completion rate, i.e. the changes in the order book.

The model suggested here is capacity focused and in this sense conceptually only remotely related to the IOBPCS-family of models, which are material focused, and may hence be named Capacity and Order Based Production Control System (COBPCS). The actual order book (AOB) consists of all customer orders received but not yet delivered to the customers. The AOB is not used in the decision logic of the model but only generated for other purposes such as validating the model. The Backlog (BL), on the other hand, consists of all customer orders that have been received but not yet released to production. The waiting time for the customer hence basically consists of two parts: Administrative lead-time and production lead-time. The administrative lead-time is the delay from when the customer has released an order to when capacity is allocated to the customer order and production is initiated. In the original IOBPCS the production lead-time is modelled using the standard assumption of Towill (1982), which can be interpreted as the expected dynamic behaviour of the production unit (Wikner, 2003). In COBPCS there is no feedback about deviations between ORATE and COMRATE and hence there is no logic available to recover any lost production. This logic can of course be added by introducing an additional feedback loop but since the order release is based on available capacity the queueing, which could result in varying lead times, can be kept stable. For clarity

of the model, and to keep it as simple as possible, this feedback control is not included and hence the production lead-time must be modelled as a pure delay. This comes as no surprise as the COBPCS is based on capacity and the ORATE actually represent what the system is expected to be capable of processing which means that no smoothing of the production lead-time needs to be included for that purpose.

The model of Figure 4 consists of two key decisions where C represents capacity management, and D represents backlog management in terms of how the backlog is prioritized. The two decisions represent a two phase capacity strategy where the long term agility (in line with Wikner et al., 2007) is represented by C in Figure 4 and the short term agility by D. C basically represents a lag strategy using the terminology of Hayes and Wheelwright (1984). The backlog strategy, related to D in Figure 4, represents how the backlog is handled by the system from a capacity perspective. The order book of customer orders consists of three components (three different states in the model): Queue of orders not released immediately due to the capacity strategy (not enough capacity available), backlog in the system delaying release of orders, and AWIP during transformation lead-time, where the latter is not explicitly modelled here.

4.1 Linear modelling of customer order driven supply system

The model of Figure 4 is linear in all components explicitly included. In addition, the capacity strategy corresponding to C is suitable for linear representation in that the response to the requirements rate (REQRATE) is readily represented by a first order delay to create Smoothed (REQRATE) that provides an upper boundary for the required capacity which is based on the demand rate ($DRATE_{CD}$) and backlog adjustment. A slow response corresponds to a more level strategy with smoother dynamics and a fast response corresponds to a more agile strategy with more volatile dynamics. The available capacity is represented by the capacity rate (CAPRATE). Also the backlog strategy is modelled in a linear fashion by assuming that a fraction ($1/T_{BL}$) of the backlog is added to the capacity available based on the capacity strategy. Depending on D the customer orders in the backlog can be handled in two ways. If $D = 0$ the backlog customer orders are added to the new customer orders, resulting in REQRATE, to compete for capacity whereas $D = 1$ means that additional capacity is added to the order rate ($ORATE_{CD}$) to handle the backlog and this can be interpreted as e.g. use of over time to recover the backlog.

4.2 Non-linear modelling of customer order driven supply system

Non-linear modelling provides further opportunities to capture important characteristics of the CD system. The capacity strategy can be modelled using a separate state variable for the limited capacity rate (CAPRATE), potentially limited by a capacity constraint (CAPCON), and decide on the CAPRATE as $\text{Min}\{\text{CAPCON}, \text{Smoothed}(\text{REQRATE}), \text{REQRATE}\}$, which means that either CAPCON or Smoothed(REQRATE) may constrain the rate of orders that can be processed according to the capacity strategy. If capacity is finite without possibility to temporarily increase capacity to cover for a fraction of the backlog the fraction of the backlog is added to the new customer orders $DRATE_{CD}$ ($D = 0$). On the other hand, if capacity is added to handle recover of the backlog, it is added to the order rate ($ORATE_{CD}$) as in the linear case ($D = 1$).

In summary three different capacity policies can be identified:

- Infinite capacity (agile): No capacity limit is used and $C = 1$ which means that all orders are delivered within the production lead-time (no backlog is created leaving D with no impact, i.e. it can take on any value). This means that $CAPRATE = REQRATE$
- Semi-finite capacity: The standard capacity of CDSBSS is finite and adjusted over time ($C = \text{Min}\{\text{Smoothed REQRATE}, \text{REQRATE}\}$) but capacity is added to handle a fraction of the backlog ($D = 1$).

- Finite capacity (Level): Capacity of CDSBSS is finite ($C = \text{Min}\{\text{CAPCON}, \text{Smoothed}(\text{REQRATE}), \text{REQRATE}\}$) where CAPCON is the maximum capacity available and no additional capacity is allocated separately to cover for the backlog ($D = 0$).

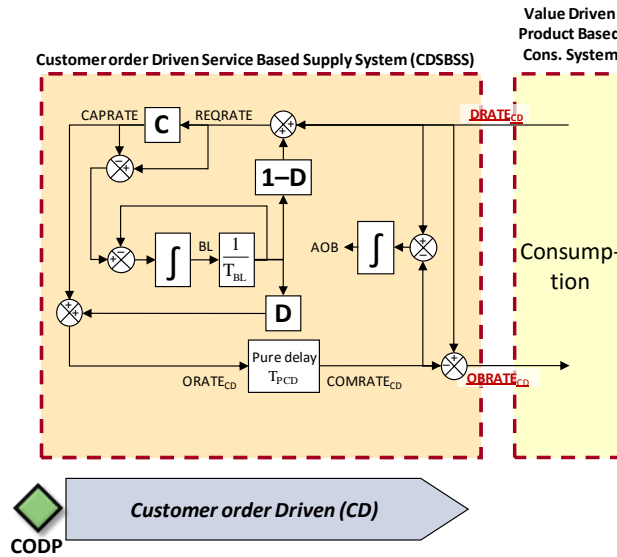

Figure 4. Customer order driven goods based supply system (CDSBSS) (source: authors)

5 Modelling forecast driven and customer order driven supply system in tandem

The CODP based production control system (CODPBPCS) is a combination of FDGBSS and CDSBSS. The two supply systems in tandem work as two separate entities from a supply perspective except for when insufficient inventory is available, i.e. backorders, in FDGBSS which then affects the receiving supply system (CDSBSS). In case of backorders the CDSBSS should be influenced in the sense that it is not possible to deliver according to the original demand (related to DRATE_{CD}) and the ORATE_{CD} is reduced by the amount corresponding to the backorders from the FDGBSS as shown in Figure 5 where BORATE_{FD} is input to CDSBSS. A positive BORATE_{FD} represents a growing ABO^+ which means that deliveries are smaller than requested by DRATE_{FD} and hence ORATE_{CD} is reduced. Once BORATE_{FD} is negative it means that ABO^+ is shrinking and hence deliveries are greater than requested by DRATE_{FD} and the backorders are recovered and hence more material is provided to the CDSBSS. The availability of the demand information is represented by the position of the DIDP and two significant positions of DIDP can be identified that provide limited demand transparency or full demand transparency. It is important to notice that even if the capacity strategy is set to finite capacity is actually added to cover for using the late material.

5.1 CODPBPCS with limited demand transparency

Demand information refers to information about actual sales, which is here represented by the demand rate related to customer orders, DRATE_{CD} . Information about customer orders must be available for all of the CDSBSS since customer orders drive that supply system. In terms of CODPBPCS this means that the DIDP is positioned between the two supply systems as shown in Figure 5. The DIDP is technically positioned at the right of the forecasting block but in practice information about actual demand in the market (DRATE_{CD}) is not known within the FDGBSS where DRATE_{FD} is based on the material required at the CODP through CAPRATE and, in case $D=1$, also adjustment of the backlog. Hence, the FDGBSS is only driven by forecast based on expected future requirements from the CDSBSS and the DIDP is therefore positioned between the two supply systems as shown in Figure 5.

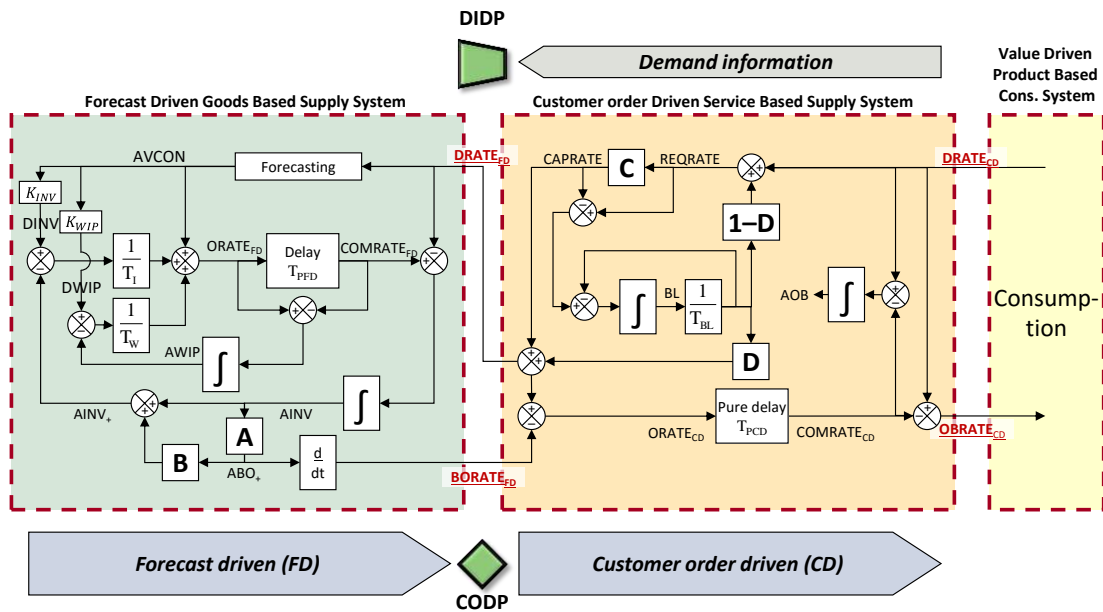

Figure 5. CODPBPCS with limited demand transparency (source: authors)

5.2 CODPBPCS with full demand transparency

By increasing availability of actual demand even upstream of the CODP it is possible to improve the quality of the forecast in FDGBSS. In terms of CODPBPCS the DIDP is then positioned upstream of both supply systems to provide full demand transparency as shown in Figure 6. The sales information related to consumption ($DRATE_{CD}$) is made available to the FDGBSS, which is a common method to reduce the bullwhip effect (Hosoda et al., 2008). But, since the requested delivery lead-time only covers activities performed by the CDSBSS the demand information cannot be used to drive the transformation of the FDGBSS directly. Instead it is used as input to forecasting (and smoothing for DWIP and DINV) resulting in a forecast based on actual market demand for delivery to the end customer, represented by $DRATE_{CD}$, rather than the requirements from the CDSBSS, i.e. CAPRATE and potentially some adjustments to the backlog if $D = 1$.

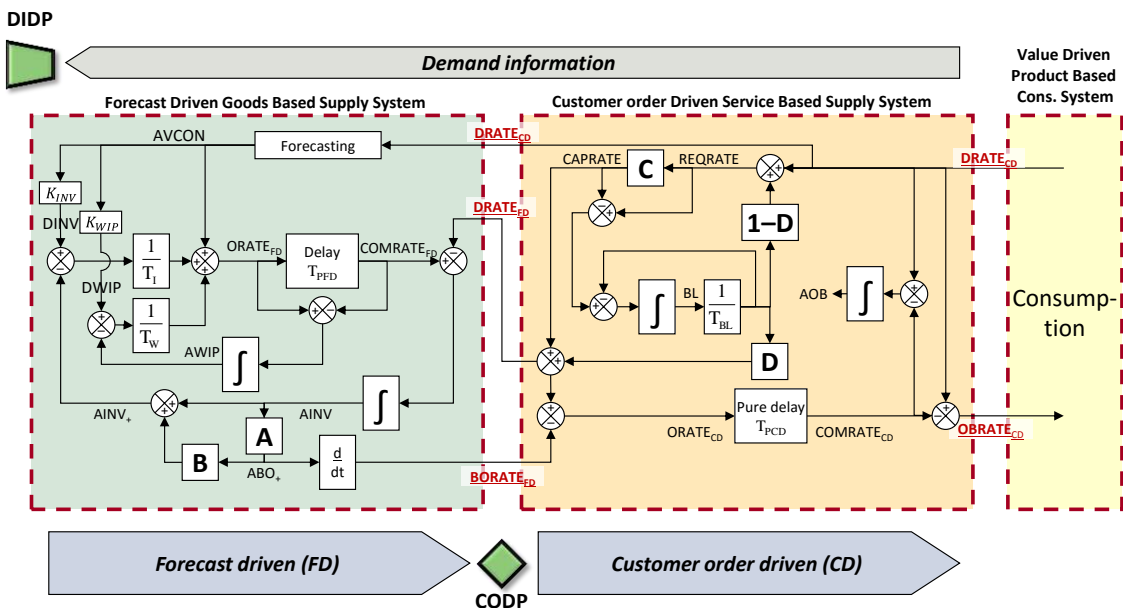

Figure 6. CODPBPCS with full demand transparency (source: authors)

5.3 CODPBPCS properties

CODPBPCS has in total four different highlighted management decisions (A, B, C, and D, in Figure 5 and Figure 6) that can be represented as discussed above and summarized as in Table 2. Table 2 shows that basically there are only two non-linearities in total: one related to finiteness in material and one related to finiteness in capacity.

Type of strategy	Linear model	Non-linear model
Backorder management (A and B)	A=0 B has no function	$A = -\text{Min}\{A_{INV}, 0\}$ B = 0 or B = 1
Capacity management (C)	C = 1 or Smoothed (REQRATE)	$C = \text{Min}\{CAPCON, \text{Smoothed}(REQRATE), REQRATE\}$
Backlog management (D)	D = 0 or D = 1	D = 0 or D = 1

Table 2. Linear and non-linear versions of the three key modelling components (source: authors)

In addition, Table 3 suggests a system classification for the CODPBPCS model archetypes where A and C are the potential non-linear blocks and B and D represent different types of scenarios and these two latter options are the baseline for variants investigated below.

Block	Transfer function	Block	Transfer function
A	0 or $-\text{Min}\{A_{INV}, 0\}$	C	1 or $\text{Min}\{CAPCON, \text{Smoothed}(REQRATE), REQRATE\}$
B	0 or 1	D	0 or 1

Table 3. System classification for CODPBPCS (source: authors)

To summarize the model CODPBPCS, it is basically a combination model of two types of systems, a FDGBSS followed by a CDSBSS. As a consequence, the CODPBPCS inherits the properties of each supply systems. When they are combined the FDGBSS provides materials to the CDSBSS, which is capacity focused as it strives to provide delivery to the customer within a requested delivery lead-time. Six different types of CODPBPCS can be identified by combining the properties of FDGBSS and CDSBSS as in Table 4, which is a combination of the conclusions from the sections above on FDGBSS and CDSBSS. Of these six intersections the models in Figure 5 and Figure 6 can represent all six combinations depending on how the parameters A, B, C, and D are selected. In addition, the extent of demand transparency can be included which would result in a third dimension of the matrix in Table 4.

	Infinite capacity (IC) (C=1)	Semi-finite capacity (SFC) ($C = \text{Min}\{\text{Smoothed}(REQRATE), REQRATE\}$, D=0/1)	Finite capacity (FC) ($C = \text{Min}\{CAPCON, REQRATE, \}$, D=0/1)
Infinite material (IM) (A=0, B=0/1)	IM-IC	IM-SFC	IM-FC
Finite material (FM) ($A = -\text{Min}\{A_{INV}, 0\}$, B=0/1)	FM-IC	FM-SFC	FM-FC

Table 4. Six different types of CODPBPCS (source: authors)

The CODPBPCS model is formulated in terms of production but it is important to note that it is a general model based on value adding transformation and that part of the flow is performed on speculation to forecast and the other part is performed on commitment to customer order.

In memory of the originator of the IOBPCS family, Prof. Denis R. Towill, 1933-2015.

The actual transformation is referred to as production above, but may concern for example administration, production, distribution or transportation and the actual value adding transformation is only modelled in terms of the lead-time required to perform the transformation.

5.4. Dynamic performance of the CODPBPCS

Having developed the model, it is important to verify the logic and correctness of the model (Sargent 2013). This is done by simulation based on difference equations implemented on a spreadsheet and we do not show the full verification results but formulate some of the simulation analysis. Table 5 presents the verification result of the CODPBPCS model. The IOBPCS family (Towill 1982; John et al. 1994; Dejonckheere et al. 2003; Winker et al. 2007) are adopted to reproduce the dynamic behaviour of the CODPBPCS system including using the same system parameters/extreme values to verify the model. The verification result shows that the dynamic behaviour of CODPBPCS model is consistent with the IOBPCS family in responding to a step increase.

Verification test	Details	Verification process	Verification result
Family member and Parameters	Behaviour reproduction for cognate system (i.e. the IOBPCS family) and be consistent with system data and description	<ol style="list-style-type: none"> 1. The parameter settings in original APIOBPCS (John et al. 1994) are utilized, i.e. $T_{PFD} = T_i = 8$, $T_a = T_w = 16$, to simulate the linear version of the FDGBSS model ($B=0$ and targeted AINV is set as fixed at 100). 2. As the CDSBSS model is only remotely similar to the IOBPCS family and the dynamic behaviour cannot be reproduced. Alternatively, we check whether results of initial value/final value of the CDSBSS system are consistent with Wikner et al. (2007) via using the same parameter settings, i.e. $T_{PFD} = 4$, $T_C = 6$, $T_{BL} = 4$, step increase = 50% with initial demand = 100 	<ol style="list-style-type: none"> 1. Dynamic behaviour of the FDGBSS model is consistent with the original APIOBPCS e.g. maximum overshoot/undershoot, rising time and setting time. 2. The result of initial value and final value of system variables are consistent with Wikner et al. (2007), i.e. $AOB_{final} = 600$, $ORATE_{final} = COMRATE_{final} = 150$
Boundaries and Structure	Include all important factors and be consistent with system description	As the CODPBPCS model we developed is conceptual for the purpose of scientific generalization, we utilize Yang et al. (2004), Wikner et al. (2007) and Dejonckheere et al. (2003) to cross-check the consistency of the system framework and important factors of the CODPBPCS model	<ol style="list-style-type: none"> 1. The system description of CODPBPCS model is consistent with final manufacturing/ assembly to order system characterized by leagility, Mass customization (Yang et al 2004). 2. All important factors are included in the FDGBSS and CDSBSS models cross-checked by corresponding APVIOBPCS (Dejonckheere et al. 2003) and VOBBPCS models (Wikner et al. 2007) i.e. inventory-based variables in the FDGBSS system and capacity-based factors in the CDSBSS.
Extremities	Model is logical for extreme values	<ol style="list-style-type: none"> 1. We check whether the FDGBSS system is consistent with the IOBPCS archetype if $\frac{1}{T_w} = \infty$ (remove the WIP feedback loop) 2. We increased the value of T_A, T_I, and T_{BL} to extreme conditions to see whether the dynamic behaviour of the CODPBPCS model is still what we expected 	<ol style="list-style-type: none"> 1. The dynamic behaviour of the FDGBSS system is consistent with corresponding performance in the original IOBPCS if the WIP feedback loop is removed 2. The extreme value of T_A, T_I, and T_{BL} will lead to the expected dynamic performance in responding a step demand increase. For example, the infinite T_I will remove the inventory

In memory of the originator of the IOBPCS family, Prof. Denis R. Towill, 1933-2015.

			feedback loop, which result the permanent inventory drift in responding a step increase as expected.
--	--	--	--

Table 5. Model verification test, adapted by Spiegler et al. (2016) based on Sterman (1984)

Even though complex analysis of the CODPBPCS model through various techniques (e.g. linear/non-linear methods) is beyond the scope of this paper, it is important to understand the basic dynamic behaviour of such system under different management policies, particularly for the nonlinear policies (A and C) in which materials are finite and backlogs are created in the upstream FDGBSS system to represent the real value-added scenarios. Thereby FM-SFC of six different type of the CODPBPCS model is selected for simulation process. FM-FC (i.e. $B = \text{Min}\{\text{CAPCON}, \text{Smoothed}(\text{REQRATE}), \text{REQRATE}\}$) is not considered in this study, as constrained capacity is limited to investigate the overshoot behaviour or cycle-based demand patterns such as sinusoidal demand. For the purpose of exploring the comprehensive dynamic properties of the CODPBPCS system, a step change (70% increase) is utilized as the input. The size of the step is selected as to generate backorder of materials for FDGBSS given the selected DINV. Step change as the input is easily visualized and its responses are also easily interpreted (John et al. 1994), also, the step increases give rich information for the dynamic behaviour of the system (Coyle 1977).

The simulations basically focus on the planning and control system with the combination of FDGBSS and CDSBSS. The lead-time ratio is set to 4:2 ($T_{\text{PFD}}:T_{\text{PCD}}$) to represent the long production cycle in the FD system while short customer waiting time in the CD system. The two demand information management policies, as outlined above, are compared: limited demand transparency and full demand transparency. For each scenario, we particularly compare the changeable policies (i.e. B (0/1), D (0/1) and different information sharing strategy) to create the different dynamic properties of the CODPBPCS system. Thereby all other system parameters and policies are fixed and there are four simulation choices for each changeable policy as summarized in

Table 6. However, there are only eight different simulation scenarios in total because of four overlap of twelve simulation structures, i.e. compare different B/D decision policy by fixing other policies (see Table 6). We select one simulation scenario as the representative for each changeable policy to understand the impact of them on the dynamic behaviour, thus six of eight simulation scenarios are presented. Details of system parameter settings and difference equations used in the simulation can be seen in appendix B.

Changeable policies to be compared	Simulation experiment scenarios		Number of different simulation case
Compare Limited demand and Full demand transparency	B=1 and D=1 (selected)	B=1 and D=0	4
	B=0 and D=1	B=0 and D=0	
Compare B=1 and B=0	Limited demand transparency and D=1	Limited demand transparency and D=0	2 (2 of 4 are overlapping)
	Full demand transparency and D=1 (selected)	Full demand transparency and D=0	
Compare D=1 and D=0	Limited demand transparency and B=1	<u>Limited demand transparency and B=0 (selected)</u>	2 (2 of 4 are overlapping)
	Full demand transparency and B=1	Full demand transparency and B=0	

Table 6 The structure of the simulation process (source: authors)

The initial values are set to be the steady state of the system parameters with constant $DRATE_{CD}$ (100 units). Since the inventory in FDGBSS consists of both AINV and AWIP both must be included in the analysis, where

$$\begin{aligned} (AINV + AWIP)_{initial} &= DRATE_{FD,initial} \cdot K_{INV} + DRATE_{FD,initial} \cdot K_{WIP} \\ &= 100 \cdot 2 + 100 \cdot 4 = 600 \text{ units} \end{aligned} \quad (1)$$

In a similar way the initial value of AOB can be calculated as the number of customer orders received but not yet delivered at the initial demand rate:

$$AOB_{initial} = DRATE_{CD,initial} \cdot T_{PCD} = 100 \cdot 2 = 200 \text{ unit} \quad (2)$$

The final values of AINV+AWIP and AOB should only be dependent on the initial values and magnitude of the step increase since the only change is that a new stable rate is established as a consequence of the step. For AOB the relation is obvious as it represents the customer orders received but not yet delivered which at a steady state is only depending on the stable rate of demand, which increases by the step height times T_{PCD} , where

$$AOB_{final} = DRATE_{CD,final} \cdot T_{PCD} = 170 \cdot 2 = 340 \text{ units} \quad (3)$$

For the inventory the final values are slightly more complex to estimate in the general case since both AWIP and AINV together represent the total inventory in the system. To make a neutral contribution to $ORATE_{FD}$ the two must cancel out in the sense that $(DINV - AINV)/T_I + (DWIP - AWIP)/T_W = 0$ which means that the expected final inventory can be estimated once the other parameters are known. DINV and DWIP are easily estimated based on the final value of $DRATE_{FD}$ as:

$$DWIP_{final} = DRATE_{FD,final} \cdot K_{WIP} = 170 \cdot 4 = 680 \quad (4)$$

$$DINV_{final} = DRATE_{FD,final} \cdot K_{INV} = 170 \cdot 2 = 340 \quad (5)$$

The final value of AWIP is a consequence of the delay lead-time and is estimated as:

$$AWIP_{final} = DRATE_{FD} \cdot T_{PFD} = 170 \cdot 4 = 680 \quad (6)$$

Since in the results below $K_{WIP} = T_{PFD}$, AWIP will be in line with DWIP and then also the final value of AINV will be in line with DINV which can be shown by the balance equation above as:

$$\begin{aligned} AINV_{final} &= DINV_{final} + \frac{T_I}{T_W} (DWIP_{final} - AWIP_{final}) \\ &= 340 + \frac{4}{8} (680 - 680) = 340 \text{ units} \end{aligned} \quad (7)$$

This result can be found in all simulations performed here and the values are summarized in Table 7. This more comprehensive calculation of initial and final values are provided in particular for use in situations where $K_{WIP} \neq T_{PFD}$.

	Initial values	Final values
AINV, DINV	200, 200	340, 340
AWIP, DWIP	400, 400	680, 680
AOB	200	340

Table 7. Initial and final values for key state variables in the simulations (source: authors)

The simulation results below confirm the expected final values for AOB and AINV in the CODPBPCS system. Also important to notice is that AOB experience what can be referred to as a ‘camel effect’. This effect refers to the double ‘bumps’ that can be observed in the simulation results of AOB in all cases (see e.g. the plots of CDSBSSs in Figure 7). This is due to the sequence of impact from limited capacity available in the CD system followed by the constrained materials in the FD system (resulting in $AOB_{+} > 0$). Since the effect of limited capacity and limited materials normally do not coincide the AOB temporarily increases due to the constraints in materials and capacity respectively. Comparing the two demand management policies, the scenario with full demand transparency always performs better than with limited demand transparency in all eight cases as could be expected, see Figure 7 as an example. The improved forecasting quality through full demand transparency lead to that the FDGBSS system is more stable but at the same time less responsive than corresponding system under limited demand transparency. e.g. more AINV covering time (69 weeks compared 67 weeks), but longer AINV settling time (41 weeks compared 38 weeks) in relation to the demand rate. Regarding the CDSBSS system, the AOB step responses are better in the full demand sharing context than corresponding responses through implementing limited demand sharing in all cases. For instance, less overshoot of AOB (394 units compared 421 units) and shorter settling time (18 weeks compared to 19 weeks) are found in the context of full demand transparency. It should be noted here that delivery lead-time for both information sharing strategies will stabilize at the same final value (2 weeks) taken as the ratio $AOB(t)/DRATE_{CD}(t)$, due to the same final value of AOB as expected.

The simulation results also suggest that the availability of temporary capacity ($D=1$) leads to better step response of the CODPBPCS system compared to corresponding system without extra capacity ($D=0$) in all eight cases. For instance, Figure 8 shows the dynamic response of the CODPBPCS system to 70% step increase under $B=0$ and $D=0/1$ policies in the limited demand transparency environment. Performance indicators such as AINV and COMRATE experience less overshoot/undershoot at the expense of slightly longer settling time in the FDGBSS system as D increases. Moreover, the AOB step responses have better performance

with the increase of D in the CDSBSS system, i.e. less overshoot (414 units for $D=1$, 442 units for $D=0$), shorter recovery time (19 weeks for $D=1$, 20 weeks for $D=0$).

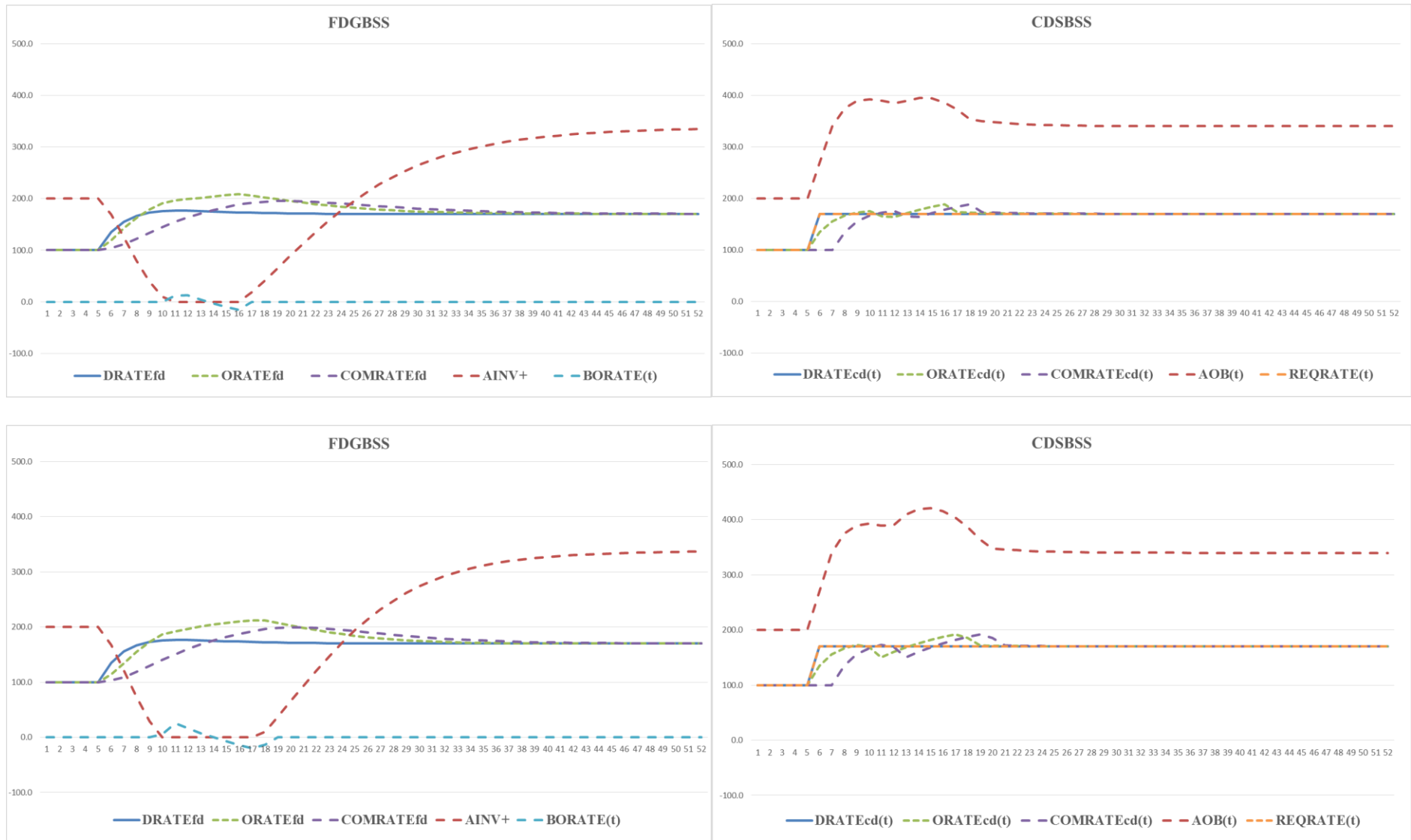

Figure 7. The 70% step response of the CODPBPCS system through full demand transparency (above) and limited demand transparency (below) under $B=1$ and $D=1$ (source: authors)

In memory of the originator of the IOBPCS family, Prof. Denis R. Towill, 1933-2015.

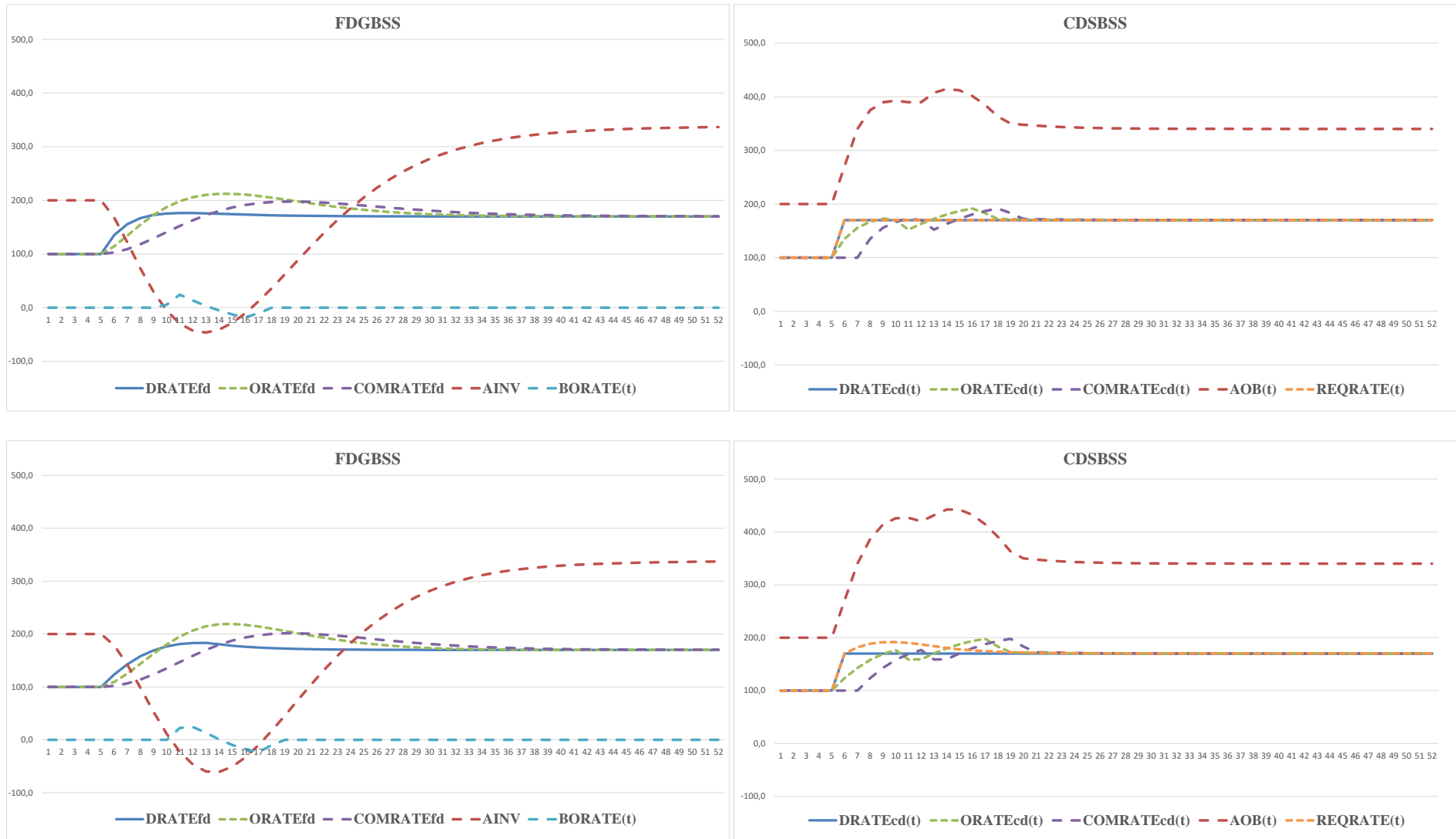

Figure 8. The 70% step response of the CODPBPCS system under $B=0$ and $D=1$ (above) and $B=0$ and $D=0$ (below) through limited demand transparency (source: authors)

In memory of the originator of the IOBPCS family, Prof. Denis R. Towill, 1933-2015.

Finally, the simulation shows that the B policy has a certain impact on the responsiveness of the FDGBSS system while little influence on the CDSBSS system can be found in all cases as expected. Figure 9, for example, shows that the FDGBSS system becomes more responsive but have more undershoot with the change of B from 1 to 0, i.e. AINV covering time increases from 69 weeks to 70 weeks while the undershoot of AINV increases from 24 units to 28 units.

It can be concluded that full demand transparency gives a better overall dynamic performance of the CODPBPCS system than limited demand transparency strategy, even though a trade-off between responsiveness and stability in the upstream FDGBSS system should be considered. The possible reason is that the improved forecasting quality enables the FDGBSS system to be more responsive in offering materials to handle the order backlog in the CDSBSS system, although the stability of the FDGBSS system, due to the effect of the feedback loop, have to be compromised.

Also, a similar ‘camel effect’ of AOB responses are observed in all eight simulation cases although only six of them are presented in Figures 6-8 above, due to the influence of initial constrained capacity in the CD system and the following AINV constraint in the FD system, which is consistent with the theoretical understandings that the two nonlinearities in the FD system (finite materials) and the CD system (finite capacities) have a direct impact on the dynamic behaviour of the CODPBPCS system. Furthermore, the level of capacity flexibility in the CD system is determined by the D policy and it is obvious that the availability of temporary capacity ($D=1$) always lead to better step responses of the CODPBPCS system due to the reduction of oscillations of REQRATE (input). However, a similar balance between responsiveness and stability of the FDGBSS system need to be justified as the change of D policy from 0 to 1. Furthermore, the B policy has the direct impact on the responsiveness of the FDGBSS system, while little influence is found for the CDSBSS system.

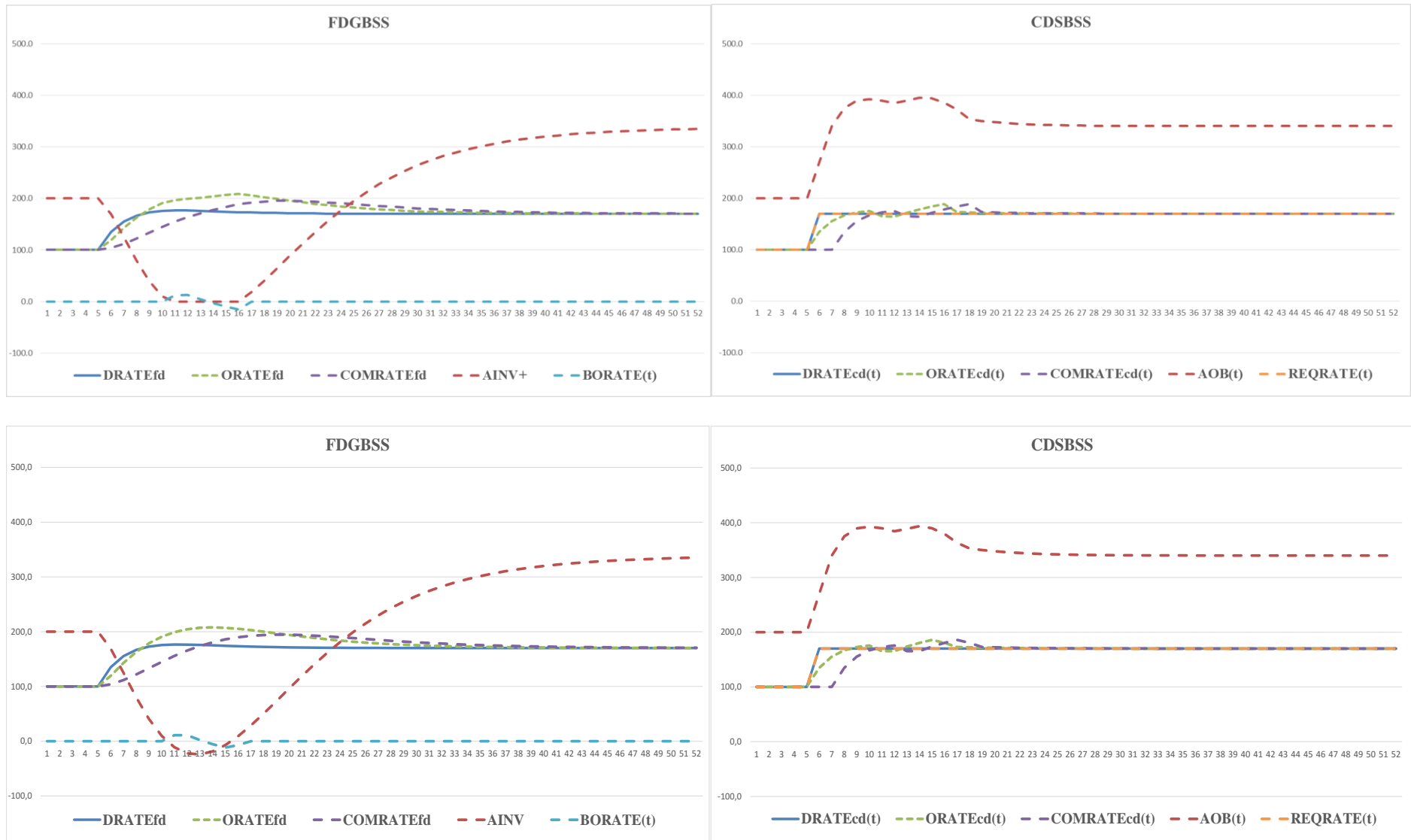

Figure 9. The 70% step response of the CODPBPCS system under $B=1$ and $D=1$ (above) and $B=0$ and $D=1$ (below) through full demand transparency (source: authors)

In memory of the originator of the IOBPCS family, Prof. Denis R. Towill, 1933-2015.

6 Conclusions and further research

This paper has outlined an extension of the APVIOBPCS archetype where two models are used in tandem to represent a CODP based scenario. By exploring the literatures of structural and dynamic modelling and reviewing the characteristics of both CD and FD processes, we developed the CODPBPCS model, which represents a generic hybrid FD/CD system, sometimes also referred to as hybrid MTS/MTO system. In the derivation of the CODPBPCS we have added a new component to supply chain dynamics analysis. The Forrester model (Forrester, 1958; Wikner et al., 1991) is for example based on three FDGBSS models in tandem. In this paper we have a new type of echelon, CDSBSS, that can be used in a supply chain context where the last stage actually is CD. It also means that servitization can be included more explicitly and that the dynamics of product-service systems can be analysed in a supply chain context, cf. Wikner (2012). It has also been indicated that there is limited feedback between the echelons and that the main impact upstream is from feedforward rather than feedback of information. Feedforward tends to be important between echelons and feedback within echelons, but more research is needed in this area. Table 8 provides an overview of the APVIOBPCS archetypes and the different key information flows of the variants, highlighting the unique contribution of the three new variants introduced here.

Model type ↓	Information used in ordering rule ↓	Target inventory	Actual WIP	Target WIP	VMI	Target order book	AINV or -AOB	AINV+	ABO+	CAPRATE	BL	Reference
IOBPCS							✓					Towill (1982)
VIOBPCS		✓					✓					Edghill (1990)
APIOBPCS			✓	✓			✓					John et al. (1994)
APVIOBPCS		✓	✓	✓			✓					Dejonckheere et al. (2003)
VMI-APIOBPCS		✓	✓	✓	✓		✓					Disney and Towill (2001)
VOBBPCS					✓	✓	✓					Wikner et al. (2007)
FDGBSS		✓	✓	✓			✓	✓	✓			This paper
CDSBSS										✓	✓	This paper
CODPBPCS		✓	✓	✓			✓	✓	✓	✓	✓	This paper

Table 8. Variants of the APVIOBPCS archetypes and our contribution (source: authors based on Wikner et al., 2007)

In particular, we have explored the dynamics of capacity and material availability in the CODPBPCS model. We highlighted different strategies for backlog, backorder and capacity management and we introduced non-linearities to represent capacity and material limitations (finite, semi-finite and infinite) to make the model more realistic. Through simulations we verified that the generic model derived is consistent with the previous systems archetype and behaves according to the expected properties of the FD and CD systems. Hence, this paper is important from an academic perspective as it extends the suite of the archetype.

From a managerial perspective, the CODPBPCS model can be used in the future to enable performance trade-off analysis and to develop ordering policies that will improve key performance indicators, such as cost efficiency and customer responsiveness. Since the actual

In memory of the originator of the IOBPCS family, Prof. Denis R. Towill, 1933-2015.

performance of the CODPBPCS system is a combination of the performance of the two supply subsystems FDGBSS and CDSBSS, the system can be designed to improve total supply chain performance and advise adequate collaborative strategies among echelons. In our model, absolute measures such as AINV and AOB can provide information about critical states (levels). In addition, relative measures relate the absolute measures to some other data and may e.g. provide info on how long the states will last. This relation between types of performance measures is based on Little's formula relating levels to time using a rate (flow measure): $\text{Time} = \text{Level}/\text{Rate}$. Four typical performance measures to be used for CODPBPCS:

- Quantity based absolute measures:
 - In FDGBSS material produced but not yet sold, and hence in the actual inventory (AINV), is the most critical state.
 - In CDSBSS the customer orders not yet delivered and hence in the actual order book (AOB) is the most critical state.
- Time based relative measures:
 - In FDGBSS the actual cover time (ACT) is the AINV in relation to demand (DRATE_{FD}).
 - In CDSBSS the actual delivery lead-time (ADT) is the AOB in relation to demand (DRATE_{CD}).

Several areas for further research can be outlined. The CODPBPCS in itself should be further investigated but in particular the six types of CODPBPCS models merit further research and an important venue is simulation to investigate the dynamic properties in response to e.g. step changes in demand and stochastic demand. In addition, the linear approximation of the models should be investigated to show if more simplified linear models can be used for some scenarios. For instance, supply chain resilience of the hybrid FD/CD system could be investigated using system dynamic outputs related to the performance of FD and CD subsystems as suggested by Spiegler et al. (2012). Also coverage of hybrid FD and CD could be investigated in light of the suggested model and the resource based customer order decoupling zone (Wikner, 2014). In addition, the model can be represented in z-transform for analytical modelling purposes and also several different extensions are possible such as including additional feedback paths to handle uncertain lead times for the CD part, consideration of the AOB in the decision rule for ORATE_{CD} and more variants on how to allocate capacity to the backorders by setting a range of D from zero to one rather than having D as a 0/1 variable. Finally, it would be interesting to investigate the implications for a supply chain perspective by interconnecting several CODPBPCS models.

7 Acknowledgements

We wish to thank the guest editor and reviewers for their support and advice, particularly in enhancing the description of the conceptual models in order to aid understanding.

8 References

- Braunscheidel, M.J., Suresh, N.C., 2009. The organizational antecedents of a firm's supply chain agility for risk mitigation and response. *Journal of Operations Management* 27, 119-140.
- Cannella, S., Ciancimino, E., Marquez, A.C., 2008. Capacity constrained supply chains: A simulation study. *International Journal of Simulation and Process Modelling* 4, 139-147.

In memory of the originator of the IOBPCS family, Prof. Denis R. Towill, 1933-2015.

- Carr, S., Duenyas, I., 2000. Optimal Admission Control and Sequencing in a Make-To-Stock/Make-To-Order Production System. *Operations Research*, 48(5), 709–720.
- Choi, K., Narasimhan, R., Kim, S.W., 2012. Postponement strategy for international transfer of products in a global supply chain: A system dynamics examination. *Journal of Operations Management* 30, 167-179.
- Chopra, S., Meindl, P., 2013. *Supply Chain Management: Strategy, Planning, and Operation*, 5th ed. Pearson, Boston.
- Christopher, M., Towill, D.R., 2000. Supply chain migration from lean and functional to agile and customised. *Supply Chain Management: An International Journal* 5, 206-213.
- Coyle, R. G., 1977. *Management System Dynamics* 3th ed. John Wiley & Sons, London.
- Dejonckheere, J., Disney, S., Lambrecht, M., Towill, D.R., 2003. Measuring and avoiding the bullwhip effect: A control theoretic approach. *European Journal of Operational Research*, 147, 567–590.
- Denton B., Gupta D., Jawahir K., 2003. Managing increasing product variety at integrated steel mills. *Interfaces* 33, 41–53.
- Disney, S., Towill, D.R., 2002. A discrete transfer function model to determine the dynamic stability of vendor managed inventory supply chains. *International Journal of Production Research* 40, 179–204.
- Disney, S.M., Towill, D.R., 2003. On the bullwhip and inventory variance produced by an ordering policy. *Omega* 31, 157-167.
- Disney, S.M., Towill, D.R., Van de Velde, W., 2004. Variance amplification and the golden ratio in production and inventory control. *International Journal of Production Economics* 90, 295-309.
- Dudek, G., Stadtler, H., 2005. Negotiation-based collaborative planning between supply chains partners. *European Journal of Operational Research* 163, 668-687.
- Edghill, J., 1990. *The Application of Aggregate Industrial Dynamic Techniques to Manufacturing Systems*. PhD Thesis, University of Wales College of Cardiff.
- Fisher, M., 1997. What is the right supply chain for your product?. *Harvard Business Review* 75, 105–116.
- Forrester, J.W., 1958. Industrial dynamics: a major breakthrough for decision makers. *Harvard business review* 36, 37-66.
- Giesberts, P.M.J., van der Tang, L., 1992. Dynamics of the customer order decoupling point: impact on information systems for production control. *Production Planning & Control* 3, 300-313.
- Grünwald, H.J., Fortuin, L., 1992. Many steps towards zero inventory. *European Journal of Operational Research* 59, 359-369.
- Gunasekaran, A., Patel, C., McGaughey, R.E., 2004. A framework for supply chain performance measurement. *International Journal of Production Economics* 87, 333-347.
- Gupta D., Weerawat, W., 2006. Supplier–manufacturer coordination in capacitated two-stage supply chains. *European Journal of Operational Research* 175, 67–89.
- Gupta, D., Benjaafar, S., 2004. Make-to-order, Make-to-stock, or Delay Product Differentiation? A Common Framework for Modelling and Analysis. *IIE Transactions* 36, 529–546
- Hayes, R.H., Wheelwright, S.C., 1984. *Restoring Our Competitive Edge: Competing Through Manufacturing*. Wiley, New York.
- Hedenstierna, P., Ng A. H. C., 2011. Dynamic Implications of Customer Order Decoupling Point Positioning. *Journal of Manufacturing Technology Management* 22 (8), 1032–1042.
- Hoekstra, S., Romme, J., 1992. *Integral Logistic Structures: Developing Customer-Oriented Goods Flow*. Industrial Press, New York.

In memory of the originator of the IOBPCS family, Prof. Denis R. Towill, 1933-2015.

- Hosoda, T., Naim, M. M., Disney, S. M. and Potter, A., 2008. Is there a benefit to sharing market sales information? Linking theory and practice. *Computers & Industrial Engineering*, 54 (2), 315-326
- John, S., Naim, M.M., Towill, D.R., 1994. Dynamic analysis of a WIP compensated decision support system. *International Journal of Manufacturing System Design* 1, 283-297.
- Kalantari M., Rabbani M., Ebadian M., 2011. A decision support system for order acceptance/rejection in hybrid MTS/ MTO production systems. *Applied Mathematical Modelling* 35(3), 1363–1377.
- Kaminsky, P., Kaya, N., 2009. Combined Make-to-Order/Make-to-Stock Supply Chains. *IIE Transactions*, 41, 103–119.
- Kerckanen, A., 2007. Determining semi-finished products to be stocked when changing the MTS–MTO policy: case of a steel mill. *International Journal of Production Economics*, 108, 111–118.
- Köber J., Heinecke G., 2012. Hybrid production strategy between make-to-order and make-to-stock – a case study at a manufacturer of agricultural machinery with volatile and seasonal demand. *Procedia CIRP* 3, 453–458.
- Lee, L.H., Tang, C.S., 1997. Modelling the costs and benefits of delayed product differentiation. *Management Science*, 43 (1), 40–54.
- Mason-Jones, R., Towill, D.R., 1999. Using the information decoupling point to improve supply chain performance. *International Journal of Logistics Management* 10, 13-26.
- Naylor, B., J., Naim, M., M., Berry, D., 1999. Leagility: Integrating the lean and agile manufacturing paradigms in the total supply chain. *International Journal of Production Economics* 62, 107-118.
- Olhager, J., Selldin, E., Wikner, J., 2006. Decoupling the value chain. *International Journal of Value Chain Management* 1, 19-32.
- Perona M., Sacconi N., Zanoni S., 2009. Combining make-to-order and make-to-stock inventory policies: an empirical application to a manufacturing SME. *Production Planning & Control* 20(7), 559–575.
- Potter, A., Towill, D.R., Christopher, M., 2015. Evolution of the migratory supply chain model. *Supply Chain Management: An International Journal* 20, 603-612.
- Rajagopalan, S., 2002. Make to order or make to stock: Model and Application. *Management Science*, 48(2), 241-256.
- Renna, P., 2015. Production control policies for a multistage serial system under MTO-MTS production environment. *The International Journal of Advanced Manufacturing Technology*, 83, 449-459.
- Sampson, S.E., Froehle, C.M., 2006. Foundations and implications of a proposed unified services theory. *Production and Operations Management* 15, 329-343.
- Sarimveis, H., Patrinos, P., Tarantilis, C. D. and Kiranoudis, C. T., 2008. Dynamic modeling and control of supply chain systems: A review. *Computers & Operations Research* 35(11), 3530-3561.
- Sargent, R. G., 2013. Verification and validation of simulation models. *Journal of Simulation*, 7, 12-24.
- Serwer, A., 2002. Dell does domination. *Fortune Magazine* 145(2), 70–75.
- Sharda B., Akiya N., 2012. Selecting make-to-stock and postponement policies for different products in a chemical plant: a case study using discrete event simulation. *International Journal of Production Economics* 136(1), 161-171.
- Shingō, S., 1989. *A study of the Toyota production system from an industrial engineering viewpoint* (rev. ed.). Cambridge, MA: Productivity Press.
- Shukla, V., Naim, M.M., Yaseen, E.A., 2009. ‘Bullwhip’ and ‘backlash’ in supply pipelines. *International Journal of Production Research* 47, 6477-6497.

In memory of the originator of the IOBPCS family, Prof. Denis R. Towill, 1933-2015.

- Soman C. A., van Donk D. P., Gaalman G., 2004. Combined make-to-order and make-to-stock in a food production system. *International Journal of Production Economics* 90, 223–235
- Soman, C. A., van Donk, D. P., Gaalman, G. J. C., 2007. Capacitated planning and scheduling of combined make-to-order and make-to-stock production in the food industry: an illustrative case study. *International Journal of Production Economics*, 108 (1–2), 191–199.
- Spiegler, V.L., Naim, M.M., 2014. The impact of freight transport capacity limitations on supply chain dynamics. *International Journal of Logistics Research and Applications* 17, 64-88.
- Spiegler, V.L., Naim, M.M., Wikner, J., 2012. A control engineering approach to the assessment of supply chain resilience. *International Journal of Production Research* 50, 6162-6187.
- Spiegler, V. L. M., Potter, A. T., Naim, M. M., & Towill, D. R. 2016. The value of nonlinear control theory in investigating the underlying dynamics and resilience of a grocery supply chain. *International Journal of Production Research*, 54(1), 265-286.
- Sterman, J. D. 1984. “Appropriate Summary Statistics for Evaluating the Historical Fit of System Dynamics Models.” *Dynamica* 10, 51–66
- Sun, X.Y., Ji, P., Sun, L.Y., Wang, Y.L., 2008. Positioning multiple decoupling points in a supply network, *International Journal of Production Economics*, 113(2), 943-956.
- Towill, D.R., 1982. Dynamic analysis of an inventory and order based production control system. *International Journal of Production Research* 20, 671-687.
- van Donk, D. P., 2001. Make to stock or make to order: the decoupling point in the food processing industries. *International Journal of Production Economics*, 69 (3), 297–306.
- van Donk, D.P., van Doorne, R., 2015. The impact of the customer order decoupling point on type and level of supply chain integration. *International Journal of Production Research*, 1-13.
- Wikner, J., 2003. Continuous-time dynamic modelling of variable lead-times. *International Journal of Production Research* 41, 2787-2798.
- Wikner, J., 2012. A service decoupling point framework for logistics, manufacturing, and service operations. *International Journal of Services Sciences* 4, 330-357.
- Wikner, J., 2014. On decoupling points and decoupling zones. *Production & Manufacturing Research* 2, 167-215.
- Wikner, J., Bäckstrand, J., 2011. Aligning operations strategy and purchasing strategy, EurOMA Conference, Cambridge UK.
- Wikner, J., Naim, M., Rudberg, M., 2007. Exploiting the Order Book for Mass Customized Manufacturing Control Systems With Capacity Limitations. *IEEE Transactions on Engineering Management*, 54 (1), 145-155.
- Wikner, J., Towill, D.R., Naim, M., 1991. Smoothing supply chain dynamics. *International Journal of Production Economics* 22, 231-248.
- Yáñez, F. C, Frayret, J. M., Léger, F and Rousseau, A., 2009. Agent-based simulation and analysis of demand-driven production strategies in the timber industry. *International Journal of Production Research* 47, (22), 6295-6319.
- Yang Biao, Burns D. Neil and Backhouse J. Chris, 2004. Postponement: a review and an integrated framework, *International Journal of Operations & Production Management*, 24(5), 468-487.

Appendix A. Nomenclature

Abbreviations

ACT	Actual cover time
ADT	Actual delivery lead-time
ATO	Assemble to order
CD	Customer order driven
CODP	Customer order decoupling point
CODZ	Customer order decoupling zone
DIDP	Demand information decoupling point
FC	Finite capacity
FD	Forecast driven
FM	Finite material
IC	Infinite capacity
IDP	Information decoupling point
IM	Infinite material
MRI	Minimum reasonable inventory
MTO	Make to order
MTS	Make to stock
SFC	Semi-finite capacity

Model Descriptors

APIOBPCS	Automated Pipeline, Inventory and Order Based Production Control System
APVIOBPCS	Automated Pipeline, Variable Inventory and Order Based Production Control System
CDSBSS	Customer order driven service based supply system
COBPCS	Capacity and Order Based Production Control System
CODPBPCS	CODP based production control system
FDGBSS	Forecast driven and goods based supply system
IOBPCS	Inventory and order based production control system
VOBBPCS	Variable Order Book Based Production Control System

Variables

ABO_+	Positive actual backorders
AINV	Actual inventory
$AINV_+$	Positive actual inventory
AOB	Actual order book
AVCON	Average consumption
AWIP	Actual work in process
BL	Backlog
$BORATE_{FD}$	Backorder rate in the forecast driven subsystem
CAPRATE	Capacity rate
COMRATE	Completion rate
$COMRATE_{CD}$	Completion rate in the customer order driven subsystem
$COMRATE_{FD}$	Completion rate in the forecast driven subsystem
CONS	Consumption
DINV	Desired inventory
$DRATE_{CD}$	Demand rate in the customer order driven subsystem

In memory of the originator of the IOBPCS family, Prof. Denis R. Towill, 1933-2015.

$DRATE_{FD}$	Demand rate in the forecast driven subsystem
DWIP	Desired work in process
$OBRATE_{CD}$	Order book rate in the customer order driven subsystem
ORATE	Order rate
$ORATE_{CD}$	Order rate in the customer order driven subsystem
$ORATE_{FD}$	Order rate in the forecast driven subsystem
REQRATE	Requirement rate
WIP	Work in process

Parameters

K_{INV}	Constant multiplier to determine desired inventory
K_{WIP}	Constant multiplier to determine desired WIP
CAPCON	Capacity constraint
T_A	Time to smooth consumption
T_{BO}	Time to recover backorder
T_C	Time to smooth capacity
T_I	Time to recover inventory
T_{PCD}	Lead-time in the customer order driven subsystem
T_{PFD}	Lead-time in the forecast driven subsystem
T_W	Time to recover work in process

Functions

A	Function for backorder management
a	Smoothing constant for AVCON
B	Function to determine information about actual inventory
b	Smoothing constant for $COMRATE_{FD}$
C	Function for capacity management
c	Smoothing constant for CAPRATE
D	Function for backlog management

Appendix B. System parameter setting for the simulation

CDSBSS	
T_C	2
$c = 1/(1+T_C)$	33.33%
T_{PCD}	2
T_{BO}	4
CAPCON	∞
D	0/1
FDGBSS	
T_A	8
$a = 1/(1+T_A)$	11%
T_{PFD} [weeks]	4
$b = 1/(1+T_{PFD})$	20%
T_I	4
T_W	8
K_{INV}	2
K_{WIP}	4
B	0/1

Difference equations for the simulation

CDSBSS
$REQRATE(t) = DRATE_{CD}(t) + (1-D) \times BL_{ADJ}(t-1)$
$CAP(t) = c \times REQRATE(t) + (1-c) \times CAP(t-1)$
$CAPRATE(t) = \text{Min}[CAP(t); CAPCON; REQRATE(t)]$
$BL(t) = BL(t-1) + REQRATE(t) - CAPRATE(t) - BL_{ADJ}(t-1)$
$BL_{ADJ}(t) = BL(t)/T_{BO}$
$BORATE_{FD}(t) = (ABO_+(t) - ABO_+(t-1)) / (T(t) - T(t-1))$
$ORATE_{CD}(t) = CAPRATE(t) + D \times BL_{ADJ}(t) - BORATE_{FD}(t)$
$COMRATE_{CD}(t) = ORATE_{CD}(t - T_{PCD})$
$OBRATE_{CD}(t) = DRATE_{CD}(t) - COMRATE_{CD}(t)$
$AOB(t) = AOB(t-1) + OBRATE_{CD}(t)$
FDGBSS
$DRATE_{FD}(t) = CAPRATE(t) + D \times BL_{ADJ}(t)$
$AVCON(t) = a \times DRATE_{CD}(t) + (1-a) \times AVCON(t-1)$ Full demand transparency
$AVCON(t) = a \times DRATE_{FD}(t) + (1-a) \times AVCON(t-1)$ Limited demand transparency
$AINV(t) = AINV(t-1) + COMRATE_{FD}(t) - DRATE_{FD}(t)$
$ABO_+(t) = -\text{min}(0, AINV(t))$
$AINV_+(t) = AINV(t) + ABO_+(t) \times B$
$DINV(t) = AVCON(t) \times K_{INV}$
$EINV(t) = T_I \times (DINV(t) - AINV_+(t))$
$AWIP(t) = AWIP(t-1) + ORATE_{FD}(t) - COMRATE_{FD}(t)$
$DWIP(t) = AVCON(t) \times K_{WIP}$
$EWIP(t)/T_W = (DWIP(t) - AWIP(t))/T_W$
$ORATE_{FD}(t) = AVCON(t) + EINV(t-1) + EWIP(t-1)$
$COMRATE_{FD}(t) = b \times ORATE_{FD}(t) + (1-b) \times COMRATE_{FD}(t-1)$